

Light Water Reactor Sustainability Program

Development and Evaluation of the Conceptual Design for a Liquid Radiological Waste System in an Advanced Hybrid Control Room



August 2018

U.S. Department of Energy

Office of Nuclear Energy



DISCLAIMER

This information was prepared as an account of work sponsored by an agency of the U.S. Government. Neither the U.S. Government nor any agency thereof, nor any of their employees, makes any warranty, expressed or implied, or assumes any legal liability or responsibility for the accuracy, completeness, or usefulness, of any information, apparatus, product, or process disclosed, or represents that its use would not infringe privately owned rights. References herein to any specific commercial product, process, or service by trade name, trade mark, manufacturer, or otherwise, does not necessarily constitute or imply its endorsement, recommendation, or favoring by the U.S. Government or any agency thereof. The views and opinions of authors expressed herein do not necessarily state or reflect those of the U.S. Government or any agency thereof.

Development and Evaluation of the Conceptual Design for a Liquid Radiological Waste System in an Advanced Hybrid Control Room

**Casey Kovesdi
Zachary Spielman
Rachael Hill
Katya Le Blanc
Johanna Oxstrand**

August 201

**Prepared for the
U.S. Department of Energy
Office of Nuclear Energy**

ABSTRACT

This research is a part of the United States (U.S.) Department of Energy-sponsored Light Water Reactor Sustainability (LWRS) Program conducted by Idaho National Laboratory in close collaboration with representatives of the nuclear industry. The joint goal is to provide the technical foundations for licensing and managing the long-term, safe, and economical operation of current nuclear power plants (NPPs). Because NPPs maintain outdated or obsolete equipment, it is common practice to replace worn-out equipment on an as-needed basis. This results in a series of like-for-like replacements of components on the control boards that address only the immediate need to replace equipment. Such upgrades rarely represent an encompassing or systematic vision for control room modernization and do not add the benefit of enhanced support for operators in the control room, missing the opportunity to reduce operation and maintenance costs through enhanced efficiency. The purpose of the research described in this report is to provide guidance on how to realize these opportunities by designing control room human-system interfaces (HSIs) with advanced capabilities in mind. Further, this work seeks to ensure that control room modernizations are undertaken with a sound understanding of the impacts to human operators and are designed based on state-of-the-art human factors principles. The goal of the research is to provide an industry-wide approach and road map for effective modernization that not only addresses obsolescence but provides guidance for enhancing the economic viability of the existing fleet. This can be done by improving efficiency and safety through effective design of the control room, incorporating human factors principles across the entire design. This report describes the conceptual design of the liquid radiological waste system and reports on several research activities that inform the design philosophy. Finally, this document presents recommended updates to the original design philosophy based on those findings.

ACKNOWLEDGEMENTS

We are grateful for the ongoing support, expertise, and championing of this work from the radiological waste control room contacts—Lorenzo Slay, Mark McKinley, William Gardner, and John Hernandez—of Arizona Public Services. We would also like to thank Micheal Hildebrandt, Robert McDonald, and Jens-Patrick Langstrand at the Institute of Energy Technology who were integral to the experimental design for the operator workshop by providing technical expertise and support with the micro-task data collection activities. Additionally, we would like to thank Jacob Lehmer, Maira Orozco, Tyson Hansen, and Brandon Rice of INL for their support in designing the prototypes, assistance in the study design, and help with implementation of prototypes. This report was made possible through funding by the United States Department of Energy Light Water Reactor Sustainability Program. Lastly, we would like to thank Alison Hahn of the Department of Energy and Ken Thomas, Craig Primer, and Bruce Hallbert of Idaho National Laboratory for championing this effort.

CONTENTS

| | |
|--|-----|
| ABSTRACT..... | iii |
| ACKNOWLEDGEMENTS..... | v |
| ACRONYMS..... | xii |
| 1. INTRODUCTION..... | 1 |
| 1.1 Hybrid Control Room..... | 1 |
| 1.2 Radiological Waste Control Room..... | 2 |
| 1.3 Review of design concepts..... | 3 |
| 1.3.1 Ecological Interface Design..... | 3 |
| 1.3.2 Information-Rich Display..... | 3 |
| 1.3.3 Function-Oriented Displays..... | 4 |
| 1.3.4 Task-Based Displays..... | 4 |
| 1.3.5 High Performance HMI..... | 4 |
| 2. RESEARCH ACTIVITIES..... | 6 |
| 2.1 Graphical User Interface Development and Evaluations..... | 6 |
| 2.2 2017 Operator Workshop..... | 7 |
| 2.2.1 Micro-Task Study: Evaluation of Color for Components and Process Flow..... | 7 |
| 2.2.2 Dynamic Scenario..... | 13 |
| 2.3 Ergonomic Study..... | 20 |
| 2.3.1 Summary of the Ergonomics Study..... | 20 |
| 2.3.2 Method..... | 21 |
| 2.3.3 Results..... | 27 |
| 2.4 Functional allocation analysis..... | 32 |
| 2.4.1 Operational Sequence Diagram..... | 32 |
| 2.5 NUREG-0711 Crosswalk..... | 34 |
| 2.5.1 Purpose..... | 34 |
| 2.5.2 Method..... | 34 |
| 2.5.3 Outcome..... | 35 |
| 2.6 2018 March Operator Workshop..... | 37 |
| 2.6.1 Soft Control Evaluation..... | 37 |
| 2.6.2 Design input interview..... | 48 |
| 2.6.3 Method..... | 49 |
| 2.6.4 Results..... | 50 |
| 2.7 2018 July Workshop..... | 53 |
| 2.7.1 Evaluation of Color to Determine Component Status at a Distance..... | 53 |
| 2.7.2 Legibility Study..... | 60 |
| 2.7.3 Soft Control Preference Follow-Up Study..... | 66 |
| 2.7.4 Ergonomics Evaluation for Reach Requirements..... | 71 |
| 3. DESIGN PHILOSOPHY..... | 78 |
| 3.1 General Design Philosophy..... | 78 |
| 3.2 Ensuring an Effective End-state in a Phased Approach..... | 79 |
| 3.3 Information Architecture..... | 79 |

| | | |
|--------|---------------------------|-----|
| 3.3.1 | Design Philosophy | 79 |
| 3.3.2 | Technical basis | 79 |
| 3.4 | Overviews | 81 |
| 3.4.1 | Design Philosophy | 81 |
| 3.4.2 | Technical basis | 82 |
| 3.5 | Use of Mimics | 84 |
| 3.5.1 | Design Philosophy | 84 |
| 3.5.2 | Technical basis | 84 |
| 3.6 | Use of Color | 86 |
| 3.6.1 | Design Philosophy | 86 |
| 3.6.2 | Technical basis | 86 |
| 3.7 | HSI Navigation | 88 |
| 3.7.1 | Design Philosophy | 88 |
| 3.7.2 | Technical basis | 89 |
| 3.8 | Controls | 90 |
| 3.8.1 | Design Philosophy | 90 |
| 3.8.2 | Technical basis | 91 |
| 3.9 | Integrated Displays | 97 |
| 3.9.1 | Design Philosophy | 97 |
| 3.9.2 | Technical basis | 97 |
| 3.10 | Use of Graphics | 99 |
| 3.10.1 | Design Philosophy | 99 |
| 3.10.2 | Technical basis | 100 |
| 3.11 | Alarms | 104 |
| 3.11.1 | Design Philosophy | 104 |
| 3.11.2 | Technical basis | 104 |
| 4. | CONCLUSIONS | 107 |
| 5. | REFERENCES | 108 |
| 6. | APPENDICES | 110 |

FIGURES

| | |
|---|----|
| Figure 1. Three-dimensional (3-D) model of an existing radiological control room..... | 2 |
| Figure 2. Example of mini trend plots in an IRD..... | 4 |
| Figure 3. Evaporator system overview with embedded control..... | 7 |
| Figure 4. Factorial representation of independent variables of interest. | 9 |
| Figure 5. Trial design for the evaluation of color for components and process flow. | 10 |
| Figure 6. Interactive computerized procedure used in the dynamic scenario. | 13 |
| Figure 7. Interview questions for the dynamic scenario post-task session. | 16 |
| Figure 8. Example micro trend operators expected to be clickable. | 17 |
| Figure 9. Example level indication with blue highlighted halo that operators expected to be clickable..... | 17 |
| Figure 10. Current control room “green band indication.” | 18 |
| Figure 11. HSI indication showing ‘0’ but perceptually appearing at ‘5.’ | 19 |
| Figure 12. The actual radiological waste control room..... | 21 |
| Figure 13. 3-D model of workstation in existing radiological waste control room. | 22 |
| Figure 14. 3-D model of the workstation of existing radiological waste control room. | 22 |
| Figure 15. 3-D model of the LRS panel and gaseous and solid radiological waste panel in existing radiological waste control room. | 23 |
| Figure 16. 3-D model of the evaporator panel and BAC panel in existing radiological waste control room. | 23 |
| Figure 17. Planned changes to the evaporator panel and BAC panel. | 24 |
| Figure 18. Planned changes to LRS panel and gaseous and solid radiological waste. | 24 |
| Figure 19. Ariel view of the modified radiological waste control room footprint. Red outline indicates equipment that has been removed. | 25 |
| Figure 20. Ergonomic qualities for a prospective workstation/desk..... | 28 |
| Figure 21. Leg clearance considerations..... | 29 |
| Figure 22. Visual field of operator (horizontal line of sight) considerations..... | 30 |
| Figure 23. Visual field of operator (straight-ahead line of sight) considerations. | 30 |
| Figure 24. Workplace (i.e., control room configuration) considerations. | 31 |
| Figure 25. Sample of the operational sequence diagram to support functional allocation and task analysis. | 33 |
| Figure 26. Sample of NUREG-0711 Crosswalk..... | 35 |
| Figure 27. Depiction of HFE elements completed per Figure 1-1 of NUREG-0711..... | 36 |
| Figure 28. Soft control design schemes evaluated..... | 37 |
| Figure 29. Soft control evaluation data collection process. | 40 |
| Figure 30. Colocated versus Designated Faceplate: Total cursor movement comparison..... | 43 |

| | |
|--|----|
| Figure 31. NASA-RTLX responses between colocated versus designated faceplate designs..... | 45 |
| Figure 32. Illustrated soft control schemes for preference evaluation. | 45 |
| Figure 33. Most preferred response characteristics..... | 46 |
| Figure 34. Least preferred response characteristics. | 46 |
| Figure 35. Importance rating of minimizing occlusion, cursor movement, and eye movement. | 47 |
| Figure 36. HSI display concepts used in the micro-task evaluation of color from a distance. | 53 |
| Figure 37. Task flow for the micro-task evaluation of color from a distance..... | 55 |
| Figure 38. Task 1 response time results for the micro-task evaluation of color from a distance..... | 56 |
| Figure 39. Task 2 response time results for the micro-task evaluation of color from a distance..... | 57 |
| Figure 40. Task 3 response time results for the micro-task evaluation of color from a distance..... | 57 |
| Figure 41. Task 4 response time results for the micro-task evaluation of color from a distance..... | 57 |
| Figure 42. Workload results for Tasks 1-4 for the micro-task evaluation of color from a distance. | 58 |
| Figure 43. Perceived task difficulty for Tasks 1-4 for the micro-task evaluation of color from a distance. | 59 |
| Figure 44. Task instructions for the legibility study. | 61 |
| Figure 45. Raw response time distributions for Task 1. | 63 |
| Figure 46. Geometric means of response times for Task 1..... | 63 |
| Figure 47. Raw response time distributions for Task 2. | 64 |
| Figure 48. Geometric means of response times for Task 2..... | 64 |
| Figure 49. Preference responses for legibility study..... | 65 |
| Figure 50. Interview facilitator working with an operator in soft control preference study. | 67 |
| Figure 51. Operator working with a soft control scheme in the soft control preference study. | 67 |
| Figure 52. Most and least preferred soft control design schemes from main control room operators. | 68 |
| Figure 53. Use of highlighting multiple components tied to a single controller..... | 69 |
| Figure 54. Delta E 2000 values for the radiological waste control room HSI display color palette..... | 70 |
| Figure 55. Luminance contrast values for the radiological waste control room HSI display color palette..... | 70 |
| Figure 56. Control board console used for the anthropometric reach model. | 71 |
| Figure 57. 3-D model snippet used to support the ergonomics interview..... | 74 |
| Figure 58. Reach envelopes for the 5 th Percentile Female and 95 th Percentile Male. | 75 |
| Figure 59. Estimated proportion of female and male operators unable to reach furthest HSI control using functional reach. | 76 |
| Figure 60. Typical automation system hierarchy..... | 80 |
| Figure 61. Control operation stereotypes for U.S. population. Adopted from NUREG-0700 Figure 3.1. | 93 |

Figure 62. Display formats for representative tasks. Adopted from NUREG-0700 Rev. 2 Table 1.1. 100

TABLES

| | |
|--|-----|
| Table 1. Representative Questions per Sub-Block..... | 9 |
| Table 2. Relation of Eye Tracking Measures to Human Factors Constructs | 10 |
| Table 3. Representative Questions per Sub-Block..... | 12 |
| Table 4. Descriptive Statistics for NASA-RTLX | 15 |
| Table 5. Descriptive Statistics for SART and SEQ..... | 15 |
| Table 6. Descriptive Statistics for the Usability Questionnaire | 15 |
| Table 7. Ergonomic workstation/desk and chair selection checklist. | 20 |
| Table 8. HFE design guidelines. | 26 |
| Table 9. Soft Control Tradeoffs. | 39 |
| Table 10. Soft Control Block Design..... | 40 |
| Table 11. Description of Selected Measures for the Soft Control Evaluation. | 41 |
| Table 12. Summary Results of Soft Control Evaluation..... | 42 |
| Table 13. Operator Opinions: Potential for Error Prone Situation Due to Design of Soft Control Schemes. | 47 |
| Table 14. Summary of Responses for Design Input Interview. | 50 |
| Table 15. Comparison of Anthropometric Data for Functional Reach from Selected HFE Resources..... | 72 |
| Table 16. Comparison of Anthropometric Data for Shoulder Height from Selected HFE Resources..... | 72 |
| Table 18. HFE Design Guidance for Use of Color | 86 |
| Table 19. Common Associated Meanings of Select Colors Used in the Nuclear Industry..... | 87 |
| Table 20. Operator Displays | 88 |
| Table 22. Key Guidelines from NUREG-0700 Specific to the Design of the Soft Control Systems | 94 |
| Table 23. Key HFE Guidance for Integrated Displays | 97 |
| Table 24. Key HFE Guidance for Use of Graphics | 101 |

ACRONYMS

| | |
|-----------|---|
| 3-D | three-dimensional |
| BAC | boric acid concentrator |
| CPP | critical performance parameter |
| CVCS | Chemical Volume Control System |
| DCS | Distributed Control System |
| EC | engineering control |
| EID | ecological interface design |
| EPRI | Electric Power Research Institute |
| FC | fixation count |
| FD | fixation duration |
| FOD | function-oriented display |
| HFE | human factors engineering |
| HMI | human-machine interface |
| HPHMI | high performance human-machine interface |
| HSI | human-system interface |
| HSSL | Human System Simulation Laboratory |
| I&C | instrumentation and controls |
| IA | information architecture |
| ID | identification number |
| INL | Idaho National Laboratory |
| IRD | information-rich display |
| IV | independent variable |
| LRS | liquid radiological waste system |
| LWRS | Light Water Reactor Sustainability |
| MA | minutes of arc |
| MLM | multi-level model |
| NASA-RTLX | National Aeronautics and Space Administration Raw Task Load Index |
| NPP | nuclear power plant |
| NRC | Nuclear Regulatory Commission |
| OSD | operational sequence diagram |
| PI | plant information |
| PVGS | Palo Verde Generating Station |
| RT | response time |

| | |
|------|--------------------------------------|
| SART | Situation Awareness Rating Technique |
| SEQ | Single Ease Questionnaire |
| SRO | senior reactor operator |
| TBD | task-based display |
| TCS | Turbine Control System |
| TTFF | time to first fixation |
| TTLF | time to last fixation |
| VDU | visual display unit |

Development and Evaluation of the Conceptual Design for a Liquid Radiological Waste System in an Advanced Hybrid Control Room

1. INTRODUCTION

1.1 Hybrid Control Room

This research is a part of the United States (U.S.) Department of Energy-sponsored Light Water Reactor Sustainability (LWRS) Program conducted at Idaho National Laboratory. The LWRS Program is performed in close collaboration with industry research and development programs and provides the technical foundations for licensing and managing the long-term, safe, and economical operation of current nuclear power plants (NPPs). One of the primary missions of the LWRS Program is to help the U.S. nuclear industry adopt new technologies and engineering solutions that facilitate the continued safe operation of NPPs and to identify way to enhance the economics of NPPs by reducing operation and maintenance costs.

One challenge facing the U.S. nuclear industry is maintaining outdated or obsolete equipment. Many NPPs are choosing to replace worn out equipment on an as-needed basis. This approach results in a series of like-for-like replacements of components on the control boards that address only the immediate need to replace equipment that is past its usable life. Such upgrades rarely represent an encompassing or systematic vision for control room modernization. They may leave control rooms in a hybrid digital and analog state with inconsistently designed upgraded systems. Further, these upgrades do not add the benefit of enhanced support for operators in the control room, missing the opportunity to reduce operation and maintenance costs through enhanced efficiency.

Although there are significant challenges in undertaking control room modernization, there are also significant opportunities to enhance the efficiency and reliability by carefully designing the upgraded systems to support operators and to include advanced features such as diagnostic support, advanced human-system interface (HSI) designs, and decision support tools. The purpose of this report is to provide guidance on how to realize those opportunities by designing control room HSIs with these advanced capabilities in mind. Further, this work seeks to ensure that control room modernizations are undertaken with a sound understanding of the impacts to human operators and are designed based on state-of-the-art human factors principles.

This research is conducted in close collaboration with a utility partner undergoing a phased modernization approach. The first phase of the project is updating a local control room for the liquid radiological waste system, and additional phases will result in modernizing about 60 percent of the main control room's equipment. The purpose of this research is to provide an industry-wide approach and road map for effective modernization that not only addresses obsolescence but provides guidance for enhancing the economic viability of the existing LWR fleet. This can be done by improving efficiency and safety through effective design of the control room, incorporating human factors principles across the entire design. The approach addresses human factors throughout the entire upgrade process by first identifying a realistic and desirable end-state concept for the control room layout, then by identifying how to ensure consistency throughout the upgrade process with an overarching design philosophy, and finally by providing guidance on how to enhance the effectiveness of upgraded HSIs. The final step is accomplished by considering the end state throughout the life of the phased upgrade project and incorporating an integrated approach to HSI design in each system upgrade, regardless of the individual components being upgraded. Previous work has defined an end-state vision for the control room layout. The work identified which components would be removed in each phase of the upgrade and where new digital displays would be located on the control boards (Boring et al., 2016). A second phase of this

research identified an initial end-state design philosophy for the new digital displays (Le Blanc et al., 2018).

This report describes the conceptual design of Phase 1, the liquid radiological waste system, and reports on several research activities that inform the design philosophy. Finally, this document presents recommended updates to the original design philosophy based on those findings.

1.2 Radiological Waste Control Room

The main purpose of a radiological waste control room is to capture, store, and repurpose radiological waste. The typical forms of radiological waste are solid, gas, or liquid form. One of the most common uses of the radiological waste control room is to repurpose liquid radiological waste. Through evaporation, both pure water and concentrated boric acid, which are essential for the operation of the plant, can be reclaimed. The actions performed to operate the radiological waste system, such as opening a locally operated valve in the plant, take place either in the local control room or out in the plant. A radiological waste control room may have two rows of large cabinets with controls and indicators (e.g., knobs, buttons, and meters), as illustrated in Figure 1.



Figure 1. Three-dimensional (3-D) model of an existing radiological control room.

The INL research effort studied the liquid radiological waste evaporator and the BAC, both of which are subsystems of the liquid radiological waste system (LRS). At the collaborating utility, there is only a handful radiological waste operators. Usually, one to two operators are stationed in the control room a couple of times per year. The BAC is exercised three to four times per 18-month refueling cycle, and the evaporator is used three times per year, on average. It takes about four hours to start up the evaporator and about 1.5 hours to start up the BAC, if every component works as intended. The evaporator's function is to remove water from and increase concentration of total solids in liquid waste. The function of the BAC is to process borated primary wastes from the chemical volume and control system holdup tank. The evaporator and the BAC perform the same functions but for different purposes. Both systems evaporate water from the radiological waste; however, the evaporator reclaims and repurposes the clean water while

the BAC system reclaims and repurposes the boric acid. Since these systems are so similar, the evaporator can be used as a backup to the BAC system if the BAC becomes unavailable. In the spirit of plant modernization and control room upgrades, it is envisioned that the systems and cabinets in the radiological control room will be replaced with a digital control system operated via a new digital HSI on workstation monitors. The researchers developed and evaluated design concepts for the graphical user interface for the evaporator and the BAC system. The design concepts and their technical bases are described in this report.

1.3 Review of design concepts

The first step in this research was to develop a cohesive design philosophy that would apply to all phases of the modernization project. Several existing approaches and philosophies for HSI design were considered by the research team when developing the design philosophy. These approaches are briefly summarized in the next section.

1.3.1 Ecological Interface Design

Ecological interface design (EID) is a work-domain approach to designing complex social-technical system interfaces. The EID approach is centered on two principle activities: (1) determine the information requirements based on models of the work domain, usually accomplished through an abstraction hierarchy which is paired with a part-whole decomposition of the systems; and (2) represent that information in ways that consider the strengths and limitations of human cognitive ability. EID highlights the importance of supporting skill and rule-based behavior more than knowledge-based behavior (Rasmussen et al., 1994). Thus, displays are designed to facilitate the use of signals and signs which yield well-practiced straightforward responses and minimize the reliance on symbols which rely on operator knowledge and decision making to perform tasks. The advantage of the EID approach over traditional approaches, such as task analysis, is it leads to interface designs that can facilitate operator decision making in unanticipated or abnormal events (Lau et al., 2008).

In simulated control room studies, displays designed using the EID approach have been shown to aid operator performance for unanticipated or abnormal events in process control (Vicente, 2002), medicine (Vicente, 2002), and nuclear power plant control rooms (Lau et al., 2008). The advantage of EID approach is the flexibility its resilience in abnormal situations however, depending upon the implementation, operators may have to modify their mental model of the nuclear process. For example, operators may have to think of the plant in terms of energy balance (Braseth et al., 2009). Careful regard of this trade-off is important to the end design state.

1.3.2 Information-Rich Display

Information-rich displays (IRD) are characterized by several principles that allow large amounts of information to be displayed in ways that facilitate situational awareness. IRD is currently implemented in large screen overview displays however, the principles may be implemented on smaller screen displays as well. One of the main features of IRD is the use of the “Dull Screen principle” (Braseth et al., 2009). The Dull Screen principle is characterized by the conservative use of saturated color, which is reserved for important signals like alarms. The static elements of the display are presented in shades of grey to minimize interference with the important and dynamic elements of the display. Another important principle in IRD is the use of analog display elements. Careful design of analog displays can reduce the amount of cognitive effort (i.e., memorizing and calculating) necessary when compared with simply displaying a digital value. One of the major examples of utilizing analog display elements is the use of normalized, integrated mini trends. Mini-trend plots are integrated into the configurable displays instead of digital values. On the mini trend plot, the scale is normalized so the top is the high-high alarm set point and the bottom is the low-low alarm set point. The center (on the y axis) of the plot is the normal operating value. The region between the low and low-low alarm set points is shaded with a low contrast color (the same is true for the high and high-high alarm set points). These plots are grouped so that the set

of plots is perceived as a single object and that deviation in a single parameter is easily detected (i.e., see Figure 2 for an example).

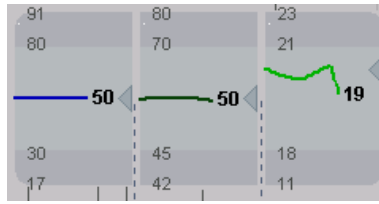

Figure 2. Example of mini trend plots in an IRD.

1.3.3 Function-Oriented Displays

Function-oriented display (FOD) design is based on a functional analysis. As part of this approach, the analyst determines high level goals and then decomposes the plant into functions and sub-functions and these are then represented explicitly on the HSI display. In 2005, an evaluation of a function-oriented display indicated that operators liked the high-level overview and felt that the FOD was a good way to organize the process information (Braseth et al., 2009).

1.3.4 Task-Based Displays

The task-based approach is to design displays that provide operators with all information needed to perform pre-defined tasks as effectively and safely as possible. The display design caters to the task-relevant system information and interdependencies needed to perform effectively within a pre-defined task space. Initial work indicated that procedure-based tasks were particularly suited for such an approach. At the Institute of Energy Technology in Norway, work in the HAMMLAB (a modern control center that can be used as a test-bed design), in support of task-based displays (TBDs) determined three types of displays were useful to support the task-based display concept. These are the Procedure Selection and Overview Display, the Procedure Performance Display, and the Event-dependent Assistance. Results indicated 60 percent of operators preferred computerized procedures, and a subset indicated that the TBD concept is necessary for operations in a computerized control room.

1.3.5 High Performance HMI

High performance human-machine interface (HPHMI) are displays depicting relevant information which in context is made useful to the operator (Hollifield et al., 2008). A HPHMI should be designed to provide process values along with the context of what is expected or desired. This will enable the operator to scan and process multiple values on the display within a few seconds and hence improve the operator's ability to detect abnormalities early.

The use of color according to the HPHMI concept includes:

- Using a gray background and muted colors minimize screen glare and reflection,
- Using the dull screen concept to make abnormal and alarm conditions more salient,
- Using bright colors to draw attention to abnormal conditions,
- Indicating alarms by a redundantly coded (e.g., shape, color, and text) element depicting the presence and priority of the alarm,
- Using colors alone should not be the only discriminator of an important status condition,
- Using colors for alarm conditions should also not be used for less important information,
- Using brightness coding and words to indicate component state (e.g., use white color and the word "RUNNING" to indicate a pump is operating).

The HPHMI describes the use of a four-level graphic hierarchy based on progressive exposure of detail:

- Level 1 – Process area overview. ‘The big picture overview.’
- Level 2 – Process unit display. The primary graphic for detailed surveillance and control manipulations. These displays should have embedded trends with indications of the desirable range.
- Level 3 – Process unit detail display. Addresses a single piece of equipment of control scheme. To be used for detailed diagnosis.
- Level 4 – Process diagnostic display. Provides details of subsystems, individual sensors, or components.

2. RESEARCH ACTIVITIES

This section summarizes the research activities completed for fiscal years 2017 and 2018. Section 2.1 describes the initial design concepts for the evaporator system. Section 2.2 and its sub-sections describe evaluation activities that facilitated the redesign of the evaporator, the design philosophy for the Liquid rad-waste system, and control room modernization.

2.1 Graphical User Interface Development and Evaluations

To facilitate development of HSI design concepts and evaluate those designs, the team developed an overall display philosophy for the systems in the radiological waste control room for the operator workstation concept. The concept includes system overview displays with embedded control for the evaporator and the boric acid concentrator. A third display will contain overview information for the rest of the liquid radiological waste system. The fourth display will contain alarm information. Each display will be presented on one of the four monitors in the control room.

Le Blanc et al., (2014) describes several features that are commonly found in overview displays. The team selected the characteristics that were incorporated into the radiological waste control room overview displays based on the benefits proposed and the constraints and opportunities provided by the radiological waste control room system itself.

The systems contained in the radiological waste control room are relatively simple compared to the overall plant systems. Further, even after the planned upgrades, many of the components will be operated locally. Therefore, it is possible to represent the portions of the system that will be operated from the control room on a single overview display. This allowed for the available task-related information and the relevant system information to be displayed on a single display.

The design of the overview display features a simplified mimic of the entire evaporator system with all of the remotely operated equipment represented. The data for the system is embedded within the system in mini-trends and micro-trends. The mini-trends present data for the controllers (i.e., flow and level controllers in the system) and contain alarm set point information as well as trending of the control parameters. The set points are also represented on the mini-trend. All other system parameters are shown on micro-trends, which show the digital value of the parameter at its current level and a brief historical trend of the parameter.

Control is embedded on the overview display. The operator must simply click on a component (e.g., valve or pump) to bring up the associated controller faceplate. The faceplates pop up in a dedicated portion of the screen on the bottom-right side. The components of an active control faceplate are highlighted with a blue halo. The operator can click on a small button to the right of the mini-trend to bring up the controller. Clicking on any of the components associated with controller will also bring up the controller (i.e., clicking on a level valve will bring up the level controller).

The researchers adopted a semi-dull screen approach to color. The majority of the static elements in the screen are presented in shades of gray. Dynamic data is presented in a standard green used for live data (reference design standard), and active components are highlighted in white (they are gray when closed or off). The only static portions of the screen that are colored are the different flow paths for the product streams, and these are presented in muted colors. Dynamic information such as highlighting the selected components or the status of components is presented in a bright blue. Alarm states are presented in a saturated red. Figure 3 shows the overview and illustrates the concepts discussed above.

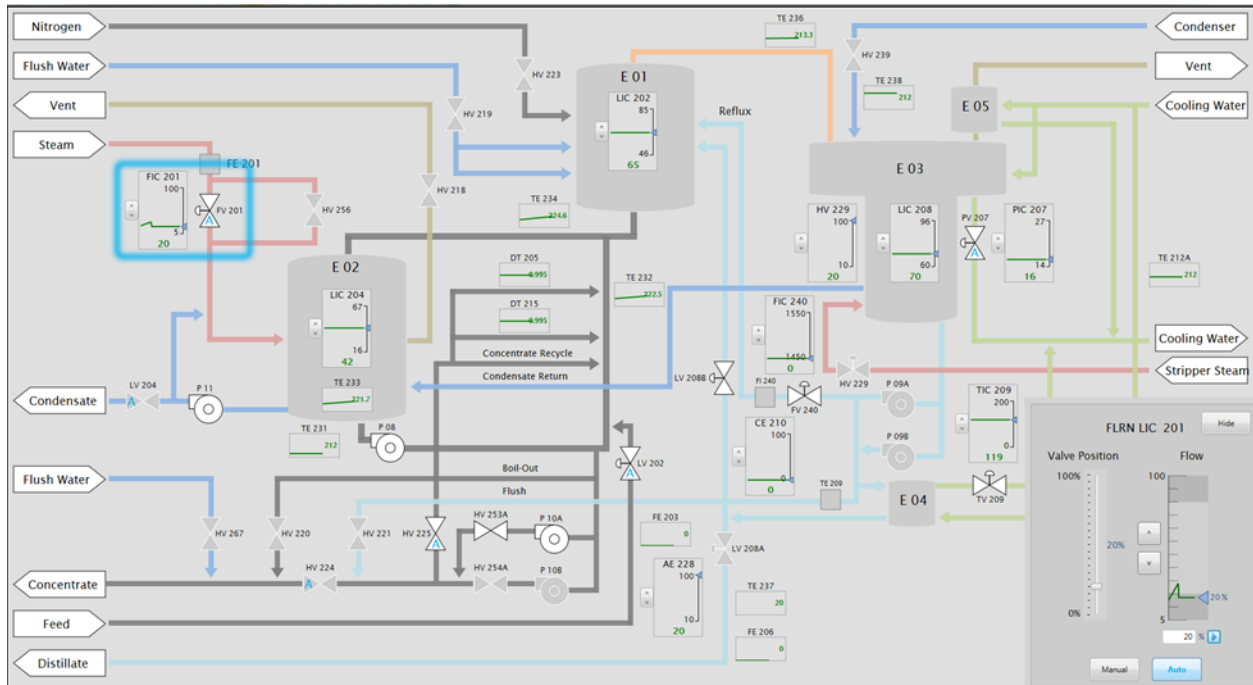

Figure 3. Evaporator system overview with embedded control.

2.2 2017 Operator Workshop

A design evaluation was conducted at Palo Verde Generating Station (PVGS) in August 2017. The workshop involved operators experienced with operating the LRS and experienced field operators, which have not operated the LRS but are familiar with its purpose. The workshop contained two parts:

1. A systematic comparison of color schemes to identify operator performance using traditional color conventions compared to the dull-screen concept.
2. A dynamic start up scenario to elicit operator feedback on interacting with the system during a typical operation.

2.2.1 Micro-Task Study: Evaluation of Color for Components and Process Flow

2.2.1.1 Purpose

Although several design approaches suggest using a dull screen, typical nuclear power plant interfaces utilize saturated red and green to identify component status. For example, most commercial NPPs use red to indicate that a valve is open or a pump is on, and green to denote that a valve is closed or a pump is off. When prototypes that utilize a dull screen are presented to operators, they tend to show a strong preference for their red green conventions. This study was designed to determine if there are any observable performance differences based on color scheme to support design decisions relating to color scheme across the moderation effort.

The micro-task experiments provided objective performance data to inform design decisions for the use of color for various HSI design elements such as valve and pump status, and the use of color to visually differentiate different process streams. The micro-task experiments provided a technical basis for

the design philosophy on use of color through various trade-off evaluations^a. This study sought answers to the following research questions:

1. What effect do the various color schemes have on detection performance (e.g., Do red/green component indications help operators determine component state faster or more accurately than white/grey)? See also Section 2.7.1.
2. Do color coded product streams improve operator’s ability to identify consequences of system configuration more accurately or more quickly? See also Section 2.6.2.
3. Do red/green valve and pump indications help operators more quickly determine how a system is aligned?
4. Does the dull screen help the operator detect alarm/off normal state more quickly?
5. What are the interactions between the different color use strategies (i.e., do color coded product streams reduce the effect of red/green valves or the salience of alarms)?

This activity supported design decisions from the questions above through the use of focused tasks pertaining to: (1) finding embedded alarms; (2) finding and determining valve status; and (3) using colored coded process paths to find related system components.

2.2.1.2 Candidate HSI Design Concepts

There were four different design concepts under evaluation. These included:

1. Dull Screen (white grey and muted blue only), active components were highlighted in white.
2. Dull screen with muted colors representing different product streams/flow paths.
3. Dull Screen with bright component status color (red/green stereotype), but no other color.
4. Dull Screen with bright component status color (red/green stereotype), but muted colors representing different product streams/flow paths.

The combination of design concepts can be conceptualized in the following 2x2 matrix.

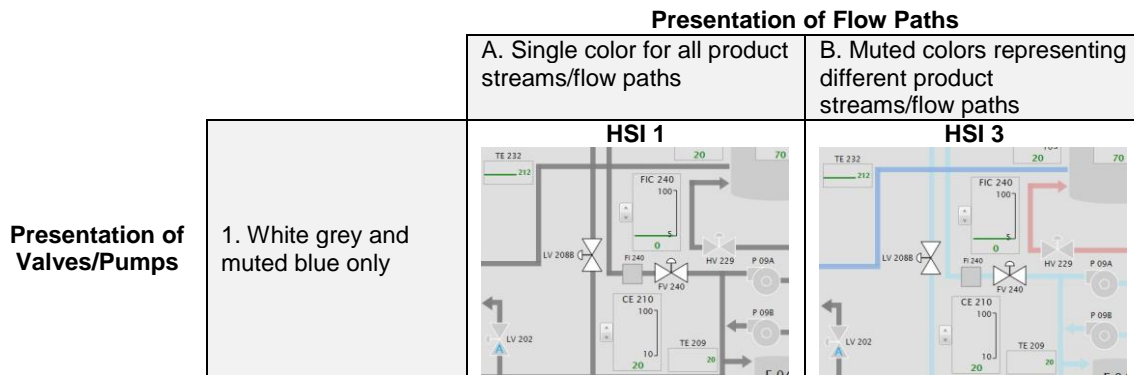

^a Per NUREG-0711 Section 8.4.6, a trade-off evaluation is defined as “comparisons between design options, based on aspects of human performance that are important to successful task performance, and to other design considerations.”

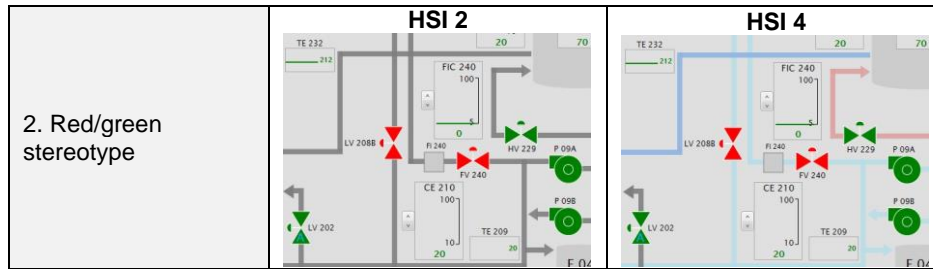

Figure 4. Factorial representation of independent variables of interest.

2.2.1.3 Method

2.2.1.3.1 Experimental Software Platform

To answer these higher-level questions, four focused experiments (i.e., micro-tasks) were created using an experimental program developed by the Institute of Energy Technology as a framework. The program displays static images as visual stimuli and reads in the location and name of areas of interest (AOI) from extensible markup language data files. The AOIs were created as a square shapes centered on the provided location. Using the location of the user’s gaze provided by the eye tracking technology and the given AOIs, the program recorded the frequency and duration that the AOIs were viewed. The order in which the AOIs were looked at was also recorded by the program as well as response times and accuracy from key presses.

2.2.1.3.2 Experimental Protocol and Design

Each of the four HSI designs represented its own experimental block, which were presented to participants in a random fashion and were counterbalanced across participants to control for order effects. Within each HSI block, there were a total of three question set blocks (i.e., Block 1, Block 2, and Block 3); these question blocks contained multiple trials. The question set blocks were sequentially provided (e.g., Block 1 > Block 2 > Block 3) while individual questions within each block were randomly assigned without replacement. Each question block became progressively more complex. Block 1 contained an ‘A’ and ‘B’ sub-block. Block 2 also contained an ‘A’ and ‘B’ sub-block. Block 3 did not contain any sub-blocks. An embedded alarm task was presented in all three question-set blocks. The rationale for embedding the alarm detection experiment as a secondary task was to provide additional realism. Therefore, it was assumed that having alarms embedded as a secondary task would be a more valid assessment of the efficacy of the alarm’s visual salience qualities versus merely instructing participants to find the alarm on the display. Table 1 provides a summary of the experimental protocol.

Table 1. Representative questions per sub-block.

| Block | Sub-Block | Question Type | Number of Trials |
|-------|-----------|--|------------------|
| 1 | A | “What is the position of [valve X]?” | 10; 3 alarms |
| | B | “What is the status of [pump X]?” | 4; 1 alarm |
| 2 | A | “What system is [component X] associated with?” | 7; 3 alarms |
| | B | “What would be the effect of changing the component status on the temperature in [tank y] by [opening/closing] [component X]?” | 5; 2 alarms |
| 3 | N/A | “With the system in the current configuration what would be the result on level of [tank y] if we [open/close] [valve X]?” | 7; 2 |

Responses were binary where participants responded using either the ‘z’ or ‘/’ keys to answer each question. Participants responded to alarms by pressing ‘space’ rather than answering the question.

Response times and accuracy were collected from these key presses. Eye tracking was also used to collect visual search behavior.

Each question set block contained a brief familiarization period to which the participant was instructed to press each key (e.g., ‘z, /, space’) to map to its corresponding response for the question (e.g., ‘open, close, alarm’). Each question set block contained a similar workflow where a question was presented in the top center of the screen until the participant read and acknowledged the question by pressing ‘enter.’ Next, a brief mask was presented with a crosshair in the center of the screen for 1000 milliseconds (ms). The purpose of the fixation screen was to ensure the participants’ initial gaze was in a consistent location prior to starting each trial. Finally, a stimulus image was presented along with the question in the top center of the screen. Participants were instructed to answer as quickly and accurately as possible, and to prioritize finding alarms over answering the question. Figure 5 illustrates this workflow.

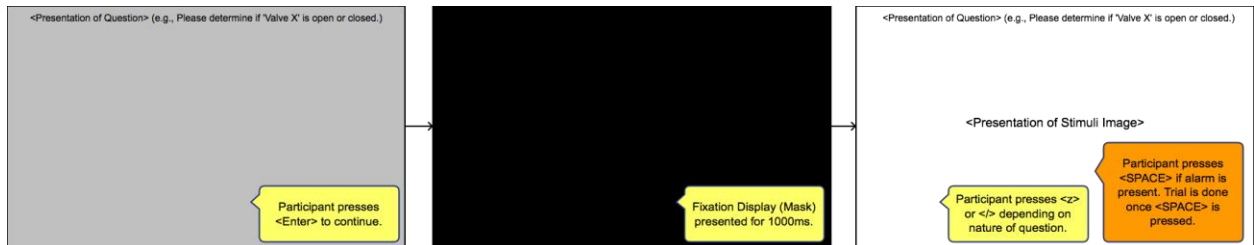

Figure 5. Trial design for the evaluation of color for components and process flow.

2.2.1.4 Performance Measures

Performance measures included response time (RT), accuracy, fixation count (FC), fixation duration (FD), time to first fixation (TTFF), time to last fixation (TTLF), and latency between TTLF to correct RT (LTLFTR). *RT* was defined as the total time elapsed from the trial onset to the time the participant responded. *FC* was defined as the frequency of fixations (i.e., temporal and spatial pauses in eye movements where information processing occurs) during a trial. *FD* was defined as the average fixation duration (ms) for a given trial. TTFF was defined as the time difference between the trial on-set to the time of the first fixation that landed on the target AOI (e.g., the information needed to answer the question). TTLF was defined as the time difference between the trial on-set to the time of the landed fixation that landed on the target AOI (e.g., the information needed to answer the question). TTLF was used to calculate LTLFTR. LTLFTR was defined as the time difference between TTLF to the RT. These measures are described in greater detail in INL/EXT-15-37311 Rev. 0, which discuss the relation of each measure to important human factors constructs such as visual attention, scan/search efficiency, and mental workload. Table 2 summarizes the relation of selected eye tracking measures from the micro-tasks to key constructs.

Table 2. Relation of eye tracking measures to human factors constructs.

| Construct | Eye Tracking Measure | Correlation to Construct |
|------------------------|--|--------------------------|
| Scan/Search Efficiency | Fixation Count (FC) | (-) |
| | Time to First Fixation (TTFF) | (-) |
| Mental Workload | Fixation Duration (FD) | (+) |
| | Latency Between TTLF between RT (LTLFTR) | (+) |

2.2.1.5 Analysis Description

A multi-level model (MLM) was created for each of the performance measures and question set block. One motivation for using the MLM was its ability to handle dependent data (i.e., by participant). Likewise, MLM is more robust in handling instances of homogeneity of regression slopes, assumptions of independence, and missing data, which would otherwise violate assumptions common to traditional

general linear models like analysis of variance (Field et al., 2012). Each MLM model specified independent variables (IVs) *HSI Order*, *Component Color*, *Flow Stream Color* and *Component Flow Stream Color* as random effects, being nested within participant. Likewise, each MLM model sequentially introduced independent variables in a sequential order to systematically test the statistical contribution of each IV. Post hoc tests were run on each IV that yielded statistical significance using Tukey Honest Significant Difference post hoc tests. All MLM models were run in R.



2.2.1.6 Participants

A total of twelve operators ($n = 12$) consented to participate in the experiment. Of these, two operators had to leave midway through resulting in a total of ten operators with usable response time data. Of these ten operators, the eye tracker malfunctioned midway through the experiment for two additional operators resulting in a total of eight operators who yielded usable eye tracking data. Several operators had over five years of experience and the most experienced had over 30 years. It should be noted that this sample included the entire LRS operator population. Four operators were trained to operate the LRS system (which comprises the entire population of operators who are fully trained to operate the LRS system), but other operators had some experience with the LRS system.

2.2.1.7 Result Summary

The following table summarizes the key findings from each of the micro-task question set blocks. A detailed discussion of these results can be found in the report “Evaluation of Control Room Interface Designs to Support Modernization in Nuclear Power Plants” (Le Blanc et al., 2017). Table 3 shows the representative questions for each sub-block.

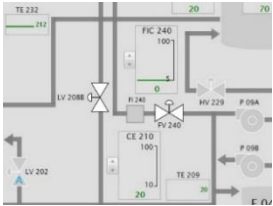
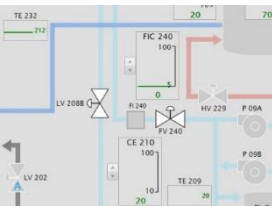
Table 3. Representative questions per sub-block.

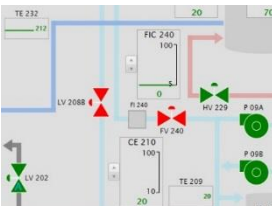
| | | Flow Path color | | |
|------------------------|--------------------------------|---|--|--|
| | | Single color for all product streams/flow paths | Muted colors representing different product streams/flow paths | Component color Results |
| Component color | White gray and muted blue only |  <p>✓ Best Alarm detection performance</p> |  <p>✓ Fastest response time a for identifying system alignment and consequences</p> <p>✓ Most efficient visual search time for identifying system alignment and consequences</p> | <p>✓ Most efficient “comprehension time”</p> |
| | Red/green stereotype |  |  | <p>✓ Fastest response times and better search efficiency for identifying component state</p> <p>× Lowest Accuracy when identifying component state</p> |

2.2.2 Dynamic Scenario

Operators complete a dynamic scenarios using a dynamic prototype that replicate the system responses during and evaporator start up scenario. This helped operators to evaluate the design as it would be experienced in a real-life scenario. The start up scenario was selected to demonstrate the functionality of the dynamic prototype because it is a common operation. A portion of the start up procedure that maximized the amount of equipment and monitoring that happens in the control room, and minimizes activities that must be carried out elsewhere in the plant, was selected to for the start up scenario.

2.2.2.1 Computer Based Procedure

Operators completed the start up scenario using an interactive computerized procedure. Operators then provided feedback of their experience with the computerized procedure.

The screenshot shows the 'Evaporator Startup Instructions' interface. It features a 'Note' section with a warning about venting, followed by a 'Caution' section regarding steam flow limits. The main content consists of a list of steps, each with a checkbox and a 'Mark Auto' button. The steps include: 1. Did the SM/CRS direct to maintain less than 20% total steam flow or less than 60% total steam flow? (20%); 6.6.44. Adjust LRN-FIC-201, Heating Element Steam Flow Indicator Controller, to slowly raise steam flow by no more than 1600 lbm/hour (5% dial indication) every three minutes while maintaining less than 20% total steam flow as indicated on LRN-FIC-201. (Adjusted); 6.6.46. Do conditions permit automatic control? (Yes); 6.6.46*. Place LRN-FIC-201, Heating Element Steam Flow Indicator Controller, in auto. (Mark Auto); 6.6.47. Does LRN-LIC-208, Distillate Level Indicator Controller, indicate 70% (65-75%)?; 6.6.47*. Wait until Distillate Level Indicator Controller, indicates 70% (65-75%); 6.6.47*. Perform the following: Place one of the following in the AUTO position to start a distillate pump: -LRN-P09A, -LRN-P09B; Place LRN-LIC-208, Distillate Level Indicator Controller, in the AUTO position.; 6.6.48. Place LRN-HS-256, Steam Bypass Valve, in the AUTO position.; 6.6.49. Ensure LRN-FI-240, Evaporator Vapor Body Reflux Flow, is adjusted to maintain 1500 lbm/hour reflux flow. A 'Caution' section is at the bottom. A bottom navigation bar contains icons for Summary, Instructions, and References.

Figure 6. Interactive computerized procedure used in the dynamic scenario.

2.2.2.2 Objectives

The dynamic scenario served as a method to collect further information on the HSI design in a dynamic context, specifically:

1. Gain quantitative measures on the performance of the system in relation to the operator and vice versa.

2. Gain qualitative measures and feedback on additional information regarding HSI considerations.
3. Identify overlooked errors or newly introduced human error traps within the design.
4. Gain a sense of how applicable the demonstrated design was to other systems outside LRS.

The information gained after operator engagement with a dynamic design implementation was incorporated into the technical basis for the overall design philosophy. Achieving the listed objectives confirmed design decisions made up to this point while exposing design assumptions previously overlooked or under researched.

2.2.2.3 Method

The dynamic scenario was presented to all of the participants attending the workshop hosted by the collaborating utility in August 2017. The interactive mimic was used as the platform for operators to engage with the proposed HSI and provide feedback on the various characteristics presented.

Operators were asked to participate in the dynamic start up scenario after they had completed the micro-task study. They were provided familiarization through a self-driven Microsoft Power Point presentation which explained how to operate the system. The researcher remained continually available to answer questions or provide further explanation of specific concepts throughout the training. As part of the dynamic scenario, the operators were asked to use a computerized procedure instead of the traditional paper procedure. Hence, the operators were also briefed on the main differences between standard paper-based process and the computerized procedure.

The operators were asked to talk aloud during their experience with the dynamic scenarios and provide any feedback or comments as it came to them rather than waiting until the end to discuss. Once the briefing was complete, the operator confirmed their readiness to begin, then the dynamic scenario was placed into manual control. Throughout the scenario, the researcher and operator kept an open dialogue driven by the operator's observations as they completed the procedure steps.

2.2.2.4 Dynamic Scenario Protocol

Operators were seated at a workstation and asked to review a familiarization presentation. The operators completed the presentation at their own pace, asking questions as needed. A tablet displaying the computerized procedure was given to the operator following the training. The computerized procedure contained an overview of the initial conditions and expected operations, before beginning the procedure, much like a shift turnover summary. After reading and acknowledging the summary, the operators navigated to the procedure and the simulation was placed in manual control.

During the procedure operators provided feedback as they handled different situations. If hesitation or confusion occurred, the researcher prompted the operator to express what was causing the difficulty in the scenario. After completing the dynamic scenario, operators were asked to fill out the National Aeronautics and Space Administration Raw Task Load Index (NASA-RTLX), Situation Awareness Rating Technique (SART), a Usability Questionnaire, and a Single Ease Questionnaire (SEQ). Further discussion and free form operator feedback followed the questionnaires.

2.2.2.5 Questionnaire Results

Operators filled out four different questionnaires after the dynamic scenario: NASA-RTLX, SART, SEQ, and a usability questionnaire. NASA-RTLX and SART are both rated from one to ten (low to high), SEQ is rated from one to seven (very difficult to very easy) and the usability questionnaire is rated from one to five (strongly disagree, disagree, neither agree nor disagree, agree, strongly agree). The results from these questionnaires are summarized in the tables below. Descriptive statistics include mean (*M*) and standard deviations (*SD*). See Table 4 and

Table 5. Situation Awareness in

Table 5 is calculated from:

$$\text{Situation Awareness} = [\text{Understanding} - (\text{Demand} - \text{Supply})]$$

Table 4. Descriptive Statistics for NASA-RTLX.

| | Mental | Physical | Time | Performance | Effort | Frustration | TLX |
|-------------|--------|----------|-------|-------------|--------|-------------|------|
| Mean | 5 | 1.125 | 2.125 | 1.5 | 3.875 | 2.375 | 3.83 |
| SD | 1.69 | 0.35 | 1.55 | 1.07 | 1.73 | 2.07 | 0.65 |
| | | | | | | | |

Table 5. Descriptive Statistics for SART and SEQ.

| | Understanding | Demand | Supply | Situation Awareness | SEQ |
|-------------|---------------|--------|--------|---------------------|------|
| Mean | 12.78 | 9.00 | 29.44 | 33.22 | 5.78 |
| SD | 4.52 | 3.87 | 5.98 | 6.48 | 1.20 |

In general, the greatest perceived workload expressed from operators by NASA-RTLX was mental workload, followed by frustration. All other workload indices were relatively low, with physical being lowest. Perceived situation awareness was rated relatively high as shown with relatively high understanding of the situation and supply of attentional resources compared to demands of attentional resources. SEQ was relatively high indicating the operators perceived the scenario to be relatively easy. Finally, the usability questionnaire revealed that operators mostly perceived the new HSI to be usable (see Table 6). There were some negative comments as recorded from the questionnaire concerning: (1) numerical information; (2) lacking information to complete the scenario; and (3) lacking all of the functionality needed. All operators agreed that the new HSI would be more usable than the existing configuration.

Table 6. Descriptive statistics for the usability questionnaire.

| Question | Strongly disagree | Disagree | Neither agree nor disagree | Agree | Strongly Agree | N/A |
|--|-------------------|----------|----------------------------|-------|----------------|-----|
| 1. The information was organized logically on the screen. | 0 | 0 | 0 | 6 | 3 | 0 |
| 2. The information on the screen was easy to see and read. | 0 | 0 | 0 | 5 | 4 | 0 |
| 3. The information format was consistent throughout the HSI. | 0 | 0 | 0 | 6 | 3 | 0 |
| 4. The information was presented in a way that was familiar to me. | 0 | 0 | 2 | 3 | 4 | 0 |
| 5. The terminology used was familiar to me. | 0 | 0 | 0 | 7 | 2 | 0 |
| 6. Numerical information was presented in the units I normally work. | 0 | 3 | 0 | 4 | 2 | 0 |
| 7. The mimic format accurately represented the Evaporator system. | 0 | 0 | 1 | 4 | 4 | 0 |
| 8. The mimic format was appropriate for Evaporator start up. | 0 | 0 | 0 | 5 | 4 | 0 |
| 9. All of the information needed was available on the HSI to complete Evaporator start up. | 0 | 1 | 2 | 3 | 3 | 0 |
| 10. All of the functionality needed to complete the scenario was available. | 0 | 2 | 0 | 2 | 5 | 0 |
| 11. The input device (the mouse and keyboard) provided was appropriate to complete the scenario. | 0 | 0 | 0 | 3 | 6 | 0 |
| 12. Overall, the HSI was more usable than the existing system when completing Evaporator start up. | 0 | 0 | 0 | 3 | 5 | 1 |

2.2.2.6 Operator Free Form Feedback results

Operators, when inspired, provided continual feedback during the dynamic scenario, such as commenting on their preferences, errors they noticed, difficulties they are having, and improvements they appreciate. The level of feedback was largely determined by the operator and their willingness to elaborate on their comments however prepared questions as shown in Figure 7 helped stimulate conversation and critical thought towards the system design.

| |
|--|
| <p style="text-align: center;"><u>Controls</u></p> <ol style="list-style-type: none">1. Was it clear or unclear on how to access pop-up windows with [1] equipment that had trends?2. Was it clear or unclear on how to access pop-up windows with [2] equipment that were valves?3. Is the blue halo square sufficiently salient to differentiate actively selected controls from others?4. For valve controllers in MANUAL mode, what was your preferred method of adjustment? ([1] slider, [2] up/down arrows, [3] entering text into field)5. For valve controllers in AUTO mode, what was your preferred method of adjustment? ([1] slider arrow, [2] entering text into field)6. What are your thoughts on the way the concept HSI allows for adjusting valve position? Are there any concerns without having a confirmation? <p style="text-align: center;"><u>Trends</u></p> <ol style="list-style-type: none">7. Do the micro trends provide a sufficient amount of detail for you to complete your task?8. Is the trend format a preferred display format for the micro trends?9. Do the regular trends provide a sufficient amount of detail for you to complete your task? <p style="text-align: center;"><u>Flow Streams</u></p> <ol style="list-style-type: none">10. Do the colors provide any value with differentiating the different flow streams?11. Are the colors sufficiently different from each other to allow you to adequately differentiate?12. Are the colors distracting or not distracting? <p style="text-align: center;"><u>Pump and Valve States</u></p> <ol style="list-style-type: none">13. Is it clear what valves are open and what valves are closed? What cue did you use to tell? Were the colors sufficiently different?14. Is it clear what pumps are open and what valves are closed? What cue did you use to tell? Were the colors sufficiently different?15. Is it clear what valves are in manual and what valves are in auto? Was the labeling clear to you? Was it legible?16. Is it clear what pumps are in manual and what pumps are in auto? Was the labeling clear to you? Was it legible? <p style="text-align: center;"><u>Overall Mimic Display</u></p> <ol style="list-style-type: none">17. Was the mimic display at an appropriate level of detail to perform your task?18. Did the mimic display accurately represent the evaporator system? |
|--|

Figure 7. Interview questions for the dynamic scenario post-task session.

The following are conclusions based on operator's subjective feedback of the dynamic scenario. Note that operators had also completed the micro-task study minutes before beginning the dynamic scenario and had thus been exposed to all four HSI design combinations. HSI design three was used in the dynamic scenario (i.e., gray/white pumps with pastel colored flow paths). Operators often made comparisons between all design types as well as designs and color schemes from past plant experiences. The operators involved in the study were trained LRS operators as well as auxiliary operators who had some experience with the LRS system.

2.2.2.1 Pump and Valve Color

The majority of operators favored the white/gray scheme. Comments described the color scheme as easy to see, intuitive, and usable. Another operator admitted the red/green color scheme masked the embedded alarms nested in trends where the white/gray avoided this issue.

The reason behind preferences for a red/green scheme was largely traditional, although one operator preferred the red/green scheme because of the contrast it provided.

There were conflicting opinions regarding how easy a transition to a new color scheme would be. Among the participants were ex-Navy officers with experience on nuclear submarines and trained on a red/green scheme with reversed meaning compared to red/green scheme at the partner utility. Their

experience had taught them that the switch is a quick and easy transition. Others felt the transition would be similar to learning the HSI on newer systems in the plant such as the spray ponds. Overall, most operators preferred the white/gray color scheme with reservation towards potential challenges with mixed display themes throughout the plant.

2.2.2.2 Flow Path Color

Operators unanimously preferred the colored flow paths in comparison to the grey flow paths. The same operator that felt the white/gray color scheme was easy on the eyes echoed this sentiment for the colored flow-path. Another noted that the colored flow-paths helped in identifying multiple indications that a specific action was taken to confirm what they intended to happen is what took place.

2.2.2.3 Interaction Methods

The prototype design used a clickable interface using the pump and valve icons as buttons to open a control menu located in a dedicated portion of the screen. Normal trends used an up/down arrow icon next to them as depicted in Figure 8 to view the control faceplate.

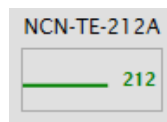

Figure 8. Example micro trend operators expected to be clickable.

A click action on a pump, valve, or normal trend button would bring up the control faceplate and highlight the component being controlled in a rectangular blue halo, as shown in Figure 9, to easily associate the control faceplate with the component or trend. Micro trends were not clickable in this version of the prototype but are intended to be interactive in the final version. Most operators asked for all information to be clickable such as the micro trends and were informed this was the intention for the final product, but not feasible to incorporate in this prototype stage.

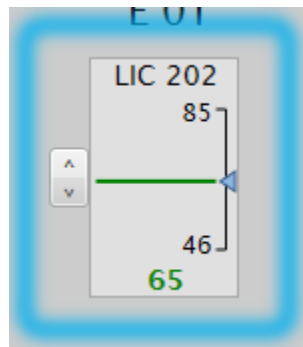

Figure 9. Example level indication with blue highlighted halo that operators expected to be clickable.

Operators commented that all clickable areas were too small. The common suggestion was to increase the clickable areas to all screen space within the halo that would appear after clicking the component. Note: for pumps and valves, this was a mild irritation for the operators, however, the up/down arrow icon on normal trends posed a significantly greater dissonance in operator action.

To operators, the up/down arrow icon appears as if clicking it would result in a system response. The appearance that an action may take place made operators nervous. Thus, operators would click everywhere on the trend before finally clicking the up/down icon. Many operators asked the researcher what to expect from the icon before clicking on it.

Operators requested the control faceplate disappear after clicking anywhere on the screen and not only after clicking the “hide” button. It was observed that nearly every operator attempted this method and was met with confusion when their method failed. Also, one operator requested the faceplate location be localized to the component valve being controlled. Others did not seem to take issue with the faceplate location though its location was not verbally supported either.

The overall faceplate design was accepted by the operators with a few design suggestions. First, the set-point established in automatic mode was removed if the component was switched to manual mode leaving the operator to reset the valve position. It appeared in this scenario context that maintaining the setting from automatic was a desired function. One operator requested that a dichotomous “open/close” button be added to the control faceplate for valves citing a preference to either reduce number or clicks or avoid a slider-style control option when possible. Another operator appreciated all the information provided by the faceplate.

2.2.2.4 Trends

Operators responded positively to the presentation of the trends. They appreciated the localization and general set up of the trends. The operator who commented that the colored flow paths were helpful in identifying “multiple indications of actions” also made the comment because the trends were located on, or in direct relation, to the flow path. A general comment was making the trends clickable. One operator was more specific asking that, by clicking an alarmed trend, the alarm information would be displayed on a separate screen.

One operator requested that the “green band” functionality be added to the trends. He was referencing the green band as seen in Figure 10 that indicates a component’s set point. The operator wanted the ability to quickly reference every component and confirm it was either “in” or “out” of its desired band. However, over time using the prototype, the operator commented the way the trends were laid out actually supported such capability noting that if the trends were “...all straight then all good.”



Figure 10. Current control room “green band indication.”

Finally, the trends confused some operators when at a “Zero” state. The trend line did not dip below the alarm set point indicating a value contradicted by a value directly below it with true component status. One operator commented that the trend should reflect the value as this could mislead the operators or delay them as they seek other means to confirm component status. Figure 11 demonstrates the concept described by the operator.

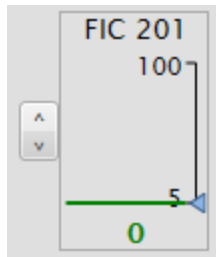

Figure 11. HSI indication showing '0' but perceptually appearing at '5.'

2.2.2.1 Labelling

A near unanimous agreement that a verbatim matching of procedure language and prototype labelling is required for any HSI design. However, note that the original procedure was applied to the prototype which naturally created some labeling discrepancies. If more resources had been available, a revised procedure would have been created to match the mimic labelling.

The mimic injected a critical difference in search strategy as well. The current control room requires operators to search for controllers while the prototype supports searching for the equipment, then opening the controllers. One operator pointed out that equipment numbers and controller numbers do not always match, though it is rare, which could cause some real confusion or error if the procedure did not reflect the mimic labelling verbatim. For this study all controllers had the same numerical tag as the controllers therefore, this issue was not realized.

It was widely preferred that noun names be used on the prototype while still preserving the equipment identification. Noun names refer to the descriptive name of the component such as 'stripper steam valve' versus 'HV 229.' Some suggested that noun names be used on the mimic while the equipment identification (both component and controller) be present on the faceplate. One operator suggested using larger labels as well.

2.2.2.2 Computerized Procedure

Operators reacted positively to computerized procedures overall. Although some specific comments were made requesting minor changes such as making 'note' and 'caution' steps more explicit and allowing backward navigation. Of the operators who provided feedback, all were in favor of the computerized procedures.

2.2.2.3 General

Operators were largely positive to the new design offering comments such as "Awesome design," "intuitive," "easy to see and is usable." It appears from operator impressions the design would be accepted and usable granted some of the specific changes requested by operators. Many operators favored the white and grey pump scheme. Some who favored the white/grey expressed concern that training others on the new system could be challenging. The primary arguments for red/green pump/valve scheme are tradition and saliency. The colored flow path scheme was met with complete acceptance. Trends were greatly appreciated with a few comments for improvement. Labelling was met with the most criticism, but operators provided helpful and specific input for improvement. Using a mimic as the design scheme seemed to allow LRS operators the ability to perform a start up procedure regardless of experience.

2.3 Ergonomic Study

This section describes the ergonomic study performed by the researchers to support the planned modifications to the layout and workstation configuration for the radiological waste control room by ensuring human factors considerations are identified and addressed.

2.3.1 Summary of the Ergonomics Study

The researchers developed a model of the radiological waste control room to provide human factors engineering (HFE) design input into the planned modifications concerning the layout and workstation configuration for the radiological waste control room. Three-dimensional models were developed to support the HSI design process as described in the U.S. Nuclear Regulatory Commission's (NRC) Human Factors Engineering Program Review Model (NUREG-0711, Rev. 3). Specifically, the 3-D models were developed and used to: (1) aid in visualizing the planned modifications of the control room to better support discussion with the collaborating utility of potential enhancements; and (2) support in providing early design guidance to the new control room that reflect state-of-the-art HFE design principles as described in NUREG-0711 Section 1.2.1.

Results from this evaluation comprised a generalizable ergonomics checklist (see Table 7) that can be used when selecting the new workstation for sit/stand operations. This checklist can be used to support the selection of a workstation/desk and chair that conforms to the state-of-the-art HFE design principles as described in the NRC Human-System Interface Design Review Guidelines (NUREG-0700, Rev. 2). The next sections describe the detailed methods and results from this activity.

Table 7. Ergonomic workstation/desk and chair selection checklist.

| Ergonomic Workstation/Desk and Chair Selection Checklist | | |
|---|------------------------------|-----------------------------|
| This checklist is intended to be used to assist in the selection of a workstation/ desk and chair that conform to NRC's NUREG-0700, Rev. 2, "Human-System Interface Design Review Guidelines" (2002), which are currently regarded as state-of-the-art human factors engineering design principles per NUREG-711. | | |
| If 'NO' is marked on any one question regarding the workstation/desk or chair, then the model does not conform to NUREG-0700. | | |
| Workstation/ Desk Selection | | |
| 5. Does the workstation/desk provide sit/stand capability? | <input type="checkbox"/> YES | <input type="checkbox"/> NO |
| 6. Does the workstation/desk support at least four 24-inch monitors? | <input type="checkbox"/> YES | <input type="checkbox"/> NO |
| 7. Does the workstation/desk have a separate adjustable monitor board? | <input type="checkbox"/> YES | <input type="checkbox"/> NO |
| 8. Is the width of the desk less than 78 inches (i.e., to allow for adequate room clearance)? | <input type="checkbox"/> YES | <input type="checkbox"/> NO |
| 9. Verify that the following dimensions are met: | <input type="checkbox"/> YES | <input type="checkbox"/> NO |
| <ul style="list-style-type: none"> • Work surface is at least 16 inches deep • Work surface is at least 24 inches wide (preferably > 30-inches) • Work surface is approximately 25 inches from the floor (for adequate knee room) • Knee room depth is at least 18 inches • Knee room width is at least 20 inches | | |
| Chair Selection | | |
| 10. Does the chair provide wheels to allow it to move? | <input type="checkbox"/> YES | <input type="checkbox"/> NO |
| 11. Does the chair have a backrest for lumbar support? Note, a recommended angle between the back and the seat is 100 degrees. | <input type="checkbox"/> YES | <input type="checkbox"/> NO |
| 12. Does the chair have adjustable or retractable armrests? | <input type="checkbox"/> YES | <input type="checkbox"/> NO |
| 13. Does the chair have cushioning for the seat and backrest? | <input type="checkbox"/> YES | <input type="checkbox"/> NO |
| 14. Is the chair seat at least 18 inches wide? | <input type="checkbox"/> YES | <input type="checkbox"/> NO |

| Ergonomic Workstation/Desk and Chair Selection Checklist | | |
|---|------------------------------|-----------------------------|
| 15. Is the chair seat depth between 15 inches and 17 inches deep? | <input type="checkbox"/> YES | <input type="checkbox"/> NO |
| 16. Is the chair seat adjustable for seating height? | <input type="checkbox"/> YES | <input type="checkbox"/> NO |

2.3.2 Method

The researchers developed the models using feedback from collaborating utility and measurements of the current radiological waste control room collected through field visits involving observations and walk downs of the actual control room. These activities involved observing and interviewing plant personnel, as well as taking measurements and photographs of the control room and panels to develop 3-D models of the existing control room configuration and the modified configuration including the planned upgrades. Engineering control (EC) drawings were also used as part of developing the overall layout of the 3-D model of the control room models to ensure that they were dimensionally correct.

The 3-D models were developed using the Trimble SketchUp software package. Photographs of the control boards were used as surface textures helping depict both the physical arrangement of the room and control panel organization. The photograph supported a surface texture quality to view detailed devices on the boards. To minimize clutter in the model, non-essential objects (e.g., lighting fixtures, ceilings, and other items that did not have an impact to interactions with the control systems) were excluded. The next two subsections provide 3-D model illustrations of the existing and modified version of the radiological waste control room.

2.3.2.1 Existing Control Room

Figure 1 shows an image taken of the existing radiological waste control room. This image can be used to compare the existing control room rendering in the 3-D model shown in Figure 13 through Figure 16.



Figure 12. The actual radiological waste control room.



Figure 13. 3-D model of workstation in existing radiological waste control room.



Figure 14. 3-D model of the workstation of existing radiological waste control room.



Figure 15. 3-D model of the LRS panel and gaseous and solid radiological waste panel in existing radiological waste control room.



Figure 16. 3-D model of the evaporator panel and BAC panel in existing radiological waste control room.

2.3.2.2 Modifications to the Radiological Waste Control Room

The following modifications to the radiological waste control room were documented based on the field visits and continuing communication with the collaborating utility:

- The evaporator panel, boric acid concentrator, and LRS are to be removed from the control room.
- The interface components of the instrumentation and controls (I&C) from these panels are to be migrated onto a single workstation displayed from a digital HSI system. Likewise, three cabinets that house the electronics/controls of the I&C will replace the existing panels.
- The existing workstation is to be removed and replaced with a new workstation.

These modifications to the radiological waste control room are illustrated in Figure 17 through **Error! Reference source not found.19.**

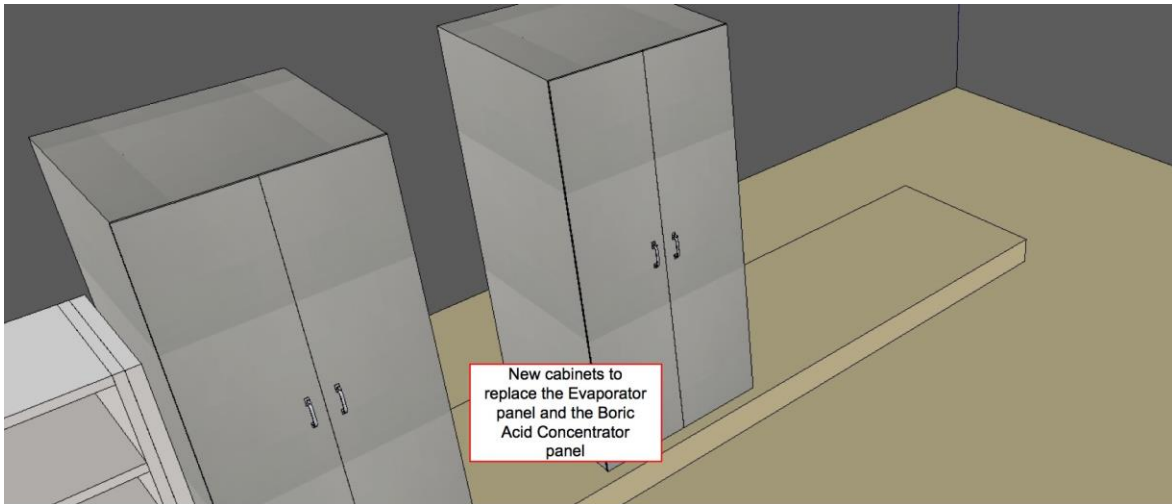

Figure 17. Planned changes to the evaporator panel and BAC panel.

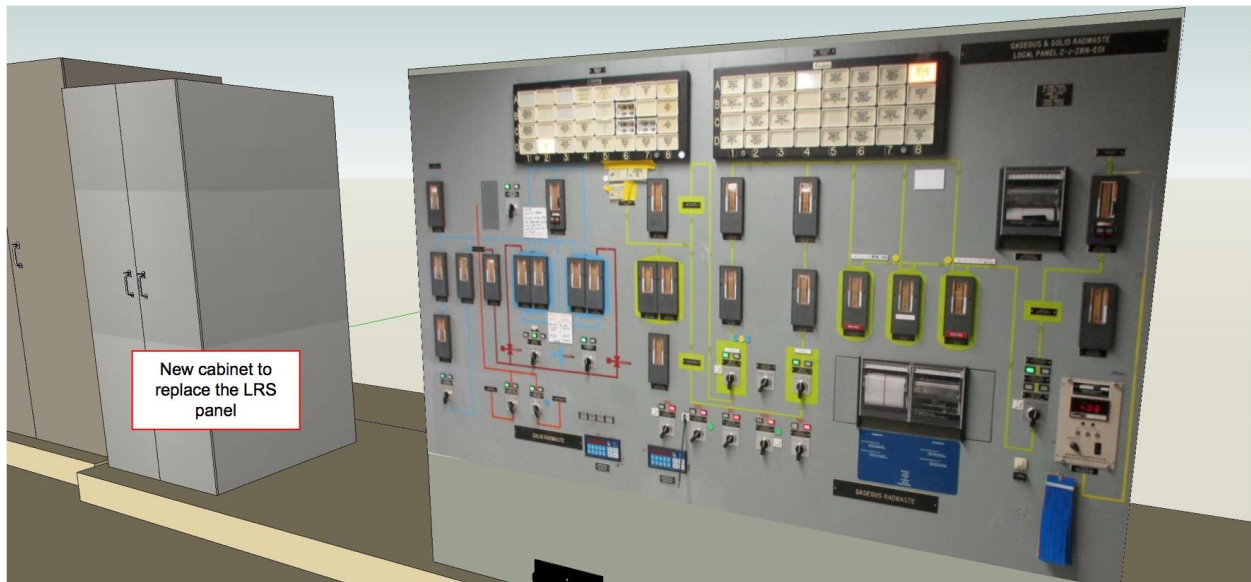

Figure 18. Planned changes to LRS panel and gaseous and solid radiological waste.

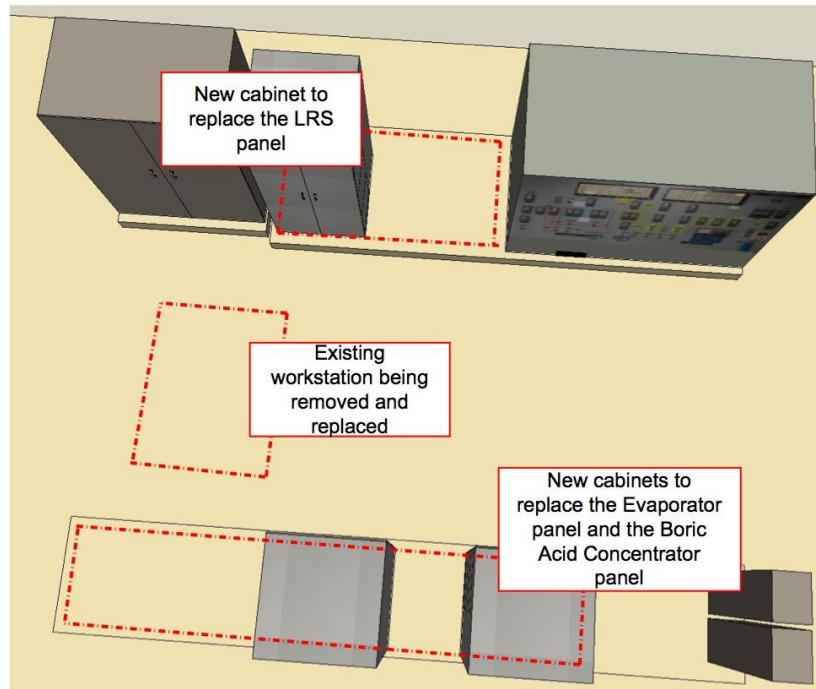

Figure 19. Ariel view of the modified radiological waste control room footprint. Red outline indicates equipment that has been removed.

2.3.2.3 Existing Control Room

This evaluation used applicable state-of-the-art HFE design principles from the EPRI “Human Factors Guidance for Control Room and Digital Human-System Interface Design and Modification” (EPRI TR-3002004310) and NRC’s NUREG-0700, Rev. 2, “Human-System Interface Design Review Guidelines” (2002) to support HFE design suggestions. The design suggestions from this evaluation also accounted for other considerations obtained from the interviews, observations, and walk-throughs. Collectively, these considerations can be summarized as follows:

Cabinet locations: The locations for these cabinets are intended to be placed where the existing electrical cabling is routed. The placement of the new cabinets will be fixed to their designated locations (shown in Figure 19) unless there is significant reason to relocate.

Interactions with each sub-system: Each of the subsystems that comprise the radiological waste control room is generally operationally independent of each other. Hence, operators should be able to focus on any single subsystem at one time (i.e., with the exception of alarm conditions).

Accessibility: Physical access to the new cabinets should not be obscured.

Support for monitoring: The remaining gaseous and solid radiological waste panel should be visible at a glance when at the new workstation. Indications presented on the new HSIs should be visible at a glance when at the remaining gaseous and solid radiological waste panel. Status of each subsystems presented on this design should be readily visible at all times (i.e., EPRI 4.9.4.1-3 and EPRI 4.9.4.1-4).

Consider HFE design principles: State-of-the-art HFE design principles should be applied to the control room/workstation upgrades. Table 8 describes the applicable guidelines.

Table 8. HFE design guidelines.

| Workstation/ Desk Considerations | |
|--|---|
| <p>11.1.2-5 Display Height and Orientation</p> <p>All displays, including alarm indicators, should be within the upper limit of the visual field (75 degrees above the horizontal line of sight) of the 5th percentile female, and should be mounted so that the interior angle between the line of sight and the display face is 45 degrees or greater.</p> | <p>11.1.2-6 Location of Frequently Monitored Displays</p> <p>Displays that require frequent or continuous monitoring, or that may display important (e.g., alarm) information, should be located not more than 35 degrees to the left or right of the user's straight-ahead LOS, and not more than 20 degrees above and 40 degrees below the user's horizontal LOS, as measured from the normal workstation.</p> |
| <p>11.1.2-8 VDU Viewing Distance</p> <p>The viewing distance should be 13–30 inches (33 to 80 cm), with 18–24 inches (46–61 cm) preferred.</p> | <p>11.1.2-11 Writing Space on Consoles</p> <p>If writing space is needed by users working at consoles, an area at least 16 inches deep and 24 inches wide should be provided, where these dimensions in the total configuration would fit users' reach capabilities.</p> |
| <p>11.1.5-1 Working Space</p> <p>Desks should provide enough clear working space for all materials required for task performance.</p> | <p>11.1.5-2 Chair Positions</p> <p>The desk should allow for different chair positions as required, with adequate knee space.</p> |
| <p>11.1.5-4 Dimensions</p> <p>Desk dimensions should conform to:</p> <ul style="list-style-type: none"> • For seated work only, 26–31 inches above the floor (29 inches is a standard height); for sit-stand desks, 36–38 inches above the floor • Work surface area depth should be 16 inches minimum • Work surface area width should be 24 inches minimum if tasks involve reading and writing only; 30 inches minimum if other kinds of tasks are required • For knee room height, a distance of approximately 25 inches from the floor to the under-surface of the desk top should provide adequate clearance for 5th to 95th percentile male and female adults at sit-down-only stations • For knee room depth, 18 inches minimum • Knee room width should be 20 inches (an even greater width is preferred). | |
| <p style="text-align: center;">Figure 11.9 Recommended desk dimensions</p> | |
| Chair Ergonomic Considerations | |
| <p>11.1.6-1 Mobility</p> <p>Chairs should pivot so that operators can readily adjust position.</p> <p>Additional Information: Mobile bases (casters) are recommended for chairs at sit-only stations.</p> | <p>Chairs should incorporate the following features:</p> <ul style="list-style-type: none"> • 11.1.6-2 Backrests • 11.1.6-3 Armrests • 11.1.6-4 Cushioning • 11.1.6-5 Seat Dimensions (i.e., at least 18 inches wide and between 15 and 17 inches deep) • 11.1.6-6 Seat Adjustability |

| Workplace (i.e., Control Room Configuration) Considerations | |
|---|---|
| <p>12.1.1.3-1 Viewing</p> <p>Desks and consoles should permit users at those desks and consoles full view of all control and display panels (including alarm displays) in the main control room.</p> | <p>12.1.1.3-3 Access to Workstations</p> <p>Users should be able to get to any workstation without having to overcome obstacles such as tripping hazards, poorly positioned filing cabinets or storage racks, and maintenance equipment.</p> |
| <p>12.1.1.3-5 Maneuvering Space</p> <p>Adequate space should be allowed between the back (user's position) of a desk or console and any surface or fixed object behind the user for the user to get into and out of a chair freely or to turn in the chair to view the equipment behind.</p> <p><i>Additional Information:</i> A minimum separation of 36 inches from the back of any desk to any opposing surface is suggested as the minimum. A greater separation is preferable. Lateral space for a seated user should be no less than 30 inches; greater latitude is preferable. Placement and spacing of equipment depends on control room configuration, staffing, and other design features. Thus, guidelines are stated in terms of minimum spacing considerations for common equipment arrangements and use situations. Maintenance and testing of equipment has not been considered, and may require larger clearances than the minimums suggested.</p> | |

2.3.3 Results

The following sub-sections are broken down by Workstation/Desk Selection, Display Arrangement and Placement, Chair Ergonomics, and Workplace/Room Configuration.

2.3.3.1 Workstation/Desk Selection

Based on the anticipated workflow in the radiological waste control room, a sit-stand workstation configuration was considered. This configuration provides flexibility to the operator based on different task demands that may require longer periods of sitting or standing, respectively. While the workstation shown in the 3-D model is not a prescribed solution, this analysis used a representative sit-stand workstation model available for the 3-D model that incorporated sound ergonomic qualities. As such, the CGM Comfortio B3 Operator Desk System workstation model was selected since its footprint could fit within the radiological waste control room workspace. Further, this specific workstation model provides sit-stand capability, measures 77-inches wide and 45-inches deep, and is capable of fitting up to three monitors side by side.

The B3 model has a separate monitor board and work board so that the vertical viewing angle can be adjusted independent of the work board height. A maximum of six 24-inch monitors can be mounted on the workstation, where these would be in a stacked configuration as three monitors wide. Another characteristic of this model that is worth noting is that the overall profile of the B3 model is curved to enhance reach capability throughout the work board; furthermore, this curved profile maximizes the workspace within a smaller area to ensure adequate space for moving about the control room. Figure 20 provides a visual illustration from the 3-D model of these noted ergonomic qualities.

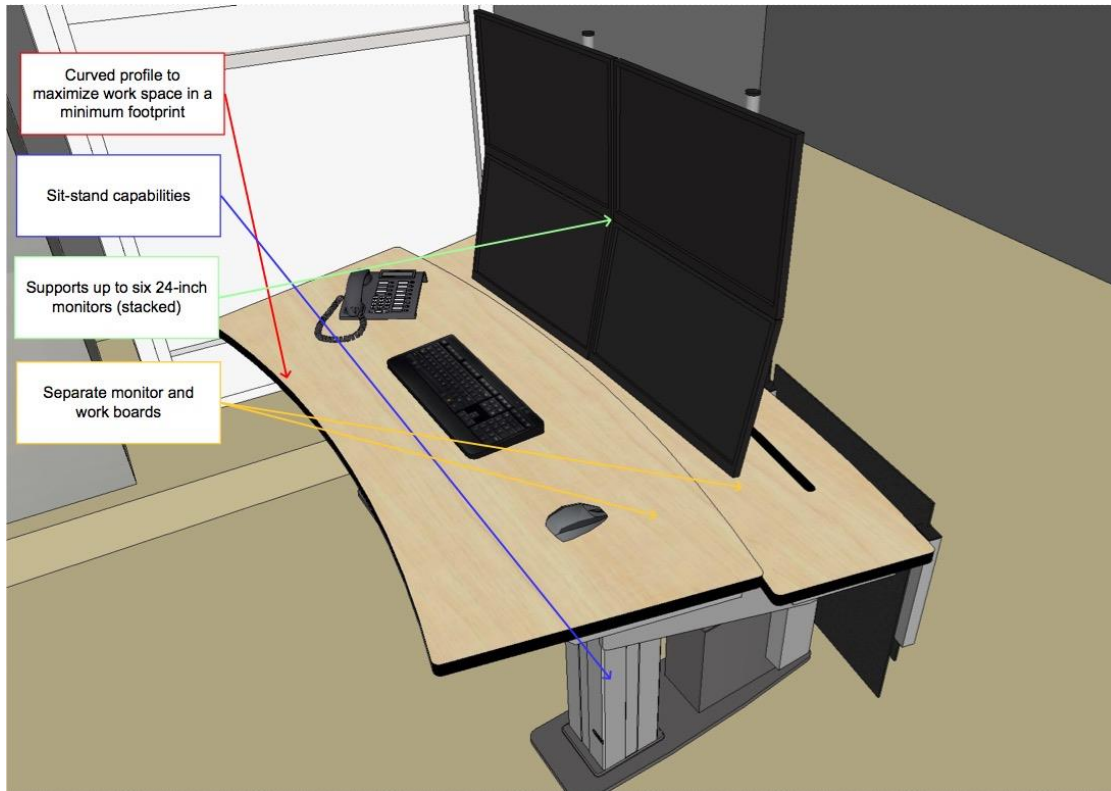

Figure 20. Ergonomic qualities for a prospective workstation/desk.

The B3 model also provides a large work board for writing and performing other tasks not involved with the HSIs. For example, NUREG-0700 11.1.2-11 suggests that an area of at least 16-inches deep by 24-inches wide should be provided for writing activities. A desk like the one shown in the 3-D model yields a much larger space (e.g., 24-inches deep and 77-inches wide), to reasonably accommodate such activities. Further, adequate knee room should be available for operators when in a seated position (e.g., NUREG-0700 11.1.5-2). Figure 21 illustrates how an ergonomic workstation can accommodate even a 95th percentile male in a seated position. Suggested dimensions of a workstation desk are listed in NUREG-0700 11.1.5-4.

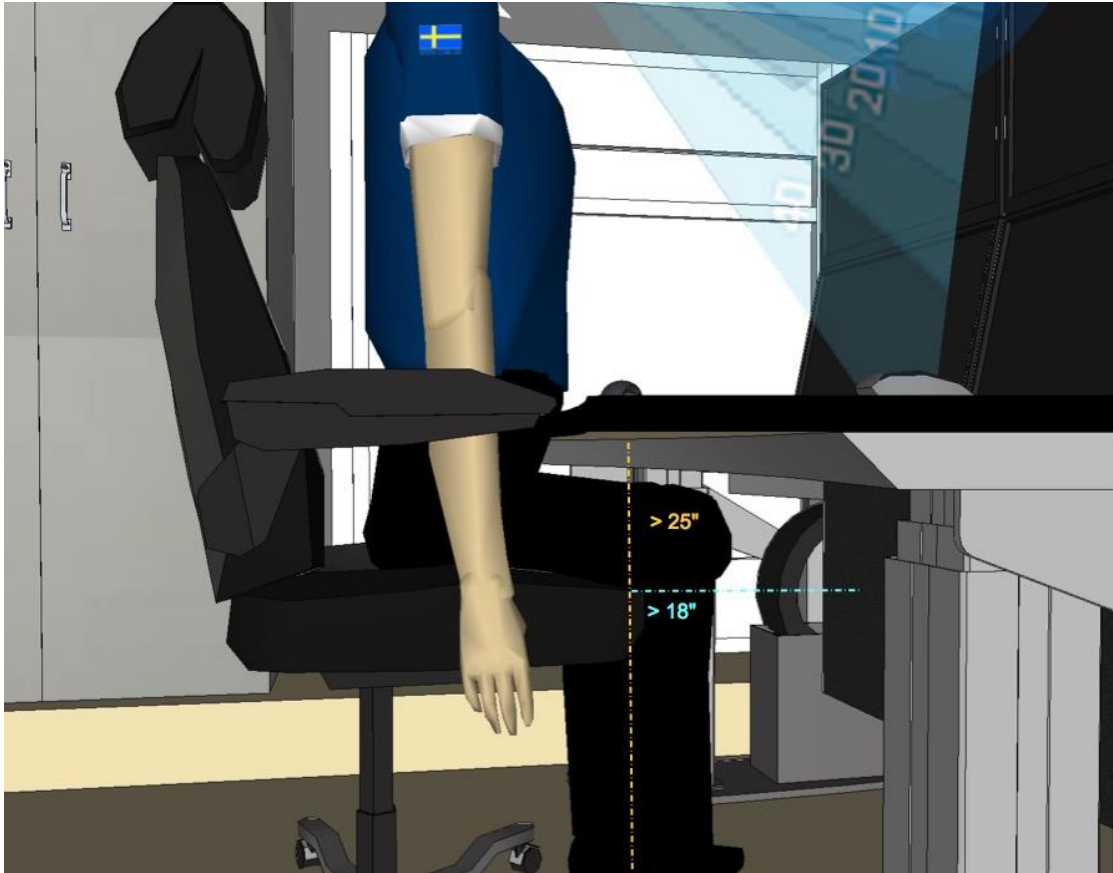

Figure 21. Leg clearance considerations.

2.3.3.2 Display Arrangement and Placement

The HSI display height should be configured so that indications are within the operator's visual field. Specifically, all displays should be within the upper limit of the visual field of 75 degrees (vertical) as described in NUREG-0700 11.1.2-5. Additionally, frequently monitored indications on a display should be no more than 20 degrees above and 40 degrees below the operator's horizontal line of sight; frequently monitored indications should not be outside of 35 degrees to the left or right of the operator's straight-ahead line of sight (i.e., NUREG-0700 11.1.2-6). Likewise, the viewing distance to each monitor is roughly 30-inches (i.e., NUREG-0700 11.1.2-8). These qualities are illustrated in Figure 22 and Figure 23. The red lines present the maximum suggested delta from one's line of sight (in visual degrees). The orange line in Figure 22 depicts a 30-inch viewing distance from the operator seated.

These NUREG-0700 guidelines suggest that a stacked configuration using 24-inch monitors can generally be visually accessible for frequent monitoring, assuming that the workstation can adjust monitor heights independent of the work board. It should be noted, however, that the upper end of the top two monitors would be slightly outside the recommended range for a 5th percentile female. As a result, it is recommended that pertinent information (e.g., alarming) be located elsewhere on the display. A final note worth mentioning is that legibility of information is a function of its size and viewing distance. As such, the size of an object being viewed can be accommodated by increasing its size for further viewing distances. However, certain trade-offs should be accounted for with visual clutter and object size.

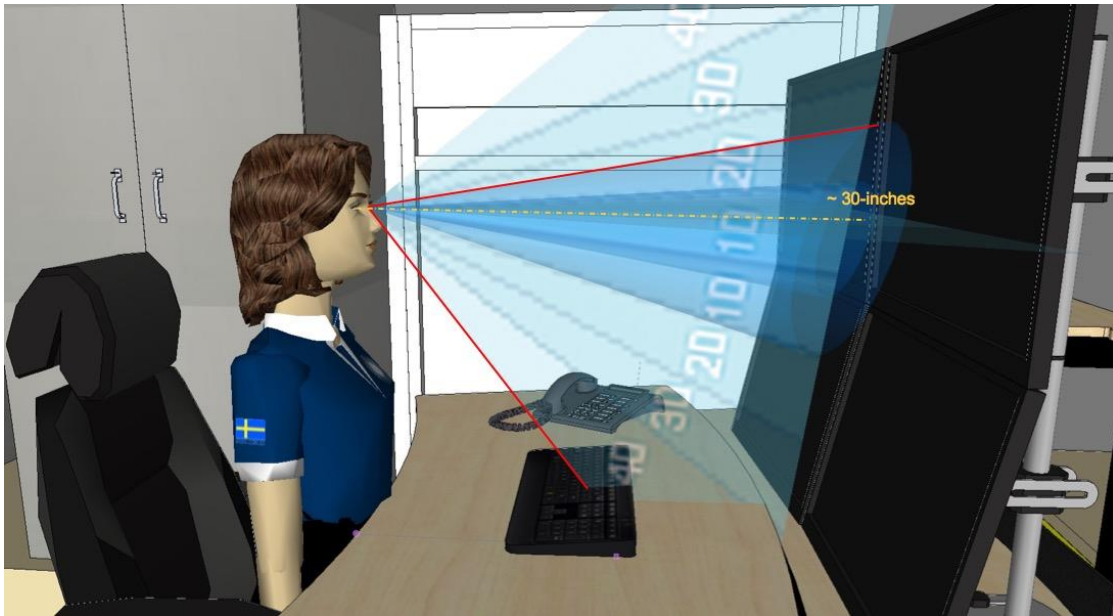

Figure 22. Visual field of operator (horizontal line of sight) considerations.

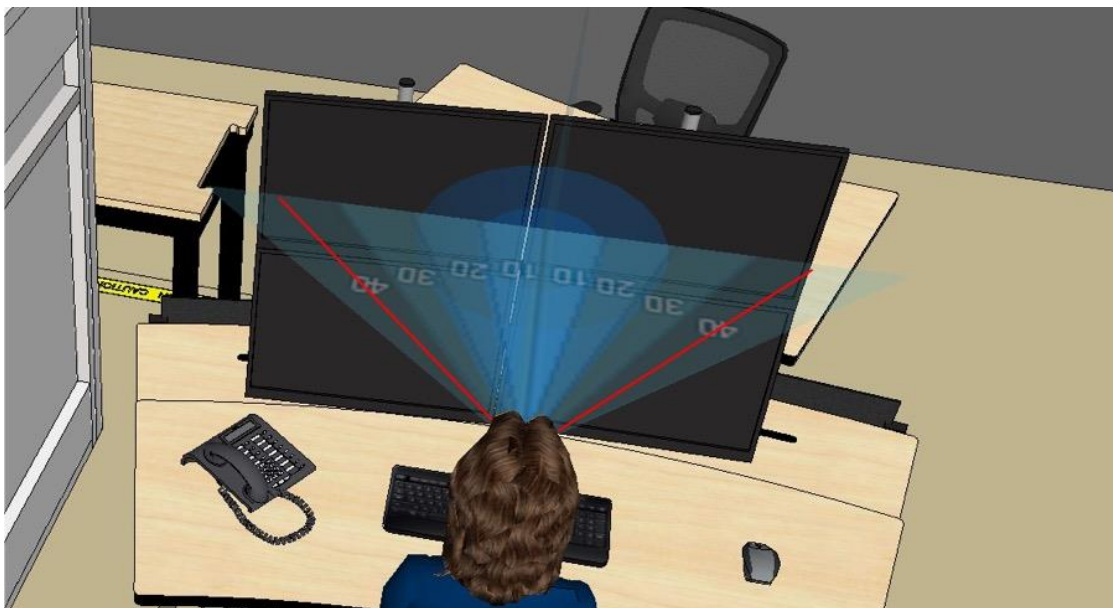

Figure 23. Visual field of operator (straight-ahead line of sight) considerations.

2.3.3.3 *Chair Ergonomics*

An ergonomically sound chair should have the following qualities: mobility (NUREG-0700 11.1.6-1), contain a backrest (NUREG-0700 11.1.6-2), contain armrests (NUREG-0700 11.1.6-3), have cushioning (NUREG-0700 11.1.6-4), have adequate seat dimensions (NUREG-0700 11.1.6-5), provide adjustability (NUREG-0700 11.1.6-6).

2.3.3.4 Workplace/Room Configuration

The preliminary placement and orientation of the workstation accounted for operator viewing requirements, accessibility to the workstation, and maneuvering space when sitting at the workstation. Furthermore, accessibility to each of the new cabinets was an important consideration for the placement of the workstation. Figure 24 shows a possible location for the new workstation that provides:

1. Easy access to the remaining gaseous and solid radiological waste panel.
2. Visibility to the HSI displays when at the remaining gaseous and solid radiological waste panel
3. Accessibility to each of the new cabinets.
4. Adequate space for maneuvering a chair at the workstation.
5. Adequate clearance to walk by the workstation (~37-inches).

It should be noted that while the gaseous and solid radiological waste panel is positioned behind the operator when at the workstation, the operator would be able to rotate his or her chair to orient towards the remaining panel in the event of monitoring the annunciator panel. Additional feedback from operators is needed to verify that this configuration fits their operational needs. To that end, a second option could be to simply rotate the workstation desk 180 degrees so that the operator is facing the panel when viewing the HSI displays. A disadvantage to the latter configuration is that visibility to the HSI when at the panel would be eliminated. The former suggestion (as shown in Figure 24) assumes that the operator may not always be sitting at the workstation.



Figure 24. Workplace (i.e., control room configuration) considerations.

2.4 Functional allocation analysis

As the LRS systems are being modernized only two actual function allocation changes are being proposed, both of which will improve the efficiency of the plant and subject the operators to safer conditions on a regular basis. The two changes are related to the evaporator body reflux flow and the local air instrument regulator from the evaporator steam supply to the surface condenser isolation.

The evaporator body reflux flow (FI 240) is currently stationed as manual. For this particular equipment, operators must physically dress down for possible contamination and travel out into the plant to manually operate the valve. This process is repeated in many steps throughout different procedures. The requirement must sometimes be fulfilled multiple times for one step before it can be checked off. This means an operator must dress down, enter a radiologically controlled area, manually operate the valve, leave the controlled area, dress back up to return to the control room to then ensure the valve position. If the position is not satisfactory, the process is repeated until it is. This can consume a lot of time and subject the operator to the possibility of contamination with each manual action. A new allocation of automation is proposed to improve the efficiency of the plant and to decrease operator's potential exposure. If modernized the operator can check and control the position of the valve from the Liquid Radwaste control room.

The local air instrument regulator from the evaporator steam supply to the surface condenser isolation (HV 229) is conditioned to continually open at no more than 25 percent with an indication of less than 12 psig. For this equipment to operate this condition, it must repeatedly open and close, which can be confusing to the system as well as the operator and can also cause additional attrition to the system. The other allocation of automation is proposed to improve the efficiency of the system and the operator and to reduce the deterioration of the system. This new function allocation of this valve will institute the system to open to the correct percentage and stay open for the appropriate amount of time. As with the rest of the system, the operator will still maintain the ability to manually override if needed.

2.4.1 Operational Sequence Diagram

2.4.1.1 Purpose

An OSD graphically represents a sequence of actions carried out by a team. The composition of the team in this context is the human operators and the equipment, indicators, and controllers they use to achieve a goal. An OSD was described by Brooks (1960) as a realistic description of system operation that helps the design and arrangement of consoles and panels to support human factors. The researchers created an OSD for similar purposes—to help create a simulated prototype of the proposed HSI design using sections of the start up procedure for the evaporator system. The OSD serves to identify all components involved in the procedure section and map their relationships using information from the operator talk-through to supplement the diagram. An OSD provides a quick analysis of potentially complex systems and outputs a graphical depiction organized in a time sequence of all interactions within a single procedure goal.

2.4.1.2 Method

The Effexis Sequence Diagram Editor™ and associated symbology provided the platform for the diagram. First, all identified operators and objects involved in the procedure section were arranged horizontally across the top of the diagram. Using the procedure, each step was mapped using symbols to indicate the associated action or communication. Horizontal arrows marked the direction a command or communication was made between the operators and objects. The notes and cautions contained in the procedure were replicated in the diagram to provide thorough information and reasoning for actions to ensure the prototype design incorporated requisite information to operators. Information gained during the operator talk-through supplemented the diagram where needed.

2.4.1.3 Outcome

A sample OSD created from the start up procedure is shown in **Error! Reference source not found.** The full diagram incorporates the procedure being used for the prototype simulation. The diagram acts as a task analysis of all the actions and roles involved during the start up. The importance of having such a diagram is two-fold. For the purposes of this study, the diagram acts as a check for the development of the simulation being used as part of the workshop wherein new HSI design schemes are evaluated and tested. Although the simulation is limited in functionality, it is important that it is thorough in its replication of the procedure elements to ensure the best possible feedback of operator performance. Also, the diagram acts as a record of the current system's interaction sequence. Creating an OSD from the new design following preliminary tests can be compared to the previous interaction sequence to further identify the changes that may have contributed to the evaluation results.

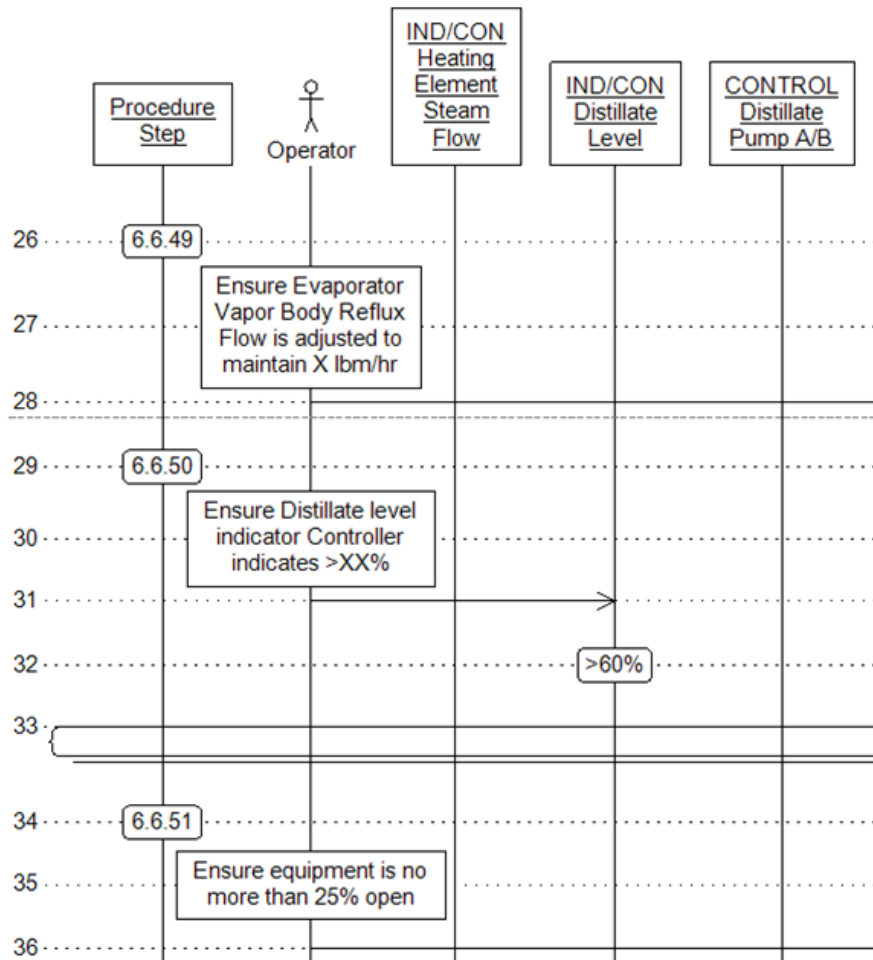

Figure 25. Sample of the operational sequence diagram to support functional allocation and task analysis.

2.5 NUREG-0711 Crosswalk

2.5.1 Purpose

The research and evaluation activities carried out the human factors team not only benefit the operation and maintenance by providing a more usable interface, they also meet the follow the process set forth in NUREG-0711. The human factors team at INL takes measures to ensure that research and evaluation activities are consistent with the guidance detailed in NUREG-0711. To illustrate how research and evaluation activities link to elements laid out in the NRC 0711 Process, researchers developed a NUREG-0711 Crosswalk between the guidance and the research and evaluation activities carried out under this project.

2.5.2 Method

The information in the Crosswalk is summarized or transformed from NUREG-0711. Column 1, “Nureg-0711 Review Element Phase and Purpose” lists the review elements with descriptions of their interrelationships. Column 2, “Methods and Information Sources” consists of both methods called out in the source document and those currently used by the researchers to design and evaluate potential control room technology. Column 3, “Review Element Criteria” is the review element criteria as stated in NUREG-0711. The middle column is the conceptual “crosswalk” drawing connections between how the research team uses methods for each review element to meet the review elements criteria.

Column 1 breaks down each review element. A bulleted list states the impact the review element in question has on all following review elements (**Error! Reference source not found.**). Column 2 compiles the methods used in previous candidate control room technology evaluations and control room workshops performed at INL. Supporting documents and other NRC publications are also included for an HFE team to examine to gain better understanding of the methods employed at INL. It can also be used by INL to help develop a strategy as a new modernization effort begins or moves to another review element. The example also shows a section called “Actions Taken,” an example of how an HF team can use the crosswalk as a live document to track efforts dedicated to each review element. Column 3 lists the review criteria pulled directly from the document. Column three “Phase Review Criteria” has a “minimum” for minimum criteria, and a “detailed” for detailed criteria to provide insight to the range of a particular design phase. Note: some criteria in NUREG-0711 are extensive and, as a result, were reduced to basic expectations for simplification. However, all the information is referenced to specific document locations in case further elaboration is required. It should also be noted that the NRC document is not comprehensive and information outside the criteria may be pertinent. Such decisions should be left up the expertise of the HF team.

| NUREG Evaluation Phase Purpose | INL Actions and Information Collected | Phase Review Criteria |
|---|---|---|
| <p>0711-3.1 Operating Experience Review</p> <p>Purpose:</p> <p>Informs FRA and FA:</p> <ul style="list-style-type: none"> - Basis for initial FA - Identify important HA - Identification of need for modifications <p>Informs TA and HRA:</p> <ul style="list-style-type: none"> - Identify important HA and errors (Human error traps) - Identify Problematic operations and tasks - Instances of staffing shortfalls <p>Informs HSI, Procedures, Training:</p> <ul style="list-style-type: none"> - Identify potential design solutions - Identify potential design issues - Identify tasks to be evaluated <p>HFV&V:</p> <ul style="list-style-type: none"> - Informs event and scenario selection - Performance measure selection - Issue resolution verification | <p>Actions Taken:</p> <ol style="list-style-type: none"> 1. Principal researchers walk down PVNGS Liquid Radwaste Control room with Operator and onsite HF Lead engineer <ol style="list-style-type: none"> a. Gained information on past operation and current operational requirements b. Current HSI human error traps 2. INL team Teleconference with operator and HF lead engineer: <ol style="list-style-type: none"> a. Determined procedure to use b. Task Analysis of procedure c. Current FA and Expected future FA d. Identified Information needed e. Identified HETs of current system f. Clarified difficulties in current system 3. <p>Potential Actions/Sources:</p> <p>Actions include:</p> <ul style="list-style-type: none"> - Personnel interviews - Plant walkthroughs - Plant event database searches - Operator discussions <p>NUREG/CR-6400 provides in-depth info on 4 categories:</p> <ul style="list-style-type: none"> - Unresolved/Generic Safety issues - TMI issues - NRC generic Letter and information Notices - Analysis and evaluation of operational data <p>Basically an expanded version of Appendix B of NUREG 0711</p> <ul style="list-style-type: none"> - Human Factors Information System Database: Find a similar or matching plant | <p>Minimum:</p> <ul style="list-style-type: none"> - Identify predecessor/related plants/systems - Describe methodology - List OE sources - Discuss conducting OER and results - Descriptions of findings - List OER identified issues incorporated into the design - Enumeration of open issues still being tracked in HFE tracking system <p>Detailed:</p> <p>Predecessor/Related Systems:</p> <ul style="list-style-type: none"> - provide information on past performance of predecessor designs - Information on past experiences of HSI designs being used <p>Recognize Industry HFE Issues:</p> <ul style="list-style-type: none"> - NUREG 0933 - TMI issues - OER in NUREG-1275 series - Low power/shutdown ops - Plant event reports <p>Related HIS Technology:</p> <ul style="list-style-type: none"> - Cover any experience with proposed HSI Tech <p>Issues ID'd by Plant Personnel:</p> <p><i>Plant Operations:</i></p> <ul style="list-style-type: none"> - Interview OPS about -> - Normal plant ops - Fail modes and I&C conditions - Degraded conditions of HSI resources - Transients - Accidents - Reactor shutdown and cooldown <p><i>HFE Design Topics:</i></p> <ul style="list-style-type: none"> - Alarms and Annunciators - Displays - Controls/automation - Info processing and job aids - Real-time communications with plant personnel |

Figure 26. Sample of NUREG-0711 Crosswalk.

2.5.3 Outcome

The Crosswalk is a reference document mapping the methods employed at INL for control room modernization to review elements and criteria of the “Planning and Analysis” in NUREG-0711 Section 1.2.2, Figure 1-1, Elements of the HFE program’s review model (Figure 27). The Crosswalk is an important tool for communicating how the human factors process drives a successful modernization effort. It can communicate to any nuclear power generating facility how to thoroughly address each review element of the NUREG-0711 review guideline and, therefore, stands out from other program plans that are plant specific such as a HFE program management plan.

The reference document (i.e., found in Kovesdi et al., 2017)) is organized into three columns. The first is the NUREG-0711 Review Element Phase and Purpose. The second column is Methods and Information Sources. The third column is the Review Element Criteria.

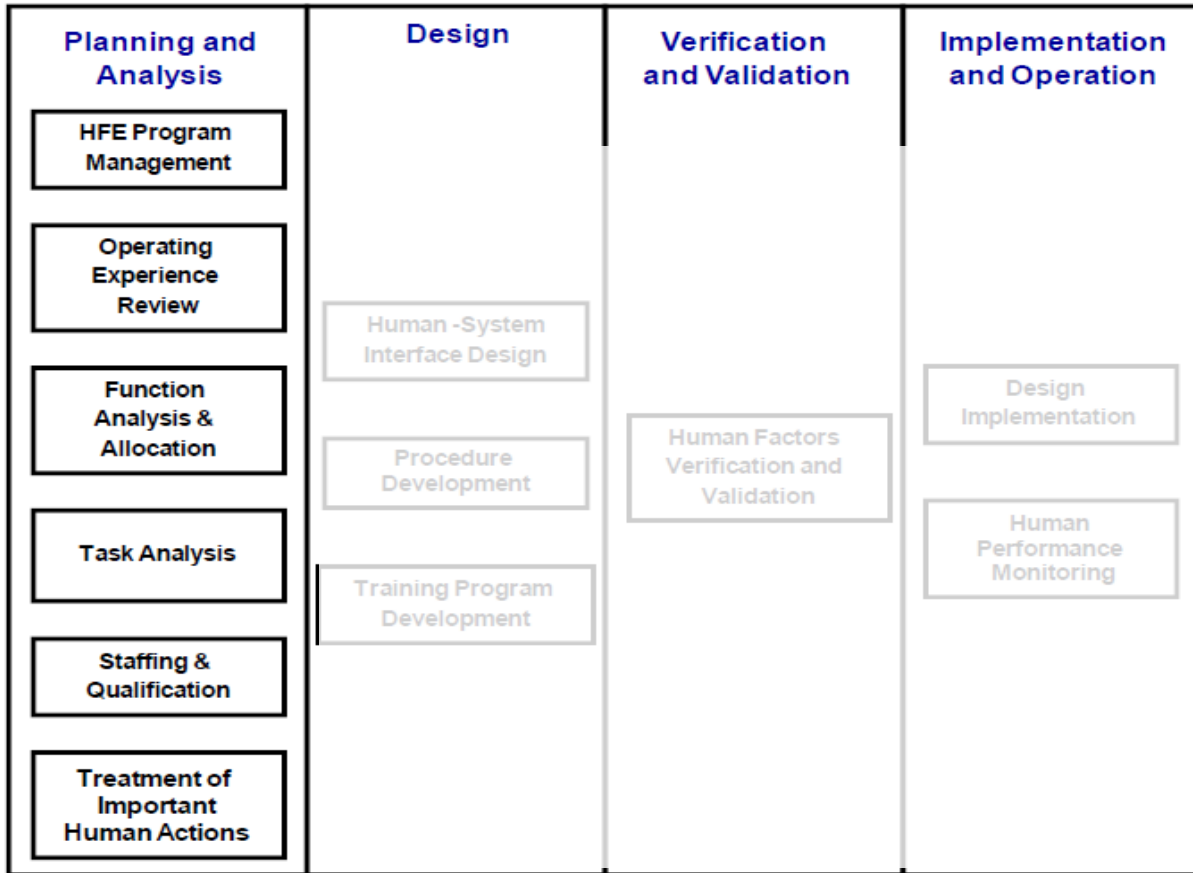

Figure 27. Depiction of HFE elements completed per Figure 1-1 of NUREG-0711.

The second column is the Crosswalk portion of the document. It lists potential HFE methods as well as supplemental sources. The list and its location in the second column represent the connection to the review element and the output expected after completing a review element. Informative and methodological references are also included to supplement the suggested actions. If used as a live document during a modernization, it is in the second column the HFE team could track the actions carried out placing them in their appropriate review element row. Doing so may support the HFE team's effort as well as act as a status update to the utility. Delivering a status update in this way can efficiently communicate both why specific methods were used, and how they will benefit the effort during verification and validation.

The Crosswalk is also useful as a checklist for the HFE team. The document provides an initial outline for the HFE program plan. If treated as a live document during a modernization gaps in the methodology or review elements can be quickly spotted and addressed. When documenting each effort, the third column provides a checklist for the information each document should contain or be accounted for to meet review element criteria.

The Crosswalk document currently only accounts for the Planning and Analysis Phase of NUREG-0711's program review model. Expansion to the following phases would be beneficial to the entire process and should be considered. The Crosswalk is a tool that promotes communication between all entities involved in a control room modernization. It acts as a reference document that clearly defines expectations for each review element outlined by the NRC. Due to the transparency the document lends to the process, smoother verification and validation outcomes are expected as well.

2.6 2018 March Operator Workshop

2.6.1 Soft Control Evaluation

This section describes the soft control evaluation performed to support the selection and implementation of the soft control scheme for the prospective dynamic overview displays for the LRS. A summary of findings is first reported followed by detailed sections regarding this evaluation's method and results. The researchers designed two different soft control presentations, which were evaluated in the study. The first presentation displays the soft control faceplate in close proximity to the component to be manipulated, this design is referred to as collocated soft control. The second presentation has a dedicated faceplate region on either the lower left or lower right side of the display. The two presentations are shown in Figure 28.

2.6.1.1 Summary of the Soft Control Evaluation

The two different soft control presentations (colocated versus dedicated faceplate region that displays on the right or left side of the display) were compared using a total of twelve ($n = 12$) operators in a performance-based evaluation using a series of basic control tasks with an embedded simulated monitoring task.

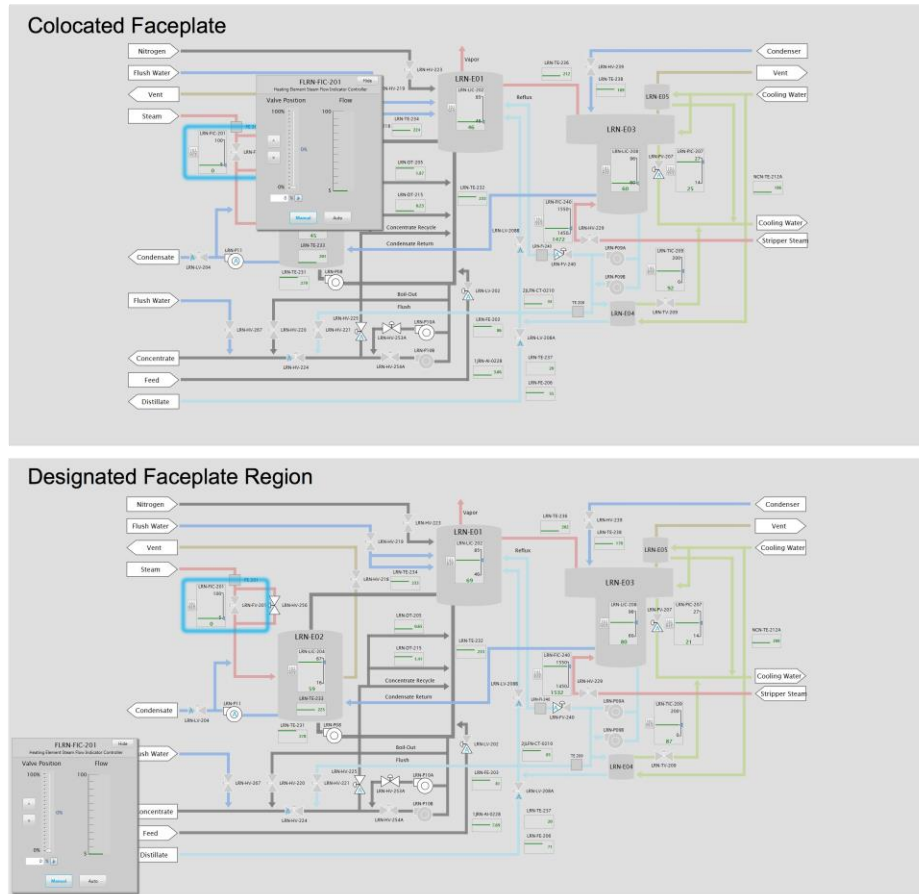

Figure 28. Soft control design schemes evaluated.

Measures of task performance, perceived workload, overall usability, and soft control preference were collected in this evaluation. Hence, the following research questions were addressed in this phase of research:

1. Is there a significant difference in *primary task performance* (i.e., to perform process control actions) between the two soft control design options? What option offers greatest task performance?
2. Is there a significant difference in *secondary task performance* (i.e., to perform interface management actions like accessing a control) between the two soft control design options? What option places the least secondary task demands on the operator?
3. Is there a significant difference in *workload* between the two soft control design options? What option places the least demand on workload?
4. Is there a significant difference in *perceived usability* between the two soft control design options? What option places the least demand on usability?
5. What soft control design option was most preferred (and why)? What soft control design option was least preferred (and why)? How important is it to operators to reduce occluding information from a soft control faceplate? How important is it to operators to reduce cursor and eye movements when using the soft controls? Do any of the soft control design options pose risk of an error-prone situation?

Results from the soft control evaluation suggest that the preferred soft control design option is the collocated option when seated at a workstation and presented with a mimic display and performing a simple task such as changing the state of a pump or valve with a mouse. Operators ranked the collocated option as the most preferred and commented that the design would reduce eye fatigue when visually linking information from the soft control region to the indications and components being controlled on the mimic display. There was, however, little difference observed from a human-system performance perspective between the collocated and designated soft control region. Most operators (11 of 12) did not drag the collocated soft control faceplate during the evaluation, which reduced the amount of cursor movement needed to make control actions. The time spent performing control actions were similar for both designs. Collectively, the results from the soft control evaluation suggest that there is little difference in human-system performance between a designated soft control faceplate compared to the collocated faceplate when performing basic control actions. However, operators do prefer having the soft controls available collocated to the component/indication being controlled on the mimic display. A key takeaway from this evaluation is that the collocated faceplate offers similar performance for basic control actions compared to the designated faceplate and is the preferred option by operators, so long as the tasks are: (1) seated at a workstation using a mouse; and (2) do not require use of multiple soft controls in short succession.

2.6.1.2 Method

This section describes the basis for evaluation, participant characteristics, data collection process, and measures used in this evaluation.

2.6.1.2.1 Basis for Evaluation

Two unique soft control design schemes have been proposed and/or previously used in HSI displays with the integration of soft controls with displays that are presented in a mimic format. These designs are presented below in Table 9.

Table 9. Soft control tradeoffs.

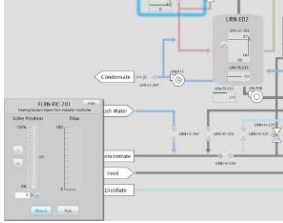
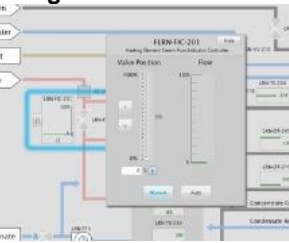
| | |
|---|--|
| <p>Dedicated Display Area on Same Display with Components Being Controlled</p>  <p>Soft controls have their own dedicated area, but on the same display as the components being controlled.</p> | <p>Advantages:</p> <ol style="list-style-type: none"> 1. Ensures that there is adequate display area per NUREG-0700 7.2.5-1¹ (i.e., does not occlude long-term monitoring information while performing short-term control actions). 2. Does not require a dedicated visual display unit (VDU) for soft controls. 3. Provides a consistent location concerning where controls will be located on the display. <p>Disadvantages:</p> <ol style="list-style-type: none"> 1. Requires a dedicated display region on the HSI display. Often, this can create clutter or require a larger VDU to balance readability requirements. |
| <p>Dedicated Display Area on Colocated with Components Being Controlled</p>  <p>Soft controls appear in window within close proximity to component being controlled.</p> | <p>Advantages:</p> <ol style="list-style-type: none"> 1. Does not require a dedicated VDU for soft controls. 2. Does not require a dedicated display region for soft controls. 3. Provides maximum 'location compatibility.' <p>Disadvantages:</p> <ol style="list-style-type: none"> 1. May not ensure that there is adequate display area per NUREG-0700 7.2.5-1¹ (i.e., does not occlude long-term monitoring information while performing short-term control actions). Requires careful consideration of where the secondary window appears in relation to important information from the HSI display or ability to drag the secondary window. Alternatively, the HSI could have a dedicated region for critical parameters where the secondary window cannot occlude. 2. The location of the soft controls is not located in a consistent/dedicated area. |

To understand how these tradeoffs between a designated soft control faceplate region and colocated faceplate scheme, this evaluation compared human-system performance and preference through measures of task performance, perceived workload, overall usability, and soft control preference within the context of the radiological waste control room.

2.6.1.2.2 Participant Characteristics

A total of twelve ($n = 12$) operators completed the soft control evaluation. The average age was ($M = 35.2$, $SD = 9.4$) years with average experience at PVGS of ($M = 6.7$, $SD = 10$) years. Six operators reported that they have operated the LRS. Operators were asked how 'tech savvy' they believed they were on a scale 1-7 (1 = Novice; 7 = Expert). The average rating was ($M = 5.1$, $SD = 0.9$), indicating the operators who completed the soft control evaluation generally believed they were experienced with technology (e.g., computers, smart phones, and tablets).

2.6.1.2.3 Data Collection Process

The soft control evaluation was performed using a 27-inch 2560 by 1440 resolution monitor. The viewing distance was roughly 30-inches away to simulate the suggested specifications for a new seated workstation from the ergonomic evaluation in INL-EXT-17-43226. Figure 29 illustrates the workflow used.

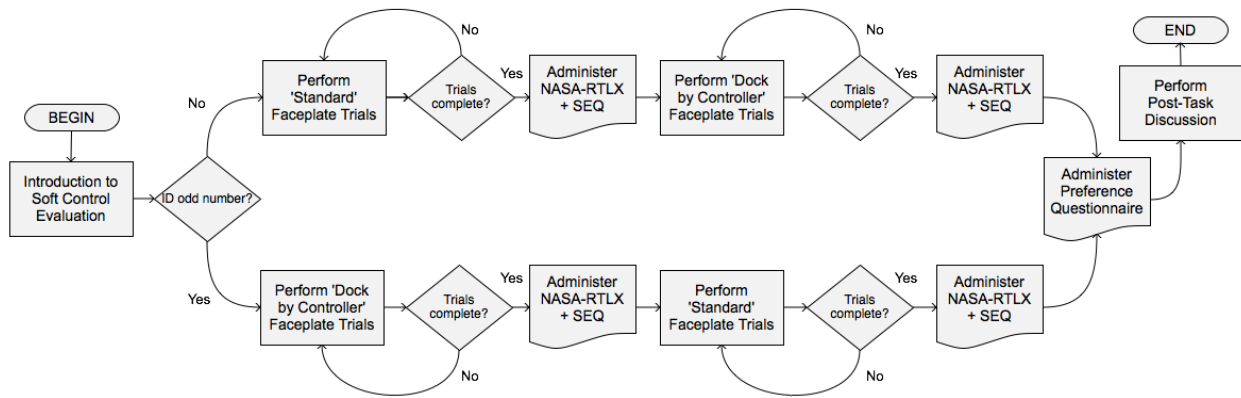

Figure 29. Soft control evaluation data collection process.

For each condition, there were initially a total of 20 trials where 10 are without a monitoring task and 10 are with a monitoring task. See the Table 10 below.

Table 10. Soft Control Block Design.

| | Standard | Dock by Controller |
|--------------------|-----------------------------|-----------------------------|
| Without Monitoring | A1 ^b : 10 Trials | B1 ⁴ : 10 Trials |
| With Monitoring | A2: 10 Trials | B2: 10 Trials |

An example trial for A1/B1 (Without Monitoring) was:

“Open LRN-HV-219.”

An example trial for A2/B2 (With Monitoring) was:

“Place LRN-LIC-202 in Manual and Report Level in LRN E01.”

However, given the constraints of time per operator, A1 and B1 were dropped after the initial participant to save time. Results given in this report are hence from A2 and B2. After data collection for each embedded soft control concept was completed, the NASA-RTLX and SEQ questionnaire packet was administered to the operator. Upon completing both conditions, the preference questionnaire was administered. Upon completing the preference questionnaire (and as time permitted), a post-task discussion was performed to query additional operator feedback regarding their rationale for the preference questionnaire responses. Likewise, if there are noticeable differences in workload from the NASA-RTLX or SEQ, a follow-up interview was completed during this time. Data was recorded in a spreadsheet.

2.6.1.2.4 Selected Measures and Analyses Used

Table 11 outlines the measures used for the soft control evaluation.

^b If time is limited, A1 and B1 (Without Monitoring) trials would be skipped to save time.

Table 11. Description of selected measures for the soft control evaluation.

| | |
|--|---|
| <p>Measures of Task Performance and Usability</p> | <ol style="list-style-type: none"> 1. <i>Time spent performing specific control actions</i> – The time spent performing specific control actions was measured from the time the operator selected a component on the mimic display to the time the control action was completed (e.g., change a pump from auto to manual) and selected the ‘Hide’ button. Less time required to complete a task, is indicative of greater performance (all things equal). 2. <i>Control action efficiency</i> – The number of control actions completed per unit time (in seconds). This measure captures elements of efficiency by creating a ratio of steps completed per time taken (Tullis & Albert, 2008). Greater control action efficiency would be indicative of greater performance. 3. <i>SEQ</i> – A standardized single-question post-trial subjective rating method, using a 1-7 rating scale (1 = Very Difficult; 7 = Very Easy) to measure perceived ease of completing a task. The SEQ is a widely used tool in usability engineering for software systems. Lower SEQ values denote lower perceived ease of task completion whereas higher SEQ values denote higher perceived ease of task completion. |
| <p>Measures of Secondary Task Performance</p> <p>Per NUREG-0711 11.4.3.5.1(3): “secondary tasks are those personnel must perform when interfacing with the HSI, such as navigating through computer screens to find a needed display and to configure HSIs. The measurement of secondary task performance should reflect the demands of the detailed HSI implementation, e.g., time to configure a workstation, navigate between displays, and manipulate them (e.g., changing display type and scale settings).”</p> | <ol style="list-style-type: none"> 1. <i>Total cursor movement</i> – The amount of cursor movement (in pixels) required for completing a control task. For instance, having to move the cursor further to the soft control faceplate would create greater total cursor movement. Likewise, having to drag a faceplate would also create greater total cursor movement. 2. <i>Drag Frequency</i> – The frequency of times an operator dragged the soft control faceplate out of the way of an indication if occluded. Greater drag frequency is indicative of more secondary task interference. 3. <i>Drag Distance</i> – The distance (in pixels) the soft control faceplate was moved. Greater drag distance is indicative of more secondary task interference. |
| <p>Measures of Workload</p> | <ol style="list-style-type: none"> 1. <i>NASA-RTLX</i> – The NASA-RTLX is a standardized post-trial subjective rating method, using a 1-20 rating scale to measure perceived workload (1 = Low; 20 = High). The NASA-RTLX consists of six questions, each pertaining to a unique workload sub-scale of: [1] Mental Demand, [2] Physical Demand, [3] Temporal Demand, [4] Effort, [5] Performance, and [6] Frustration. A cumulative workload score can be created by summing the values of each sub-scale rating. Lower values denote lower perceived workload whereas higher values denote higher perceived workload. Since the NASA-RTLX is arguably the most widely used workload assessment tool in HFE, there are numerous studies that have investigated normative workload values to compare to. One such study by Grier (2015) provides normative workload values for process control HFE studies. |
| <p>Measures of Preference</p> | <ol style="list-style-type: none"> 1. <i>Preference Questionnaire</i> – The preference questionnaire is a customized questionnaire that was administered post session. Operators ranked the four-different soft control design options from their most to least preferred where they provided their rationale for most and least preferred. Additional questions were provided to query how important it was for them to [1] minimize information occlusion, [2] minimize cursor movement when performing a control action, and [3] minimize eye movements when performing a control action. There were also questions whether any of the design options may introduce an error prone situation where operators could explain in detail potential issues they see from an operational context. Finally, a question was provided asking to rate how natural the soft control evaluation tasks were compared to actual plant operations. |

Statistical analyses were performed on the data collected during this evaluation. Specifically, interval and ratio scale measures used to compare the two soft control design options under the performance-based evaluation were analyzed using inferential statistics such as paired t-tests ($\alpha = .05$). Individual trials were aggregated in preparation for analysis. Outliers were determined as values two standard deviations above or below the group mean and removed before aggregating. Instances of potential outliers would be cases where operators were distracted during a given trial. With this, observational data

collected during the performance-based evaluations were included to support findings made from the inferential statistics.

Categorical (i.e., ordinal scale) variables that were expressed as binary outcomes were analyzed using Fisher Exact tests ($\alpha = .05$). Proportions for preferences were analyzed using a two-tailed one-sample exact binomial test where the option with the greatest selection was tested using a test proportion of 25 percent (e.g., one of four design options). In other words, the binomial test was set to test whether the proportion of the top selected design option significantly differed from chance. Other self-report measures from the preference questionnaire that were not used for comparative purposes were analyzed descriptively.

2.6.1.3 Results

This section describes the results and findings from the soft control evaluation. Table 12 summarizes the results for the performance-based evaluation.

Table 12. Summary results of soft control evaluation.

| Type | Measure | Conditions – Mean (Standard Deviation) | | Statistical Difference? |
|--|---|--|----------------------|-------------------------|
| | | Colocated | Designated Faceplate | |
| Primary Task Performance and Usability | Time spent performing control actions (seconds) | 7.31 (3.89) | 7.96 (3.35) | ✘ No |
| | Control action frequency (counts) | 3.15 (0.29) | 3.08 (0.18) | ✘ No |
| | SEQ (rating) | 6.00 (0.95) | 5.92 (0.51) | ✘ No |
| Secondary Task Performance | Total cursor movement (pixels) | 813.27 (217.58) | 1324.35 (194.09) | ✔ Yes |
| | Drag Frequency (counts) | 1 operator | 0 operators | ✘ No |
| | Drag Distance (pixels) | 7.04 (24.40) | 0 (0) | ✘ No |
| Workload Ratings | NASA-RTLX (Overall) | 16.46 (10.65) | 16.53 (9.44) | ✘ No |
| | NASA-RTLX (Mental) | 4.08 (3.18) | 3.75 (2.42) | ✘ No |
| | NASA-RTLX (Physical) | 2.08 (1.83) | 2.33 (2.27) | ✘ No |
| | NASA-RTLX (Temporal) | 2.75 (2.83) | 2.67 (2.53) | ✘ No |
| | NASA-RTLX (Performance) | 2.33 (1.72) | 2.25 (2.53) | ✘ No |
| | NASA-RTLX (Effort) | 3.92 (2.43) | 3.83 (2.63) | ✘ No |
| | NASA-RTLX (Frustration) | 4.58 (3.73) | 5.00 (3.81) | ✘ No |
| <i>n</i> = 12 | | | | |

2.6.1.3.1 Primary Task Performance and Usability

Time spent performing control actions. There was no statistical difference observed for *time spent performing control actions* between soft control design options, $t(11) = 0.53$, $p = .60$. Time spent performing control actions for the colocated design ($M = 7.31$, $SD = 3.89$) was similar to the designated faceplate design ($M = 7.96$, $SD = 3.35$).

Control action frequency. There was no statistical difference observed for *control action frequency* between soft control design options, $t(11) = -0.68$, $p = .51$. The frequency of control actions for the colocated design ($M = 3.15$, $SD = 0.29$) was similar to the designated faceplate design ($M = 3.08$, $SD = 0.18$).

SEQ. There was no statistical difference observed for *SEQ* ratings between soft control design options, $t(11) = -0.23$, $p = .82$. Perceived task difficulty (measured by SEQ) for the colocated design ($M = 6.00$, $SD = 0.95$) was similar to the designated faceplate design ($M = 5.92$, $SD = 0.51$). To note, both

ratings were considerably high as the industry average for SEQ is 5^c, indicating that both designs were perceived as being easy when performing the tasks in this evaluation.

2.6.1.3.2 Secondary Task Performance

Total cursor movement. There was a statistical difference observed for *total cursor movement* between soft control design options, $t(11) = 5.22, p = .0003$. Total cursor movement for the colocated design ($M = 813.27, SD = 217.58$) was significantly less compared to the designated faceplate design ($M = 1324.35, SD = 194.09$). See Figure 30.

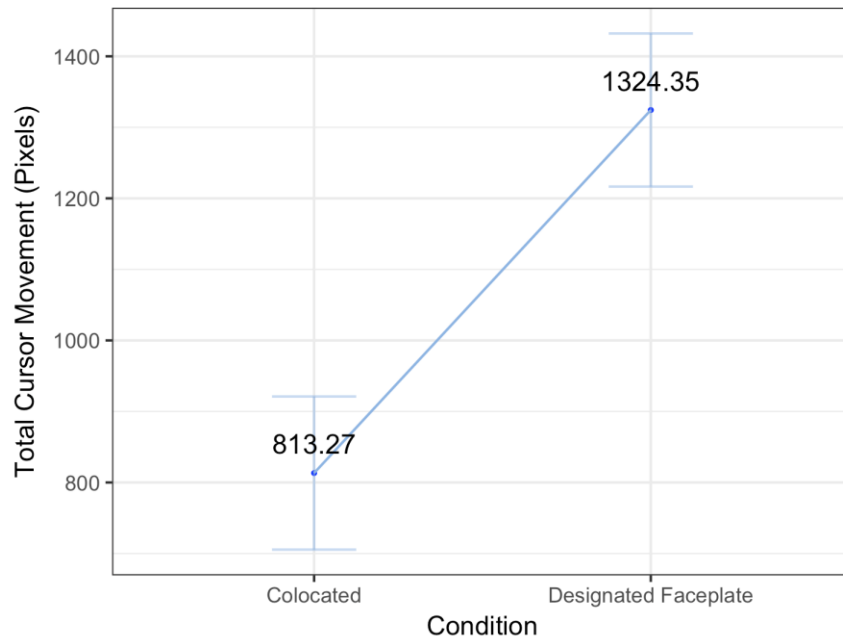

Figure 30. Colocated versus Designated Faceplate: Total cursor movement comparison.

Dragging frequency. There was no statistical difference observed for *dragging frequency* between soft control design options, $p = 1$. Only one operator was observed dragging the faceplate with the colocated soft control.

Dragging distance. *Drag distance* for the colocated design was not statistically significant from 0, $t(11) = 1.00, p = .34$. Drag distance for the colocated design ($M = 7.04, SD = 24.40$) was not statistically greater than 0, or from what the designated faceplate design ($M = 0.00, SD = 0.00$) would require.

2.6.1.3.3 Workload

Mental demand. There was no statistical difference observed for *mental demand* between soft control design options, $t(11) = 0.49$, $p = .63$. Mental demand ratings for the colocated design ($M = 4.08$, $SD = 3.18$) were similar to the designated faceplate design ($M = 3.75$, $SD = 2.42$).

Physical demand. There was no statistical difference observed for *physical demand* between soft control design options, $t(11) = -0.43$, $p = .67$. Physical demand ratings for the colocated design ($M = 2.08$, $SD = 1.83$) were similar to the designated faceplate design ($M = 2.33$, $SD = 2.27$).

Temporal demand. There was no statistical difference observed for *temporal demand* between soft control design options, $t(11) = 0.22$, $p = .83$. Temporal demand ratings for the colocated design ($M = 2.75$, $SD = 2.83$) were similar to the designated faceplate design ($M = 2.67$, $SD = 2.53$).

Performance. There was no statistical difference observed for *performance* between soft control design options, $t(11) = 0.19$, $p = .85$. Performance ratings for the colocated design ($M = 2.33$, $SD = 1.72$) were similar to the designated faceplate design ($M = 2.25$, $SD = 2.53$).

Effort. There was no statistical difference observed for *effort* between soft control design options, $t(11) = 0.11$, $p = .92$. Effort ratings for the colocated design ($M = 3.92$, $SD = 2.43$) were similar to the designated faceplate design ($M = 3.83$, $SD = 2.63$).

Frustration. There was no statistical difference observed for *frustration* between soft control design options, $t(11) = -0.31$, $p = .76$. Frustration ratings for the colocated design ($M = 4.58$, $SD = 3.73$) were similar to the designated faceplate design ($M = 5.00$, $SD = 3.81$).

Overall workload. There was no statistical difference observed for *overall workload* between soft control design options, $t(11) = -0.02$, $p = .98$. Overall Workload ratings for the colocated design ($M = 16.46$, $SD = 10.65$) were similar to the designated faceplate design ($M = 16.53$, $SD = 9.44$).

General observations. Workload across dimensions and overall were very similar between soft control designs (see Table 12). Generally, both design options had noticeably low workload ratings. Three operators explicitly commented during data collection that they ‘did not notice a difference between the design options.’ Additionally, the one operator who dragged the faceplate for the colocated design option had noticeably higher workload values when using the colocated design versus the designated faceplate design. When following up with his responses, the operator commented that the difference in ratings were attributed to having to drag the faceplate.

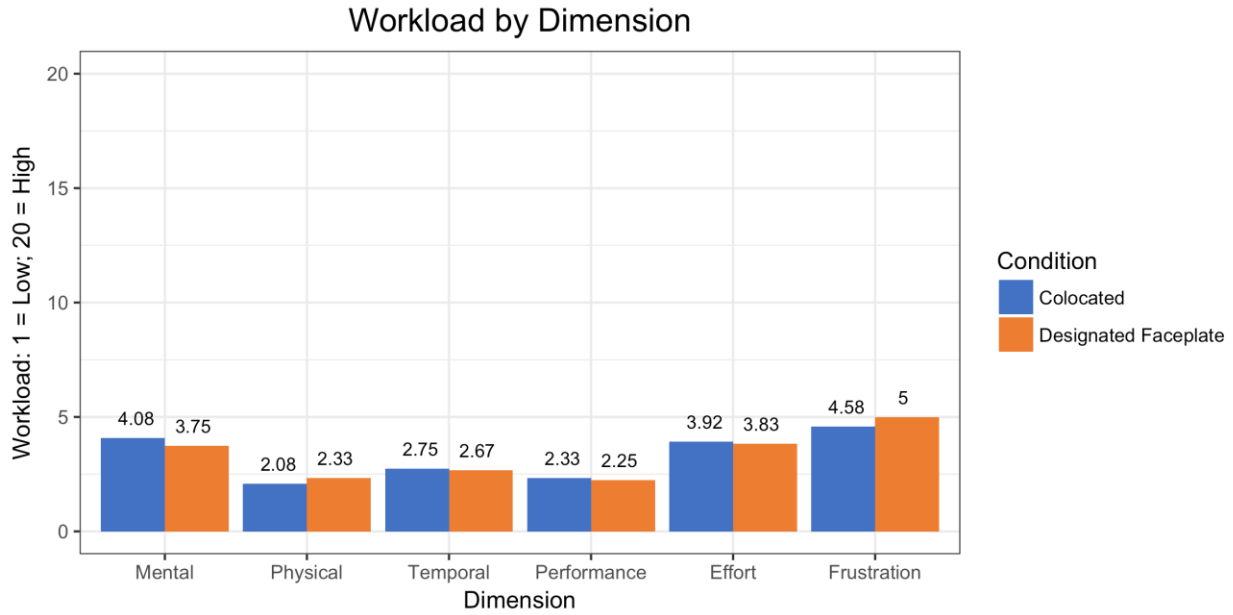

Figure 31. NASA-RTLX responses between colocated versus designated faceplate designs.

2.6.1.3.4 Preference

Questions related to: (1) most preferred, (2) least preferred, and (3) whether any of the four design options provided may introduce an error prone situation were listed in the preference questionnaire. A key for these design options are provided below in Figure 32.

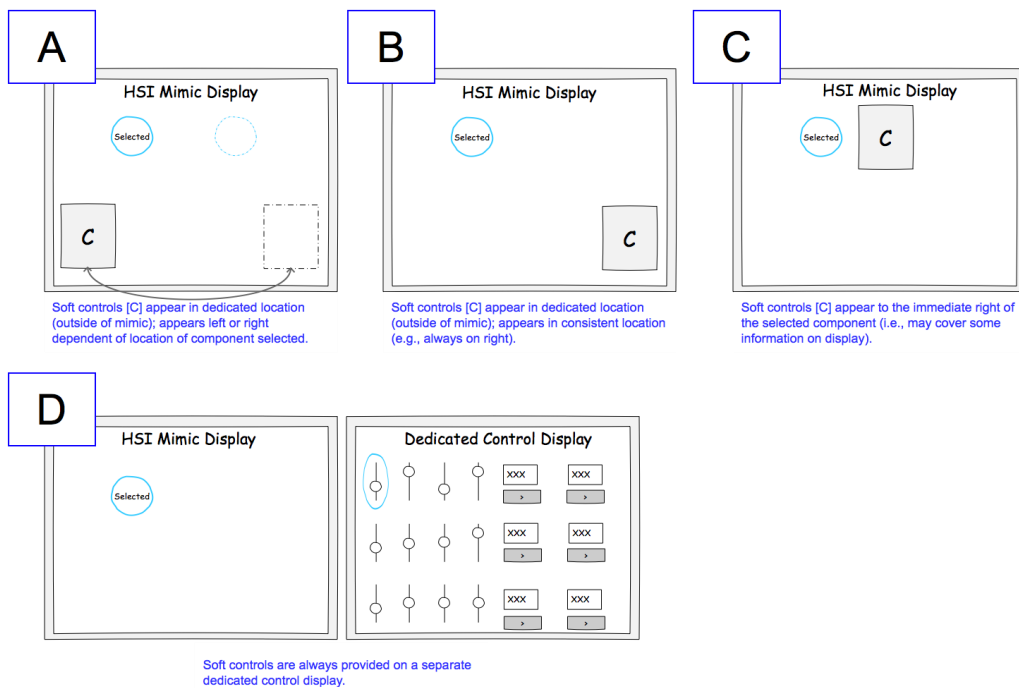

Figure 32. Illustrated soft control schemes for preference evaluation.

Most preferred. Design option C (colocated) was the most preferred design option, $p = .0028$. In general, the majority of operators (8 of 12) preferred design option C (colocated) compared to the other options. A common response was that option C allows for ‘less visual navigation’ to visually link the controls with the component being operated from the mimic display. Operators generally commented that the colocated design keeps the ‘eyes trained in one spot rather than hunting for indications.’ Interestingly, one operator who preferred option D commented that having multiple controls available would be helpful when making changes to multiple controls in manual. See Figure 33.

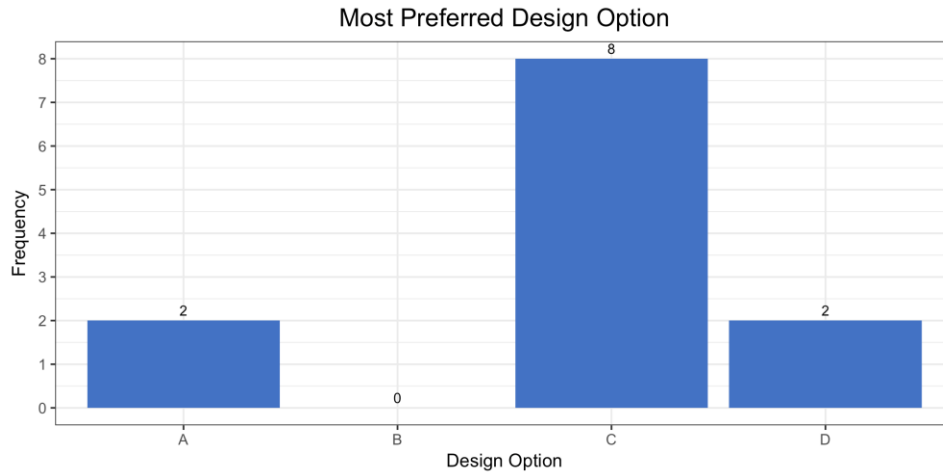

Figure 33. Most preferred response characteristics.

Least preferred. Design option D (separate dedicated control display) was the least preferred design option, $p = .001$. In general, the majority of operators (8 of 11) ranked design option D (separate dedicated control display) as their least preferred option compared to the others. A common response was that option D presented the controls ‘too far away’ from the indications and components on the mimic display. Operators thought that the design of option D would be easier to confuse controls with their corresponding components and ‘divides attention.’ See Figure 34.

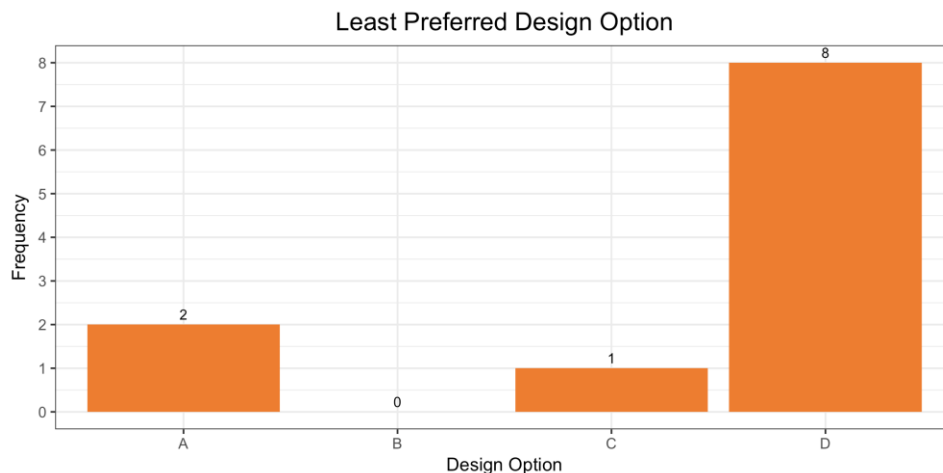

Figure 34. Least preferred response characteristics.

Potential for error prone situations due to design. The overall 4 x 2 Fisher Exact test showed that the distribution of responses statistically differed across design options, $p = .034$. Upon visual inspection,

design option D (separate dedicated control display) presented noticeably more ‘Yes’ responses (i.e., that the design would introduce an error prone situation) compared to the other design options. Separate 2x2 Fisher Exact tests were performed to investigate whether these distributions do statistically differ. Results showed that option D had statistically more ‘Yes’ responses compared to design options A and B, $p = .036$, respectively. There was a marginally significant effect observed with design option D to C, $p = .1$. See Table 13 below for a reference to operator response characteristics.

Table 13. Operator Opinions: Potential for Error Prone Situation Due to Design of Soft Control Schemes.

| | No | Yes |
|------------------------|--------------|-------------|
| Design Option A | 10 Operators | 2 Operators |
| Design Option B | 10 Operators | 2 Operators |
| Design Option C | 9 Operators | 3 Operators |
| Design Option D | 4 Operators | 8 Operators |

A common rationale for indicating that design option D could introduce an error prone situation was that their eye movements would be spaced too far away from the component and indications being controlled if the controls were separated on a different display. As a result, operators would have to look ‘back and forth’ dividing their attention. Three operators commented that option C could introduce an error prone situation if important information (e.g., FE/TE) were occluded by the faceplate. Two operators commented that option B could introduce an error prone situation because the design requires moving one’s attention away from the selected component. Finally, two operators commented that option A could introduce an error prone situation; one operator believed that distance from control to indication was still too far and the other operator commented that having the faceplate appear in one of two spots could be confusing.

Rating importance of minimizing occlusion, cursor movement, and eye movement.

Descriptively, operators rated minimizing occlusion as less important and rated minimizing eye movements closest to ‘very important.’ Figure 35 shows average ratings for each importance question type.

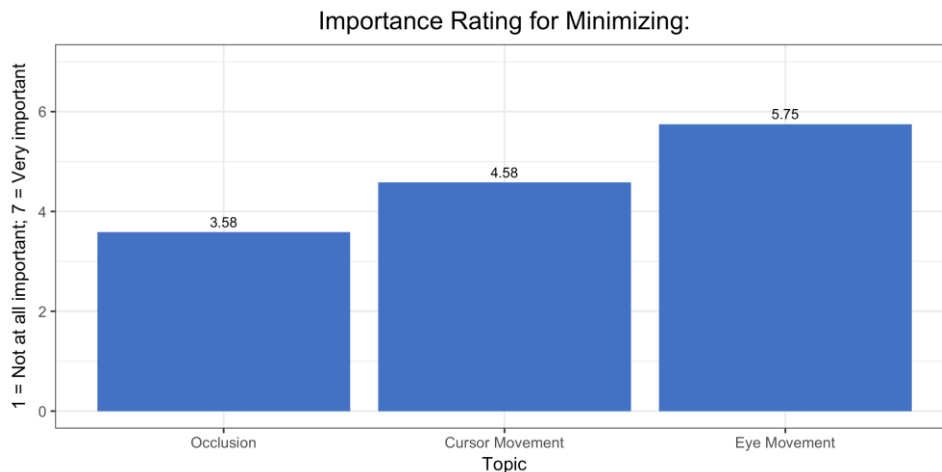

Figure 35. Importance rating of minimizing occlusion, cursor movement, and eye movement.

A common response for rating minimizing occlusion as closer to ‘not important at all’ was that the faceplate would only be occluding information for a short period of time and can be dragged away from important information. A common response for rating minimizing eye movement as closer to ‘very important’ was that having control information close to indications on the mimic reduces ‘eye fatigue’ and minimizes the risk of ‘possible errors.’ One operator commented that he likes to double and triple

check changes made and having this information in closer proximity reduces eye movements. For cursor movement, operators generally commented that minimizing cursor movement is preferred so that inadvertent selection is reduced. Two operators commented explicitly that cursor movement is not an issue so long as eye movements are minimized.

Rating how natural the soft control tasks were. The average rating regarding how natural the soft control evaluation tasks were as, $M = 5.08$, $SD = 1.51$. However, the rationale for operator ratings were considerably variable. Ten operators rated based on comparing how the prototype used (for each design option) compared to the existing control boards rather than based on task itself. One operator commented ‘Don’t feel strongly that behaviors would be different.’ Based on operator feedback collected during data collection, however, one operator commented that the tasks felt more ‘random’ compared to actual operations. Another response from an operator was that they are used to working off a procedure rather than from verbal instructions, which made the tasks less natural. Finally, one operator commented that he thought the tasks were sufficient for testing control options but suggested that future studies could include tasks that require watching for a process value to change over time (e.g., go up) while making control changes. An example he provided was, “Open LV 202 and wait for parameter to go up.”

2.6.2 Design input interview

This section describes the design input interview performed to collect feedback to identify trade-offs within potential design concepts.

2.6.2.1 Summary of Design Input Interview

In addition to the soft controls evaluation, operators also completed an interview comprising questions related to specific aspects of the design philosophy for the BAC/LRS dynamic mimics. Most operators had interacted with the various design concepts in other parts of the study, but a static image of the mimic was available to operators for reference during the interview.

Interview questions were derived to address design considerations concerning the following topics:

1. Dynamic Mimics
2. Color Coding component status and static information like process streams
3. Micro Trends
4. Balances between simplified graphics and representing essential information

2.6.2.1.1 Mimics

The researchers aimed to identify the criteria for when it is appropriate to use mimics to represent the system, what plant systems should be represented as a mimic, and what the challenges in operating system with a mimic (versus other representations). The following questions addressed mimics.

1. Should we use a control mimic display like this one or do you think there is a better approach?
2. What problems do you anticipate (if any) if this type of display is used for other control room systems?
3. Do you think using this control mimic design will work for all systems? (e.g., Turbine Control System [TCS], Chemical Volume Control System [CVCS], etc.)
4. What systems would it work for?
5. What systems won’t it work for?
6. What about a system may cause problems in this design?

2.6.2.1.2 Color Coding

INL researchers produced a design philosophy (Le Blanc et al., 2018) regarding the use of color for a digital system such as the BAC/LRS dynamic mimics. The philosophy endorses a dull screen approach and to only use color where it adds value. How and where color adds value is somewhat controversial. Consequently, the interview included the following questions for use of color:

1. If we color code product streams on some displays, do we need to use the same color codes on all displays, or can we simply show pipes as grey where the product streams aren't mandatory?
2. Can we use all grey colored product streams when color does not help determine effects of flow loops and other equipment?
3. What are the advantages/disadvantages to use colored product streams for every system display to be consistent even when color is not helpful or necessary?
4. What other situations/systems in the plant or the main control room (besides the Liquid rad waste systems) would color-coded product streams make sense or be helpful?
5. When would color coded product streams NOT be helpful?

2.6.2.1.3 Micro Trends

The purpose of micro trends is to provide additional information about a system by displaying a brief history of a process value. However, accompanying all process values with trend lines increases the overall visual complexity of the mimic. As such, trend lines should only be included if the added value outweighs the added complexity. The interview included the following questions on the subject of micro trends:

1. Do the "micro trends" add useful information, or would it be better to simply show the process value instead of showing a limited history and scale?
2. What information are you using when you look at the micro trends?
3. Are you using the trend line or only the process value?
4. When you look at the micro trends, what information do you get?
5. When looking at the micro trends do you expect to get more information if you clicked it?
6. If you clicked it what information would you want to see? (i.e., do you expect to be able to click on the trends to expand the view with more history or more context?)

2.6.2.1.4 Simplified Graphics

Another aspect of the design philosophy is to display all mandatory information at a glance while avoiding unnecessary clutter wherever possible. In order to establish when there is a need to distinguish between various equipment (i.e., valve type) at a glance the interview included the following questions regarding displaying essential information at a glance.

1. Do we need to identify valve type on the mimic beyond showing hand valves and control valves?
2. What are the most important valves types to recognize at a glance?
3. Under what circumstances would seeing the type of valve you are about to operate be helpful?

2.6.3 Method

A total of 21 operators completed the design input interview. The majority of the interviews were conducted one-on-one (i.e., one interviewer and one participant) but a few participants were questioned by multiple interviewers simultaneously. The interviewers used a semi-structured interview to elicit as much open-ended feedback as possible. Responses were coded into 16 categories to facilitate summarizing the responses. If an operator did not provide feedback on a topic, it was reflected as 'No Answer' when coding responses.

2.6.4 Results

Table 14 summarizes the operator responses for the design input interview.

Table 14. Summary of responses for design input interview.

| Question | Disagree | | Agree | | No Answer | | Uncertain | |
|---|----------|-----|-------|------|-----------|-----|-----------|----|
| Dynamic mimics should be used in the radiological waste control room | 0 | 0% | 21 | 100% | 0 | 0% | 0 | 0% |
| There are other systems that can benefit from dynamic mimics | 1 | 5% | 16 | 76% | 4 | 19% | 0 | 0% |
| There are other systems where dynamic mimics would not add value | 4 | 19% | 10 | 48% | 7 | 33% | 0 | 0% |
| Mimics are useful to gain information about flow paths, system configuration, and plant response at a glance | 1 | 5% | 16 | 76% | 4 | 19% | 0 | 0% |
| Dynamic mimics are used for training | 0 | 0% | 2 | 10% | 19 | 90% | 0 | 0% |
| Colored product streams should be used when there is more than one product stream represented on the mimic | 6 | 29% | 13 | 62% | 2 | 9% | 0 | 0% |
| Colored product stream should be used for ALL systems | 14 | 67% | 7 | 33% | 0 | 0% | 0 | 0% |
| Using grey for product streams causes problem(s) | 7 | 33% | 9 | 43% | 5 | 24% | 0 | 0% |
| Micro trends provide useful information | 5 | 24% | 15 | 71% | 1 | 5% | 0 | 0% |
| I and my fellow auxiliary operators expect the micro trends to be clickable | 0 | 0% | 21 | 100% | 0 | 0% | 0 | 0% |
| We expect to see a larger and more detailed version of the trend when clicking on the micro trend | 0 | 0% | 21 | 100% | 0 | 0% | 0 | 0% |
| Control valve types should be identifiable at a glance | 10 | 48% | 10 | 48% | 1 | 4% | 0 | 0% |
| It is enough to identify control valve types from equipment identification number (ID) and/or information presented on the soft control faceplate | 3 | 14% | 3 | 14% | 15 | 72% | 0 | 0% |
| Noun names should be visible at all times for all components | 5 | 24% | 0 | 0% | 16 | 76% | 0 | 0% |
| It is enough to access the noun names via soft control faceplate or by other means (e.g. hover over) | 0 | 0% | 3 | 14% | 17 | 81% | 1 | 5% |
| Centrifugal pumps and/or positive displacement pumps should be identifiable at a glance at all times | 3 | 14% | 10 | 48% | 8 | 38% | 0 | 0% |

2.6.4.1 Mimics

All participants agreed that dynamic mimics should be used for the radiological waste control room. Follow-up explanations varied however. Sixteen of 21 participants (76 percent) agreed that a dynamic mimic such as the INL's design of the evaporator helped them determine information about process paths, system configuration and plant response at a glance. Other explanations included dynamic mimics are beneficial for visual learners as well as tasks that require detailed instructions. Additionally, two participants also mentioned that mimics are used in operator trainings. Seventy-six percent ($n = 16$) of

participants agreed that there are other systems in addition to the radiological waste control room that would benefit from a dynamic mimic approach. Some of the mentioned systems include condensate demineralizer system, resin transfer system, extraction drain system, total dissolve system, concentrate monitor system, and electrical systems. More generic descriptions included systems that encompass various levels of automation and transience were mentioned as good candidates for a dynamic mimic approach. A total of 19 percent ($n=4$) of the participants provided no answer to this question and 5 percent ($n=1$) disagreed that there are other systems that would benefit from a mimic similar to the evaporator. Upon asking the participants if they were aware of any systems in which a mimic approach might not make sense, 48 percent ($n=10$) listed systems such as blow-down demineralizers system, and safety injection pump systems. Systems described as particularly simplified were also listed as criteria that might not be beneficial to design into a mimic format. Further explanations clarified that simplified systems are straightforward in their functionality and control and don't require a visual representation to make a decision. In addition to the 48 percent ($n=10$) that listed systems that might not work as mimics, 19 percent ($n=4$) stated that all systems would benefit from a mimic while 33 percent ($n=7$) provided no answer.

2.6.4.2 Use of Color

Sixty-two percent ($n=15$) of participants agreed that systems with more than one product stream displayed on the mimic should be color coded. A common explanation was that non-color coded systems with multiple product streams are problematic in determining flow paths and flow loops. This can lead to multiple errors such as misdiagnosing an expected system response. Nine percent of participants provided no answer to this question and 29 percent ($n=6$) disagreed that systems with more than one product stream should be color coded. A common response from these participants was that all systems should be color coded, not just multiple product stream systems. When participants were asked directly if all systems should be color coded, 33 percent ($n=7$) agreed while 67 percent ($n=14$) disagreed. Follow-up explanations echoed the mentality that color coding is beneficial for systems with more than one product stream while the lesser percentage thought that all systems should be color coded. In adherence with the use of color design philosophy, one design idea was to color code the products streams in multi-product systems and to use a dull screen (i.e., grey for product streams) for single product systems. However, a potential issue was identified wherein if a multi-product system encompasses steam and color codes it as red, it might cause confusion to use grey for a single product system even if that single product is steam. Forty-three percent ($n=9$) of participants agreed that upon associating a product to a color, it would cause confusion to abandon that color for grey when designing a single product system. These participants explained that they thought it best to remain consistent with color coding throughout all systems. Thirty-three percent ($n=7$) disagreed and stated that it wouldn't be problematic to use grey for single product systems while 24 percent ($n=5$) did not provide an answer.

2.6.4.3 Micro Trends

Seventy-one percent ($n=15$) of participants agreed that the trending line accompanying a process value provides useful information. A common explanation stated that even a brief trend provides more information such as the value is increasing or decreasing, at a glance compared to a lone process value. Twenty-four percent ($n=5$) of participants disagreed that the brief trending line provided useful information and stated that they only need to know the real time process value at a glance. These participants did express their desire for an ability to obtain the trending information elsewhere, they just didn't need it at a glance. All participants agreed ($n=21$) that they expected the micro trends to be clickable and upon clicking the micro trends, they expected to see a larger and more detailed version of the trend. Follow-up explanations varied but many participants explained that these expectations are a result of a system that is currently implemented at their plant called plant information (PI, pronounced "pie") System. PI is a tool that displays "clickable" process values for various equipment and indications surrounding a system. The clickable functionality includes navigation to another screen. The new screen displays additional information pertaining to the process value as well as an expandable trend (i.e., a

timeline of the trend wherein the user can scroll back up to one year). Many participants expressed their desire for PI or a similar tool to be included in all types of mimics and/or control boards to assist them in performing their job.

2.6.4.4 Control Valves

Participants' feedback evenly dissented on the topic of identifying control valves and other equipment at a glance; 48 percent ($n = 10$) agreed and 48 percent ($n = 10$) disagreed that control valves should be identifiable at a glance at all times. The participants that agreed stated the main concern of not displaying valve type at a glance was the probability of misdiagnosing a failure type which could cause a system to shut down. For example, when an air operated valve failure occurs but is misinterpreted as a manual operated valve failure, the proper actions to remedy the situation are also misinterpreted which could cause enough of a delay to where the system is required to shut down in order to resolve the issue. Contrarily, participants that disagreed that valve type need to be distinguished at a glance stated that if anything out of the ordinary happens to any equipment, mandatory protocol elicits operators to investigate what type of equipment is malfunctioning before any corrective actions are taken. That is, as long as the information regarding the type of valve is available elsewhere, there is no need to display the valve type at a glance. A possible location of displaying the valve type is on the controller faceplate which is accessed by clicking on the valve itself. Fourteen percent ($n = 3$) of participants agreed and 14 percent ($n = 3$) disagreed that displaying the valve type on the controller faceplate is sufficient while 72 percent ($n = 15$) of participants provided no feedback regarding this suggestion.

2.6.4.5 Additional Feedback

Questions regarding nouns names were not included in the design input interview, however, many participants offered feedback regarding how the noun names were displayed on the mimic several participants suggested that displaying all noun names at all times would cause unnecessary clutter to the mimic. A suggested compromise included displaying the noun names for the most crucial equipment such as tanks and heaters at a glance while displaying the noun names for the valves/pumps on the associated controller faceplate to reduce the overall clutter.

Another common topic was displaying various pump type at a glance. Forty-eight percent ($n = 10$) of participants agreed that centrifugal pumps and positive displacement pumps should be identifiable at a glance at all times. Many participants explained that knowing the pump type at a glance is essential to operating a system. For example, if an operator mistook a centrifugal pump for a positive displacement pump upon starting the pump, he/she would also misinterpret how much flow the pump was initiating as well as how the fluid was flowing. This mistake could impact essential flow loops and cause delays in the system. Thirty-eight percent of participants provided no feedback on distinguishing pump type at a glance and 14 percent ($n = 3$) of participants deemed it unnecessary. The participants that disagreed that these types of pumps should be distinguished at a glance stated all possible statuses of a pump are initiated by operator control. This means that the status of a pump (i.e., start or stop) cannot be changed without showing the type of pump on the controller which decreases the possibility of the error the other participants described. While this information is generally essential, such information might not be essential at-a-glance.

2.7 2018 July Workshop

2.7.1 Evaluation of Color to Determine Component Status at a Distance

This section describes the micro-task study conducted to determine a senior reactor operator's (SRO) ability to accurately identify component status from a distance utilizing same HSI design concepts as used for the dynamic mimics for the radiological waste control room.

2.7.1.1 Summary of the Evaluation of Color

Two component color schemes (i.e., white/grey and red/green), as well as two mimic overview layouts (i.e., flow path components and banked components) were compared using a total of three operators ($n = 3$), using a performance-based evaluation, and using a series of basic identification tasks (Figure 36). Response times and accuracy were collected as objective measures for human-system performance. Subjective measures of perceived workload and task difficulty were collected using the NASA-RTLX and SEQ (i.e., refer to Table 11).

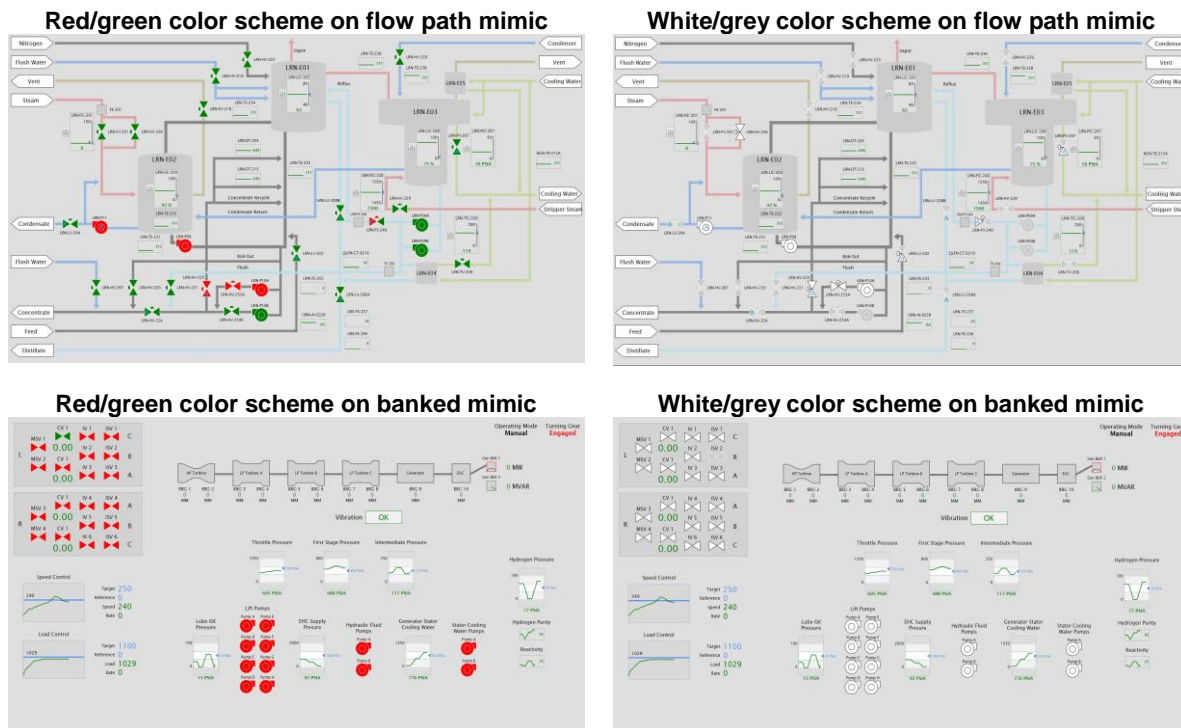

Figure 36. HSI display concepts used in the micro-task evaluation of color from a distance.

The preliminary findings from this evaluation suggest that, at least from a qualitative standpoint, there were little difference in “at-a-distance” viewing performance, perceived workload, or perceived view difficulty between each color scheme, despite the red/green scheme being most preferred by operators. Further investigation with a larger sample size may better uncover whether there is statistical difference in performance characteristics between designs. These preliminary results described here do not provide conclusive evidence of an advantage between either design scheme from a human-system performance standpoint.

2.7.1.2 Method

This section describes the basis for evaluation, participant characteristics, data collection process and the measures used in the evaluation.

2.7.1.2.1 Basis for Evaluation

The HSI with muted product streams with white/grey components provided the most optimal human-system performance in the initial operator workshop that took place in August 2017 (i.e., refer to Section 2.2.1). However, the task used in the previous evaluation simulated a seated workstation wherein the operator would be controlling the system from a seated position located with minimal viewing distance from the HSI display. However, in the main control room, the SRO almost always determines plant status from a distance (e.g., viewing distances of 10-feet or more) based on their designated workstation in the control room. As such, the need to investigate the implications, the red/green and white/grey component color schemes for viewing “at-a-distance”, requires consideration to information the use of color. Additionally, the initial evaluation described in Section 2.2.1 only evaluated HSIs that contained flow path overviews where the components were isolated and dispersed across the mimic layout. Other systems such as TCS may contain a bank (i.e., or group) of valves and pumps where rows and columns of components are adjacent to each other. In essence, the layout of plant components in a larger group may afford ‘emergent properties’ when certain components are in an abnormal or changed state, as opposed to the mimic layout^d. Hence, the need to investigate an operator’s ability to clearly identify component status from a distance in a banked valve overview display was also evaluated.

2.7.1.2.2 Participant Characteristics

A total of three operators ($n = 3$) completed the component status at a distance micro-task study. The average age was ($M = 40.67$, $SD = 1.15$) years with average plant experience of ($M = 11$, $SD = 1$) years. All three operators reported that they have operated the main control room. Operators were asked to rate their experience with technology on a Likert scale (1 = Novice, 7 = Expert). The average rating was ($M = 5.33$, $SD = 0.58$), indicating the operators who completed the soft control evaluation generally believed they were experienced with technology (i.e., computers, smart phones, tablets, etc.).

2.7.1.2.3 Data Collection Process

The study was hosted in the Opensesame (2012) experimental software, which provides a wide range of built-in psychological experimental functions as well as support for Python scripting. This evaluation was performed using one of the Human System Simulation Laboratory (HSSL) bays, presented on the vertical 46-inch display panel (i.e., each panel had a 1920x1080 resolution). Operators used a wireless keyboard/trackpad to interact with the program while standing roughly 11-feet from the display to simulate viewing from the SRO workstation.

To determine the correct dimension of HSI displays while viewing at 11-feet and being placed on the HSSL bay (i.e., using a 46-inch display and 1920 by 1080 resolution), a scaled HSI image of at 75 percent measured at 30.075-inches by 16.95-inches. From this, the design mimic displays set at this size created mimic components of roughly 0.77-inches. Since NUREG-0700 1.3.4-9 suggests that icons should subtend not less than 20 minutes of arc (MA), a maximum distance of roughly 133-inches or ~11-feet away was determined and used for this evaluation.

The overall evaluation task flow was identical for operators (see Figure 37). Essentially, operators were first introduced to the general evaluation to understand the experimental goals and the tasks to be performed. Tasks 1 through 4 were completed sequentially where each task contained a red/green color scheme and a white/gray color scheme in a counterbalanced sequence based on the operators’ identification numbers. An overview of the task with a set of practice trials were provided for each task to

^d Wickens, C. D., Hollands, J. G., Banbury, S., & Parasuraman, R. (2015). *Engineering psychology & human performance*. Psychology Press.

familiarize the operators with the task instructions. A post-task questionnaire was provided to operators using the NASA-RTLX and SEQ. Breaks were given as needed between tasks.

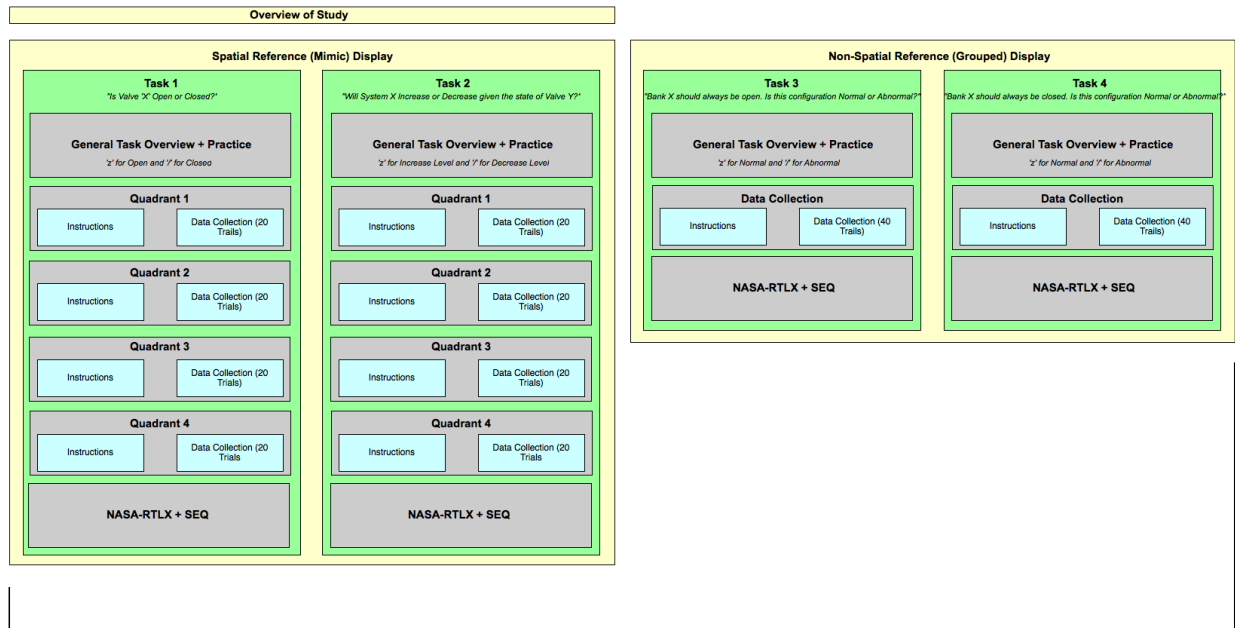

Figure 37. Task flow for the micro-task evaluation of color from a distance.

Task 1 and Task 2, which involved evaluation of the mimic display, each contained a total of 80 experimental trials evenly split by the four spatial quadrants of the screen. For Task 1, operators reported the status of a specific valve at each quadrant (i.e., shown to them by the facilitator) a total of 20 times. The valve was open and closed an event proportion of trials, yet randomly presented. Operators pressed ‘z’ if the valve was open and ‘/’ if the valve was closed. For Task 2, operators were asked if the status of a particular valve would increase or decrease the level in a related sub-system of the evaporator. Operators pressed ‘z’ if the level would increase and ‘/’ if the level would decrease.

Task 3 and Task 4 involved the bank (i.e., grouped) display concept. Since the location of the valve bank was always in the top left, experimental trials were not split up by quadrant. There was a total of 40 trials for each design condition in Tasks 3 and 4. Tasks 3 and 4 were similar in nature; operators had to determine if a certain valve configuration was in an abnormal or normal state. For Task 3, the normal state was based on if all valves in the bank were in an open state. If any one valve was closed, then the configuration would be abnormal. Operators pressed ‘z’ if normal and ‘/’ if abnormal. For Task 4, the normal state was based on if all valves in the bank were in a closed state. If any one valve was open, then the configuration would be abnormal. Operators used a similar response scheme as Task 3 for Task 4. The evaluation concluded with a short preference questionnaire, asking operators for their most and least preferred color scheme. There were freeform response fields available to provide a rationale for their responses.

2.7.1.3 Results

Due to the small sample size (i.e., $n = 3$), raw data is provided as opposed to providing summary results using statistical analysis. Data in green correspond to the red/green (i.e., Design = Colored) design scheme whereas data in gray correspond to the dull design scheme (i.e., Design = Dull). To note, 'subject_2' and 'subject_2b' are one in the same. There was a technical malfunction with Opensesame (2012), which required renaming the participant file to ensure data was not overwritten. The following subsections provide the results for human-system performance, workload, perceived task difficulty, and overall preference.

2.7.1.3.1 Human-System Performance

Line graphs are provided (i.e., Figure 38 through Figure 41) for each task below. Tasks 1 and 2 are broken down by participant and quadrant (i.e., 1-4) to illustrate the raw data. Large nodes indicate that the response was incorrect. Response times are indicated in milliseconds. Trial order is based on the temporal sequence completed by the participant.

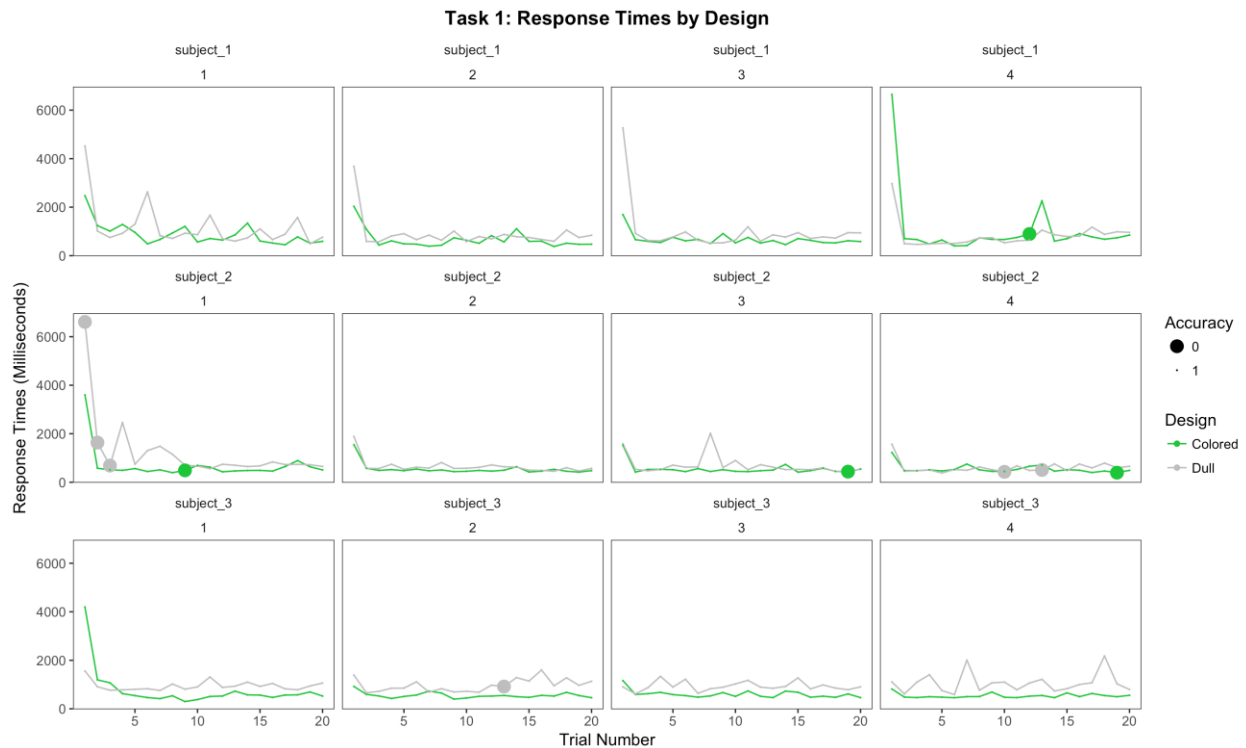

Figure 38. Task 1 response time results for the micro-task evaluation of color from a distance.

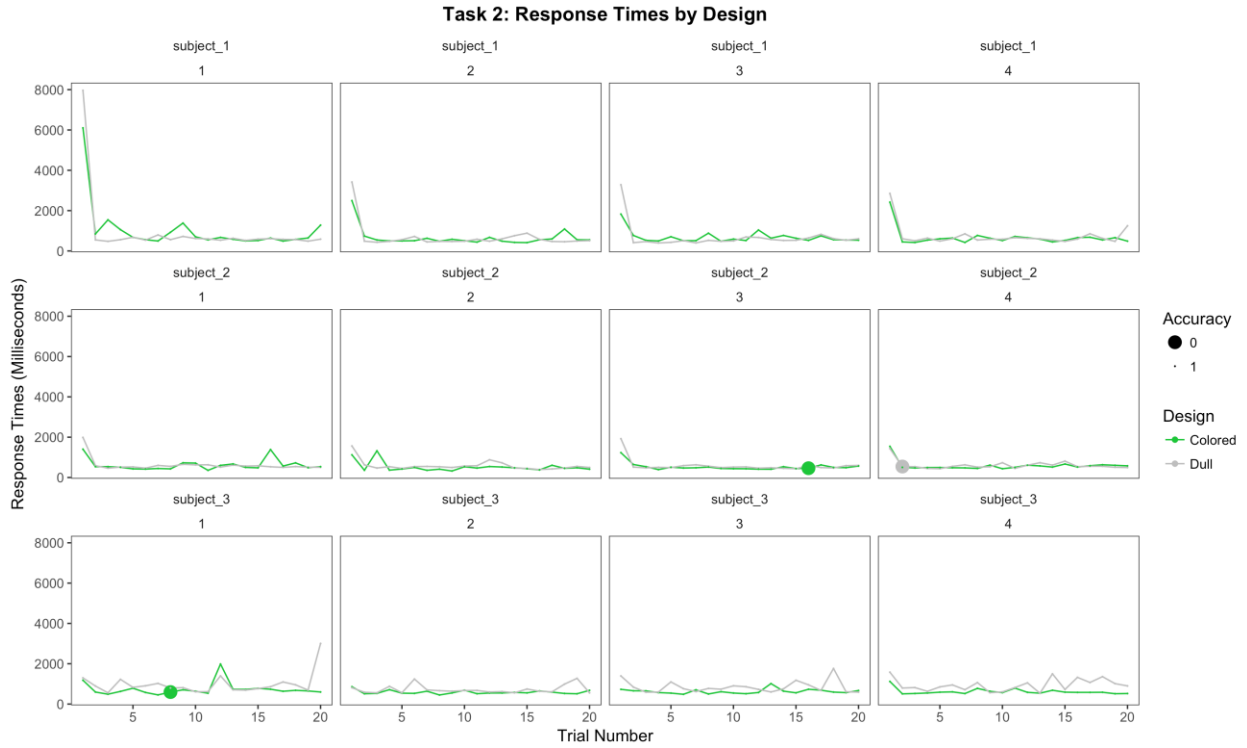

Figure 39. Task 2 response time results for the micro-task evaluation of color from a distance.

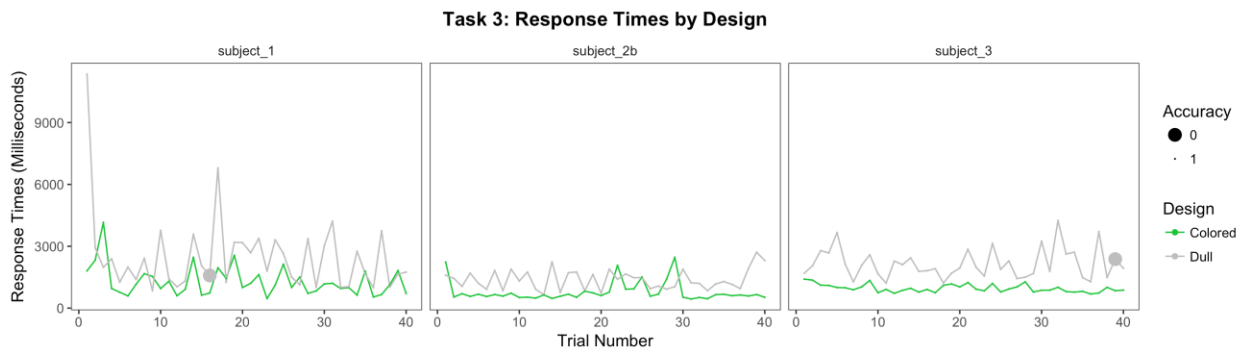

Figure 40. Task 3 response time results for the micro-task evaluation of color from a distance.

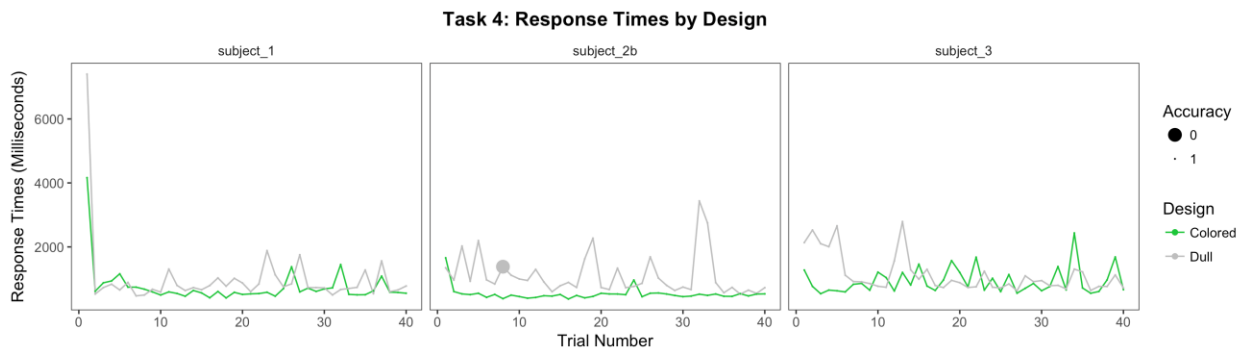

Figure 41. Task 4 response time results for the micro-task evaluation of color from a distance.

2.7.1.3.2 Workload: Tasks 1-4

NASA-RTLX responses are summarized below in Figure 42. The bar charts are broken out by operator (i.e., subject) and Task (i.e., 1-4).



Figure 42. Workload results for Tasks 1-4 for the micro-task evaluation of color from a distance.

2.7.1.3.3 Perceived Task Difficulty: Tasks 1-4

SEQ responses are summarized below in Figure 43. The bar charts are broken out by operator (i.e., subject) and Task (i.e., 1-4).

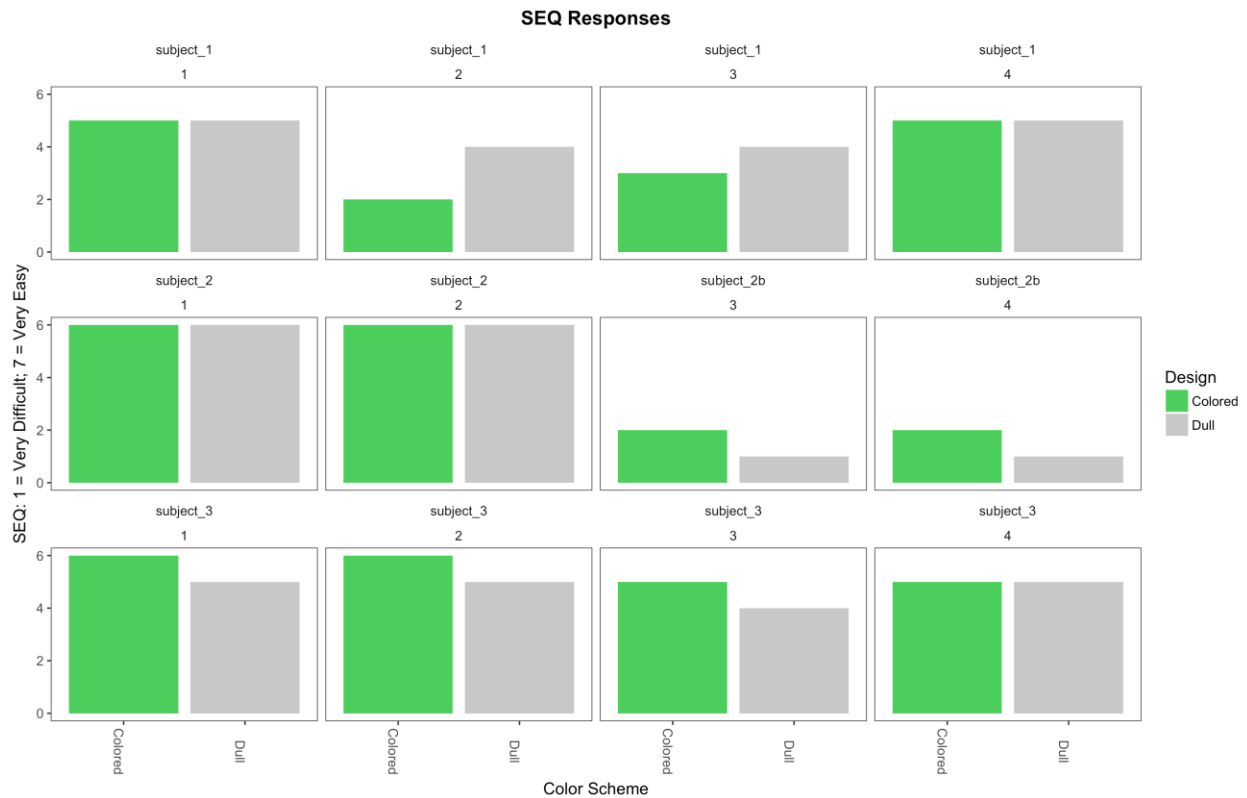

Figure 43. Perceived task difficulty for Tasks 1-4 for the micro-task evaluation of color from a distance.

2.7.1.3.4 Color Preference

All operators preferred the colored (i.e., red/green) scheme most and the dull (i.e., white/gray) scheme least. Two of these operators commented that they preferred red/green because of its familiarity. One operator chose red/green because it was “easier to quickly see [the] difference from a distance.”

2.7.1.3.5 Interpretation of Findings

Collectively, the preliminary findings from this evaluation suggest that, at least from a qualitative standpoint, there were little difference in “at-a-distance” viewing performance, perceived workload, or perceived view difficulty between each color scheme, despite the red/green scheme being most preferred by operators. An interesting finding was the noticeably greater number of errors for operator 2 in Task 1 under the white/gray scheme (Figure 38). While it could be argued that such finding could be attributed to the lower color salience of white/gray, an interesting point is that these errors occurred earlier in the trial sequence and only in Task 1, which came first. An alternative explanation for these errors may be attributed to a lack of familiarity with the scheme. Further investigation with a larger sample size may better uncover whether there is statistical difference in performance characteristics between designs. These preliminary results described here do not provide conclusive evidence of an advantage between either design scheme from a human-system performance standpoint.

2.7.2 Legibility Study

This section describes the Legibility Study performed to support the selection and implementation of required font sizes for the prospective Radiological Waste Control HSIs. A summary of findings is first reported followed by detailed sections regarding this evaluation's method and results.

2.7.2.1 Summary of Legibility Study

NUREG-0700, Rev. 2 provides detailed guidance for font size selection to ensure legibility. Specifically, Guideline 1.3.1-4 (i.e., Character Size for Text Readability) suggests that the minimum font size for provided alphanumeric characters should be a minimum of 16 MA. With this, NUREG-0700 provides a mathematical formula that converts a character's given font height (e.g., in inches) to MA based on the user's viewing distance from the HSI display. While this guideline provides an acceptable basis for designing HSI displays, it cannot be overlooked that such guidance was created when older display technologies (e.g., legacy cathode ray tube monitors) were exclusively available. As such, it is possible that newer display technologies with greater resolutions and minimal flicker may support the use of smaller font sizes while maintaining optimal legibility. One strong motivation for exploring use of font sizes would be to maximum screen space by reducing the number of pixels required to display a given label or value. As such, additional reduction of visual clutter (i.e., NUREG-0700 1.5-8) may be allowed.

This exploratory study evaluated the legibility of three different font sizes for both process values (i.e., herein described as Task 1) and static labels (i.e., herein described as Task 2) when presented on a 27-inch monitor with a 2560 by 1440 resolution positioned at a workstation designed for seated operation. A total of four licensed operators were used in the study. Since it was anticipated that the viewing distance may range from 24-inches to upwards of 30-inches from the monitor (e.g., refer back to Figure 22), a font size of 13-point to 16-point would achieve 16 MA, respectively. Selected font sizes for Task 1 (i.e., for process values) comprised font sizes 10-point, 14-point, and 18-point, respectively. Selected font sizes for Task 2 (i.e., for static labels) comprised font sizes 12-point, 14-point, and 16-point, respectively. Both tasks were presented in the Opensesame experimental software (2012); for each task, operators were presented an image of an HSI display with a varying font size in random order that contained a red box over the value to which they were instructed to report. Operators were instructed to press 'spacebar' once they read the value or label inside the red box. Next, operators reported the value they read by entering it directly via keypress in Task 1 and entered the last numeric digits for a given label in Task 2. A total of 15 trials for each font size (i.e., totaling 45 trials per task) were presented in randomized order for each task. Response time and accuracy were collected for each trial. At the end, operators were asked to record their preference regarding their most and least preferred process value and static label font size.

While no formal statistical tests were conducted given the small sample size ($n = 4$), preliminary results from this study showed noticeably similar response times for each font size. There were no incorrect responses recorded. Further, operators had a mixture of responses regarding their most and least preferred font sizes with process values and static labels. While limited, the results from this exploratory study do not provide any immediate evidence that the application of NUREG-0700 1.3.1-4 no longer applies to modern HSI displays. Further research should be considered using a larger variation of font sizes and a larger sample size for greater statistical power.

2.7.2.2 Method

This study used a total of four licensed operators ($n = 4$) where one operator was collected during the March 2018 workshop and the remaining three operators (i.e., refer to Section 2.7.1.2.2) were collected during the July 2018 workshop. The study was hosted in the Opensesame (2012) experimental software, which provides a wide of built-in psychological experimental functions as well as support for Python scripting. A designated experimental Windows computer was used, connected to a 27-inch (2560 by 1440) monitor. The overall experimental workflow was identical in nature for all participants. Participants first completed a brief practice block to familiarize themselves with both Task 1 and Task 2 instructions; a printed cheat sheet was also available, which contained the task instructions (see Figure 44).

*Perform each task as **QUICKLY** and **ACCURATELY** as possible.*

Task 1: Identify and record the process value highlighted in red.



---- [1] Press Enter/Return when read. [2] Enter '94' in text field.

Task 2: Identify and record the LAST NUMERIC DIGITS from the label highlighted in red (e.g., LIC-HV-328B – record: 328).

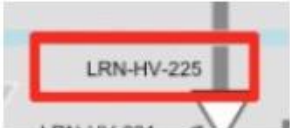

---- [1] Press Enter/Return when read. [2] Enter '225' in text field.

Figure 44. Task instructions for the legibility study.

Participants always completed Task 1, followed by Task 2, and lastly were provided a preference questionnaire built into Opensesame (2012). For Task 1, participants were provided an image of an HSI display with a certain font size for process values. A red box highlighted one of the process values (i.e., note, all process values changed randomly upon each trial). Participants were instructed to read and report the value as quickly and accurately as possible. Participants first pressed ‘spacebar’ once the value was read. Next, the image would disappear, and the participant would enter the value into a text field. Response time was collected, to measure the time from when the image first was presented to the time the participant pressed ‘spacebar.’ Accuracy was collected based on whether the value entered in the subsequent text field was correct. Participants completed a total of 45 trials for Task 1, broken down by 15 trials per font size condition (i.e., 10-point, 14-point, and 18-point) in randomized order.

For Task 2, participants were provided an image of an HSI display with a certain font size for a static label. A red box was also used to highlight one of the static labels. Participants were instructed to read and report the value as quickly and accurately as possible. Participants first pressed ‘spacebar’ once the label was read. Next, the image would disappear, and the participant would enter last numeric characters from the highlighted label into a text field (i.e., note, all labels contained numeric characters at the end of each label string). Response time and accuracy were also collected in a similar fashion as Task 1. Participants completed a total of 45 trials for Task 2, broken down by 15 trials per font size condition (i.e., 12-point, 14-point, and 16-point) in randomized order.

To conclude each experimental session, a preference questionnaire was provided where participants could select, which font size they most and least preferred for both process values and static labels. No open responses were given to save time with other Workshop activities.

Analyses for the legibility study were done descriptively, given the exploratory nature and limited sample size. Response distributions for each font size across both tasks were visualized to understand the overall distribution. Since response time data is typically not normally distributed, the geometric mean for response times was used to describe the response time data across tasks, which is an accepted measure for small-sample human factors/usability ($n < 25$) data (2016). This calculated by log transforming the raw response times, calculating the mean, and then converting the log mean back via exponentiating. To this end, confidence intervals can be calculated using the following mathematical expression:

$$\bar{x}_{log} = t_{(1-\frac{\alpha}{2})} \left(\frac{s_{log}}{\sqrt{n}} \right)$$

Here, t is the critical t-value given a certain alpha (e.g., $\alpha = .05$) value, s is the log transformed standard deviation, and n is the sample size. This study used a Type 1 error rate of ($\alpha = .05$) to report confidence intervals around the geometric mean.

2.7.2.3 Results

Results for the legibility study are provided in this section.

2.7.2.3.1 Task 1: Reading Process Values

No incorrect trials were collected for Task 1. Raw response time data was graphed to visualize the response distributions for each font size (see Figure 45). As shown, the distributions for each font size appeared positively skewed (not normally distributed), illustrating the value of using the geometric mean.

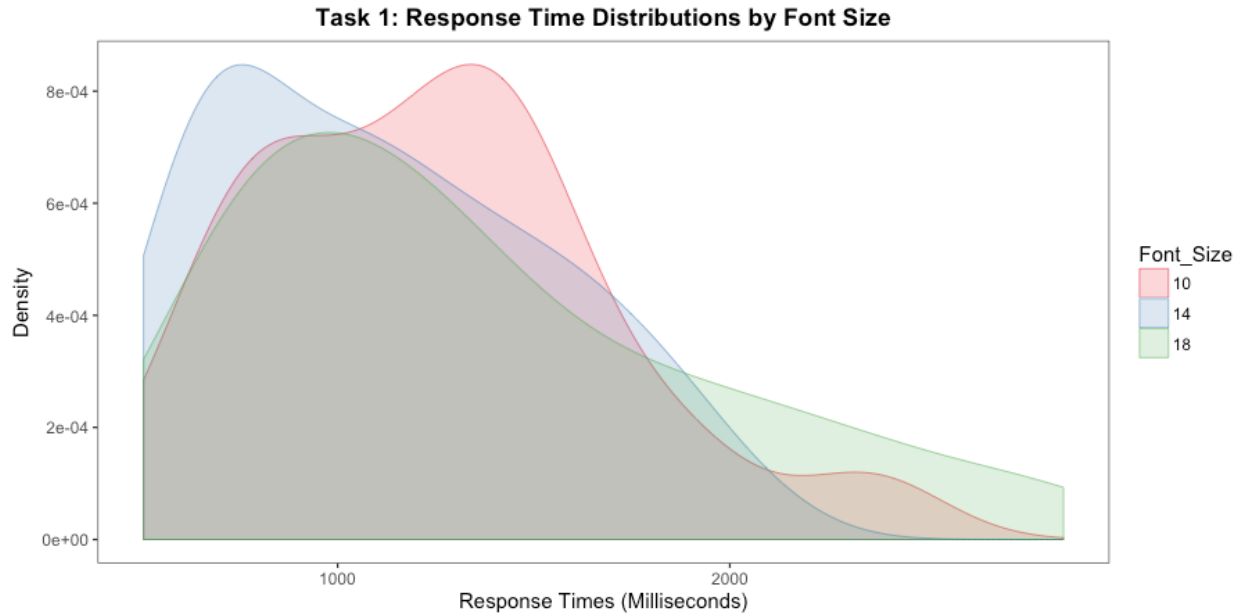

Figure 45. Raw response time distributions for Task 1.

Figure 46 below shows the geometric means of response times for each font size in Task 1. Qualitatively, the mean response times and lower and upper confidence interval limits across font sizes appear noticeably similar. These results suggest no convincing evidence that any one font size (e.g., whether be less or greater than 16 MA) offered better reading performance for process values. Hence, these preliminary results do not support use of any other font size smaller than 16 MA given use of modern monitors available today such as ones using liquid-crystal display technology.

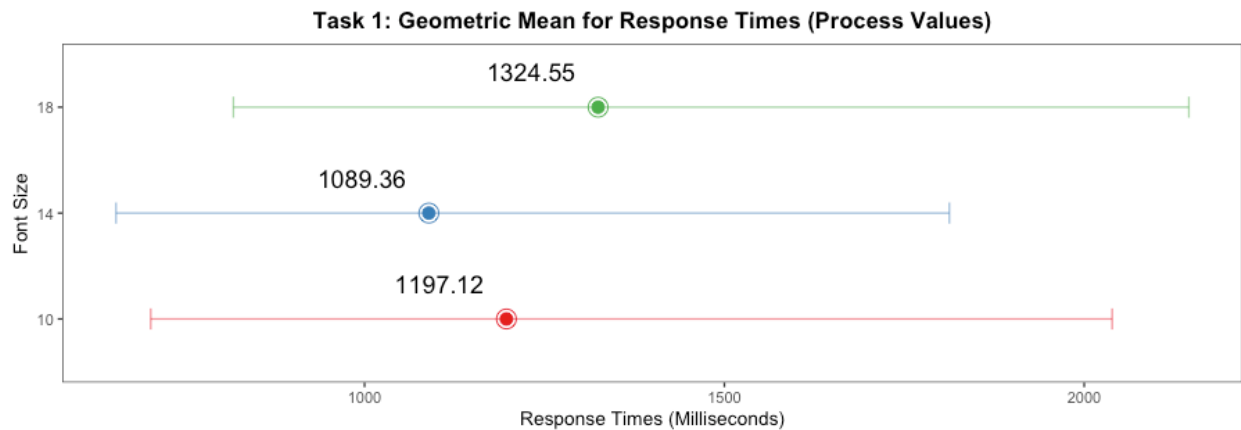

Figure 46. Geometric means of response times for Task 1.

2.7.2.3.2 Task 2: Reading Static Labels

No incorrect trials were collected for Task 2. Raw response time data was graphed to visualize the response distributions for each font size (see Figure 47). As shown, the distributions for each font size appeared positively skewed (not normally distributed), illustrating the value of using the geometric mean.

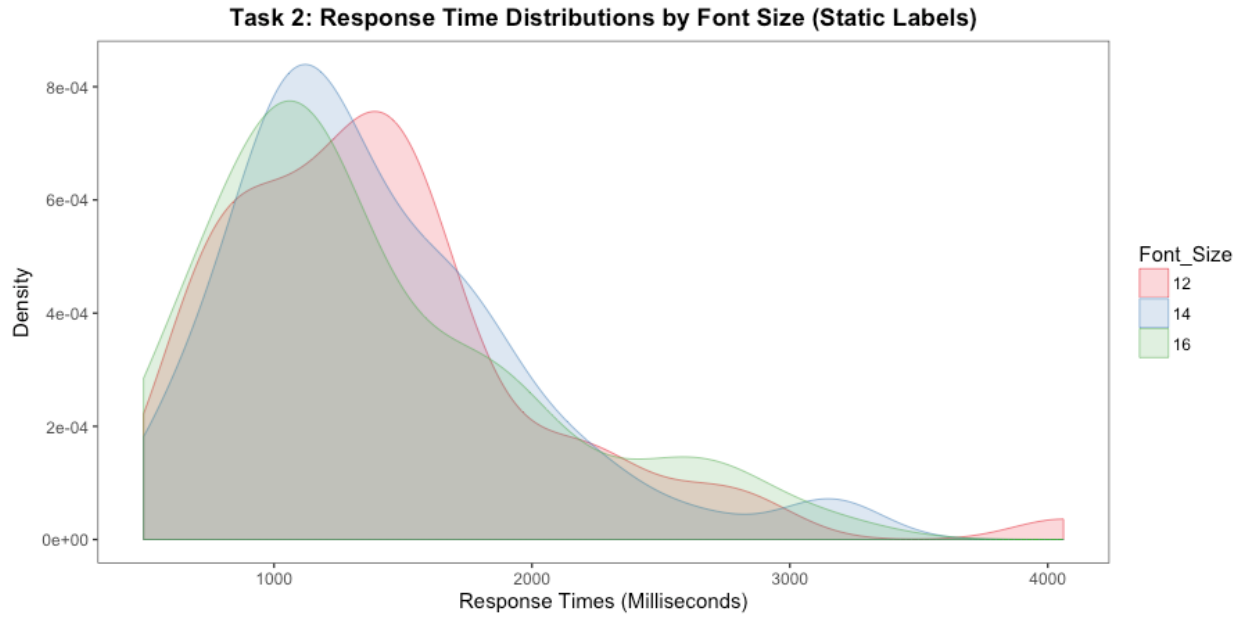

Figure 47. Raw response time distributions for Task 2.

Figure 48 below shows the geometric means of response times for each font size in Task 2. Qualitatively, the mean response times and lower and upper confidence interval limits across font sizes appear noticeably similar. These results suggest no convincing evidence that any one font size (e.g., whether be less or greater than 16 MA) offered better reading performance for static labels. Hence, these preliminary results do not support use of any other font size smaller than 16 MA given use of modern monitors available today such as ones using liquid-crystal display technology.

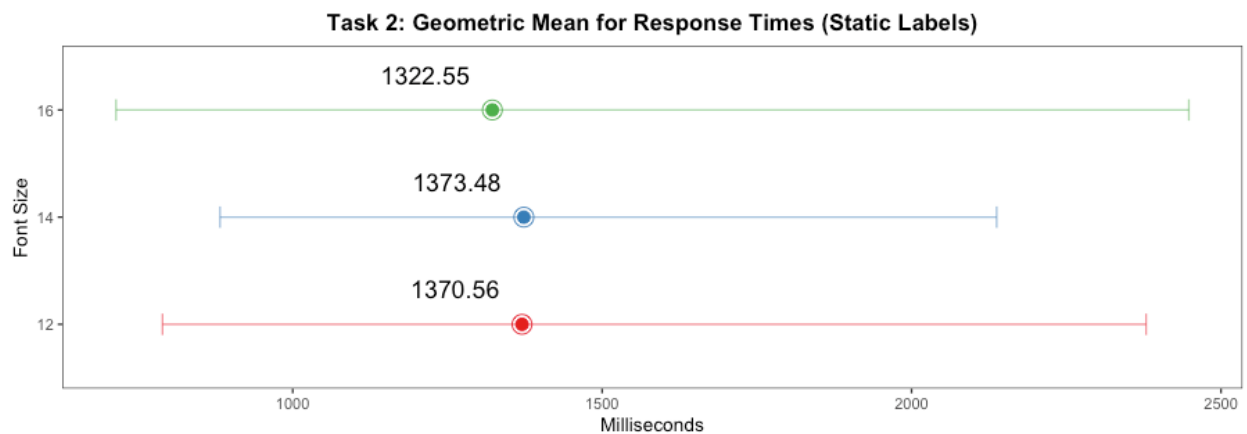

Figure 48. Geometric means of response times for Task 2.

2.7.2.3.3 Operator Font Size Preference for Process Values and Labels

Participant response for most and least preferred font sizes for process values and static labels were tabulated and summarized in Figure 49. Using qualitative inspection, the results across all preference questions showed no noticeable trend towards any one font size regarding most or least preferred; however, one interesting finding worth pointing out was that no participant chose the 18-point font as their most preferred for process values, despite it being the largest font size. It should also be noted that one in three instances, at least one participant did not choose to respond (e.g., showing a total less than 4 for any given question).

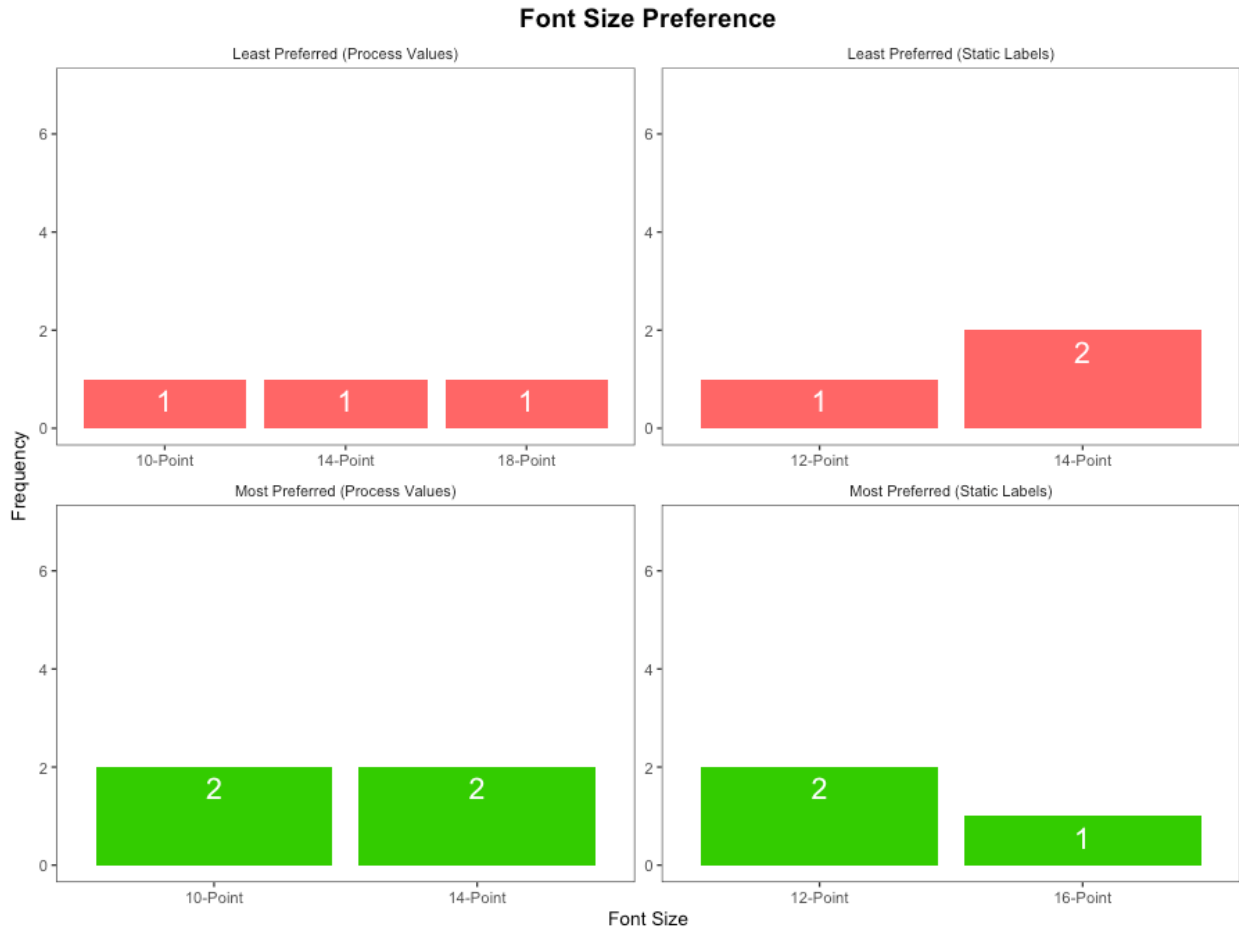

Figure 49. Preference responses for legibility study.

2.7.3 Soft Control Preference Follow-Up Study

This section describes the Soft Control Preference Follow-Up Study performed to validate findings made from the previous Soft Control Evaluation (see Section 2.6.1). A summary of findings is first reported followed by detailed sections regarding this evaluation's method and results.

2.7.3.1 Summary of the Soft Control Preference Follow-Up Study

The previous Soft Control Evaluation revealed little statistical difference in human-system performance, usability, or perceived workload between HSI designs with a designated soft control faceplate region versus a colocated soft control faceplate (see 2.6.1.3). Although, most operators preferred the colocated soft control faceplate design and least preferred the separate soft control display. While these results supported a trend in preference, the lack of a statistical effect in human-system performance suggested further validation using operating experience to inform the selection of an embedded soft control scheme for prospective HSI displays. Specifically, the July 2018 workshop afforded opportunity to collect design input from three licensed operators ($n = 3$) of the main control room.

The Soft Control Preference Follow-Up Study aimed at collecting operating experience from the three licensed main control room operators to: (1) gain insight into their opinions of different soft control schemes, and (2) validate preference findings from the previous Soft Control Evaluation. This activity used a one-on-one interview methodology, with access to various soft control design concepts offered throughout the workshop (e.g., refer back to Figure 32), to query operators' opinions and design feedback for the selection and implementation of an embedded soft control system for prospective HSI displays used throughout the plant.

Results from this study identified a mix of responses regarding the most preferred soft control faceplate scheme. Options A, B, and C each had a single response for most preferred (i.e., each design option integrates the soft control faceplate into a single display). Two of the three operators rated Option D as their least preferred and one operator rated Option C as their least preferred. Common rationale for rating Option D as their least preferred was the greater visual distance from the soft control to its corresponding indication being controlled (e.g., a process value or plant component). Option C was rated as least preferred from one operator because of the potential of occluding important information when the faceplate is open.

While limited in sample size, a key takeaway from this activity was that operators tended to prefer the soft controls integrated into a single display as opposed to using a dedicated display for soft controls (i.e., Options A, B, and C). Operators thought that the separate soft control display could introduce an error prone situation due to the visual distance from operating the soft control system and viewing related information on the separate displays. Selection of a prospective design scheme should follow a risk-based approach in understanding how a prospective design scheme may ensure optimal human-system performance while not introducing new human error modes into operations. Detailed findings from this activity are discussed in Section 2.7.3.3.

2.7.3.2 Method

A total of three licensed main control room operators ($n = 3$) participated in the soft control preference follow-up study. This activity used a one-on-one interview methodology to collect operator preference and design insights to inform the overall HSI design philosophy regarding selection and implementation of soft controls and related topics for the HSI. The interview facilitator performed each interview in a semi-structured format allowing for a freeform dialog on specific design topics concerning the selection of an embedded soft control scheme. Notes from each interview were paraphrased and entered digitally into a spreadsheet. As needed, operators were able to interact with different soft control design schemes from the various demos and prototypes available at the workshop (e.g., see Figure 50 and Figure 51).



Figure 50. Interview facilitator working with an operator in soft control preference study.



Figure 51. Operator working with a soft control scheme in the soft control preference study.

2.7.3.3 Results

Detailed findings from this activity are presented below, which are sub-categorized based on: (1) operator preference for prospective soft control design schemes, and (2) related design input to inform HSI display design.

2.7.3.3.1 Soft Control Design Preference

Figure 52 illustrates general rationales for operators' most and least preferred soft control scheme.



Figure 52. Most and least preferred soft control design schemes from main control room operators.

Most preferred. Options A, B, and C each had a single response for most preferred (i.e., each design option integrates the soft control faceplate into a single display). Collectively, these findings suggest that operators tended to prefer the soft controls integrated into a single display as opposed to using a dedicated display for soft controls (i.e., Options A, B, and C).

Least preferred. Two operators did not prefer Option D (i.e., designated soft control display) due to the increased distance from the controls to the associated components on the displays. A typical response was:

"[Option D requires] too much brain power to figure out what is being controlled." – Operator 3

Option C (i.e., the colocated design) was not preferred by any operator primarily due the risk of occluding important information from the display when the soft control faceplate is opened.

2.7.3.3.2 Additional Design Input

Additional design input was collected as part of identifying ways of enhancing the usability of the prospective soft control scheme and overall HSI design. Notable design input themes were categorized as: (1) selection of component color status, (2) role of highlighting activated controllers and associated components on a mimic display, (3) role of color saliency in HSI design, and (4) selection of specific soft control input formats.

Selection of component color status. Two of three operators made unsolicited suggestions for the use of a red/green color scheme compared to the gray/white scheme when presenting component status indication. One operator commented that the gray/white scheme was difficult to see and would prefer a black/white scheme (e.g., black would denote closed values and stopped pumps) to enhance the saliency of indication status if a red/green scheme was not used. For a more detailed discussion of component color status, see Section 2.7.1.

Highlighting activated controllers and associated components on a mimic display. A mixture of unsolicited responses was collected regarding the format to which highlighted controllers and their associated components on a mimic display are presented. One operator mentioned that he preferred only seeing the associated controller highlighted when selecting its soft control faceplate, rather than seeing the associated components as well. When a controller was tied to multiple components (e.g., see Figure 53), he mentioned that the highlighting was ‘not completely intuitive.’ The operator also mentioned that the display ‘should only highlight what is being controlled.’ Conversely, one other operator mentioned that he preferred having all components highlighted (i.e., like in Figure 53) since it explicitly shows what components are being controlled. From a human factors perspective, having the associated components explicitly highlighted minimized burden on long term memory (i.e., through maximizing ‘knowledge of the world’)⁶. This HFE design principle also supports the use of NUREG-0700 Guideline 7.2.2-3 (i.e., Identification of Loops on Multi-Loop Controllers).

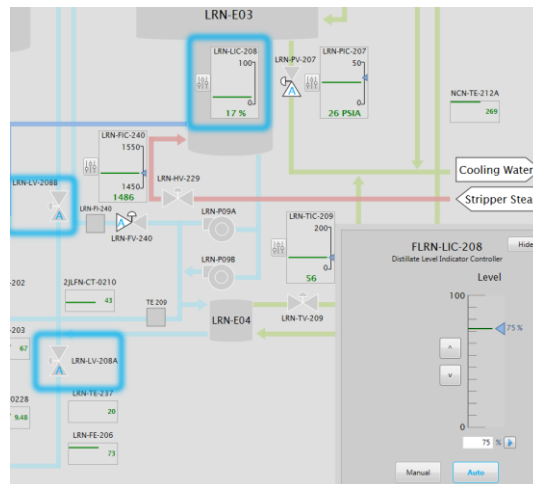

Figure 53. Use of highlighting multiple components tied to a single controller.

Role of color saliency in HSI design. One operator commented that one of the HSI design concepts using a light blue color tone to display a Distillate process path was difficult to see (e.g., see Figure 53 light blue paths). From a human factors perspective, this comment warrants attention to the use of color to

⁶ Wickens, C. D., Gordon, S. E., Liu, Y., & Lee, J. (2003). *An introduction to human factors engineering (2nd Edition)*. Prentice-Hall, Inc., Upper Saddle River, NJ, USA.

ensure critical information is salient. For example, Kovesdi et al. (2018) found that display regions with greater color salience (i.e., as measured by colored difference Delta E 2000), reduced fixation durations, a measure of visual information processing. These results suggest that important information such as the presentation of process paths on a mimic display should use a salient selection of color from its given display background. Figure 54 and Figure 55 show Delta E 2000 and luminance contrast ratios for the color palette used for the radiological waste control room HSI displays, respectively. Higher values for both calculations indicate greater saliency. As indicated, the light blue (i.e., #BCDEEA) has a low Delta E 2000 and contrast ratio value indicating low saliency.

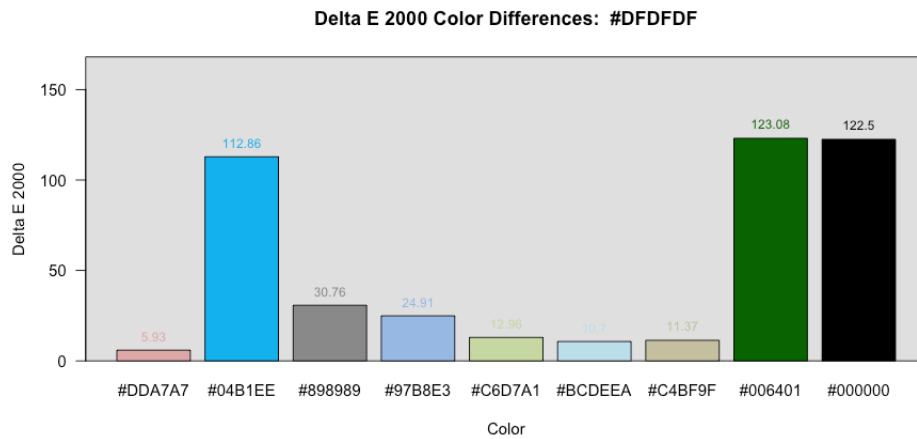

Figure 54. Delta E 2000 values for the radiological waste control room HSI display color palette.

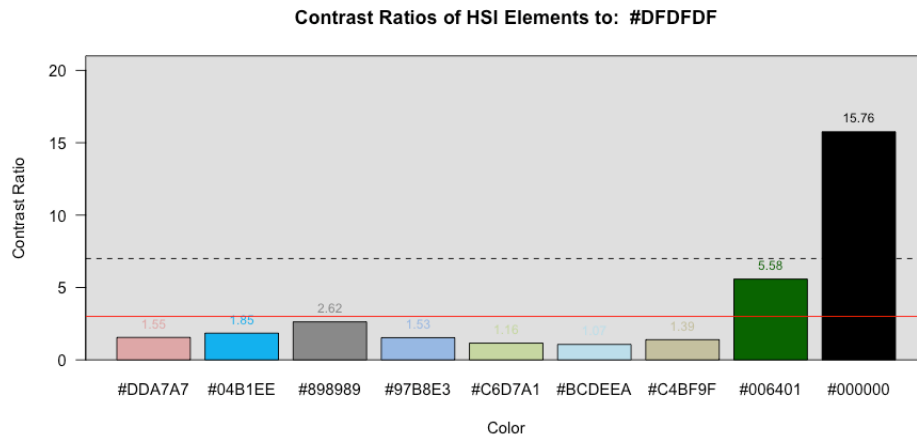

Figure 55. Luminance contrast values for the radiological waste control room HSI display color palette.

Selection of specific soft control input formats. One operator mentioned that the variety of soft control inputs such as the numeric entry field, vertical slider, and discrete adjustment buttons were appropriate formats for a soft control system. Specifically, the discrete adjustment buttons were most familiar to this operator based on prior experience with other HSIs. He also requested having two separate types of discrete adjustment controls (e.g., an arrow and double arrow) to allow for both +/- 1 percent and +/- 2 percent adjustments.

2.7.4 Ergonomics Evaluation for Reach Requirements

This section describes the ergonomics evaluation for reach requirements performed to inform the placement of HSI displays with embedded soft controls with touch input.

2.7.4.1 Summary of the Ergonomics Evaluation for Reach Requirements

There were two primary ergonomics evaluation activities completed concerning the reach requirements with positioning soft controls embedded within the HSI displays on the angled section of the control boards in the main control room. The first activity comprised an ergonomics evaluation of operator functional reach envelopes, using anthropometric data of general population stereotypes, when interacting with controls at the angled section. The results from this activity identified that a 5th Percentile Female would not be able to use functional reach to interact with soft controls positioned on the angled section; in an extended reach while leaning, a 5th Percentile Female would be able to reach these controls. The second activity regarded a follow-up interview with operators to collect their feedback and preference of the location of HSI displays that have embedded soft controls. Alternative designs were provided such as positioning the HSI displays on the apron section. Findings from the interview suggested that operators prefer the placement of HSI displays that have embedded soft controls on the angled section over the apron section. Further, HSI overview displays located on the vertical section should not be placed in front of safety-related controls on the apron section to mitigate inadvertent activation. Alternative input devices for individuals who are unable to comfortably reach soft controls at the angled section was also acceptable for operators.

2.7.4.2 Method

This section describes the methodology used for the initial ergonomics evaluation using anthropometric data to inform reach requirements, as well as the follow-on ergonomics interview portion of the overall evaluation. The following sub-sections are broken up as: (1) control room console diagram used in the analysis, (2) selected HFE guidance for reach ergonomics, (3) assumptions and caveats with interpretation of the built anthropometric models, and (4) ergonomics interview questions.

2.7.4.2.1 Control Board Console Diagram

Main control room console dimensions were recorded from a provided EC drawing. Figure 56 provides a dimensionally correct control board schematic from this document used in the ergonomics evaluation. An illustration of primary sections concerning this evaluation are superimposed.

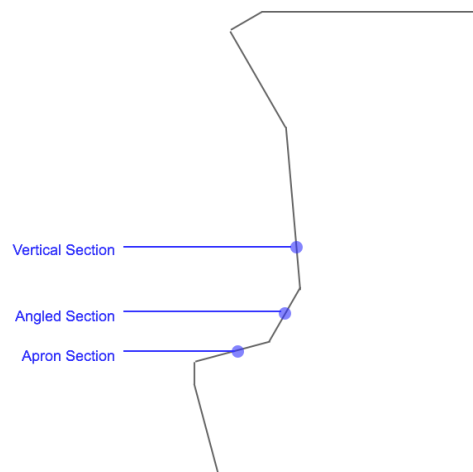

Figure 56. Control board console used for the anthropometric reach model.

2.7.4.2.2 Selected HFE Guidance for Reach Ergonomics

Reach requirements for stand-up consoles pertain to NUREG-0700 guideline 11.1.1-2 (i.e., refer to Figure 11.1 in NUREG-0700). From Table 11.1 in NUREG-0700, reach envelopes were created using the functional reach measurements (i.e., 5th Percentile Female - 25.2 inches & 95th Percentile Male - 35.0 inches) with the shoulder height measurements (i.e., 5th Percentile Female – 48.4 inches & 95th Percentile Male – 60.8 inches) similar to as shown in Figure 11.1 in NUREG-0700. Table 11.1 is provided in Appendix A: Table 11.1 of NUREG-0700 for reference. These analyses were done in R.

It should be noticed, however, that NUREG-0700 does not provide descriptive measures such as mean and standard deviation to describe the distribution characteristics of the anthropometric data used for Table 11.1. Further, the data used from NUREG-0700 comprises of aggregated data from MIL-STD-1472D Table 13 for the male and female populations (see Appendix B: Table 13 of MIL-STD-1472D). In either case, means and standard deviations are not provided. Thus, to make estimates of the proportion of males and females who are unable to reach the soft controls located on the proposed HSI displays located on the angled section, this analysis used available anthropometric data collected largely from United States (U.S.) Air Force and Army men and women provided in Table 10.2 of Wickens et al. (2003). Appendix C: Table 10.2 and Figure 10.3 from Wickens et al. (2003) provides this data for reference (i.e., data from 1a). A comparison of the anthropometric data for male and female populations from NUREG-0700, MIL-STD-1472D, and Wickens et al. (2003) are listed in Table 15 and

Table 16 below (i.e., for functional reach and shoulder height).

Table 15. Comparison of Anthropometric Data for Functional Reach from Selected HFE Resources

| NUREG-0700 | | | | |
|-----------------------|----------------|--------------------|------------------|----------------------|
| Percentile | Male | Women | | |
| 5th | n/a | 25.2 | | |
| 95th | 35.0 | n/a | | |
| MIL-STD-1472D | | | | |
| Percentile | Ground Troop | Aviators | Women | |
| 5th | 28.6 | 28.8 | 25.2 | |
| 95th | 35.8 | 34.3 | 31.7 | |
| Wickens et al. (2003) | | | | |
| Percentile | U.S. Army Men* | U.S. Air Force Men | U.S. Army Women* | U.S. Air Force Women |
| Mean | 32.5 | 31.2 | 29.2 | 28.1 |
| SD | 1.9 | 2.2 | 1.5 | 1.7 |
| 5th (Est) | 29.4 | 27.6 | 26.7 | 25.3 |
| 95th (Est) | 35.6 | 34.8 | 31.7 | 30.9 |

Table 16. Comparison of Anthropometric Data for Shoulder Height from Selected HFE Resources

| NUREG-0700 | | | | |
|-----------------------|----------------|--------------------|------------------|----------------------|
| Percentile | Male | Women | | |
| 5th | n/a | 48.4 | | |
| 95th | 60.8 | n/a | | |
| MIL-STD-1472D | | | | |
| Percentile | Ground Troop | Aviators | Women | |
| 5th | 52.6 | 52.5 | 48.4 | |
| 95th | 60.7 | 60.9 | 56.6 | |
| Wickens et al. (2003) | | | | |
| Percentile | U.S. Army Men* | U.S. Air Force Men | U.S. Army Women* | U.S. Air Force Women |
| Mean | 56.6 | 57.6 | 51.9 | 56.3 |
| SD | 2.4 | 3.1 | 2.7 | 2.6 |
| 5th (Est) | 52.7 | 52.5 | 47.5 | 52.0 |
| 95th (Est) | 60.6 | 62.7 | 56.3 | 60.6 |

Since data across the three sources were similar, subsequent reach estimates across male and female populations could be completed using the means and standard deviations from Wickens et al. (2003). Specifically, data from the U.S. Army were used for estimates of reach requirements for both men and women. Estimates were completed using simulation in 'R' based on normal probability distributions. Specifically, the mean and standard deviations from the provided U.S. Army men and women were used to create a simulated dataset of 1,000,000 randomly sampled shoulder height and functional reach measurements from a normal distribution. This simulated dataset was then used to create an estimated proportion of males and females who are unable to reach the furthest HSI control from the angle section. The furthest control was selected as a conservative estimate.

Finally, extended reach while leaning forward (12-degrees) was evaluated for the 5th Percentile Female population as a comparison of worst-case accessibility of soft controls on an HSI display located on the angle section of the control board. Anthropometric data was used from Table 11.1 in NUREG-0700 and MIL-STD-1472D Table 13 for estimates.

2.7.4.2.1 Caveats and Assumptions of the Anthropometric Model

It should be emphasized that placeholder displays from the model are not from any specific hardware model. It's possible that the dimensions of the selected HSI displays being used might project out more from the board than what is shown here. Additional considerations worth emphasizing are that the second analysis (i.e., estimating proportions who cannot reach) made the following assumptions:

- Data from Wickens et al. (2003), comprising descriptive statistics of U.S. Army and U.S. Air Force personnel, is comparable to U.S. nuclear power plant operators.
- A normal distribution can be assumed for male and female populations.

If any of these assumptions are not true, then the results from this analysis are not credible. It should be also noted that Wickens et al. (2003) indeed cautions the strict extrapolation of specialized populations like the U.S. Army or U.S. Air Force when conducting ergonomic evaluations outside of this population-base. As such, any design decisions should be aware of potential differences between populations.

2.7.4.2.1 Ergonomics Interview Questions

To support discussion with operators, a 3-D model of the end-state control room was shared prior to engaging in the semi-structured interview. The 3-D model was developed using the Trimble SketchUp software package and faithfully represented the actual dimensions of the control board (see Figure 57). An anthropometrically correct mannequin of a 5th Percentile Female was added to illustrate reaching gaps.

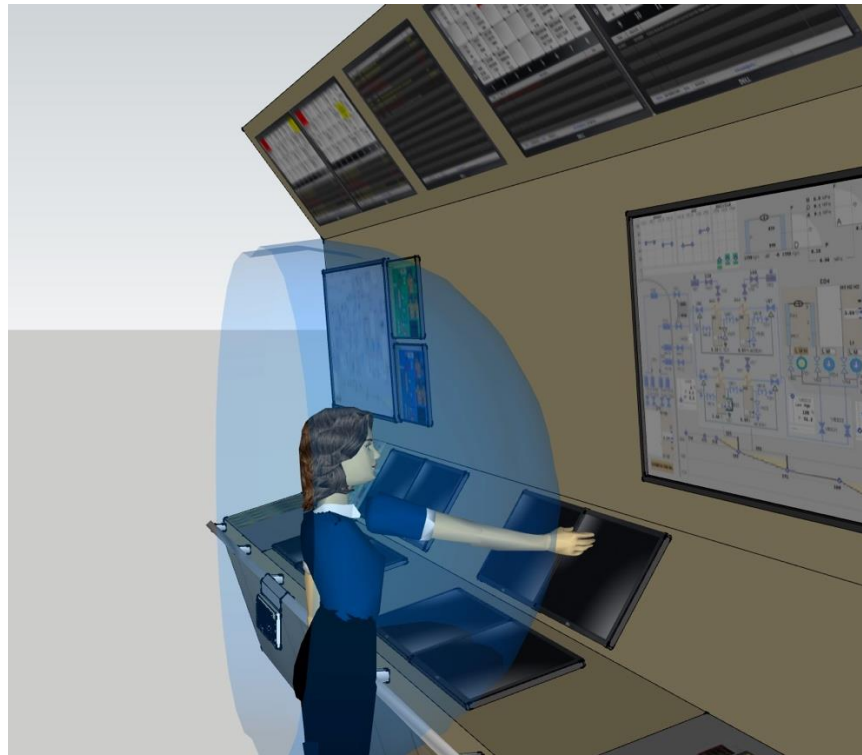

Figure 57. 3-D model snippet used to support the ergonomics interview.

The following questions were used to prompt discussion in a semi-structured fashion.

1. If there were HSI displays presented on the angled section with soft controls (i.e., operated via touch), would the reach requirements for you be acceptable for INFREQUENT ACTIONS?
2. If there were HSI displays presented on the angled section with soft controls (i.e., operated via touch), would the reach requirements for you be acceptable for FREQUENT ACTIONS?
3. Do you see any potential human error traps having HSI displays with soft controls (i.e., operated via touch) on the angled section?
4. Do you see any potential human error traps having (analog) safety-related controls on the angled section?
5. If there were HSI displays presented only the apron section, do you foresee any potential concerns with frequent monitoring with these displays in such a location?
6. Are there other alternatives that you can think of, that weren't previously covered, to address this ergonomics concern?
7. If the HSI displays presented on the vertical section (i.e., where the overviews are) had controls embedded, would the reach requirements be acceptable to you for INFREQUENT ACTIONS?
8. If the HSI displays presented on the vertical section (i.e., where the overviews are) had controls embedded, would the reach requirements be acceptable to you for FREQUENT ACTIONS?
9. Are there alternative to touch interaction for HSI controls on the vertical section that would be acceptable (e.g., mouse or trackpad?)

The preliminary report was shared with operators as an additional resource to prompt discussion.

2.7.4.3 Results

Results from the anthropometric model and interview are discussed in separate sections here.

2.7.4.3.1 Anthropometric Model Results and Recommendations

Reach envelopes are summarized in Figure 58.

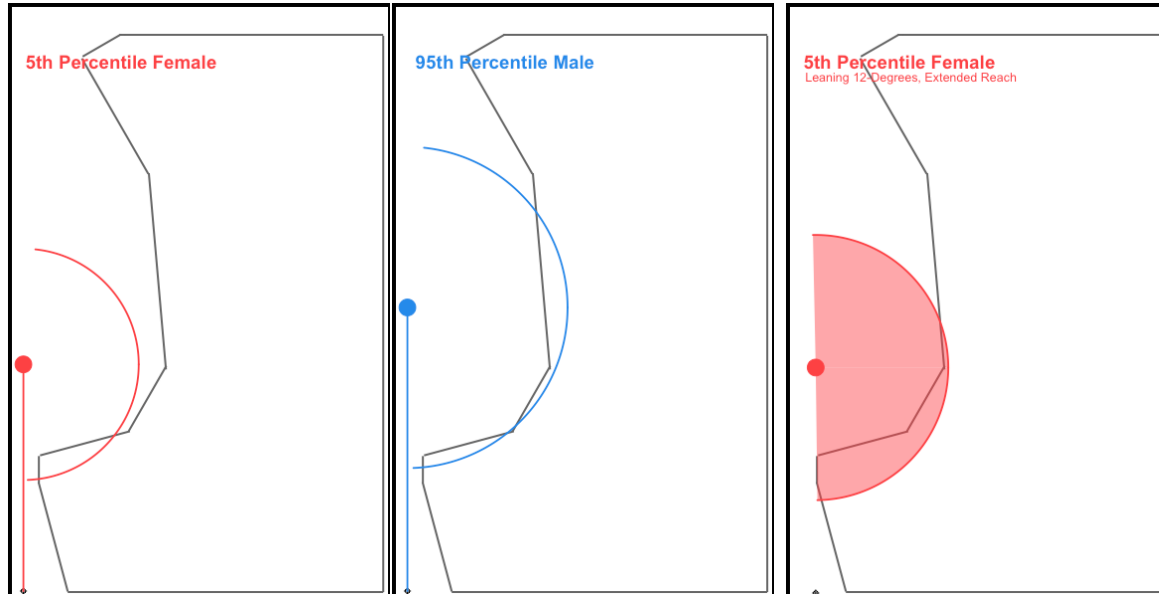

Figure 58. Reach envelopes for the 5th Percentile Female and 95th Percentile Male.

The left to illustrations of Figure 58 represent reach requirements for the 5th Percentile Female and 95th Percentile Male. As shown, the displays on the angle would be within the reach envelope for a 95th percentile male but outside the reach envelope for a 5th percentile female in both cases. As a result, the proposed design would violate Guideline 11.1.1-2, accounting for functional reach. However, results from the extend reach evaluation (rightmost illustration of Figure 58) show that a 5th Percentile Female is capable of reaching the angle section of Board 6 using extended research (i.e., extended the shoulder forward as far as possible) and leaning forward (e.g., bending over) 12-degrees over the guard rail. As such, even worst-case reach requirements can be met with workarounds; though, this strategy is not ergonomically optimal.

Estimated proportions of males and females unable to reach the further possible soft control located on the HSI display on the angled section using only functional reach are presented below in Figure 59. Based on this simulation, nearly 99 percent of females and 45 percent of males would not be able to reach the furthest set of HSI display soft controls located on the angle section of Board 6 when accounting for functional reach.

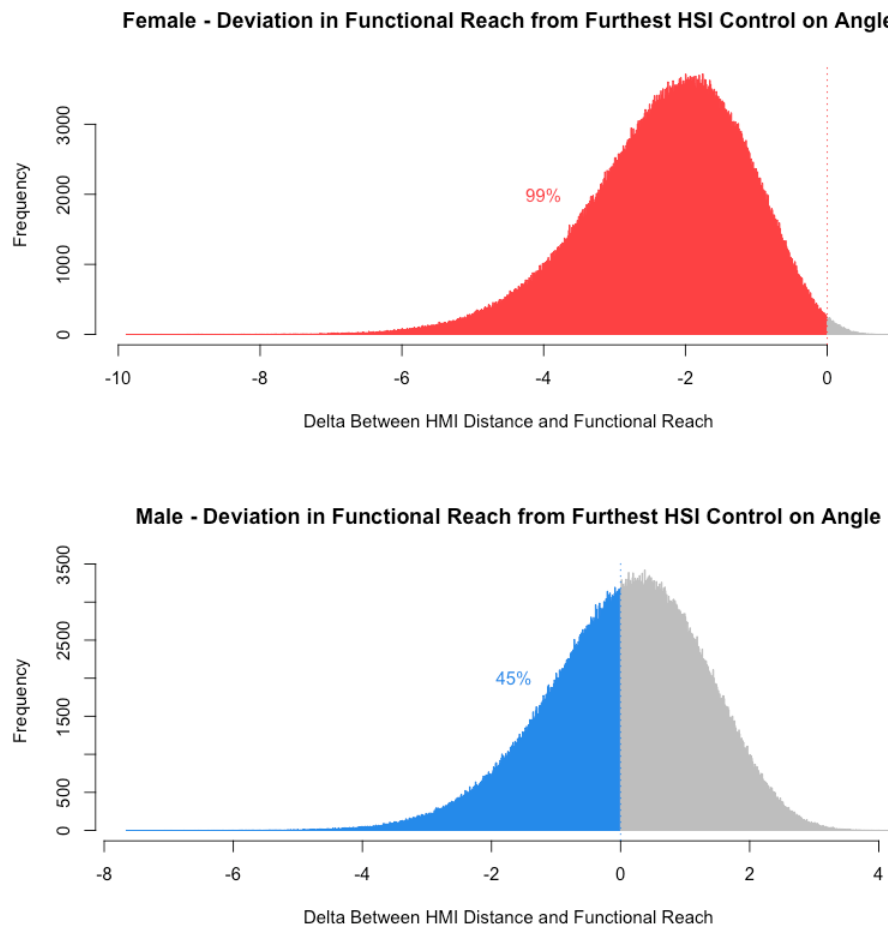

Figure 59. Estimated proportion of female and male operators unable to reach furthest HSI control using functional reach.

Given the assumptions and interpretation of the data, the evaluation of NUREG-0700 Guideline 11.1.1-2 is unmet when standing at the guard rail. Follow-up estimates of male and female operators who would not be able to reach the furthest control on the HSI display at the angled section suggests that around 99 percent of females and 45 percent of males would not be able to maintain contact of the furthest controls on this HSI display using functional reach when at the guard rail. To note, these estimates do not consider maximum reach (e.g., extending one's shoulder to increase reach span) or other workarounds (e.g., bending over, leaning, etc.) to support the interpretation of NUREG-0700 Guideline 11.1.1-2. Follow-on analysis using extended reach while leaning forward 12-degrees for the 5th Percentile Female (worst-case) suggests that soft controls presented on the angled section would be accessible using such workarounds, though not an ergonomically-optimal strategy.

Recommendations. The following recommendations are provided from this preliminary evaluation:

- HSI displays that require long-term monitoring should not be positioned on the apron section. The angled section offers a better viewing angle.
- For HSI displays on the angled section that are used for frequent control actions, consider a secondary input device for control (e.g., a mouse) for users who are unable to reach.

- Moving analog controls from the apron to the angle section to ensure HSI displays can fit on either the apron or vertical panels should be weighted via cost-benefit (e.g., does the benefit of ensuring all potential users can use functional reach outweigh the potential costs of moving analog controls such as those associated with safety-critical functions?).
- Consider a trade-off evaluation with operators to explore possible design options.

2.7.4.3.2 Ergonomics Interview Results and Recommendations

When operators were asked whether having soft controls positioned on the angled section of the control board were acceptable for either infrequent or frequent actions (i.e., Questions 1 and 2), operators generally agreed that such location would be acceptable. Operators explained that potential reach concerns are currently mitigated by providing an alternative input device, a trackball device, to individuals who may not be able to interact via touch input. Operators did not believe there would be a potential human error trap with having the soft controls positioned on the angled section (i.e., Question 3); operators mentioned that there was no concern of inadvertent activation of controls from at the apron or angled sections (i.e., Question 4) and general reach requirements were acceptable at this location (e.g., “Way better than at the vertical section.”).

When asked if there were any potential concerns with frequent monitoring if having the HSI displays on the apron section (i.e., Question 5), operators commented that such position would create viewing angle concerns. To this end, operators expressed preference of having the HSI displays with embedded soft controls on the angled section over the apron section to support visibility of displays from a distance. Operators did not provide any location alternatives beyond the angled section (i.e., Question 6). When operators were asked whether having embedded soft controls on the overview displays at the vertical section such as with TCS or Feedwater (i.e., Questions 7 and 8), operators mentioned that such functionality would pose concern if they were positioned over remaining analog safety-related controls (e.g., requiring the operator to reach over these controls). Lastly, operators commented that there currently are alternative input devices used for interactions at the vertical section (i.e., trackpad).

Recommendations. Collectively, the findings from this interview suggest:

1. Positioning non-overview HSI displays on the angled section is acceptable to operators and preferred over positioning them on the apron section.
2. If large overview displays enable touch input, their location on the vertical panel of the control boards should not be placed directly over safety-related controls to mitigate risk of inadvertent activation.
3. As needed, the use of a trackpad, or alternative input device, may serve as an alternative for individuals who are unable to reach soft controls provided on the HSI displays at the angled section.

3. DESIGN PHILOSOPHY

Section 3 provides detailed guidance for the design philosophy of selection HSI design topics, including: Information Architecture, Overviews, Use of Mimics, Use of Color, HSI Navigation, Controls, Integrated Displays, Use of Graphics, and Alarms.

3.1 General Design Philosophy

The following section summarizes insights from existing design concepts, approaches and philosophies that describe principles to guide all aspects of the design philosophy developed through this INL effort.

1. Provide Functional Information. The approaches listed above generally advocate displaying functional information rather than simply displaying physical information.

2. Facilitate Skill and Rule Based Behavior and Provide Graphics that Support Knowledge Based Behavior. One of the principles of EID is to present information in a way that is compatible with the strengths and weaknesses of human information processing. This is typically accomplished in EID by applying Rasmussen's Skills, Rules and Knowledge taxonomy (Rasmussen et al., 1994). The IRD approach also emphasizes the importance of supporting skill and rule-based behavior.

3. Use Trend Displays where applicable. Trend displays allow an operator to quickly determine how a parameter is changing over time. When changes over time are important for the operator to control or monitor the plant, displaying parameters in trend plots rather than simply displaying the current value reduces the amount of cognitive processing an operator must perform. Trend plots enable the operator to see how the parameters are changing over time rather than relying on the operator's limited memory capacity to recall where parameter values were in the past. In addition, applying the principles laid out in IRD mini-trends such as shading of alarm set points on the plot also allows operators to quickly detect how far a parameter is away from set points and limits. Using these principles, operators do not have to remember what the set points are or calculate how far the current value is from those set points, thus freeing up cognitive resources for other important tasks.

4. Facilitate Perceptual Processing of Information Where Possible. IRD, EID and HPHMI approaches highlight the need to support perceptual processing of information. IRD's analog normalized mini trends allow operators to visually perceive when a parameter is out of range and how far it is away from alarm and trip set points. The operator does not need remember all these details, he can simply see them on the screen. Similarly, grouping functionally related information and scaling trends to line up during normal operation so deviations can be easily perceived may reduce the operator's workload.

5. Minimize Use of Saturated Color. The approaches summarized above tend to emphasize reserving saturated color for highlighting abnormal conditions, while using lower contrast greys and blues for static display elements and dynamic elements that are within normal operating conditions.

6. Improve Abstraction and Data Aggregation. A design principle common among the above approaches is avoiding presenting plant parameter and equipment status on a component-by-component and system-by-system level and instead supplying operator information based on the functional response required by plant conditions and operational goals.

7. Provide Diagnostic Guidance and Planning Support. Integrating lower level information for purposes of determining the existing plant state and to predict future states is a source of operator workload. To reduce operator effort, displays can offer hypotheses, suggested recovery actions and uncertainty information to aid operator decision making.

3.2 Ensuring an Effective End-state in a Phased Approach

One risk in embarking on a phased upgrade rather than a full-scale, all in-one modernization is the phased approach may result in a piecemeal look and feel in the control room even in the presence of an overarching design philosophy. This document is intended to maximize the likelihood that the phased upgrades will result in a consistent design for the HSI features across all systems.

However, a consistent design philosophy is only one consideration is ensuring an effective end state. Another important consideration is how to maximize the effectiveness of information abstraction and aggregation even when some systems may not yet be upgraded. The authors recommended identifying information that is relevant to high level plant overview and for integrated system overview and ensuring that process parameters and component status for all relevant equipment be brought into the distributed control system (DCS) regardless of whether it will be upgraded into the current or in future phases of the control system upgrade. This ensures that information needed to provide effective plant status and system status is available to the system that is used to present information through the HSI. Initially, this may be accomplished by providing information pulled from a plant computer or other system that is used to store and process plant information. As each phase is complete, relevant information will be pulled directly from the DCS as it is made available.

This approach enables the use of effective overview and integrated displays even when information needed is not yet part of an upgraded system and ensures that there will be no need for redesign of individual system displays or a plant overviews when the plant upgrades reach the final end state.

3.3 Information Architecture

One aspect of system design that may heavily contribute to HSI design is information architecture. *“Information architecture (IA) focuses on organizing, structuring, and labeling content in an effective and sustainable way. The goal is to help users find information and complete tasks. To do this, you need to understand how the pieces fit together to create the larger picture, how items relate to each other within the system. (www.usability.gov/what-and-why/information-architecture.html)”*

3.3.1 Design Philosophy

This section provides recommendations for the design philosophy for information architecture.

1. Information should be organized hierarchically from high level plant process information at the top level, to lower level component function and status information at the lowest level.
2. Information related to process control logic or diagnostic information related to individual sensors or instrumentation should be available on demand but should not be presented on the higher-level process control displays.

3.3.2 Technical basis

In a modern DCS, the information architecture is a direct reflection of the hierarchical structure of sensors, transmitters, device controllers, process controllers, group controllers, and sequence controllers.

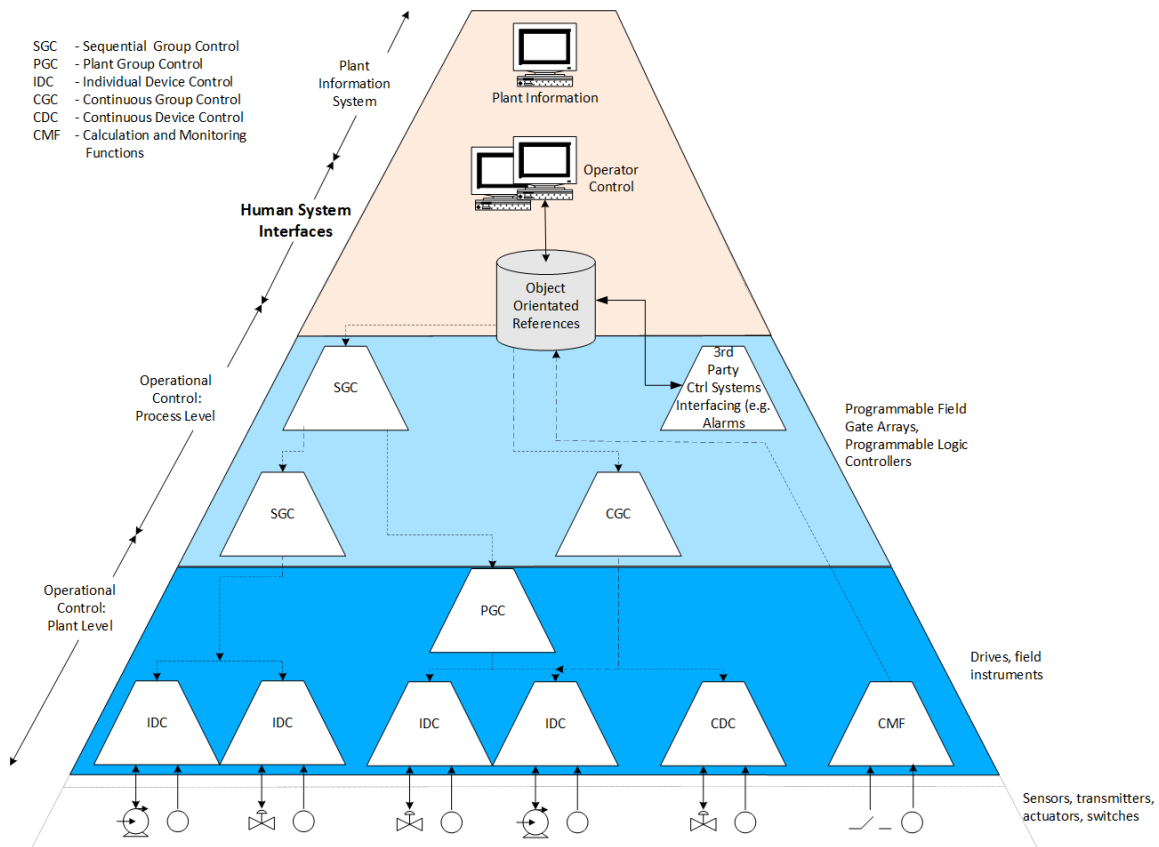

Figure 60. Typical automation system hierarchy.

This hierarchy can, in most cases, provide the basis for the structure of the HSI and the plant information interfaces, which then form the top of the hierarchy, as shown in the diagram. This can also serve as the basis for the way information is structured and displayed to operators.

3.4 Overviews

In the literature on overview displays, three terms are often conflated: Large Screen Display, Overview Display, and Group View Display. The ambiguity is also found in NUREG-0700 (see the description of “group view displays” in Section 6, p. 313), but it does make a useful distinction between the two uses of overviews:

1. An overview of an information structure, for example, a navigation scheme for the HSI (also called “display network”, similar to a “site map” on a web site). This is considered essential for user interface management and also useful to show the user’s current location within the information structure.
2. Large screen displays that enable multiple individuals to refer to the same information and allow individuals to move about the control room while still viewing the information.

These terms are ambiguous and it is recommended that the following simple definition be adopted: *“An Overview Display in the control room is a summary of information for sub-processes of the system of interest, presented to the operator in one display.”*

3.4.1 Design Philosophy

This section provides recommendations for the design philosophy for overviews.

3.4.1.1 Overview display design

1. System overviews should provide an abstracted representation of overall system status.
2. System overviews should provide functional information and provide physical information in the form of simplified process mimics where appropriate (see Section 2.6.2 for more detail).
3. System overviews should contain embedded information such as trends, indications of alarm states, and indication of process control parameters.
4. System overviews should contain graphics sized and colored for recognition of status by all personnel with need to ‘at-a-glance’ understand system status (section 2.7.1.2.1).
5. System overviews should be designed to be task-based. The number and type of tasks supported will vary by system but will include the following at a minimum. Additional high-consequence or critical tasks should be identified for each system based on frequency of task, impact of task to operations, and the potential to increase efficiency and safety by directly supporting those tasks with a tailored task-based display.
 - a. System start up
 - b. System shut-down
 - c. System steady-state normal operation

3.4.1.2 Overview display application

1. System overview should be designed for use by an operator at the boards for a hybrid control room. System overview may also be used to provide shared situation awareness in the control room by way of other operators or supervisors accessing a duplicate display from a workstation. For this reason overviews do not need to be designed to be read from across the control room.
2. Information from multiple indicators need to be integrated to understand the state of a complex system.

3. Overview displays should be available when several operators must find and understand the status of a system at the same time.
4. All overview displays should be available at all workstations in the control room.
5. Overview displays should be available for operators that need information about a system when they are not standing at the boards to control the system.

3.4.2 Technical basis

An overview display is a tool operators can use to quickly gain awareness of a system status. In the event an alarm actuated or an unexpected plant event has occurred the overview is the first place an operator can go to begin diagnosis. From the overview display the proper process control or diagnostic detail can be navigated too. In general terms, an overview displays function is to provide the following on the system they represent:

1. Provide an overview of the state of the plant or process.
2. Support situation awareness.
3. Provide support for the rapid event diagnosis.
4. Support operators' co-operation, collaboration and coordination of activities.

Overview displays are best applied to the top two levels (level 1 and level 2) of the plant performance information hierarchy. See ANSI/ISA-101.01 (2015) “Human Machine Interfaces for Process Automation Industries”, Section 6.3, p. 43-46. See also <http://mycontrolroom.com/services/human-machine-interface-hmi-design/>. The levels can be defined as the following:

Level 1: This is the top level of the plant performance information hierarchy. It represents the “span of control” of the whole plant and contains primarily the critical performance parameters (CPPs) for a rapid assessment of overall plant status. This means that it provides information about the entire responsibility of an operator, which in most cases is the same as for the whole process. This type of display is usually a read-only display and offers qualitative information with high information density.

Level 2: overviews represent the performance information (CPPs) of a specific process unit (e.g., a major system section, such as feedwater control). It presents information as well as some interaction support for the main process areas of the system.

Lower levels of information (e.g., levels 3 and 4) typically represent process control and diagnostic detail, and can no longer be regarded as “overviews”.

For further refinement of the definition provided above, it is recommended that in its implementation, a distinction is made between the physical and functional form of the OD as well as the particular level of information in relation to the overall control room information architecture:

Functional: a general description or outline of something. “General description” means a summary, simplification, or a defined level of abstraction of detail information.

Physical: graphical and textual representation of information about the physical system at a defined level of abstraction.

Effective overview displays provide information integrating many sources of data to communicate ‘at-a-glance’ system status to an operator. Extensive discussion of the difference between data and information and how to effectively populate a display with information and preserve salience can be

found in: Hollifield, B., Oliver, D., Nimmo, I. and Habibi, E. (2008) *High Performance HMI Handbook*. PAS.

Operators should be able to use overview displays as tool to quickly gain a sense of another system status in a moment no matter the system location in the control room. This can be accomplished using large screen displays such that can be seen from anywhere in the control room. It can also be accomplished by making the overview display available to all work stations in the control room as well as on the boards nearby their representative systems.

- Several operators must find and understand the status of a system at the same time
- An operator needs the information from an overview but is not standing within viewing distance of current board indicators.
- Operators have to coordinate their actions and/or have to work together

3.5 Use of Mimics

The term “mimic” means an imitation of something else. In an industrial environment, a mimic is a visual representation of certain aspects of a plant or system’s function, layout, or appearance. In this sense it can be regarded as a “model”, that is, a simplified version, of a specific view of the system. NUREG-0700 defines “mimic display” as follows:

“A mimic is a display format combining graphics and alphanumeric used to integrate system components into functionally oriented diagrams that reflect component relationships. For example, a mimic display may be used to provide a schematic representation of a system. A diagram is a special form of a picture in which details are only shown if they are necessary for a task. Mimics and diagrams should contain the minimum amount of detail required to yield a meaningful pictorial representation” (see page 2 and page 38, 1.2.8). (A simplified form of this definition is also found in NUREG/CR-6635 (Stubler et al, 2000), which preceded the -0700 definition).

3.5.1 Design Philosophy

This section provides recommendations for the design philosophy for use of mimics.

3.5.1.1 *Appropriate applications of a mimic*

1. Process flow mimics are appropriate when the configuration of the system changes the status, function, or outcome of the process.
2. System mimics are appropriate when it is important to see the alignment of individual components in the overall context of the system in order to understand how the system will behave.
3. System mimics should show embedded information including trends, alarms, set points, and any other information that is necessary to understand the status of the system.
4. System mimics are appropriate when displaying interrelatedness between system processes.

3.5.1.2 *Appropriate mimic design*

1. A mimic should be simplified and only show the information relevant to understand potential system statuses or configurations.
2. A mimic should show high-level information of process flow.
3. Mimic should be colored and spaced to preserve salience of most important information.
4. Mimic product streams should be assigned color value in cases where more than one product stream is displayed.
5. Assigned product stream colors should be consistent across all plant mimics.
6. Where possible, system mimics should show relevant functional information in addition to physical characteristics.

3.5.2 Technical basis

In the control room, a mimic diagram provides the operator with an overview of the status of the plant or system. Dynamic data shown on the mimic is updated automatically with telemetered, calculated and manually updated data from the plant process computer’s database. The higher level nature of the information derived from mimics requires a simple display scheme absent of any unnecessary information. For instance, repurposing a piping and instrumentation diagram as a mimic display is a poor strategy to design development (Hollifield et al., (2008) “The High Performance HMI Handbook”. PAS).

However, for a more extensive breakdown of the appropriate amount of information for each display level see ANSI/ISA-101.01 (2015) “Human Machine Interfaces for Process Automation Industries”, Section 6, p. 40, 41.

The user interface for such control systems is often a direct visual representation of their controller architecture, in the form of flow diagrams and buttons to actuate system controllers that should contain “the minimum amount of detail required to yield a meaningful pictorial representation” (NUREG-0700, Section 1, p. 38ff). Modern displays usually include trending graphs and alarm displays. Some displays may even use animation.

The literature suggests the industry understands the main purpose of an operator mimic is to help monitor the system status and quickly identify problems and causes. Part of rapid identification is clear demarcating of product flow paths in a process mimic. Field research found assigning color coding to product streams aids in more accurate and rapid identification of system statuses (see section 2.6.4.2 and 2.2.1.7 of this report for further information). Careful consideration to the color selection should be applied to maintain salience or “information importance” of other information on the mimic (Ha, J.S. (2013) “A Human-Machine Interface Evaluation Method Based on Balancing Principles”. *Procedia Engineering*).

Since the HMI links the operator to the industrial process, the industry is aware of the importance of good design. Operators should be able to quickly recognize which information needs their attention and what it indicates. For that, the operator not only needs a good user interface, but a system designed for effectiveness, efficiency, safety, and user satisfaction. A seminal guideline for developing a design mitigating human error is NUREG/CR-6635 (2000) “Soft Controls: Technical Basis and Human factors Review Guidance”.

Mimics are used widely in process industries, especially as displays for supervisory control and data acquisition (SCADA) systems. These systems have evolved to the state where control systems now consist of networked, advanced control and monitoring devices. The capability of these systems should be matched by their design. For instance, properly applying color and leveraging salience in a design is a primary component of a human factors design approach (Ha, 2014). Important to understand is the proper application of mimics. Wide use does not always translate to appropriate use. In addition to the philosophy above Section 6.2, p. 14 of IEEE 1289-1998: “IEEE Guide for the Application of Human Factors Engineering in the Design of Computer-Based Monitoring and Control Displays for Nuclear Power Generating Stations” has meaningful information regarding the appropriate application of mimics.

3.6 Use of Color

Color encompasses a wide variety of meanings in nuclear power plants (e.g. distinguish categories, indicate component status, signals alarms) and is characterized on an analog system differently compared to a digital system. A large amount of nuclear power plant control rooms utilize color to characterize group functionality such as feedwater and electricity on analog control systems and the chosen colors are typically painted onto the analog displays. However, with digital control displays, degrees of salience must be considered as chosen colors may change depending on the screen resolution and brightness. The following philosophy was developed with these considerations in mind to support designs for digital nuclear systems.

3.6.1 Design Philosophy

This section provides recommendations for the design philosophy for use of color.

1. The design should reserve color for only critical information. As such, an adoption of the dull screen approach, using muted shades of grey for static display elements with reserving color for dynamic display elements may be used to ensure critical information maintains highest visual priority.
2. Color coding may be used in circumstances where distinguishing between different display elements supports operation and would be challenging using shades of grey. The display should use muted colors for this type of color coding
3. The display should use saturated color only to identify abnormal operating conditions that require operator intervention.

This philosophy presents a potential conflict in the stereotypical use for red/green color schemes in the nuclear industry when presenting the status of a valve or pump. Instead of using a saturated red and green to indicate the status of a pump; this design philosophy suggests using a white/grey color scheme. One driving factor that led researchers to investigate an alternative color scheme is that a common mistake among nuclear power plants is to overuse and/or misuse color within designs. A typical issue that arises among these plants is that color is not the sole discriminator of important status conditions. The same color is often used for multiple purposes. For example, a saturated red is meant to indicate alarms statuses, but the same color is also used to designate various equipment indications (open/charged) which minimizes its overall significance.

3.6.2 Technical basis

Dull screen schemes have been suggested for digital interface designs across industries for decades (Rambally, G., & R. Rambally, 1987). When dull screens are applied, saturated colors are reserved for the most essential information such as alarms. This philosophy helps operators quickly identify when there's an issue with the plant. Additional digital interface design guidance has surfaced in the nuclear industry as well. The following contains all applicable guidance derived from NUREG-0700 Rev. 2 as well as EPRI 3002004310 guidance pertaining to color association in general nuclear power plants for a digital control system. See Table 17.

Table 17. HFE Design Guidance for Use of Color

| Guidance | Recommendation |
|--------------------|---|
| NUREG 0700 1.3.8-4 | Colors for coding should be based on user conventions with particular colors. Color codes should conform to color meanings that already exist in the user's job. Color codes employing different meanings will be much more difficult to use. |
| NUREG 0700 1.3.8-7 | When color coding is used to group or highlight displayed data, all of the colors in the set should be readily discriminable from each other. |
| NUREG 0700 1.3.8-8 | When color coding is used, each color should represent only one category of displayed data. |

| Guidance | Recommendation |
|------------------------------|---|
| EPRI 3002004310 4.2.6.8.1-1 | Color use and the meanings attached to colors should be consistent throughout the plant as well as within a specific upgrade project. |
| EPRI 3002004310 4.2.6.8.1-2 | Color should be utilized as part of the overall labeling and demarcation strategy. |
| EPRI 3002004310 4.2.6.8.1-3 | Color should be used as part of the overall strategy to emphasize particular items of information. |
| EPRI 3002004310 4.2.6.8.1-4 | Colors should be considered for use as part of the overall strategy to identify the status of components or systems. |
| EPRI 3002004310 4.2.6.8.1-5 | Color should be considered for use as part of the overall strategy to convey the magnitude of measured quantities. |
| EPRI 3002004310 4.2.6.8.1-6 | The number of colors should be limited to those that can be easily distinguished. |
| EPRI 3002004310 4.2.6.8.1-7 | Colors should have adequate contrast and luminance with respect to the surroundings. |
| EPRI 3002004310 4.2.6.8.1-8 | The uses of color as a coding should normally be backed up with another coding method. |
| EPRI 3002004310 4.2.6.8.1-9 | When a user must distinguish rapidly among several discrete categories of data, a unique color should be used to display the data in each category. |
| EPRI 3002004310 4.2.6.8.1-10 | When color coding is used, each color should represent only one category of displayed data. |
| EPRI 3002004310 4.2.6.8.1-11 | Color coding should not create unplanned or obvious new patterns on the screen. |
| EPRI 3002004310 4.2.6.8.1-12 | Colors and color combinations that may cause problems owing to the workings of color vision should be avoided. |

According to these criteria a digitally represented system such as the BAC/LRS mimics should possess colors that conform to the color meanings that already exist within the associated plant to avoid confusion. If no pre-existing color associations exist, there is basis to propose an all new color association scheme. Table 18 is an adaptation from NUREG-0700 Rev. 2 Table 1.3, which lists recommended color associations for general nuclear power plants.

Table 18. Common Associated Meanings of Select Colors Used in the Nuclear Industry

| Color | Associated Meanings | Attention-Getting Value |
|-------------------|--|--------------------------------|
| Red | Unsafe Danger Alarm State Hot Open/flowing Closed/stopped | Good |
| Yellow | Hazard Caution Abnormal State Oil | Good |
| Green | Safe Satisfactory Normal State Open/flowing Closed/stopped | Poor |
| Light Blue (cyan) | Advisory Aerated Water Cool | Poor |
| Dark Blue | Advisory Untreated Water | Poor |
| Magenta | Alarm State | Good |
| White | Advisory Steam | Poor |
| Black | Background | Poor |

3.7 HSI Navigation

NUREG/CR-6690 (O’Hara and Brown, 2002) defines navigation as “*the access and retrieval of a specific aspect of the HSI, such as a display or control. Navigation may include accessing a single display page from a network of display pages or accessing a specific item from within a display page, when manipulations of the display system are necessary*” (p. 86)

3.7.1 Design Philosophy

This section provides recommendations for the design philosophy for HSI navigation.

1. HSI navigation should be presented in a logical manner that follows the information architecture and the mental model of the operators. The following is a conceptual scheme for accessibility and visibility of different display types:

Table 19. Operator Displays

| Display Number | Display type | When | Options |
|----------------|--|--|---|
| 1 | Plant Overview Display (Critical Performance Parameters) | Always (this is vital for situation awareness) | Any one (full screen) or a combination of two of the following: 1. Dynamic State Transition Diagram 2. Plant Signature Diagram 3. Simplified Plant Mimic |
| 2 | High-Level Process Information (System Overviews) | All plant states from refueling to full power | Any one of the following: 1. Primary loop (Rx, RCS, SI, SFP, etc.) 2. Secondary Loop (S/G, FW, etc.) 3. Turbine-Generator Control 4. Reactor Control 5. Other System Overviews (e.g. CVCS) |
| 3 | Detail System & Process Information | All system states from shutdown to full power | Any SSC performance information, with faceplates as required. |
| 4 | Annunciator | Always (while DCS active) | Any two of the following: 1. Alarm tiles (more than one display page as required) 2. Alarm list (scrollable) 3. Event history (scrollable) |
| 5 | Operator Support | All states (while DCS active) | Any of the following: 1. Navigation display 2. Operating Procedures (graphical and text) 3. System drawings (P&IDs, process flow, layouts, etc.) 4. Technical manuals (Operating Technical Specifications, Maintenance manuals, etc.) |
| 6 | Equipment Protection System Display | Always | (Out of scope for LWRS control room modernization) |

2. Access to displays one level above or below the current level in the hierarchy should be no more than one action (e.g., click or keystroke) away.
3. All available functionality in the display should be continuously visible or no more than one action away.
4. Accessing the highest level display in the hierarchy should be no more than one action away.
5. The display shall provide a visual representation of the main navigation architecture for overview.

3.7.2 Technical basis

The information architecture also influences the navigation scheme, and the hierarchy presented in Figure 60 can also serve as the basis for the structure of the HSI and the plant information interfaces, which then form the top of the hierarchy, as shown in the diagram. This means it can also serve as the basis for the navigation scheme implemented in the HSI. Industry best practice suggests that a good navigation scheme would provide a visual metaphor relevant to the system to enable the operator to navigate effortlessly in and between the following information spaces:

- plant layout
- processes
- systems and components

Suitable navigation metaphors may range from abstract diagrams (for example process maps or functional flow block diagrams), to realistic representations of components. A good visual navigation scheme would provide a way for the operator to seamlessly step backwards to the previous space or state. Wherever possible, the design should allow the operator to step backwards multiple steps or provide a way to navigate directly to a checkpoint of the operator's choice. As always, navigation metaphors must be tested for comprehensibility and communicability. Usability tests should reveal the following (see NUREG-0700, section 2.5.1.2-3 and section 8.3.2-3):

- Shortest path between two points (e.g. screens)
- Availability of a direct path to the main display from all screens
- Overview of the main architecture
- Traceable path ("breadcrumbs") on all displays

3.8 Controls

Controls are the devices used by plant personnel to interact with the HSI and the plant. Broadly categorized, design of controls described in this section can apply to conventional (i.e., analog) controls and embedded soft controls within the digital HSI.

3.8.1 Design Philosophy

This section provides recommendations for the design philosophy of controls. Specific sub-sections are listed to capture key control design topics including: Placement of HSIs with Controls, Interaction with Controls, Soft Control Design and Format, and Error Prevention and Recovery.

3.8.1.1 *Placement of HSIs with Controls*

4. For standing operations, placement of HSIs with embedded controls that require extended reach should not be directly behind analog safety-related controls to avoid inadvertent activation.
5. Alternative input devices such as a mouse or trackpad should be available at standing control consoles that require the operator to reach for specific controls outside his or her functional reach envelope. The location of the alternative input device should be positioned directly in front of the corresponding HSI and any analog safety-related controls (i.e., the operator should not have to reach over safety-related controls in any circumstance).

3.8.1.2 *Interaction with Controls*

6. Controls faceplate should be designed such that the relevant information related to operating the equipment is not obscured by the control faceplate.
7. The manner to which controls are accessed should be consistent across HSIs.
8. The control faceplate should appear on the screen in a manner that minimizes the distance from the control to task-relevant information and the distance an operator needs to move the control.
9. Controls should provide unambiguous feedback on the status of the equipment and related information such as current set points for control parameters.
10. Controls should be presented within operational context (e.g. highlight equipment on overview or mimic display). When multiple plant components are associated with a single controller and are visually depicted on the display such as by a mimic format, highlighting this relationship on the display is recommended.
11. All available or routinely used functions for control of equipment or components should be continuously visible or a maximum of one click away.

3.8.1.3 *Soft Control Design and Format*

12. The selection of soft control design and format should consider the primary input device to be used (e.g., button size and spacing should accommodate finger anthropometry if touch is primary input).
13. The design of soft controls should be consistent across HSI displays.
14. The design of specific soft control formats including numeric entry fields, sliders, as well as discrete-adjustment and arrow buttons should follow industry-accepted HFE design guidance such as described in NUREG-0700 7.2.3 and 7.2.4.

15. Soft controls should use informative labels for identification and associating with corresponding plant components.

3.8.1.4 Error Prevention and Recovery

16. When soft controls can be accessed from multiple locations, the soft control system should provide indication of each operator's action to ensure shared situation awareness. Actions with significant consequences to the plant that are on the soft control system (e.g., a trip function) should be only accessible from a single location.
17. Actions with significant consequences should require verification of input (e.g., a two-step action sequence) to reduce inadvertent control actions.
18. A given soft control should be ideally designed for only one function (e.g., a directional arrow button should serve one purpose) to avoid mode errors. When multiple modes exist, that mode state should be clear to the operator.
19. Interface management actions (e.g., navigation buttons) should be made distinct from process control actions (i.e., such as through the visual appearance and placement of the controls on the HSI) to avoid inadvertent control actions.

3.8.2 Technical basis

The current modernization plan expects to remove 60 percent of current analog controls and indications off the control boards and replaced by soft controls on workstations. Changing input devices requires careful attention to how controls are organized in relation to their component counterpart, communicate to operator what actions may be taken, and to the range and precision required for a control action. Further considerations include those related to performance metrics such as speed, accuracy, and economy of physical and cognitive workload. The guidance here based from accepted HFE guidance including NUREG-0700 Section 3.1.1 (i.e., Control Design Principles) and Section 7 (i.e., Soft Control System), as well as specific findings from the HFE studies related to the selection, functionality, and placement of the soft controls system (i.e., see Sections 2.6.1, 2.6.2, 2.7.3, and 2.7.4). The following sub-sections describe the relevant content that support the design philosophy for controls. These sub-sections are described as: General Guidance for Controls, Specific Guidance for Soft Control Systems, Findings from HFE Testing and Evaluation.

3.8.2.1 General Guidance for Controls

General guidance for control design is based from NUREG-0700 Rev. 2 Section 3.1.1. A summary of important aspects that affect the selection and design of controls are summarized as follows.

Controller characteristics. The proposed method for component control is a mouse pad and keyboard located at either or both a workstation where the operator may sit down and at the control boards where redundant control systems may be located. The location within the control room as well as the equipment selected is based on best practice and ergonomically sound principles taking into consideration frequency, duration, and precision required of the physical tool to interact with the system.

Controller component relationship. A clear link between a control faceplate and the component of interest is necessary for accurate control interaction. A single spatial designation for all controller faceplates means highlighting the component being controlled with clear noun names, and equipment identifications on both the controller faceplate and equipment for redundant checks that controller matches the intended component. If a non-spatially designated area faceplate is used, then both highlighting and proximity to component of interest is used as well as equipment identifications to confirm matching controller and component. If a control screen is more appropriate to a system, then the

system and all equipment controllable from the control screen is disambiguated from equipment not accessible from the current control screen. Equipment identification numbers and noun names will still be present and associated to each controller by proximity.

Controller faceplate content. A controller faceplate simultaneously represents all available control options to the operator when visible. All current settings, values, set points, equipment status, are available on the controller faceplate. Any content that does not aid equipment identification or control status and range is not included on the faceplate to avoid clutter. The controller faceplate also contains information related to availability of the equipment. If a piece of equipment is offline, the information should be presented alongside the controls.

Controller display area. The control display should be placed where it does not occlude the information needed to gain feedback from the current control actions. Furthermore, it should either disappear or be placed where the control faceplate does not impede long-term monitoring of the system.

Error prevention or correction. Equipment statuses are available at various display levels to feedback control action consequences to operators to ensure proper operation. All component controls will be continually accessible to change or alter a setting if an improper input or action was taken previously.

Control Availability. All controls on a system control screen are continuously available though not always present. Faceplates are accessible through intuitive interaction with components such as clicking the component requiring a control action. However, if the display containing the equipment information related to the control is not responding, the control should also not be available from that particular workstation.

Initiating action. Actions to control equipment are clearly distinguishable from actions that navigate HSI interfaces. Furthermore, the synchronizing of at least two actions must occur for each control action. Since a mouse is the primary tool for interaction hovering and clicking over the desired control must occur before a change in the system state does. Simply hovering may provide more information but cannot be sufficient for a control action. Some control actions may require three movements such as hovering, clicking, and dragging.

One control action for a complex sequence. Using a soft interface introduces the capability to automate a sequence of related actions initiated by a single control action. If appropriate and necessary to do so, the sequence of actions is clearly defined on the HSI and viewable from the operators' position at the controller. The current action being performed by the automation is shown and visible to operator from the position at the controls. At any time, the automated actions can be halted unless doing so risks plant or operator safety.

Intuitive control actions (NUREG-0700). Control movements should conform to population stereotypes. NUREG-0700 section 3.1.1-16 provides a descriptive figure (Figure 61) of how a control action may influence the system. Despite the figure referring to hard knob controls, the same stereotypes are applicable to soft control sliders and button organization.

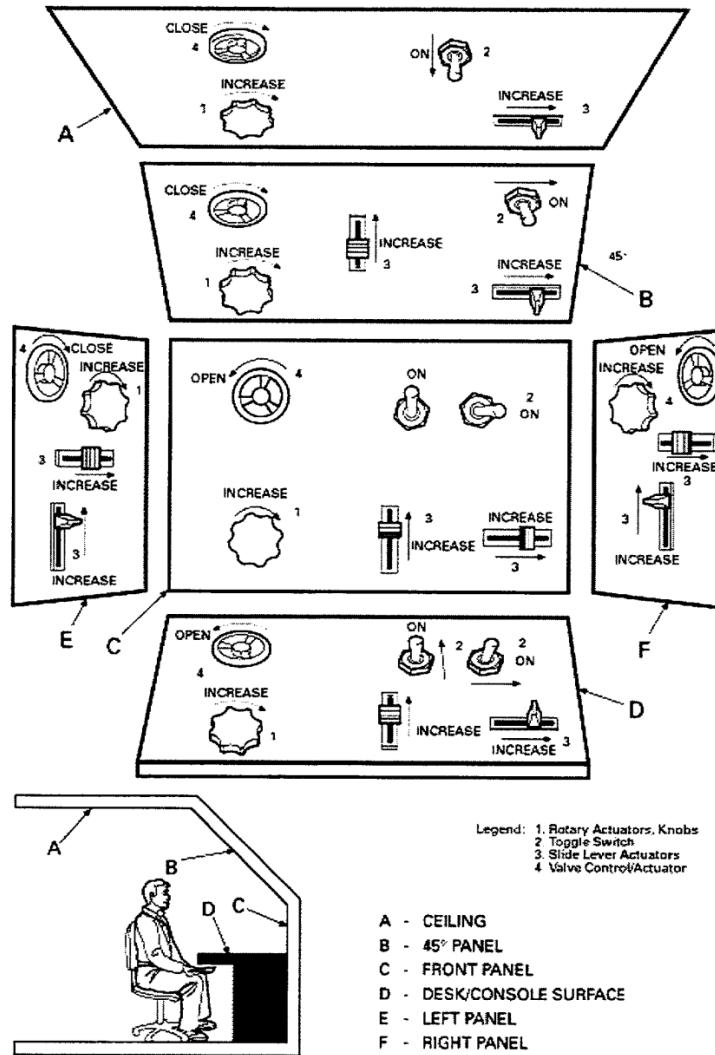

Figure 61. Control operation stereotypes for U.S. population. Adopted from NUREG-0700 Figure 3.1.

It should be noted that the technical basis of the control design philosophy is not always rooted in empirical findings suggesting the current philosophy is 'best practice.' Challenges such as conflicting philosophy in specific situations may be met with critical approaches to determine how best to manage trade-offs in favor of the safest, most effective and efficient soft control design in a control room.

3.8.2.2 Specific Guidance for Soft Control Systems

Per NUREG-0700 Rev. 2, **Soft control systems** can be defined as,

"The basic function of soft control systems is to provide operators with control interfaces that are mediated by software rather than by direct physical connections. Soft controls can be used to control plant equipment, such as a pump, or the human system interface (HSI) itself, such as display selection."

Specific guidance for soft control systems is based from NUREG-0700 Rev. 2 Section 7. A summary of important aspects that affect the design of the soft control system is provided below in Table 20.

Table 20. Key Guidelines from NUREG-0700 Specific to the Design of the Soft Control Systems

| NUREG-0700 Section 7 Categories | No. | Title | Description |
|---------------------------------|----------|--|--|
| General | 7.2.1-1 | Representing Relationships Between Control System Components | The display capabilities of soft controls should allow users to quickly assess the status of individual components of a control system and their relationships with other components. |
| | 7.2.1-2 | Making Options Distinct | The interface should be designed so that users can, at a glance, distinguish options by such characteristics as context, visually distinct formats, and separation. |
| Information Display | 7.2.4-1 | Appropriate Use of Discrete-Adjustment Interfaces | Discrete-adjustment interfaces should be used for selecting among a set of individual settings or values. |
| | 7.2.4-2 | Labelling Selection Options in Discrete-Adjustment Interfaces | The selection options in discrete input formats should be clearly labelled. |
| | 7.2.4-3 | Feedback for Discrete-Adjustment Interface with Multiple Settings | Discrete-adjustment interfaces should indicate which setting was selected. |
| | 7.2.4-4 | Feedback for Discrete-Adjustment Interface with Continuous Operation | If a discrete-adjustment interface has continuous operation, it should provide continuous feedback on the current state. |
| | 7.2.4-5 | Appropriate Use of Continuous-Adjustment Interfaces | Continuous-adjustment interfaces should be used when precise adjustments along a continuum are needed or when many discrete settings are present. |
| | 7.2.4-6 | Appropriate Use of Soft Sliders | A soft slider should be considered as an input device when the range of possible values and the ratio of a value to that range need to be displayed. |
| | 7.2.4-7 | Indicating the Range of Values on Soft Sliders | The range of values should be indicated on horizontal sliders with the low value on the left and the high value on the right, and on vertical sliders with the low value on the bottom and the high value on the top. |
| | 7.2.4-8 | Displaying the Digital Value on Soft Sliders | The numerical value to which a soft slider is set should be presented in digits on the soft slider. |
| | 7.2.4-9 | Dimensions of Soft Sliders | The physical dimensions of the soft slider should allow the user to read the current and target positions and position the slider with the required precision, accuracy, and response time. |
| | 7.2.4-10 | Depicting Critical Ranges on Soft Sliders | When part of the range of values depicted by a soft slider represents critical information, such as alarm limits, those values should be coded to facilitate recognition. <i>Additional Information: Graphical codes may be applied to distinguish the normal operating range, alarm limits, and other abnormal operating ranges.</i> |
| | 7.2.4-11 | Appropriate Use of Arrow Buttons | A set of arrow buttons should be considered as the input device when it is desirable to incrementally increase or decrease a variable from its previous value. |

| NUREG-0700 Section 7 Categories | | No. | Title | Description |
|---------------------------------|----------------|----------|--|---|
| | | 7.2.4-12 | Indicating Current Value for Arrow Buttons | Arrow buttons should have a display indicating the current value of the variable being controlled. |
| | | 7.2.4-13 | Uniform Changes in Values Via Arrow Buttons | Each press of an arrow button should change the current value uniformly. |
| | | 7.2.4-14 | Feedback Regarding Arrow Button Actuation | Arrow buttons should provide salient feedback when they are actuated. |
| | | 7.2.4-15 | Apparent Operation of Arrow Buttons | Labelling and other coding should be used when the operation of the arrow buttons is not apparent. |
| | | 7.2.4-16 | Reference Values For Continuous Variable Inputs | Reference values should be provided to help the user judge the appropriateness of values when entering continuous variable inputs. |
| User-System Interaction | General | 7.3.1-1 | Minimizing Soft Control Modes | The excessive use of modes in soft controls should be avoided. |
| | | 7.3.1-2 | Distinctive Indication of Soft Control Modes | When multiple modes exist, they should be distinctively marked so the user can determine the current mode at a glance. |
| | | 7.3.1-3 | Coordination of Destructive and Safety-Significant Commands Across Modes | A command that produces a benign action in one mode should not cause a different action with serious negative consequences in another mode. |
| | | 7.3.1-4 | Unique Commands for Destructive and Safety-Significant Commands | Unique commands associated with actions that have important consequences should not be easily confused with other commands used in the same or different modes. |
| | | 7.3.1-5 | Discrimination of Interface Management Actions and Process Control Actions | The design of the user interface should clearly distinguish between interface management actions and process control actions. |
| | | 7.3.1-6 | Reducing the Likelihood of Unintended Actuation | For actions that can have significant negative consequences, the user interface should be designed to reduce the likelihood of unintended actuation by requiring deliberate action for their execution. |
| | | 7.3.1-7 | Feedback For Selected Actions Before Execution | The HSI should give the user feedback indicating the action that was selected and allow the action to be cancelled before it is executed. |
| | | 7.3.1-8 | Use of Error-Mitigation Approaches | Error-mitigation approaches should not be the sole means for achieving error tolerance, but should be used in conjunction with other means for error prevention and system-assisted error detection. |
| | | 7.3.1-9 | Undo Features | If undo features are provided they should be consistently available. |
| | Control Inputs | 7.3.7-1 | No Activation When Display Is Inoperable | Users should not be able to activate a soft control if its display is not working. |
| | | 7.3.7-2 | Automatic Reset of Multi-Variable Controls | If an input device controls more than one variable, the user should not have to reset the device to match the value of the new variable before executing a control action. |
| | | 7.3.7-3 | Numerical Input Values | The HSI should provide feedback to support the user in verifying the correctness of numerical values entered. |

| NUREG-0700 Section 7 Categories | No. | Title | Description |
|---------------------------------|---------|--|--|
| System Response | 7.3.9-1 | Actuation Feedback | Soft controls should provide feedback about their operating state after activation. |
| | 7.3.9-2 | Notification of Automatic Mode Changes | Systems that can change mode automatically should provide feedback to make the user aware of the current mode. |
| | 7.3.9-3 | Delaying System Response | Where appropriate, systems that are sensitive to incorrect inputs should be designed to limit the rate at which these inputs can affect the process. |

3.8.2.3 Findings from HFE Testing and Evaluation

Findings from the HFE testing and evaluation activities described in Sections 2.6.1, 2.6.2, 2.7.3, and 2.7.4 were considered in the overall design philosophy of controls. These can be summarized as follows:

- The distance from a control to its corresponding display element (e.g., a process value on a display) should be minimized to reduce visual search requirements of the operator. See Sections 2.6.1.3.4 and 2.7.3.3.1.
- Accessing soft controls from an HSI should have a consistent convention. For example, operators commented that consistency regarding the location of where the soft control faceplate appears is important. See Section 2.7.3.3.1.
- When HSI displays with embedded touch-input control are positioned outside the functional reach for most operators on a control board for standing operations, an alternative input device such as a mouse or trackpad should be available. See Section 2.7.4.3.
- Placement of HSI displays with embedded control positioned on a control board for standing operations should not be placed directly behind analog safety-related controls to avoid inadvertent activation. See Section 2.7.4.3.

3.9 Integrated Displays

Integrated displays, as described in this document, visually show multiple types of information (e.g., equipment status, alarm indications, etc.) within a single display page, as opposed to showing these types of information on separate display pages. To note, an integrated display *should not* be confused with an *integral display*, which is a format of display that shows information in a way that individual parameters are not explicitly represented.

3.9.1 Design Philosophy

This section provides recommendations for the design philosophy of integrated displays.

1. Important information that is required for frequent monitoring should be integrated for the operator wherever possible.
2. Soft controls should be integrated for the operator wherever possible.
3. Information should be grouped by a convention obvious to the operator.
4. The presentation of information on an integrated display should be in a clear, logical, and uncluttered format for the operator.
5. Displays should contain all information for the safe operation of a system including information from related systems if there are system dependencies that must be considered by the operator.

3.9.2 Technical basis

The amount of information presented in a control room has the potential to overload an operator. An integrated display is designed to help lower the workload associated with obtaining useful information from the abundance of data in a control room. One central advantage of the integrated display pertains to minimizing the viewing distance for important information required for frequent monitoring. Motivation for centralizing important information can be traced to HFE guidance for the location of frequently monitored displays (i.e., NUREG-7000 11.1.1-7 and 11.1.2-6), suggesting that information that is frequently monitored should be

- no more than 35-degrees to the left or right of the operator’s line of sight, and
- no more than 35-degrees above (i.e., and 20-degrees above when seated) and 25-degrees below (i.e., and 40-degrees below when seated) the operator’s horizontal line of sight.

Ultimately, the optimal viewing location for important information is constrained in visual space, which strongly supports the use of integrated displays. NUREG-0700 Rev. 2 and EPRI 3002004310 provide design guidance that provides the technical basis of using integrated displays in nuclear power plants for a digital control system. Additionally, findings from Section 2.7.3 identified that operators preferred having soft controls integrated into a single display. Guidance from these resources are as follows in Table 21.

Table 21. Key HFE Guidance for Integrated Displays

| Guidance/ Related Findings | Applicable Guidance | |
|---|---------------------|-----------------|
| | NUREG-0700 Rev. 2 | EPRI 3002004310 |
| A standard display screen organization should be evident for the location of various HSI functions (such as a data display zone, control zone, or message zone) from one display to another. | 1.5-1 | 4.2.3.2-1 |
| The HSI functional zones and display features should be visually distinctive from one another, especially for on-screen command and control elements (which should be visibly distinct from all other screen structures). | 1.5-2 | 4.2.3.2-2 |

| Guidance/ Related Findings | Applicable Guidance | |
|--|---|-----------------|
| | NUREG-0700 Rev. 2 | EPRI 3002004310 |
| Displays should present the simplest information consistent with their function; information irrelevant to the task should not be displayed, and extraneous text and graphics should not be present. | 1.5-6 | 4.2.4.3-1 |
| Redundancy in the presentation of information items should be limited to cases where needed for backup or to avoid excessive movement. | 1.5-7 | 4.2.4.3-2 |
| Displays should be as uncluttered as possible. | 1.5-8 | 4.2.4.3-3 |
| When displays are partitioned into multiple pages, function/task-related data items should be displayed together on one page. | 1.5-9 | 4.2.4.1-5 |
| Users viewing a portion of a larger display should be provided with an indication of the location of the visible position of a display (frame) in the overall display. | 1.5-11 | 4.2.4.1-7 |
| Information on a display should be grouped according to principles obvious to the user, e.g., by task, system, function, or sequence, based upon the user's requirements in performance of the ongoing task (see Table 1.5). | 1.5-12 | 4.2.4.2-3 |
| When information is grouped on a display, the groups should be made visually distinct by such means as colour coding or separation using blanks or demarcation lines. | 1.5-13 | 4.2.4.2-5 |
| Where possible, soft controls should be integrated into a single display with related information for the operator. | N/A – Finding identified from Section 2.7.3 of this report. | |

3.10 Use of Graphics

Graphics can be broadly defined as data that is specially formatted to show spatial, temporal, or other relations among data sets (i.e., see NUREG-0700). A *graphical display* is typically used to present graphics through pictorial representation of the object or data set.

3.10.1 Design Philosophy

This section provides recommendations for the design philosophy of the use of graphics.

3.10.1.1 General graphic design

1. The format of graphics should be selected based on the goals of user's tasks. Design input from users should be collected to determine the appropriate graphical format for various data used in operations.
2. The selection and format of a display should be consistently applied across display pages. For example, the rationale for selecting the use of a line graph should be consistent across display pages. The formatting of the line graphs should also be consistent (e.g., design of scales, axes, use of color, etc.) across displays.
3. Graphics should be presented in a way to which they are readily perceivable without ambiguity; the relationship of lower-level to higher-level information should be understandable to users.
4. The display should present simplified graphics and only present detail necessary to perform tasks. No unnecessary or gratuitous detail, such as 3-D depiction of tanks or other equipment, should be used.
5. No animation should be used to represent normal system states. Animation or flashing may be used to temporarily capture an operator's attention under abnormal conditions but should be removed once the condition has acknowledged or resolved.

3.10.1.2 Pump and Valve Icons

1. The variety and value of displaying specific equipment types should be based on needs of the user. Information that does not aid in diagnosis or understanding of system or component status should be left out.
2. The variety and design of icons should be consistent across all display pages.

3.10.1.3 Trends

1. Numerical values information can be increased with even brief lines to indicate change of direction but should be supported by the ability to immediately navigate to more information regarding the equipment represented by the trend.
2. Trend design should be based on the information needed by the operator. Hence, if a value is monitored to follow a target, stay within upper and lower limits, or remain steady the design of the trend should support this type of information capture.

Guidance from applicable documents such as NUREG-0700 and EPRI 3002004310 should be considered where appropriate. Design tradeoffs between conflicting guidance (e.g., minimizing interface management tasks such as navigation versus minimizing visual clutter) should be documented and remediated through design activities such as tradeoff studies and tests and evaluations throughout the course of the HSI Design process (i.e., see EPRI 3002004320 3.8.3.4).

3.10.2 Technical basis

There are various formats of graphical displays, including: Bar Charts and Histograms, Trend Graphs, Pie Charts, Flowcharts, Mimics and Diagrams, Maps, Integral and Configural Displays, and Graphic Instrument Panels. NUREG-0700 1.1-1 provides guidance on selecting the appropriate display format, which should be based on the tasks the user will perform (see **Error! Reference source not found.**). The ultimate benefit of using graphics (when used properly) is to present the data in a way that supports the operator performing informed actions or immediately detecting changes in plant conditions without having to perform other interface management tasks (NUREG-0700 1.1-14).

Table 1.1 Display formats for representative user tasks

| Representative Task | Format | Condition for Appropriate Use |
|--|---------------------|---|
| Comprehending Instructions or General Descriptions | Continuous Text | General |
| | Lists | Series of related items |
| | Speech Displays | User's attention not directed toward text display |
| | Flowcharts | Sequential decision process with no tradeoffs |
| Examining and Comparing Individual Numerical Values or Text | Tables | Detailed comparisons of ordered sets of data |
| | Data Forms | Detailed comparisons of related sets of data items from separately labeled fields |
| Examining Functional Relationships of Components of a System | Mimics and Diagrams | General |
| Examining Spatial Relationships of Objects or Places | Diagrams | General |
| | Maps | Geographical Data |
| Examining and Interpreting Patterns in Numerical Data | Bar Charts | Single variable viewed over several discrete entities or at discrete intervals |
| | Histograms | Frequency of occurrence viewed at discrete intervals of a single variable |
| | Pie Charts | Relative distribution of a single variable over several categories |
| | Graphs | Two or more continuous variables |
| | Graphs: Scatterplot | Spatial distribution of data within a coordinate system |

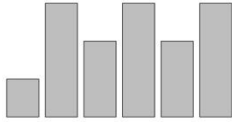



Figure 62. Display formats for representative tasks. Adopted from NUREG-0700 Rev. 2 Table 1.1.



Graphical display conventions should be consistently (NUREG-0700 1.1-2) represented across displays and be displayed consistent to the standards and conventions familiar to the users at hand (NUREG-0700 1.1-3). Graphical elements should have a one-to-one relationship with the plant entity/state that it represents (NUREG-0700 1.1-5). For instance, a change in a graphic should only be associated with one interpretation. Graphics should be presented at the level of abstraction necessary for operators to accomplish their goals (NUREG-0700 1.1-6) and also readily perceivable without ambiguity (NUREG-0700 1.1-7). The methods to which lower level data are analyzed to produce higher-level graphical information should be understandable to users where access to the rules of their computations are readily accessible (NUREG-0700 1.1-8 & 1.1-9).

Display pages containing graphics should be presented with the simplest information consistent with their functions (NUREG-0700 1.5-6); information irrelevant to the task should not be displayed. Likewise, displays should be uncluttered as much as possible. NUREG-0700 1.5-8 suggests display packing density (i.e., or the amount of space, measured in pixels, used to present information) not exceed 50-percent.

Specific design guidance for each type of graphical format can be traced in NUREG-0700 Rev.2 and EPRI 3002004310. See Table 22 below.

Table 22. Key HFE Guidance for Use of Graphics

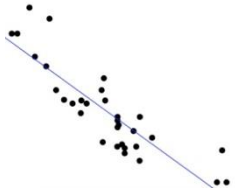
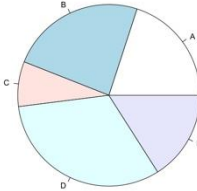
| Graphical Format | Suggested Application and Considerations | Applicable Guidance | |
|---------------------------|---|---------------------|-----------------|
| | | NUREG-0700 Rev. 2 | EPRI 3002004310 |
| Bar Charts and Histograms | <p>Bar Charts are graphical figures that represent numeric quantities via the linear extent of parallel bars (i.e., horizontally or vertically). Bar charts are used to compare magnitudes of limited number of items on a single scale.</p>  <p>Example of generic bar chart</p> <p>Histograms is a type of bar chart that depicts a frequency distribution for a continuous variable.</p>  <p>Example of generic histogram</p> | Section 1.2.4 | Section 4.2.5.5 |
| Graphs | <p>A graph is a display that depicts values of one or more values with respect to another variable.</p> <p>Line graphs are a type of graph where one or more variable (y-axis – process value) is visualized over another variable (x-axis – time).</p>  <p>Example of generic line graph</p> <p>A linear profile chart forms the upper boundary of a polygon by shading the area from the horizontal axis to the line. Linear profile charts are useful if recognizable contours are associated with specific conditions.</p>  <p>Example of generic linear profile chart</p> <p>Scatterplots visualizes the relationship between two variables (e.g., pressure as a function of temperature). The x-axis typically is not necessarily an indication of time. Data points are typically not connected as a line graph.</p> | Section 1.2.5 | Section 4.2.5.6 |

| Graphical Format | Suggested Application and Considerations | Applicable Guidance | |
|----------------------------------|--|---------------------|------------------|
| | | NUREG-0700 Rev. 2 | EPRI 3002004310 |
| |  <p>Example of generic scatterplot</p> | | |
| Pie Charts | <p>Pie charts present relative proportions of a variable (i.e., the whole) in a circular format. Pie charts should be used with caution since they [1] do not provide means of absolute judgment, [2] cannot represent values greater than 100%, and [3] only represent a fixed point in time. Further, EPRI 3002004310 suggests that estimates of relationships are better served with linear formats (see Bar Charts and Graphs).</p>  <p>Example of generic pie chart</p> | Section 1.2.6 | Section 4.2.5.7 |
| Flowcharts | <p>Flowcharts illustrate the sequential relations among elements or events, typically visualized with boxes and arrows.</p>  <p>Example of generic flowchart</p> | Section 1.2.7 | Section 4.2.5.8 |
| Mimic Displays and Diagrams | <p>A mimic display combines graphics and alphanumeric characters to integrate system components into functionally oriented diagrams. See Section 2.4 of this document.</p> <p>Diagrams are special forms of a picture where the details are only shown to the extent necessary for completing a task. For example, diagrams might be used to represent an electrical wiring scheme. In this case, only the wiring would be presented, leaving out unnecessary details like other systems (e.g., plumbing).</p> | Section 1.2.8 | Section 4.2.5.9 |
| Maps | <p>Maps are graphical representations of an area or space (e.g., layout of a room).</p> | Section 1.2.9 | Section 4.2.5.10 |
| Integral and Configural Displays | <p>Integral displays present information in an integrated format where individual parameters used to comprise the display are not represented in it. For example, an icon may be used to display the status of a system. The icon would change based on computational changes in lower-level</p> | Section 1.2.10 | Section 4.2.5.11 |

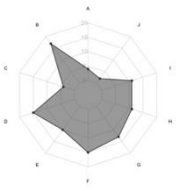
| Graphical Format | Suggested Application and Considerations | Applicable Guidance | |
|-----------------------------|--|---------------------|------------------|
| | | NUREG-0700 Rev. 2 | EPRI 3002004310 |
| | <p>parameters (i.e., which are not explicitly presented).</p> <p>Configural displays present the relationships among parameters as an 'emergent feature.' An emergent feature can be defined as a global perceptual feature (e.g., shape) produced by the interactions of many lines, contours, or shapes (i.e., denoting the individual parameters). Hence, configural displays provide both lower- and higher-level information. In the example below, several lower-level parameters are combined to form a polygon. A uniform shape may denote normal conditions whereas live changes in the shape below may indicate an abnormal condition. See Section 2.9.</p>  <p>Example of generic configural display</p> | | |
| Graphic Instrument Panels | <p>Graphic instrument panels provide graphical representations of the instruments in a control panel. These formats are best used when the user must verify that a parameter is within range. Other techniques such as bar charts will better serve tasks such as comparing a value to another parameter or standard. Exact value reading is better served via numeric readout.</p> | Section 1.2.11 | Section 4.2.5.12 |
| Icons and Symbols (General) | <p>Icons and symbols provide non-verbal representations of objects, states, characteristics, or actions. Icons and symbols are typically used to save space and support users in process visual representations through providing distinctive and easily recognizable representations. Icons and symbols are best represented when they are familiar to users, easily discriminable from each other, right-side up, and simple (i.e., without unnecessary detail).</p> | Section 1.3.4 | Section 4.2.6.4 |

3.11 Alarms

Alarms and alarm systems comprise a very large body of knowledge that cannot be covered comprehensively in this short review. For the purpose of the human factors aspects of control room modernization R&D planned for the current and upcoming phases, only the most significant issues were identified. These included:

- Current state of the art and industry best practice
- Alarm philosophy
- Alarm standards and guidelines

The definitions used for this report are:

Alarm: an alarm in a nuclear power plant is a visual and/or auditory signal that serves to call attention to, or alert a human to an impending or existing adverse condition in a system or in the environment.

Alarm System: a device or basic operator support system for managing abnormal situations and it has the following two functions:

1. The primary function of the alarm system is to notify human operators of out-of-parameter conditions that could threaten equipment, the environment, product quality and, of course, human life. The warning function helps the operator control the future behavior of a complex plant by attracting attention to undesired process conditions.
2. The secondary function of the alarm system is to serve as an alarm and event log that supports the operator's need to analyze the events that have led to the current or previous process conditions.

3.11.1 Design Philosophy

This section provides the philosophy and recommendations for designing alarms.

1. Alarms should be used to identify abnormal operating conditions and only interrupt operators when there is an immediate action that they must take.
2. Alarms should be presented alongside guidance for operators on appropriate actions that should be taken in response to the alarm.
3. Alarms should not be used to identify normal operating conditions. Alarm set points should reflect the current operating condition of the plant under routine operation.
4. Parameters or equipment that are in an alarm state should be highlighted on any overviews or system mimics.
5. Alarms should not be used for information only alerts. Information that does not require an immediate operator action or provide operationally relevant information should not produce an alarm.
6. Alarms presented on a list should be prioritized and should provide the operator with an easy method of searching and sorting based on priority.

3.11.2 Technical basis

Alarm Management/Event Diagnosis has become a key priority for U.S. nuclear power plants (Thomas et al. 2010). It has become a pressing need to:

“...replace the current alarm systems (annunciators, alarm logs, status lights, bi-stable indications, etc.) with an event diagnostic system and an audible announcement capability for plant events (as

opposed to alarms based on symptoms). A system such as this would more quickly take operators to the needed recovery actions (if not automatically executed) relative to the time it now takes to work through symptom-based procedures. An intelligent alarm system could also prioritize alarms, presenting critical alarms for the given event and suppressing inconsequential alarms, to reduce the information overload on the control room.”

This remains an important vision that is likely to form a key component of the modernization strategies of utilities and it is with this vision in mind that INL intends to embark on an exploration of first-principle research for modern alarm system presentation. It is anticipated that lessons learned from current best practice in other industries will be an important contributor to human factors research under the control room modernization project of the II&C pathway.

With extended life ahead of them and the inevitable obsolescence of existing systems, asset owners and plant operators are looking to modernize their instrumentation and control systems. The control room modernization project has created a unique opportunity to address the human factors challenges of new alarm systems. However, researchers will find that there is no one size fits all design standard for NPP control rooms. Instead there are general principles that should be understood, controlled and optimized in every control room. These principles are covered extensively in the literature referenced below, but the main objective of the planned research is still to develop technical basis, or at least provide some empirical evidence, for the most salient aspect of modern alarm system design.

The following concepts are extracted from an alarm specification developed for a gas-cooled reactor (Hugo, 2008). These concepts were based on a combination of company policy, engineering judgment, industry best practice, and established standards and guidelines:

- The alarm system shall be explicitly designed to take account of human factors and limitations. The design should ensure that the alarm system remains usable in all process conditions, by ensuring that unacceptable demands are not placed on operators by exceeding their perceptual and cognitive capabilities.
- Perceptual factors - there are limitations on the ability of the human brain to take in information. The perception of information requires a certain amount of time, and we can only hold about 7 ± 2 units of information at the same time. (For example, having to remember an equipment ID number approaches the upper limit of working memory). Because of this it is important that, for all credible accident scenarios, the designer should demonstrate that the total number of safety related alarms and their maximum rate of presentation does not overload the operator.
- Cognitive factors - when several units of information can be combined into one single meaningful representation (i.e. an aggregated alarm), the brain capacity required for handling this particular information will be reduced, and the brain will be able to handle more information effectively. The brain also has other facilities that helps increase the capacity of perception, which can be supported by information that is intuitively understood and pattern recognition in the information presented. For example, displaying alarms in a 3 x 3 visual pattern helps the operator to exploit his pattern recognition abilities and thus to recognize the nature of the alarms at a glance.
- Actions - any claims made for operator action in response to alarms must be based upon sound human performance data and principles. The alarm system should be adapted to the operator's defined tasks, identified and described through systematic task analysis.
- The alarm system should be context sensitive - alarms should be designed so that they are worthy of operator attention in all the plant states and operating conditions in which they are displayed.
- The alarm system must be properly documented, and clear roles and responsibilities must be established for maintaining and improving the system.

- Performance requirements to the alarm system should be defined to ensure that the alarm system is useful to the operators in all relevant operational situations. To meet the requirements performance monitoring should serve as input to the process of improving the alarm system.
- There should be an administrative system for handling access control and documentation of changes made to the alarm system. The administrative system should prevent unauthorized modifications to the system and ensure that all changes are traceable and properly documented.
- The alarm system must be fault tolerant - a fault tolerant system ensures that safety critical information is always available to the operators, both in normal operation and in emergency situations.
- System response time must not exceed 2 seconds. Short system response times are essential for the system to remain useful in critical situations with high demands on operators.
- Safety critical functions should be identified and documented. Status information and failure alarms from these functions should be clearly presented and continuously visible on dedicated displays. If safety critical functions are degraded or threatened, operators should be immediately alerted due to the possible consequences of such failures.
- Status information related to safety system functions, such as blocking/inhibit and override, must be easily available on dedicated lists and in process displays.
- Every alarm that is triggered should require acceptance - the operator should be required to accept each alarm to confirm that the alarm message has been read and understood. An alternative practice is that the operator will accept an alarm only when the associated response has been carried out. The operation and alarm philosophy should describe whether an alarm should be accepted after it has been read or after it has actually been dealt with.
- Navigation in alarm displays should be quick and easy - this is to support effective operator response to alarms by allowing quick navigation to additional information. For example, it should be possible to navigate from the alarm lists to the process display where the alarm is shown. A minimum number of operator interactions should be required to do this. It should also be possible to interrogate (e.g. right-click) an alarm in any display to get more information about it, such as alarm response procedures.

4. CONCLUSIONS

The evaluation activities validated the many of concepts in the original design philosophy and informed modifications to several elements. In general, the evaluation supported that use of overviews with simplified process mimics and embedded control. Qualitative input from interviews yielded criteria for deciding when mimics are an appropriate representation and identified several plant systems that should be presented as mimics. The operators accepted the dull screen approach to use of color, and the results from the evaluation activities were consistent with reserving saturated color for alarms and other dynamic information. The results from the activities also supported the use of embedded trends, alarms, and controls. The activities highlighted a lack of consensus among operators on where controls should appear on the screen, auxiliary operators (those that would likely interact with the LRS) seemed to prefer controls appear next the component they were controlling, and did not seem to be concerned about the control faceplate covering information on the mimic. Control room operators preferred having the control faceplate appear in a dedicated location, and noted that the control should not cover the information on the mimic. This discrepancy may be due to the dynamics of working on the LRS versus the control room (i.e., control room operator may deal with more fast evolving situations and may need to make decisions about system response before they have time to close a faceplate. Further research should identify the universal approach to location of control faceplates to resolve this discrepancy. The results from the liquid radiological waste activities will be implemented in a final liquid radiological waste control room concept, and the design philosophy will be adapted and applied to upgrades in the main control room.

5. REFERENCES

1. ANSI/ISA. (2015). *Human Machine Interfaces for Process Automation Industries (ANSI/ISA-101.01)*. Research Triangle Park, NC: International Society of Automation.
2. Boring, R., Hugo, J., Thomas, K., Ulrich, T., Le Blanc, K., Lew, R., & Medema, H. (2016). *Preliminary Concept for a Modernized Control Room at Palo Verde Nuclear Generating Station. (INL/INL/LTD-16-38483)*. Idaho National Laboratory.
3. Braseth, A., Nihlwing, C., Svengren, H., Veland, Ø., Hurlen, L., & Kvalem, J. (2009). Lessons learned from Halden project research on human systems interfaces. *Nuclear engineering and technology*, 41(3).
4. EPRI. (2015). *Human Factors Guidance for Control Room and Digital Human System Interface Design and Modification: Guidelines for Planning, Specification, Design, Licensing, Implementation, Training, Operation, and Maintenance for Operating Plants and New Builds*. TR-3002004310. Electric Power Research Institute.
5. Field, A., Miles, J., & Field, Z. (2012). *Discovering statistics using R*. Sage publications.
6. Grier, R. A. (2015, September). How high is high? A meta-analysis of NASA-TLX global workload scores. In *Proceedings of the Human Factors and Ergonomics Society Annual Meeting (Vol. 59, No. 1, pp. 1727-1731)*. Sage CA: Los Angeles, CA: SAGE Publications.
7. Ha, J. (2014). A Human-Machine Interface Evaluation Method Based on Balancing Principles. *4th DAAAM International Symposium on Intelligent Manufacturing and Automation*. 69, pp. 13-19. Procedia Engineering.
8. Hollified, B., Nimmo, I., Oliver, D., & Habibi, E. (2008). *The High Performance HMI Handbook*. Plant Automation Services.
9. Hugo, J. (2008). *Alarm System: Human Factors Requirements Specification (Unpublished Project Report)*. Pretoria, South Africa: PBMR (Pty) Ltd.
10. IEEE. (1998). *IEEE Guide for the Application of Human Factors Engineering in the Design of Computer-Based Monitoring and Control Displays for Nuclear Power Generating Stations. (International Standard No. IEEE 1289-1998)*. New York, NY: The Institute of Electrical and Electronics Engineers, Inc.
11. Kovesdi, C.R., Hill, R., Oxstrand, J., Spielman, Z., Le Blanc, K., & Hansen, T. (2017). *Prototype Design, Analysis, and Results for a Liquid Radiological Waste Control Room (INL/EXT-17-43226)*. Idaho National Laboratory.
12. Kovesdi, C.R., Rice, B., Bower, G., Spielman, Z., Hill, R., & Le Blanc, K. (2015). *Measuring Human Performance in Simulated Nuclear Power Plant Control Rooms Using Eye Tracking (INL/EXT-15-37311)*. Idaho National Laboratory.
13. Lau, N., Jamieson, G. A., Skraaning Jr., G., & Burns, C. M. (2008). Ecological Interface Design in the nuclear domain: An empirical evaluation of ecological displays for the secondary subsystems of a boiling water reactor plant simulator. *IEEE Trans. Nuclear Science*, 55(6), 3597-3610.
14. Le Blanc, K., Boring, R.L., Joe, J., Hallbert, B., & Thomas, K. (2014). *A Research Framework for Demonstrating Benefits of Advanced Control Room Technologies (INL-EXT-14-33901)*. Idaho National Laboratory.
15. Le Blanc, K., Hugo, J., Spielman, Z., Kovesdi, C.R., Hill, R., & Oxstrand, J. (2018). *Control Room Modernization End-State Design Philosophy. (INL/EXT-18-44798)*. Idaho National Laboratory.
16. Le Blanc, K., Kovesdi, C.R., Hill, R., Spielman, Z., Oxstrand, J., & Hansen, T. (2017). *Evaluation of Control Room Interface Designs to Support Modernization in Nuclear Power Plants (INL/EXT-17-43250)*. Idaho National Laboratory.
17. O'Hara, J., & Brown, W. (2002). *NUREG/CR-6690: The effects of interface management tasks on crew performance and safety in complex, computer-based systems, Vol. 2*. Washington, DC: Nuclear Regulatory Commission.

18. Rambally, G.K. & Rambally, R.S. (1987). Human factors in CAI design. *Computers & Education*, 11(2), 149-153. doi:10.1016/0360-1315(87)90009-1
19. Rasmussen, J., Pejtersen, A. M., & Goodstein, L. (1994). *Cognitive systems engineering*. New York: Wiley.
20. Stubler, W., O'Hara, J., & Kramer, J. (2000). *NUREG/CR-6635: Soft Controls: Technical Basis and Human Factors Review Guidance*. Washington, DC: Nuclear Regulatory Commission.
21. Thomas, K. D., Lipinski, F. P., Quinn, E., Hallbert, B., & Naser, J. (2010). Development of a new Working Group on Advanced Instrumentation, Control and Information System Technology for the LWR Sustainability Program. *Seventh American Nuclear Society International Topical Meeting on Nuclear Plant Instrumentation, Control and Human-Machine Interface Technologies (NPIC&HMIT 2010)*. Las Vegas: American Nuclear Society.
22. Tullis, T. & Albert, B. (2008). *Measuring the user experience: Collecting, analyzing, and presenting usability metrics*. Burlington, MA: Morgan Kaufmann.
23. U.S. Department of Defense (1983). *Human Engineering Design Criteria for Military Systems, Equipment and Facilities (MIL-STD 1472D)*. Washington, D.C.: U.S. Department of Defense.
24. U.S. Nuclear Regulatory Commission. (2002). NUREG-0700 (Rev. 2). *Human-system interface design review guidelines*. Washington, DC.
 - <http://www.nrc.gov/docs/ML0217/ML021700337.pdf>
 - <http://www.nrc.gov/docs/ML0217/ML021700342.pdf>
 - <http://www.nrc.gov/docs/ML0217/ML021700371.pdf>
25. U.S. Nuclear Regulatory Commission. (2012). NUREG-0711 (Rev. 3). *Human Factors Engineering Program Review Model*. Washington, DC.
 - <http://www.nrc.gov/reading-rm/doc-collections/nuregs/staff/sr0711/>
26. U.S. Department of Health and Human Services. (2018). Usability. gov. URL: <http://usability.gov>. Retrieved: www.usability.gov/what-and-why/information-architecture.html
27. Vicente, K. J. (2002). Ecological interface design: Progress and challenges. *Human Factors*, 44, 62-78.
28. Wickens, C. D., Gordon, S. E., Liu, Y., & Lee, J. (2003). *An introduction to human factors engineering (2nd Edition)*. Prentice-Hall, Inc., Upper Saddle River, NJ, USA.

6. APPENDICES

Appendix A: Table 11.1 of NUREG-0700

Table 11.1 Anthropometric data used to set limits for equipment dimensions

| Standing (without shoes) | Bounding Measurements (inches) | |
|--|------------------------------------|--|
| | 5 th %-ile Adult Female | 95 th %-ile Adult Male ¹ |
| Stature | 60.0 | 73.5 |
| Eye height from floor | 55.5 | 68.6 |
| Shoulder height | 48.4 | 60.8 |
| Elbow height | 37.4 | 46.8 |
| Fingertip height ² | 24.2 | 28.8 |
| Functional reach ³ | 25.2 | 35.0 |
| Extended functional reach ⁴ | 28.9 | 39.0 |
| Central axis of body to leading edge of console ⁵ | 5.0 | 5.3 |
| Eye distance forward of central axis to body ⁵ | 3.0 | 3.4 |
| Seated | Bounding Measurements (inches) | |
| | 5 th %-ile Adult Female | 95 th %-ile Adult Male ¹ |
| Popliteal height (bend at back of knee) | 15.0 | 19.2 |
| Sitting height above seat surface (erect) | 31.1 | 38.5 |
| Sitting height above seat surface (relaxed) | 30.5 | 37.6 |
| Eye height above seat, sitting erect | 26.6 | 33.6 |
| Shoulder height above seat surface | 19.6 | 25.8 |
| Elbow height above seat surface | 6.4 | 11.3 |
| Functional reach | 25.2 | 35.0 |
| Extended functional reach | 28.9 | 39.0 |
| Thigh clearance height | 4.1 | 7.4 |
| Buttock-popliteal length | 17.1 | 21.5 |
| Knee height | 18.5 | 23.6 |
| Central axis of body to leading edge of console ⁵ | 5.0 | 5.3 |
| Eye distance forward of central axis of body ⁵ | 3.0 | 3.4 |

(Source: MIL-STD-1472D, Section 5.6.)

¹ MIL-STD-1472D gives separate values for male troops and aviators. The two were averaged for presentation here.

² Data for male aviators only, 5th and 95th percentiles.

³ Measured from wall to tip of right index finger, with arm extended horizontal to floor, both shoulders against wall.

⁴ Measured as stated above, except right shoulder extended as far as possible with left shoulder against wall.

⁵ These measurements are not given in MIL-STD-1472D. Values provided in Seminara et al. are presented although they are based on measures of a different population. Differences in other measurements between the MIL-STD population and the EPRI population are small enough that these EPRI values should provide reasonable approximations.

Appendix B: Table 13 of MIL-STD-1472D

TABLE XIII. STANDING BODY DIMENSIONS

| | PERCENTILE VALUES IN CENTIMETERS | | | | | |
|--------------------------------|----------------------------------|----------|-------|-----------------|----------|-------|
| | 5th PERCENTILE | | | 95th PERCENTILE | | |
| | GROUND TROOPS | AVIATORS | WOMEN | GROUND TROOPS | AVIATORS | WOMEN |
| WEIGHT (kg) | 55.5 | 60.4 | 46.4 | 91.8 | 96.0 | 74.5 |
| STANDING BODY DIMENSIONS | | | | | | |
| 1 STATURE | 162.8 | 164.2 | 152.4 | 185.6 | 187.7 | 174.1 |
| 2 EYE HEIGHT (STANDING) | 151.1 | 152.1 | 140.9 | 173.3 | 175.2 | 162.2 |
| 3 SHOULDER (ACROMIALE) HEIGHT | 133.6 | 133.3 | 123.0 | 154.2 | 154.8 | 143.7 |
| 4 CHEST (NIPPLE) HEIGHT * | 117.9 | 120.8 | 109.3 | 136.5 | 138.5 | 127.8 |
| 5 ELBOW (RADIALE) HEIGHT | 101.0 | 104.8 | 94.9 | 117.8 | 120.0 | 110.7 |
| 6 FINGERTIP (DACTYLION) HEIGHT | | 61.5 | | | 73.2 | |
| 7 WAIST HEIGHT | 96.6 | 97.6 | 93.1 | 115.2 | 115.1 | 110.3 |
| 8 CROTCH HEIGHT | 76.3 | 74.7 | 68.1 | 91.8 | 92.0 | 83.9 |
| 9 GLUTEAL FURROW HEIGHT | 73.3 | 74.6 | 66.4 | 87.7 | 88.1 | 81.0 |
| 10 KNEECAP HEIGHT | 47.5 | 46.8 | 43.8 | 58.6 | 57.8 | 52.5 |
| 11 CALF HEIGHT | 31.1 | 30.9 | 29.0 | 40.6 | 39.3 | 36.6 |
| 12 FUNCTIONAL REACH | 72.6 | 73.1 | 64.0 | 90.9 | 87.0 | 80.4 |
| 13 FUNCTIONAL REACH, EXTENDED | 84.2 | 82.3 | 73.5 | 101.2 | 97.3 | 92.7 |
| | PERCENTILE VALUES IN INCHES | | | | | |
| WEIGHT (lb) | 122.4 | 133.1 | 102.3 | 201.9 | 211.6 | 164.3 |
| STANDING BODY DIMENSIONS | | | | | | |
| 1 STATURE | 64.1 | 64.6 | 60.0 | 73.1 | 73.9 | 68.5 |
| 2 EYE HEIGHT (STANDING) | 59.5 | 59.9 | 55.5 | 68.2 | 69.0 | 63.9 |
| 3 SHOULDER (ACROMIALE) HEIGHT | 52.6 | 52.5 | 48.4 | 60.7 | 60.9 | 56.6 |
| 4 CHEST (NIPPLE) HEIGHT * | 46.4 | 47.5 | 43.0 | 53.7 | 54.5 | 50.3 |
| 5 ELBOW (RADIALE) HEIGHT | 39.8 | 41.3 | 37.4 | 46.4 | 47.2 | 43.6 |
| 6 FINGERTIP (DACTYLION) HEIGHT | | 24.2 | | | 28.8 | |
| 7 WAIST HEIGHT | 38.0 | 38.4 | 36.6 | 45.3 | 45.3 | 43.4 |
| 8 CROTCH HEIGHT | 30.0 | 29.4 | 26.8 | 36.1 | 36.2 | 33.0 |
| 9 GLUTEAL FURROW HEIGHT | 28.8 | 29.4 | 26.2 | 34.5 | 34.7 | 31.9 |
| 10 KNEECAP HEIGHT | 18.7 | 18.4 | 17.2 | 23.1 | 22.8 | 20.7 |
| 11 CALF HEIGHT | 12.2 | 12.2 | 11.4 | 16.0 | 15.5 | 14.4 |
| 12 FUNCTIONAL REACH | 28.6 | 28.8 | 25.2 | 35.8 | 34.3 | 31.7 |
| 13 FUNCTIONAL REACH, EXTENDED | 33.2 | 32.4 | 28.9 | 39.8 | 38.3 | 36.5 |

*BUSTPOINT HEIGHT FOR WOMEN

Appendix C: Table 10.2 and Figure 10.3 from Wickens et al. (2003)

TABLE 10.2 Anthropometric Data (unit: inches)

| Measurement | Males | | Females | | Population Percentiles, 50/50 Males/Females | | |
|--|-----------------|----------|-----------------|----------|---|--------|--------|
| | 50th percentile | ± 1 S.D. | 50th percentile | ± 1 S.D. | 5th | 50th | 95th |
| | Standing | | | | | | |
| 1. Forward Functional Reach | | | | | | | |
| a. includes body depth at shoulder | 32.5 | 1.9 | 29.2 | 1.5 | 27.2 | 30.7 | 35.0 |
| | (31.2) | (2.2) | (28.1) | (1.7) | (25.7) | (29.5) | (34.1) |
| b. acromial process to functional pinch | 26.9 | 1.7 | 24.6 | 1.3 | 22.6 | 25.6 | 29.3 |
| c. abdominal extension to functional pinch | (24.4) | (3.5) | (23.8) | (2.6) | (19.1) | (24.1) | (29.3) |
| 2. Abdominal Extension Depth | 9.2 | 0.8 | 8.2 | 0.8 | 7.1 | 8.7 | 10.2 |
| 3. Wrist Height | 41.9 | 2.1 | 40.0 | 2.9 | 37.4 | 40.9 | 44.7 |
| | (41.3) | (2.1) | (38.8) | (2.2) | (35.8) | (39.9) | (44.5) |
| 4. Tibial Height | 17.9 | 1.1 | 16.5 | 0.9 | 15.3 | 17.2 | 19.4 |
| 5. Knuckle Height | 29.7 | 1.6 | 28.0 | 1.6 | 25.9 | 28.8 | 31.9 |
| 6. Elbow Height | 43.5 | 1.8 | 40.4 | 1.4 | 38.0 | 42.0 | 45.8 |
| | (45.1) | (2.5) | (42.2) | (2.7) | (38.5) | (43.6) | (48.6) |
| 7. Shoulder Height | 56.6 | 2.4 | 51.9 | 2.7 | 48.4 | 54.4 | 59.7 |
| | (57.6) | (3.1) | (56.3) | (2.6) | (49.8) | (55.3) | (61.6) |
| 8. Eye Height | 64.7 | 2.4 | 59.6 | 2.2 | 56.8 | 62.1 | 67.8 |
| 9. Stature | 68.7 | 2.6 | 63.8 | 2.4 | 60.8 | 66.2 | 72.0 |
| | (69.9) | (2.6) | (64.8) | (2.8) | (61.1) | (67.1) | (74.3) |
| 10. Functional Overhead Reach | 82.5 | 3.3 | 78.4 | 3.4 | 74.0 | 80.5 | 86.9 |
| Seated | | | | | | | |
| 11. Thigh Clearance Height | 5.8 | 0.6 | 4.9 | 0.5 | 4.3 | 5.3 | 6.5 |
| 12. Elbow Rest Height | 9.5 | 1.3 | 9.1 | 1.2 | 7.3 | 9.3 | 11.4 |
| 13. Midshoulder Height | 24.5 | 1.2 | 23.8 | 1.0 | 21.4 | 23.6 | 26.1 |
| 14. Eye Height | 31.0 | 1.4 | 29.0 | 1.2 | 27.4 | 29.9 | 32.8 |
| 15. Sitting Height, Normal | 34.1 | 1.5 | 32.2 | 1.6 | 32.0 | 34.6 | 37.4 |
| 16. Functional Overhead Reach | 50.6 | 3.3 | 47.2 | 2.6 | 43.6 | 48.7 | 54.8 |
| 17. Knee Height | 21.3 | 1.1 | 20.1 | 1.9 | 18.7 | 20.7 | 22.7 |
| 18. Popliteal Height | 17.2 | 1.0 | 16.2 | 0.7 | 15.1 | 16.6 | 18.4 |
| 19. Leg Length | 41.4 | 1.9 | 39.6 | 1.7 | 37.5 | 40.5 | 43.9 |
| 20. Upper-Leg Length | 23.4 | 1.1 | 22.6 | 1.0 | 21.1 | 23.0 | 24.9 |
| 21. Buttocks-to-Popliteal Length | 19.2 | 1.0 | 18.9 | 1.2 | 17.2 | 19.1 | 20.9 |
| 22. Elbow-to-Fit Length | 14.2 | 0.9 | 12.7 | 1.1 | 12.6 | 14.5 | 16.2 |
| | (14.6) | (1.2) | (13.0) | (1.2) | (11.4) | (13.8) | (16.2) |
| 23. Upper-Arm Length | 14.5 | 0.7 | 15.4 | 0.4 | 12.9 | 13.8 | 15.5 |
| | (14.6) | (1.0) | (13.3) | (0.8) | (12.1) | (13.8) | (16.0) |
| 24. Shoulder Breadth | 17.9 | 0.8 | 15.4 | 0.8 | 14.3 | 16.7 | 18.8 |

(continued)

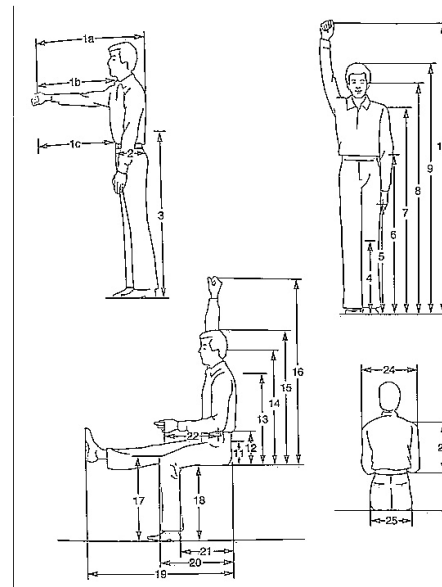

FIGURE 10.3
 Anthropometric measures: standing and sitting. (Source: Eastman Kodak Company, 1986. *Ergonomic Design for People at Work*, Vol. 1. New York: Van Nostrand Reinhold.)