

# Light Water Reactor Sustainability Program

## Complete Evaluation of ION Cost Reduction Opportunities for LWRS Program Pathways



September 2023

U.S. Department of Energy

Office of Nuclear Energy

**DISCLAIMER**

This information was prepared as an account of work sponsored by an agency of the U.S. Government. Neither the U.S. Government nor any agency thereof, nor any of their employees, makes any warranty, expressed or implied, or assumes any legal liability or responsibility for the accuracy, completeness, or usefulness, of any information, apparatus, product, or process disclosed, or represents that its use would not infringe privately owned rights. References herein to any specific commercial product, process, or service by trade name, trade mark, manufacturer, or otherwise, does not necessarily constitute or imply its endorsement, recommendation, or favoring by the U.S. Government or any agency thereof. The views and opinions of authors expressed herein do not necessarily state or reflect those of the U.S. Government or any agency thereof.

# Complete Evaluation of ION Cost Reduction Opportunities for LWRs Program Pathways

S. Jason Remer, Svetlana Lawrence, Craig A. Primer, and Richard D. Boardman  
Idaho National Laboratory

Doug M. Osborne  
Sandia National Laboratory

Xiang Chen  
Oak Ridge National Laboratory

Sean Lawrie, Luke Martin, Alex Tylecote, and Brian Szews  
ScottMadden

September 2023

Prepared for the  
U.S. Department of Energy  
Office of Nuclear Energy  
[Light Water Reactor Sustainability Program](#)

*Page intentionally left blank*

## **ABSTRACT**

The purpose and mission of the Integrated Operations for Nuclear Business Model and research effort at Light Water Reactors Sustainability (LWRS) Program is to identify and integrate technological and programmatic changes and modernizations to nuclear plant operations. These changes, called “work reduction opportunities,” are first advanced and integrated into the integrated operations for nuclear model then verified and explored further in applied ways with partnering utilities and plant sites.

As the integrated operations for nuclear model gains structure, researchers actively seek to incorporate new work reduction opportunities as components to the existing work reduction opportunities suite from ongoing research within the LWRS Program. To achieve this, each pathway in the LWRS Program was assessed, and interviews conducted with each pathway lead to gather insights into current and future research and development efforts that could contribute to the creation of new work reduction activities.

*Page intentionally left blank*

# CONTENTS

1.	INTRODUCTION .....	1
1.1	Plant Modernization Group.....	1
1.1.1	Modernization of Field-End Digital Infrastructure .....	2
1.1.2	Data Capture and Visualization .....	3
1.1.3	Integrating Artificial Intelligence and Machine Learning with Sensor Deployment.....	5
1.1.4	Use of Enterprise Data for Operational Decision-Making.....	6
1.1.5	Developing a Business Case Concerning the Economic Benefits of Reducing Maintenance Frequencies .....	7
1.2	Flexible Plant Operations and Generation (FPOG).....	8
1.2.1	Use of Nuclear Plants to Produce Hydrogen.....	8
1.2.2	Expansion of Steam Production and Accessing the Markets for Thermal Energy .....	10
1.2.3	Using Gasification to Turn Black Liquor into Fuel .....	11
1.3	Risk Informed Systems Analysis (RISA) .....	12
1.3.1	Risk-Informed Asset Management .....	12
1.3.2	Risk-Aligned Data-Driven Compliance.....	13
1.3.3	Evaluations of Accident-Tolerant Fuel (ATF) with Higher Burnup.....	14
1.3.4	Plant Reload Optimization .....	15
1.3.5	Risk Assessment of Digital I&C Systems.....	15
1.3.6	Enhanced Fire PRA.....	16
1.3.7	AI Supported LiDAR .....	17
1.3.8	Risk-Informed Aging Management and Subsequent License Renewal (SLR).....	17
1.4	Physical Security Group.....	18
1.4.1	Augmented Reality for Force-on-Force Exercises.....	19
1.4.2	Advanced Sensors Unique to Nuclear Power Plants.....	20
1.4.3	Performance Based Risk Informed Assessment for Security.....	20
1.4.4	Remote Operated Weapons.....	21
1.5	Materials Research .....	22
1.5.1	Predicting the Embrittlement Trend Curve for Reactor Pressure Vessels Under High Fluence Conditions in Extended Operations .....	23
1.5.2	Thermal Annealing of Reactor Pressure Vessel.....	24
1.5.3	Address Potential Concern of Stress Corrosion Cracking on a High Chromium and Nickel Based Alloy 690 .....	25
1.5.4	Replacing Lithium Hydroxide with Potassium Hydroxide for PWR Water pH Control .....	25
1.5.5	Concrete Performance / Degradation After Irradiation.....	26
1.5.6	Developing an Effective Cable Condition Monitoring Program .....	27
1.6	Summary Table .....	28
1.6.1	Observations .....	29
1.6.2	Areas for Growth .....	30
Appendix A Research Area Summary Materials Plant Modernization Group .....		31
Appendix B Flexible Plant Operations & Generation (FPOG).....		37
Appendix C Research Area Summary Materials Risk Informed Systems Analysis (RISA) .....		46

Appendix D Physical Security .....	53
Appendix E Materials Research.....	65
Appendix F Briefing Paper on Evaluation of ION Cost Reduction Opportunities for LWRS Program Pathways .....	71

## TABLES

Table 1. Results summary for Process Logic Controllers.....	3
Table 2. Results summary for Additional Field Sensors Data Visualization Software Data Analysis Software or Cloud Computing.....	4
Table 3. Results summary for Artificial Intelligence and Machine Learning Software. ....	6
Table 4. Results summary for Bi-directional Data Interrogator. ....	7
Table 5. Results summary for Incorporation of Risk of Failure Due to Maintenance. ....	8
Table 6. Results summary for Technology to Generate Hydrogen from Thermal or Electrical Power.....	10
Table 7. Results summary for Technology to Distribute Excess Thermal Energy Directly to Customers.....	11
Table 8. Results summary for Technology to Gasify Black Liquor. ....	12
Table 9. Results summary for Risk Informed Asset Management Software.....	13
Table 10. Results summary for Artificial Intelligence / Machine Learning. ....	14
Table 11. Results summary for Risk-informed Software Suite to Evaluate ATF Safety.....	15
Table 12. Results summary for Risk-informed Software Suite Digital I&C System Replacement program.....	16
Table 13. Results summary for Fire PRA Software Suite and Model. ....	17
Table 14. Results summary for LiDAR Plant Model Artificial Intelligence / Machine Learning.....	17
Table 15. Results summary for License Renewal Program Risk Informed Tools to Evaluate Aging Components.....	18
Table 16. Results summary for Augmented Reality Software and Programming Capability Augmented Reality Headsets and Hardware.....	19
Table 17. Results summary for Advanced Intrusion Detection Sensors.....	20
Table 18. Results summary for Probabilistic Risk Assessment Software and Techniques. ....	21
Table 19. Results summary for Remote Operated Weapon Systems.....	22
Table 20. Results summary for Charpy Impact Testing Embrittlement Curve (forthcoming). ....	23
Table 21. Results summary for Reactor Pressure Vessel Thermal Annealing.....	24
Table 22. Results summary for Alloy 690 Test Results.....	25
Table 23. Results summary for Potassium Hydroxide vs Lithium Hydroxide. ....	26
Table 24. Results summary for Guidelines for Irradiated Concrete. ....	27



Table 25. Results summary for Condition-Based Cable Monitoring Program ..... 28  
Table 26. Integrated summary results for all the research initiatives..... 28

## ACRONYMS

AI	artificial intelligence
AMP	aging management programs
ATF	accident tolerant fuels
CAS	central alarm station
CBS	concrete biological shield
CCNG	Combined Cycle Natural Gas
CWP	Circulating Water Pump
DARPA	Defense Advanced Research Projects Agency
EQ	Environmental Qualification
FPOG	Flexible Plant Operations and Generation
GALL	Generic Aging Lessons Learned
HTSE	high-temperature steam electrolysis
I&C	instrumentation and control
ION	integrated operations for nuclear
IRA	Inflation Reduction Act
LOCA	Loss of Coolant Accident
MI	machine learning
MSPI	Mitigating System Performance Index
MSR	molten salt reactors
NRC	U.S. Nuclear Regulatory Commission
O&M	operation and maintenance
PLC	Process Logic Controller
PRA	Probabilistic Risk Assessment
PWR	pressurized water reactor
R&D	research and development
RISA	Risk Informed Systems Analysis
SCC	stress corrosion and cracking
SLR	Subsequent License Renewal
SSCs	systems, structures, and components
VVER	water-water energy reactor
WRO	work reduction opportunities

# Complete Evaluation of ION Cost Reduction Opportunities for LWRs Program Pathways

## 1. INTRODUCTION

The Light Water Reactor Sustainability (LWRS) Program, sponsored by the U.S. Department of Energy (DOE) and coordinated through a variety of mechanisms and interactions with industry, vendors, suppliers, regulatory agencies, and other industry research and development (R&D) organizations, performs research to develop technologies and other solutions to improve economics and reliability, sustain safety, and extend the operation of nation's fleet of nuclear power plants.

The LWRS program has two objectives to maintain the long-term operations of the existing fleet:

1. To provide science and technology-based solutions to industry to implement technology to exceed the performance of the current business model; and
2. To manage the aging of systems, structures, and components (SSCs) so nuclear power plant licenses can be extended and the plants can continue to operate safely, efficiently, and economically.

The LWRS Program research and development pathways are:

- Plant Modernization – R&D to address nuclear power plant economic viability in current and future energy markets through innovation, efficiency gains, and business model transformation using digital technologies.
- Flexible Plant Operation and Generation – R&D to identify opportunities and develop methods for light-water reactors (LWRs) to directly supply energy to industrial processes to diversify approaches to revenue generation.
- Risk-Informed Systems Analysis – R&D to develop and deploy risk-informed tools and methods to achieve high levels of safety and economic efficiencies.
- Materials Research – R&D to develop the scientific basis for understanding and predicting long-term environmental degradation behavior of materials in nuclear power plants.
- Physical Security – R&D to develop methods, tools, and technologies to optimize and modernize a nuclear facility's security posture.

### 1.1 Plant Modernization Group

The Plant Modernization Pathway research and development efforts address critical gaps in technology development and deployment to reduce risk and cost. The objective of these efforts is to develop, demonstrate, and support the deployment of new digital I&C technologies for nuclear process control, enhance worker performance, and provide enhanced monitoring capabilities to ensure the continued safe, reliable, and economic operation of the nation's nuclear power plants.

New value from I&C technologies is possible if they are integrated with work processes, directly support plant staff, and are used to create new efficiencies and ways of achieving safety enhancements. A goal of these efforts is to motivate the development of a seamless digital environment for plant operations and support by integrating information from plant systems with plant processes for plant workers through an array of interconnected technologies:

- Plant systems – beyond centralized monitoring and awareness of plant conditions, deliver plant information to digitally based systems that support plant work and directly to workers performing these work activities.

- Plant processes – integrate plant information into digital field-work devices, automate many manually performed surveillance tasks, and manage risk through real-time centralized oversight and awareness of field work.
- Plant workers – provide plant workers with immediate, accurate plant information that allows them to conduct work at plant locations using assistive devices that minimize radiation exposure, enhance procedural compliance and accurate work execution, and enable collaborative oversight and support even in remote locations.

The development and collaborations through this pathway are intended to overcome the inertia that sustains the current status quo of today’s I&C systems technology and to motivate transformational change and a shift in strategy—informed by business objectives—to a long-term approach to I&C modernization that is more sustainable.

The following research initiatives capture current efforts to fulfill the objectives of the Plant Modernization Pathway within the LWRS Program

### **1.1.1 Modernization of Field-End Digital Infrastructure**

Implementation Timing: Project implementable in 3–5 years or Generation 1. See Table 1.

- Opportunity Description: Among the areas with the greatest work reduction opportunity from modernization is the replacement of existing analog field-end devices—which work within key systems such as pumps and pump motors—with field-end devices that have computing capabilities. These field-end devices may include pump motor sensors, motor controllers, and motor starters. Relevant field-end devices could also include process control such as skid-mounted conditioning units.
- Upgrade: The modernization consists of eliminating analog and mechanical safety logic functions, such as the start and trip logic, currently relayed within the component circuit breakers. These functions can be accomplished using a computing edge device such as a programmable Process Logic Controller (PLC). The PLC replaces the analog logic system within the breaker.

Further systems that could benefit from digital modernization include medium voltage switchgear and starters, which some companies have already modernized following a similar rationale as described above. The modernization of these systems has allowed for the elimination of all relay contacts.

- Advantages and Benefits: Modern digital systems have numerous advantages over analog and mechanical systems. While analog systems use predictive maintenance schedules and take up many technician man-hours to maintain, digital systems facilitate condition-based maintenance through their ability to auto-generate reporting of failures and internal parameters. Additionally, digital alternatives either do not require calibration or are automated by the device itself. Finally, analog systems contain numerous components which have high failure rates and require replacements that often cannot be easily or cheaply procured. Digital alternatives are solid-state systems that have no moving parts and therefore do not experience wear or mechanical failure.

- **Potential Savings:** Savings from the digital modernization of field-end devices will come from two sources. First, modernization will lead to full-time employment reductions in craft resources through reduced maintenance requirements on the analog logic components within component breakers. Preventative and non-repetitive maintenance will decrease because digital systems require fewer total man-hours to test and maintain. Digital components also eliminate man-hours consumed with calibration. Secondly, since the analog and mechanical control logic components will be replaced with a computing edge device, fewer overall components will be needed to service the system. This will lead to reduced material spending and abate cost escalation due to obsolescence or inflation.
- **Challenges:** The major challenge of digital modernization of field-end instruments is the high up-front capital investment costs of modernizing numerous field-end components. Economic modeling of similar—although less ambitious—modernization initiatives also point to relatively long payback periods. This makes them particularly sensitive to changes in certain modeling parameters such as discount rate variability.

Table 1. Results summary for Process Logic Controllers.

Technology Requirements	Cost Savings Type	Functions Impacted	Positions Impacted
Process Logic Controllers	Direct Labor Efficiency Gain	Maintenance	Craft Technicians

### 1.1.2 Data Capture and Visualization

Implementation Timing: Project implementable in 3–5 years or Generation 1. See Table 2.

- **Opportunity Description:** Modernization of data visualization capabilities and the utilization of dynamic dashboards provide considerable work reduction opportunities, especially combined with digital upgrades made to plant sensors. The development of a methodology for role-specific visualization allows for the curation and management of data in ways that allow for operational and efficiency improvements. Purposeful mapping of what, how, and by whom data is used means that the necessary data is collected, while not expending resources on the collection of data that serves no purpose. This data can be integrated using dynamic dashboards to allow for data to be presented in a way that is useful to the receiver.
- **Upgrade:** Dynamic dashboards are made effective by parametrizing real sensor data with the expected impacts of these variables on the component or system under observation. For example, understanding the likely condition of plant cables would require utilizing a dashboard with predictive capabilities for the impact of normal environment temperature and temperature variation above or below the normal range as a function of time. The dashboard could also include humidity, radiation exposure, and other relevant parameters impacting cable aging. This provides operators with dynamic estimates of the condition of the system and thereby determines the suitable time to carry out maintenance, and not before. This is known as “Preventive Maintenance Optimization.”

- **Advantages and Benefits:** Traditionally, maintenance is carried out according to predictive or periodic maintenance schedules based on an assumption of normal conditions, which leads to significantly shorter intervals between preventative maintenance activities. Operators must tend towards highly conservative estimates of component lifespans to avoid failures, especially for components that serve critical systems. Deferring maintenance using dynamic dashboards presents a significant work reduction opportunity as the preventative maintenance schedules can be adjusted based on the actual conditions of the components. Similar to condition-based maintenance, dashboards incorporate additional conditions present to the components and then bring each measurement to a specific dashboard just for that component. The data visualization could also incorporate analysis and amalgamation of a diverse array of readings to more accurately represent the condition within which the components are operating.

Using artificial intelligence (AI), preventive maintenance can be optimized and the intervals between maintenance significantly increase further. The integration of AI with dynamic data capture and visualization also provides superior intelligence and early warning capabilities, thereby reducing the probability of component failure. When this allows for the identification of those areas with elevated risk profiles, maintenance can be implemented to prevent system failure. This reduces the likelihood of costly component replacements as well as the potential for unplanned forced outages typically necessitating several days of lost generation revenue.

- **Potential Savings:** The use of dynamic dashboards and data visualization combined with the installation of relevant digital sensors allows plants to significantly reduce costs associated with preventative maintenance. Maintenance operations can be optimized through an up-to-date understanding of the condition of specific components and how those conditions affect the overall maintenance schedule. This enables workload reductions in craft labor.
- **Challenges:** Because there can be high costs associated with the installation of digital sensors in the plant, among the major challenges in the use of dynamic dashboards is the optimal deployment of sensors for outcomes that significantly reduce preventative maintenance. This requires considerable time in the planning phase of the implementation of the use case of each sensor installation to be economically justified.

Table 2. Results summary for Additional Field Sensors Data Visualization Software Data Analysis Software or Cloud Computing.

Technology Requirements	Cost Savings Type	Functions Impacted	Positions Impacted
Additional Field Sensors Data Visualization Software Data Analysis Software or Cloud Computing	Direct Labor Efficiency Gain	Maintenance Engineering	Craft Technicians Strategic Engineers

#### **1.1.2.1 An example of Data Capture and Visualization: Improved Use of Vibration Sensors in Circulating Water Pump (CWP) Systems**

- **Opportunity Description:** Progress has been made in finding work reduction opportunities using vibration sensors in an existing utility’s circulating water pump system and the effective analysis of the accompanying data in the plant process computer to prevent system failures. The improved utilization of the data has been achieved by connecting these sensors to the cloud, after having taken the necessary actions to ensure the cybersecurity effectiveness of both the wireless sensors and the cloud itself.

- Upgrade: The plant in question had been experiencing CWP failures which they had been unable to prevent with the existing configuration. Using the submerged vibration sensor, the plant extracted the indicator function data from the raw vibration signal which was stored in the plant process computer. Although the plant could not effectively store the raw vibration signal, raw indicator functions such as peak amplitude and the frequency of dynamic forces for the circulating water pump system could be effectively stored and used by the plant process computer. By analyzing vibration measurements, degradation issues such as imbalance, looseness, or misalignment can be identified at their onset.
- Advantages and Benefits: The ability to effectively analyze the raw indicator function data gives the plant operators more time to mount an effective response and implement actions to preempt significant failures. This technique is ready to be deployed across nuclear plants and implementing these improvements will be an important focus in the near term.
- Potential Savings: The savings from workload reductions in this project are limited by the scope of the system under consideration. However, demonstrating the effectiveness of using vibration sensor outputs provides use cases in other systems, such as the feedwater condensate system. In general, the savings for these use cases derive from extra generation revenue from preventing unplanned forced outages. There is also some potential for lower material spending through earlier maintenance on faults that preempt the need for component replacements.
- Challenges: A significant challenge, in this case, is negating the concerns of the utility associated with the implications of having complete dependence on a third party for the actionable analysis of the data.

### **1.1.3 Integrating Artificial Intelligence and Machine Learning with Sensor Deployment**

Implementation Timing: Project implementable in 3–5 years or Generation 1. See Table 3.

- Opportunity Description: The integration of AI and machine learning (ML) techniques with accessible and visualizable sensor data will allow for orders of magnitude higher realization of work reduction opportunities. The benefits that will flow from the effective use of AI and ML will be achieved on a plant-by-plant basis and are fundamentally a function of the ease of integrating these techniques by the plant operators into different safety and non-safety systems.
- Upgrade: A comprehensive ML approach for federated systems is being developed, moving from a simple model to a complex model that can assist operators in a multi-level class problem. To further develop the ML and AI models for CWP systems as an example, utilities were asked for the most frequent points of failure in their systems over the last 12 years. For each fault mode, a set of measurements were provided by the partner utilities. Some of these measurements overlapped with other faults and some were distinct for the fault in question. The failures were tracked in time and the pattern of parameter changes indicating a potential failure beforehand were recorded. These pattern changes, or signatures, were used to train the ML model to detect similar patterns and signals in the future and alert the users of a pending issue with the pump.

A major challenge for training the ML model in certain faults was the infrequency of specific failures over the period resulting in insufficient training and testing data for the model. In these cases, the challenge was overcome by “bootstrapping”; that is, creating artificial datasets with pre-populated fault signatures and parameters. Once the model is trained and tested on the artificial dataset as well as the actual dataset, it is locked, and real data is fed into it to test its accuracy.

A model developed using data from a single CWP system can be applied to other CWPs of different types either at the subject plant or other plants in the United States fleet with some minor adaptations. To do this, variable measurements that were used to build the initial model are mapped. In certain cases, specific measurements are missing, but this fact could be overcome so long as data are sufficient from other variables from which the ML model can generate the same outcomes.

Access to a national database containing information on all the CWP system parameters would improve the accuracy of the ML model. This is because CWPs are similar across U.S. nuclear plants with significant differences being seen only in their operating frequencies due to variation in the sources of cooling water in use at each plant. To develop an ML model with such a database, the sensor systems in place at each plant would be mapped and clustered according to the number and configuration of sensors on the motors and pumps. The operating speed of the pumps would also have been mapped to determine their frequencies. The model could then be trained on a defined set of parameters and applied to each additional CWP system. Models such as these which are built on multiple measures – known as “federated” or “transfer” learning - can be applied in different cases using only a small sample of data without losing reliability.

- **Advantages and Benefits:** Once a problem has been identified, complex ML models allow for fault data to be analyzed. This was previously extremely challenging because fault data signatures were so similar that it was difficult to pinpoint where the fault was developing. ML and AI modeling resolves this problem through its ability to integrate multiple separate measurements and parameters into one model which allows for the assignment of probability values for a particular fault. This informs the operator of the areas where further measurements should be manually sought to shed further light on the issue, provide confirmation as to its occurrence, and provide further insight into its cause. In other words, ML techniques allow operators to both pinpoint the area in which the faults are occurring and inform them as to the additional data which is missing. Finally, the probabilistic analysis which is generated from these techniques can be used in an economic equation to determine whether there is a financial rationale for carrying out maintenance or not.
- **Potential Savings:** Effective utilization of AI and ML as described above has the potential to lead to dramatic reductions in maintenance costs of all types and failure rates. AI and ML will likely enable workload reductions for craft labor and strategic engineers.
- **Challenges:** The largest potential for workload efficiency savings through the effective deployment of AI and ML exists in a plant’s safety systems. For ML to be effectively utilized to achieve workload reduction savings in safety systems, plant operators will first have to become skilled at using these techniques across non-safety systems and be comfortable with understanding and integrating the outputs from AI-generated analyses to alter maintenance operations. Moving forward, the use of AI and ML in safety systems may require the installation of additional sensors.

Table 3. Results summary for Artificial Intelligence and Machine Learning Software.

Technology Requirements	Cost Savings Type	Functions Impacted	Positions Impacted
Artificial Intelligence and Machine Learning Software	Direct Labor Efficiency Gain	Maintenance Engineering	Craft Technicians Strategic Engineers

#### 1.1.4 Use of Enterprise Data for Operational Decision-Making

Implementation Timing: Project implementable in 3–5 years or Generation 1. See Table 4.



- **Opportunity Description:** Another major work reduction opportunity is for the modernization of the data diode, which for security reasons currently only allows for one-directional data transfer from the plant to the business network and not vice versa. The replacement of the data diode style data transfer with a bi-directional system would allow for the data that exists on the business network to be brought “into the plant” and used for operational decision-making.
- **Upgrade:** The likely solution is the use of a “bi-directional interrogator” which is currently being developed by the Defense Advanced Research Projects Agency (DARPA). This system is thought to contain sufficient security capabilities for use in a nuclear plant.
- **Advantages and Benefits:** The use of enterprise data to inform operational decision-making would enable substantive advances in the deployment of automation in numerous plant activities and operational processes. Combined with the use of wireless and remote communications technology, bidirectionality allows for considerable additional flexibility, including remote management and remote performance of maintenance operations engineering and ASME testing by equipment vendors themselves.
- **Potential Savings:** Savings in this area are only hypothetical at this stage since reductions in workload associated with the automation of plant systems through the use of enterprise data have not yet been tangibly demonstrated or modeled. In general, automation is likely to lead to workload reductions associated with various types of maintenance activities, while increased access to enterprise data will provide operators (and others) the freedom to use the additional array of data sources to make decisions more quickly and with greater certainty.
- **Challenges:** Effective utilization of the bidirectionality of data flow to automate plant systems will likely require considerable numbers of manhours. The capital costs from the installation of new automated systems within the plant are likely to be high as well.

Table 4. Results summary for Bi-directional Data Interrogator.

Technology Requirements	Cost Savings Type	Functions Impacted	Positions Impacted
Bi-directional Data Interrogator	Direct Labor Efficiency Gain	Multiple	Multiple

### 1.1.5 Developing a Business Case Concerning the Economic Benefits of Reducing Maintenance Frequencies

Implementation Timing: Project implementable in 3–5 years or Generation 1. See Table 5.

- **Opportunity Description:** An area for additional research is investigating the reliability benefits of reducing the frequency and number of maintenance activities because of the risk associated with mistakes being made during the performance of these activities. Two studies from the University of Tennessee evaluate the quality of maintenance and the impact on reliability. Developing a model to evaluate the economic impacts of reducing the frequency of maintenance operations could be a valuable follow-up to this report.
- **Upgrade:** There are no tangible upgrades to be discussed at present.
- **Advantages and Benefits:** A business case would demonstrate which systems are likely to gain the most from digital upgrades because they suffer more from maintenance errors.

- **Potential Savings:** An economic analysis would model the additional savings from the non-occurrence of component failures from maintenance errors because of the modernization of plant systems.
- **Challenges:** The major challenge is obtaining reliable data on maintenance errors from which to build an effective economic analysis of the benefits of specific modernization efforts.

Table 5. Results summary for Incorporation of Risk of Failure Due to Maintenance.

Technology Requirements	Cost Savings Type	Functions Impacted	Positions Impacted
Incorporation of Risk of Failure Due to Maintenance	Direct Labor	Maintenance	Craft

## 1.2 Flexible Plant Operations and Generation (FPOG)

The purpose of the FPOG Pathway is to diversify and increase the revenue of LWRs in the U.S. This Pathway supports technical and economic assessments to raise the understanding of LWR owners, investors, utilities, and industrial manufacturing and transportation-sector industries. It supports essential R&D required to enable LWR plants to dispatch both thermal and electrical energy for the production of nonelectrical products through FPOG. This work focuses on interfaces between the LWR plant and the industrial-energy user that enable an LWR plant to optimize its revenue through the production of electricity and nonelectrical products. It addresses the potential safety hazards of collocated hydrogen and chemicals on operating licenses and system-integration interaction with LWR operations.

The following research initiatives capture current efforts to fulfill the objectives of the FPOG Pathway within the LWRS Program.

### 1.2.1 Use of Nuclear Plants to Produce Hydrogen

Implementation Timing: Project implementable in 3–5 years or Generation 1.

- **Opportunity Description:** Modifications to nuclear plants to support the production of hydrogen as an alternative revenue stream is the largest single opportunity area for workload optimization—if not workload reductions—being examined by the FPOG. Hydrogen production was targeted because of expectations for the rapid growth in demand for hydrogen, especially green and blue hydrogen. There are several potential options for how hydrogen produced from nuclear plants can be most effectively monetized which will depend on the exact configuration of the plant and the conditions of local industry for which hydrogen can be used as a feedstock. These include the production of synthetic fuels, cement, steel, and fuel cells. These options will be discussed in more detail in subsequent sections.
- **Upgrade:** There are two major upgrades or innovations required to allow hydrogen production to be economically viable at a nuclear plant. Firstly, the use of high-temperature steam electrolysis (HTSE) to produce hydrogen, is discussed below. Secondly, the ability of the plant to switch between servicing of electric grid load—when the wholesale electricity price makes this economically rational—and using a proportion of the plant’s output to produce hydrogen. A proportion of the plant’s thermal energy can be used to make the production of hydrogen more efficient. The challenges associated with varying the production of hydrogen in this way are discussed below.

- **Advantages and Benefits:** Nuclear plants have the potential to produce hydrogen with higher efficiency and less electricity consumption than comparable “green” processes through HTSE which utilizes excess thermal energy released from reactors, as well as electricity. The HTSE process dissociates steam at the cathode to form hydrogen molecules as well as oxygen ions. These migrate through the solid oxide electrolyte material to form oxygen molecules at the anode surface. This process is the reverse reaction to that of solid oxide fuel cell technology. HTSE requires about 35% lower electricity compared with conventional electrolysis at low temperatures. Overall, the current analysis estimates that HTSE processes have production efficiencies in excess of 50%, compared to ~40% for water electrolysis.
- **Potential Savings:** As mentioned, the production of hydrogen using HTSE is more efficient than conventional electrolysis. With the appropriate sizing of the hydrogen facility, the amount of thermal energy diverted from the nuclear plant to produce hydrogen would have a very marginal impact on the capacity factor of the nuclear plant. It is estimated that an optimal sizing of the hydrogen plant would use approximately 6% of the plant’s thermal energy. For a 1000 MW nuclear plant, there is approximately 3700 MW of heat. Economic modeling suggests that 100 MW of thermal energy would be diverted for hydrogen production. Using electricity to produce hydrogen instead of selling those electrons to the grid during periods in the day of low wholesale prices has the potential to lead to additional incremental revenue.
- **Challenges:** The major challenge of using incremental electrical and thermal energy from nuclear plants to produce hydrogen is associated with the regular powering off and on of the hydrogen plant (depending on the wholesale price of electricity for the nuclear plant).

The efficiency of the hydrogen production process will be impacted by non-constant electrical inputs. The detrimental effects on the production efficiency of the plant will have to be compared to other options, such as using a secondary source of electricity when not using electricity from the nuclear plant. The major problem with this alternative is the difficulty in assuring the green characteristics of this energy source, without which the economic viability of hydrogen production is in doubt. A possible solution is the installation of co-located battery storage.

As well as the efficiency of hydrogen production, another challenge of varying electricity inputs is that customers require a constant supply of hydrogen. In the case of production being non-constant, a “stock and flow” solution to assure a constant supply of hydrogen to the customer will be required through the installation of storage capacity. This adds incremental costs to any project.

Each location will have its optimal solution, depending on the specific characteristics of the site, including the localized marginal price of electricity. It will be a considerable challenge to model all the relevant variables to achieve the optimal solution in terms of the size of the hydrogen plant, the size of the storage facility, and whether the hydrogen refinery uses an alternative power source.

### **1.2.1.1 Customers for Hydrogen**

A major consideration in determining the viability of using existing nuclear plants to produce hydrogen is the proximity or potential proximity of customers for the hydrogen. Among the potential customers for nuclear-produced hydrogen are refineries, ammonia plants, steel manufacturers, and fuel cell vehicles.

Synthetic fuels are another promising option for a potential customer for hydrogen. To make this a viable use case, however, a source of carbon is required. Among the most economical and plentiful sources of CO<sub>2</sub> is from corn ethanol plants. Combined Cycle Natural Gas (CCNG) is also an economical source of CO<sub>2</sub>. An additional method is using the Fischer-Tropsch process, which converts carbon monoxide and hydrogen into liquid hydrocarbons.

Finally, renewable fuel refineries are another potential customer for HTSE-produced hydrogen. In states with Low Carbon Fuel Standards, such as California, there are predictable cash-flows for reductions in the carbon intensity of the fuel through.

### 1.2.1.2 *Upgrading*

Upgrading nuclear plants is another option that may be available to nuclear operators as a source of thermal power for hydrogen production. Typically, upgrading the nuclear plant to increase the size of the electrical output sold onto the grid is limited by the capacity of the turbine, which is prohibitively expensive to upgrade. An additional economic opportunity from upgrading the plant for hydrogen production is through investment tax credits provided through the Inflation Reduction Act (IRA). A 10% upgrading of a 1 GW nuclear plant could provide 50–60 tons of hydrogen per day.

### 1.2.1.3 *Electrolysis of Methane to Produce Hydrogen and Ethylene*

Another process that may be economically viable is the electrolysis of methane which creates hydrogen and ethylene, from which polymers can be created. However, many companies have investigated this opportunity and found that without a very cheap source of power, it is not viable. A potential means of making this economical would be if the renewable nature of the polymer could be effectively monetized. See Table 7.

Table 6. Results summary for Technology to Generate Hydrogen from Thermal or Electrical Power.

Technology Requirements	Cost Savings Type	Functions Impacted	Positions Impacted
Technology to Generate Hydrogen from Thermal or Electrical Power	Revenue Generation	N/A	N/A

## 1.2.2 **Expansion of Steam Production and Accessing the Markets for Thermal Energy**

Implementation Timing: Project implementable in over 5 years or Generation 2. See Table 7.

- **Opportunity Description:** Another potential opportunity is in accessing the market for thermal energy (steam), particularly the high demand for thermal energy from petrochemical refineries. An economic analysis has been carried out for selling steam to a refinery within 20 miles of an existing nuclear plant and has been demonstrated as viable. The refinery and the nuclear plant are currently in negotiations over a steam purchase agreement.
- **Upgrade:** Expansion of thermal energy offtake beyond the limited scope requires considerable modification to plant infrastructure, as discussed in more detail below.
- **Advantages and Benefits:** As with the previous discussions on the use of thermal energy, the advantage of steam as a potential revenue stream is that power stations can increase their production of thermal energy without requiring costly upgrades to turbines. Additionally, there are limited environmental concerns with citing pipelines for the transport of thermal energy, and siting is also not problematic.
- **Potential Savings:** Thermal energy offtake allows for access to large incremental revenue streams. The economic viability of large-scale thermal energy offtake is unclear at this point.
- **Challenges:** As mentioned earlier, there are challenges with the extraction of thermal energy from a nuclear plant, both in terms of its feasibility technically and viability economically. Recent research and development have been carried out in collaboration with architectural and engineering groups to understand the appropriate design of thermal extraction and the electrical connection with hydrogen plants. They also investigated effective dispatching mechanisms for operators and required upgrades to the control room.

In general, the research has attempted to determine the extent to which thermal extraction remains within the operating license basis and under which parameters. It is thought that the current consensus among the industry is if the steam extraction remains low, plants will stay within their operating license basis. It is generally agreed that the risks associated with limited extraction of thermal energy from nuclear plants are low. For larger plants with up to 1GW of thermal energy extraction, modifications would be much larger, risks would be elevated, and meeting regulations and licensing requirements would be far more strenuous and complicated.

Some studies have focused on analyzing thermal energy offtakes of up to 30% of total thermal production, and there is some disagreement over the risks and challenges at this scale. The capital costs of modifications at this level of thermal extraction are considerable. Most importantly, because plants have not been tested nor designed for this purpose, incremental risks associated with additional wear of the plant cannot be quantified. For this reason, it is suggested that thermal offtake projects begin on a small scale and only increase in scale after thorough observation of the effects on the plant infrastructure. Probabilistic risk assessments will need to be carried out thoroughly throughout every incremental modification.

A final challenge is the process by which the U.S. Nuclear Regulatory Commission (NRC) approval is obtained, as it is unclear at this stage at what level of plant modification a license amendment is required. If a plant can pass a 10 CFR 50.59 screening, no NRC approval or license amendment is likely to be necessary.

Table 7. Results summary for Technology to Distribute Excess Thermal Energy Directly to Customers.

Technology Requirements	Cost Savings Type	Functions Impacted	Positions Impacted
Technology to Distribute Excess Thermal Energy Directly to Customers	Revenue Generation	N/A	N/A

### 1.2.3 Using Gasification to Turn Black Liquor into Fuel

Implementation Timing: Project implementable in over 5 years or Generation 2. See Table 8.

- **Opportunity:** Another opportunity being explored is the use of hydrogen and thermal energy from nuclear power plants to gasify black liquor to convert it into a fuel source, which can be sold as biofuel or burnt to produce green electricity. In the pulp and paper industry, black liquor is a by-product of the process of digesting wood into pulp to produce paper. The pulp and paper industry is heavily concentrated in Georgia, and the southeast of the United States, in close proximity to a number of nuclear plants.
- **Upgrade:** Thermal energy and hydrogen produced by nuclear plants is used in the process of gasifying black liquor and turning it into fuel.
- **Advantages and Benefits:** Recovery boilers allow black liquor to be burnt to produce electricity. Burning black liquor in this way is less efficient than gasification and production of fuel. Additionally, many of these recovery boilers are old and will soon require replacing.
- **Potential Savings:** If the process of black liquor refining is situated close to a nuclear plant, the costs of hydrogen storage are dramatically reduced, and the costs of transporting hydrogen are virtually eliminated.
- **Challenges:** This initiative is in early development and its associated challenges have yet to be fully explored.

Table 8. Results summary for Technology to Gasify Black Liquor.

Technology Requirements	Cost Savings Type	Functions Impacted	Positions Impacted
Technology to Gasify Black Liquor	Revenue Generation	N/A	N/A

### 1.3 Risk Informed Systems Analysis (RISA)

The purpose of the RISA Pathway research and development is to support plant owner-operator decisions with the aim to improve the economics, and reliability, and maintain the high levels of safety of current nuclear power plants over periods of extended plant operations. The goals of the RISA Pathway are twofold:

- Deployment of methodologies and technologies that enable better representation of safety margins and the factors that contribute to cost and safety.
- Development of advanced applications that enable cost-effective plant operation.

The following research initiatives capture current efforts to fulfill the objectives of the Risk Informed Systems Analysis Pathway at LWRs.

#### 1.3.1 Risk-Informed Asset Management

Implementation Timing: Project implementable in 3–5 years or Generation 1. See Table 9.

- Opportunity Description: Deciding to repair a component or wait until the next available maintenance window can be a consequential and costly exercise. Risk-informed asset management aims to provide additional tools to managers and stakeholders that will generate better decisions using more data and the introduction of a risk profile to the component repair decision-making exercise.
- Risk-Informed Asset Management uses probabilistic risk assessment techniques to optimize component health and equipment reliability while at the same time lowering operation and maintenance (O&M) costs to the facility. One of the most consequential parameters of any component’s preventative maintenance schedule is the frequency of maintenance. Intuitively, decision-makers tend to believe that more maintenance is better. This philosophy is reinforced by vendors and vendor manuals. Vendor manuals favor more frequent maintenance since vendors cannot anticipate each component’s industrial application and they prefer a risk-averse approach. As a result, preventative maintenance intervals are conservatively established by the plant in the hopes of reducing the risk of pre-mature failure.
- Upgrade: Nuclear plants in the United States have gathered significant run-time, maintenance, and failure data on many nuclear power plant components. These figures can be used to generate information to help plant decision-makers when faced with significant decisions concerning preventative maintenance intervals. Risk-informed asset management considers industry-gathered run-time and failure data for classes of components and uses this data to inform plant-specific failure probabilities given that specific component’s working conditions, run-time, previous failures, maintenance history, and other parameters. In addition to observed failures and maintenance performed on equipment, live data is used (e.g., pressure, temperature) to understand the current equipment’s health condition. The integration of generic industry failure data, plant-specific failures, and maintenance history, and real-time monitoring data provides a complete picture of equipment’s current conditions and expected performance prognoses for the future (i.e., remaining useful life). The resulting output from risk-informed asset management can be expressed as a probability of component failure in the future or as a margin between the current state and undesired condition.

- **Advantages and Benefits:** With the incorporation of Risk-Informed Asset Management, leaders will have more information upon which to rely when making repair decisions. This data will help illuminate the risks of performing or not performing maintenance.

In a hypothetical scenario, by using risk-informed techniques, plants will be able to know that a particular component has a 10% chance of failure in the next eighteen months if maintenance is *not* performed in the upcoming outage and a 1% chance of failure if maintenance is performed in the upcoming outage. By presenting probabilities of failure based on probabilistic risk assessment techniques, the amount of risk will be quantified eliminating some of the guess work that goes into maintenance repair timing decisions. It will always remain the responsibility of plant engineers and other leaders to determine an acceptable level of failure risk and to consider other risks and consequences associated with the repair.

- **Potential Savings:** Savings associated with risk-informed asset management will vary based on the risk profile of the particular plant itself. Risk-averse plants may find smaller savings associated with deferred maintenance and less conservative plants have more savings. It is reasonable to state that for most plants using risk-informed asset management, maintenance will be deferred which will reduce parts costs and maintenance time associated with the activity. It is also possible, however, that risk-informed asset management will prevent plant trips and shutdowns since components with high failure probability rates will gain more maintenance attention.
- **Challenges:** Incorporating risk-informed asset management as a feature or component of condition-based maintenance is the next step in automating decision-making at nuclear plants. This same methodology can also be applied to engineering programs. Plants will have to become comfortable with the language and implications of this tool for it to be effective.

Table 9. Results summary for Risk Informed Asset Management Software.

Technology Requirements	Cost Savings Type	Functions Impacted	Positions Impacted
Risk Informed Asset Management Software	Direct Labor	Maintenance	Craft

### 1.3.2 Risk-Aligned Data-Driven Compliance

Implementation Timing: Project implementable in 3–5 years or Generation 1. See Table 10.

- **Opportunity Description:** Using artificial intelligence and machine learning to automate the corrective action program (previously captured in integrated operations for nuclear (ION) report INL/EXT-21-64134), regulatory and compliance activities, and equipment performance trends (see Section 1.1.3).

The condition report opportunity is covered in the ION Generation 1 suite of work reduction opportunities. It remains possible to apply similar techniques to compliance activities such as NRC/Institute of Nuclear Power Operations, reporting, maintenance rules, MSPI accounting, and other activities or programs required by regulators. In one example, artificial intelligence would be trained using the operator’s log history to automatically perform the MSPI time accounting task typically performed by engineers.

Operator logs contain the activities of operators throughout plant operation. Current MSPI time accounting techniques utilize operator logs and manually calculate instances of time when important safety systems, such as the emergency diesel, are being tested and therefore considered unavailable to perform their function. The total unavailability hours for the safety systems in question are then calculated and reported. Artificial intelligence could be trained to perform this task and then the results reviewed by an engineer prior to reporting to outside entities.

- Upgrade: Similar to the corrective action program, other regulatory reporting programs are also ripe for artificial intelligence treatment. With a large amount of pre-existing data, software intelligence can be trained to recognize, sort, calculate, and report meaningful plant parameters to management, regulators, and outside entities.
- Advantages and Benefits: Low-value work can be eliminated with the successful implementation of risk-aligned data-driven compliance. Much of the reporting and compliance work is simple time accounting, data tracking, compliance action reporting, and other regulatory and committed parameters.
- Potential Savings: Eliminating low-value work associated with regulatory and commitment reporting could save partial full-time equivalent time and produce a more efficient plant workforce. More research and time accounting would have to be performed to ensure enough hours are saved to make a meaningful difference in plant O&M spending.
- Challenges: Fully integrating artificial intelligence into any process requires accessible and understandable data from that particular function that will then be used to train the software. Generating a database of previous regulatory and compliance activities may be difficult going forward especially if that data is not in the format that can be accessed by artificial intelligence software. Regulators also may challenge the reliance on artificial intelligence when reporting regulatory commitments and metrics and could prefer human interaction to AI-generated reports.

Table 10. Results summary for Artificial Intelligence / Machine Learning.

Technology Requirements	Cost Savings Type	Functions Impacted	Positions Impacted
Artificial Intelligence / Machine Learning	Direct Labor Efficiency	Engineering Regulatory	Strategic Engineering Licensing

### 1.3.3 Evaluations of Accident-Tolerant Fuel (ATF) with Higher Burnup

Implementation Timing: Project implementable in 3–5 years or Generation 1. See Table 11.

- Opportunity Description: Per the NRC’s website, accident tolerant fuels (ATF) are a set of new technologies that have the potential to enhance safety at U.S. nuclear power plants by offering better performance during normal operation, transient conditions, and accident scenarios. ATF makes an existing commercial nuclear reactor more resistant to a nuclear incident (as defined in Section 11 of the Atomic Energy Act of 1954) and lowers the cost of electricity over the licensed lifetime of an existing commercial nuclear reactor.

This project aids in the performance of safety evaluations of accident-tolerant fuel and supports the approval of ATF for deployment to nuclear plants.

- Upgrade: ATF contains technology and materials upgrades such as coated cladding, doped pellets, FeCrAl cladding, increased enrichment, higher burnup, and longer-term technologies that all contribute to the multiple enhancements to plant safety and nuclear operation. This new fuel will require detailed analysis and nuclear fuel calculations for the plant considering its introduction. RISA project can help produce the safety assessments that will be needed to acquire permission from the NRC to implement accident-tolerant fuel.



- **Advantages and Benefits:** ATF is a different fuel design that has many advantages over existing fuel compositions. It is, as the name suggests, superior at resisting nuclear accident conditions and should be considered a nuclear safety improvement.

Accident-tolerant fuel is capable of remaining in the core longer than traditional fuel and as plants move from eighteen-month to twenty-four-month fuel cycles, this is a welcome technological upgrade. ATF is also capable of generating more energy from the core and as long as the downstream components are capable of handling the additional power, a power uprate may be available to certain plants.

Again, a more comprehensive approach including more detailed physics-based assessments and risk informed approaches to fuel design is a pathway for regulatory approvals and subsequent plant benefits from the fuel. With longer burnup and greater energy generation, the fuel could stay in the reactor for longer periods of time and generate more power and steam for the facility.

- **Potential Savings:** Savings from this pathway come from the implementation of accident-tolerant fuel itself. The research within the RISA pathway is a component of the process through which ATF can be analyzed and proven to be safe for any plant desiring to implement this technology. While there are multiple advantages to implementing ATF, the RISA component of its implementation is not directly correlated with power plant cost savings on its own and will only save on power plant capital costs when completing the project to implement the new fuel type.
- **Challenges:** Significant licensing changes are required to introduce ATF. Power uprates may not be possible as the safety and engineering limits of downstream components, including the turbine, may not have the margin necessary to accommodate the more powerful fuel.

Table 11. Results summary for Risk-informed Software Suite to Evaluate ATF Safety.

Technology Requirements	Cost Savings Type	Functions Impacted	Positions Impacted
Risk-informed Software Suite to Evaluate ATF Safety	Efficiency Fuel costs (new & spent)	Engineering Regulatory	Fuels Engineering Licensing

### 1.3.4 Plant Reload Optimization

Implementation Timing: Project implementable in 3–5 years or Generation 1.

- **Opportunity Description:** Using AI to assist in designing a core configuration and fuel requirements. This opportunity is similar in scope to AA-02 Reactor Core Design and Fuel Optimization in INL/EXT-21-64134.

### 1.3.5 Risk Assessment of Digital I&C Systems

Implementation Timing: Project implementable in 3–5 years or Generation 1. See Table 12.

- **Opportunity Description:** Develop an integrated platform for risk assessments of new and upgraded nuclear digital instrumentation and control (I&C) systems that support risk-informed approaches to upgraded safety and non-safety digital I&C system design, especially in the areas of common cause failures. Digital I&C systems can contain, in certain instances, triple redundant components to protect against failures and loss of function. Designs with greater redundancy are more expensive to implement due to additional material costs and labor to cover the redundant components.

- Upgrade: This opportunity can potentially realize a more efficient design through the use of probabilistic risk assessment tools and thereby streamline the number of components comprising existing nuclear safety-related digital I&C systems. Research would have to be established and viable in time for plants to take advantage during planned digital I&C upgrades where facilities are considering, or in the process of upgrading, I&C control systems from analog to digital for safety-related applications.
- Advantages and Benefits: This upgrade provides the potential to eliminate the requirement for diverse and redundant systems and components designed to mitigate the consequences of common-cause failures. These systems are, at times, designed to have triple redundancy and therefore contain many parts and sub-components that could be shown to be unnecessary using the tools of probabilistic risk analysis.
- Potential Savings: Savings could be achieved by implementing this analysis on a system-by-system basis. If successful, the assessments would show, through probabilistic risk analysis techniques, that redundant I&C digital components in the subject systems do not reduce the overall risk of core damage and are therefore unnecessary. This would allow the plant to consider abandoning the design of redundant digital components and only implement those systems and components that reduce the risk of system failure and core damage frequency.

Savings would be achieved during design and implementation in the form of fewer overall control system components. If the number of components that is reduced from the original design philosophy is significant, the reduction in the number of components will decrease the amount of material spent, installation labor, preventative maintenance, periodic testing, and technical support hours needed to keep them operational throughout the life of the new digital systems themselves.

- Challenges: It may be challenging to convince stakeholders, designers, and approvers that less redundancy is justified as this will seem like a reduction in overall nuclear safety. Probabilistic methods are not well known to the industry with many only exposed to them tangentially. Presenting the method, findings, and conclusions will have to be done with care and attention to these concerns from the industry.

Table 12. Results summary for Risk-informed Software Suite Digital I&C System Replacement program.

Technology Requirements	Cost Savings Type	Functions Impacted	Positions Impacted
Risk-informed Software Suite Digital I&C System Replacement program	Efficiency Direct Labor Materials	Engineering Installation labor Maintenance	Design Construction Craft

### 1.3.6 Enhanced Fire PRA

Implementation Timing: Project implementable in 3–5 years or Generation 1. See Table 13.

- Opportunity Description: Integration of a new tool (FRI3D or Fire Risk Investigation in 3D) that allows the user to dynamically model fire scenarios and view the results in three dimensions.
- Upgrade: Current industry-accepted fire modeling codes such as CFAST, FDS, Heat Soak, and THEIF are being integrated into the three-dimensional tool allowing users to better visualize fire hazards and fire scenarios.
- Advantages and Benefits: Benefits of the new fire modeling and simulation tool are improved fire scenario modeling, reduced conservatism usually imbedded in the traditional fire scenario assessments, generation of multiple ‘what-if’ scenarios quickly and easily, faster evaluations of plant modifications impacting the fire loading or fire protection designs, in-house utility evaluations of the fire PRA model and its changes without the necessity of hiring third party contractors and experts.

- Potential Savings: Most of the savings for this effort appear to be from saving contractor costs, especially for small changes that can be modeled in the three-dimensional tool. Other time savings and efficiencies appear smaller than one full-time equivalent per year.
- Challenges: Acquiring and learning the software plus gaining approval to utilize the software in fire protection scenarios.

Table 13. Results summary for Fire PRA Software Suite and Model.

Technology Requirements	Cost Savings Type	Functions Impacted	Positions Impacted
Fire PRA Software Suite and Model	Efficiency	Probabilistic Risk Assessment	Fire PRA

### 1.3.7 AI Supported LiDAR

Implementation Timing: Project implementable in 3–5 years or Generation 1. See Table 14.

- Opportunity Description: Connect LiDAR-generated three-dimensional models with plant component databases and use artificial intelligence to generate component tagging in the models.
- Upgrade: Plants do not typically have three-dimensional models of their facility. These models will be supplemental to existing design basis drawings, piping diagrams, layout drawings, and isometrics.
- Advantages and Benefits: Instead of sharing paper or pdf copies of design basis drawings, the three-dimensional model will allow plant workers to access the plant via the three-dimensional model to perform training activities, modeling scenarios like flooding and fire, plan maintenance and outage activities in areas that are not normally accessible while the plant is online, and other uses.
- Potential Savings: Efficiency gains are possible in the areas of PRA, system and design engineering, maintenance, planning, online and outage scheduling, and others. However, these savings are only achievable through the implementation of LiDAR itself or with plants that already have a LiDAR model of the plant. That model can then be analyzed using artificial intelligence to identify components and properly tag them. As such, the chances for savings through the implementation of AI-supported LiDAR are minimal.
- Challenges: Acquiring the software and equipment to model the plant and then generating the interface for users to access the model and make use of its features. Utilizing artificial intelligence to indicate tagging in the three-dimensional model seems potentially time-consuming.

Table 14. Results summary for LiDAR Plant Model Artificial Intelligence / Machine Learning.

Technology Requirements	Cost Savings Type	Functions Impacted	Positions Impacted
LiDAR Plant Model Artificial Intelligence / Machine Learning	Efficiency	Multiple	Multiple

### 1.3.8 Risk-Informed Aging Management and Subsequent License Renewal (SLR)

Implementation Timing: Project implementable in 3–5 years or Generation 1. See Table 15.

- Opportunity Description: Apply risk-informed approaches and techniques to the aging management of nuclear power plant components. The risk-informed analysis of aging systems will help engineers and others working on the license renewal project by showing the risk of failure of systems, structures, and components within the aging management program. This could delay the replacement or upgrade commitments of these components.

- **Upgrade:** Current aging management programs (AMPs) are entirely deterministic relying on very prescriptive requirements about how to monitor aging of the plant SSCs. The AMPs are described in NUREG-2191, Generic Aging Lessons Learned (GALL) for SLR referred to as the GALL-SLR report. The GALL report outlines specific inspections and testing as well as the intervals required to be performed for each type of SSCs as a way to demonstrate adequate performance. There is no connection made between SSC's importance to the overall plant safety and the requirements other than an implicit connection that all safety-related SSCs and SSCs that are part of various licensing commitments are to be included in the scope of the aging management programs. The risk-informed and performance-based approaches make explicit connections between an SSC or a system with the overall plant risk which allows to focus of plant efforts and resources on the important to safety SSCs. It also means that requirements for SSCs that are not important to the plant safety could be reduced resulting in cost savings. Given the large number of aging programs included in SLRs, the overall cost savings from the elimination of some of the requirements could be substantial.
- **Advantages and Benefits:** Probabilistic models generate values associated with a likelihood of failure over a given time as well as demonstrate consequences from equipment failures. This provides license renewal decision-makers and regulators with a better understanding of the risks of failure of a component or structure over the life of that component or structure. This additional information will help determine, in advance, the overall timing of component repair and reconditioning.
- **Potential Savings:** It appears possible to delay some license renewal repair and replacement requirements of components in the aging management program. This will be possible if the risk-informed analysis definitively shows that the probability of system, structure, or component failure remains very low throughout the additional years of life and if consequences to the plant's overall safety are minimal or non-existent. If possible, much savings can be realized by eliminating the necessity to repair, replace, upgrade, or modify nuclear power plant systems structures or components that are subject to aging but show a low risk of loss of function.
- **Challenges:** Gathering data that reflects the failures of aging components that can then be used in probabilistic analysis would be the greatest challenge. There is also a potential challenge in introducing the probabilistic methodology to regulators and other stakeholders in a convincing way to allow seemingly less conservative decisions to be made.

Table 15. Results summary for License Renewal Program Risk Informed Tools to Evaluate Aging Components.

Technology Requirements	Cost Savings Type	Functions Impacted	Positions Impacted
License Renewal Program Risk Informed Tools to Evaluate Aging Components	Direct Labor Materials Efficiency	Multiple	Multiple

## 1.4 Physical Security Group

The goal of the Physical Security Pathway is to develop and demonstrate an industry-wide strategy of sustaining a long-term, optimized, physical-security regime that reduces costs and regulatory burden. This research will leverage advances in technology such as advanced adversary-based risk-informed tools to reduce uncertainties in physical-security models used for planning and decision making. This research also aims to reduce conservatisms that affect current physical-security postures.

The following research initiatives capture current efforts to fulfill the objectives of the Physical Security Pathway within the LWRP Program.

### 1.4.1 Augmented Reality for Force-on-Force Exercises

Implementation Timing: Project implementable in 3–5 years or Generation 1. See Table 16.

- **Opportunity Description:** Force-on-force drills at nuclear plants require many resources including the hiring of outside contractors to act as adversaries who test the plant’s defenses. The security plan details all the measures required to eliminate any threat posed and must be verified through real-life scenarios. Training for a force-on-force drill can take time and is not usually achievable without the full participation of a significant proportion of the native security force as well as a trained and capable contract adversary. By delivering the force-on-force experience and scenario testing through augmented reality, officers and other security personnel can train for the full test without including a large contingent of nuclear security personnel.
- **Upgrade:** Current force-on-force exercises are delivered using third-party contractors who plan for and attack the plant site to test the security response and look for weak points in the defense. Nuclear security officers execute the security plan during the exercise while coordinating with the central alarm station (CAS) to eliminate the faux threat. These exercises are extensive and typically involve a full day of exercise time as well as multiple force-on-force training scenarios in preparation for the exercise.

Augmented reality technology allows plant security staff and management to deliver force-on-force style training to individual officers and recruits without involving the entire staff in a large and complex training exercise.

- **Advantages and Benefits:** Overall, utilizing augmented reality allows individual training for an assault on the plant and can be programmed to fit any number of different scenarios. Trainees will be able to receive instant feedback on their performance and can replay or retake the augmented reality scenario multiple times to ensure the best and most appropriate defensive tactics are utilized.
- **Potential Savings:** Savings are achievable in the reduction of full-force drilling at the plant site. While live-action security drills are, and always will be, necessary, defensive skills, tactics, and responses to an adversary can also be learned through the use of augmented reality. By doing so, officers new to the force who may not be as experienced as others have the chance to train on their own without involving the full contingent. Overall, the security force will be able to save training time and secure qualifications sooner with the help of augmented reality force-on-force training.
- **Challenges:** Familiarization with designing, programming, executing, and evaluating the results of an augmented reality force-on-force exercise will have to be learned by the security crew. Topics for training and scenarios are sensitive and may reveal security-related information so training content must be closely monitored. Third parties can assist but the security program risks reliance on an outside entity that may not be capable of viewing security-related information or opens the information to additional unsecure avenues.

Table 16. Results summary for Augmented Reality Software and Programming Capability Augmented Reality Headsets and Hardware.

Technology Requirements	Cost Savings Type	Functions Impacted	Positions Impacted
Augmented Reality Software and Programming Capability Augmented Reality Headsets and Hardware	Direct Labor	Security	Security Officer

### 1.4.2 Advanced Sensors Unique to Nuclear Power Plants

Implementation Timing: Project implementable in 3–5 years or Generation 1. See Table 17.

- **Opportunity Description:** Security is required to prevent unauthorized entry into the protected area of the nuclear plant. Entry points into the plant can include non-typical entryways such as intake canals, discharge canals, tunnels, and other pipelines, especially those that run underground or utilize waterways. It can be technically challenging to design and deploy sensors at these potential points of entry.
- **Upgrade:** Sensors specifically designed for nuclear power plants are a way to guard these access points without the need for the constant presence of a manned station or frequent foot patrols. Sensors can be connected to the central alarm station (CAS) and alert the CAS operator when a potential intrusion is in progress. Officers can then be sent to the area to intercept.
- **Advantages and Benefits:** The plant will benefit from a technological solution associated with difficult-to-guard points of entry and underwater intrusion pathways with the introduction of advanced sensors specifically designed for use at nuclear power plants. The technology will assist officers in intrusion detection and eliminate unhardened points of unwanted ingress.
- **Potential Savings:** The plant could produce savings in the form of fewer officers stationed at vulnerable points who are there to guard against an adversary intrusion. That function would be performed automatically by sensors specifically designed for these types of buildings and underwater pipelines. Sensors will alert officers in the alarm station who will then respond appropriately.
- **Challenges:** Design and installation of the sensor technology would present a challenge as there may be underwater work required as well as new and previously unused technology introduced to the plant staff and design engineering support. Maintenance can also become difficult if the sensors themselves are not designed in such a way as to allow ease of maintenance.

Table 17. Results summary for Advanced Intrusion Detection Sensors.

Technology Requirements	Cost Savings Type	Functions Impacted	Positions Impacted
Advanced Intrusion Detection Sensors	Direct Labor	Security	Security Officer

### 1.4.3 Performance Based Risk Informed Assessment for Security

Implementation Timing: Project implementable in 3–5 years or Generation 1. See Table 18.

- **Opportunity Description:** The typical security plan is developed and over time, revised to accommodate new threats and learnings from on-the-job experience. It contains plans to secure the site from the adversary including officer placement and movements, response timing, firing positions, expected adversary access points, and more. These plans are enhanced with the performance of force-on-force drills and other exercises that allow the security team to complete their mission of protecting the plant from a sabotage attack. Current plans rely on feedback from force-on-force drills and security expertise to develop potential intrusion scenarios. What these plans do not have at this time is a common performance-based risk-informed assessment methodology that can consider all the different intrusion and attack scenarios. Having this knowledge will allow security management to design the response to ensure the maximum number of officers are available to interdict and neutralize the most probable vectors.

- Upgrade: While the security plan is robust and accounts for all adversary intrusion scenarios, there may be efficiencies to gain by applying performance-based and risk-informed techniques and tools into the design of the plan itself. Consider an existing robust plan of interception of an adversary intrusion vector that, with implementation of performance-based risk-informed methods, may be shown to have an extremely small probability of success. This attack vector may have multiple officers stationed to prevent its occurrence despite its low probability of succeeding, and these officers could be deployed elsewhere and made ready to intercept a much more probable threat vector.
- Advantages and Benefits: Performance-based risk-informed security plans will show the probability of successful intrusion in certain scenarios and locations then allow security management and staff to utilize the limited resources of the security officer corps efficiently and effectively.
- Potential Savings: It is possible to utilize officer numbers more efficiently when the probabilities of successful intrusion are known to security staff. Low probability intrusion vectors can be de-emphasized, and higher likelihood intrusion paths strengthened. This will utilize the officer corps in a more efficient way and may lead to an overall reduction in the number of officers.
- Challenges: Access to the security plan is reserved for personnel with the clearance and need-to-know authorization. It might not be possible to have a full-time security risk assessor on staff within the site's security department, so outside experts will need to be relied upon. These resources may come from a corporate entity or utilize those employees at the plant proficient in performance-based risk-informed techniques and modeling. Outside help for generating a plan could be difficult given the nature of the sensitive information being analyzed. Also, each time the security plan is revised, the risk model will also need to be updated to reflect the change.

Table 18. Results summary for Probabilistic Risk Assessment Software and Techniques.

Technology Requirements	Cost Savings Type	Functions Impacted	Positions Impacted
Probabilistic Risk Assessment Software and Techniques	Direct Labor	Security	Security Officer

#### 1.4.4 Remote Operated Weapons

Implementation Timing: Project implementable in 3–5 years or Generation 1. See Table 19.

- Opportunity Description: Evaluations of remote-operated weapon systems in high-security areas demonstrate fields of view and lines of fire which can be achieved using these weapon platforms for external and internal deployment. The ability of an operator to move rapidly from weapon platform to weapon platform allows a single operator to cover assets and avenues of adversary approach across a large area in seconds. The system enables true force multiplication while allowing operators to maintain near immunity from attackers. The application of remote-operated weapon systems can allow sites to optimize responder numbers to the current threat level and even to new adversary capabilities while providing long-term cost savings. Due to the nature of the threat, remote-operated weapon systems are a compelling physical security force multiplier.
- Upgrade: Remote-operated weapon systems are designed to allow multiple operators to control the weapon platforms in a distributed, expandable, and standalone networked architecture. These operators coordinate lethal response through strategically located external and internal weapon platforms. Multiple weapon platform types can be integrated into the system and certified for operational use. These systems can be equipped with technologies such as daylight video cameras, thermal imagers for night operations, and a laser range finder. All these components, including the medium caliber rifle, could rotate 360-degrees and see 100s of meters. Officers in the CAS or other remote locations can control the weapon platforms.

- **Advantages and Benefits:** Remote-operated weapon systems take officers out of harm’s way, increase their survivability, and generate enough fire power interdict and neutralize adversaries. These systems are especially useful in isolated areas that require weapons in range of the target.
- **Potential Savings:** It is conceivable that multiple hours, potentially equating to a minimum of one officer, can be replaced with remote-operated weapons systems. These systems, if installed in the correct areas, eliminate manned guard posts and officer time in the field.
- **Challenges:** These systems have high upfront costs and will add additional training and maintenance activities to the security program which will also add to the O&M budget.

Table 19. Results summary for Remote Operated Weapon Systems.

Technology Requirements	Cost Savings Type	Functions Impacted	Positions Impacted
Remote Operated Weapon Systems	Direct Labor	Security	Security Officer

## 1.5 Materials Research

This pathway supports research and development to develop the scientific basis for understanding and predicting long-term environmental degradation behavior of materials in nuclear power plants. This work will provide data and methods to assess the performance of systems, structures, and components essential to safe and sustained nuclear power plant operations.

The Materials Research Pathway is involved in this research and development activity for the following reasons:

1. The Materials Research Pathway tasks provide fundamental understanding and mechanistic knowledge via science-based research. Mechanistic studies provide better foundations for prediction tool development and focused mitigation solutions. These studies also are complementary to industry efforts to gain relevant, operational data. The U.S. national laboratory and university systems are uniquely suited to provide this information given their extensive facilities, research experience, and specific expertise.
2. Selected Materials Research Pathway tasks are focused on the development of high-risk, high-reward technologies to understand, mitigate, or overcome materials degradation. This type of alternative technology research is uniquely suited for government roles and facilities. These pursuits also are outside the area of normal interest for industry sponsors due to the risk of failure.
3. The Materials Research Pathway tasks support collaborative research with industry and regulators (and meet at least one of the above objectives). The focus of these tasks is on supporting and extending industry capability by providing expertise, unique facilities, or fundamental knowledge.

Combined, these thrusts provide high-quality measurements of degradation modes, improved mechanistic understanding of key degradation modes, and predictive modeling capability with sufficient experimental data to validate these tools; new methods of monitoring degradation, and development of advanced mitigation techniques to provide improved performance, reliability, and economics.

The following research initiatives capture current efforts to fulfill the objectives of the Materials Research Pathway at LWRS.



### 1.5.1 Predicting the Embrittlement Trend Curve for Reactor Pressure Vessels Under High Fluence Conditions in Extended Operations

Implementation Timing: Project implementable in 5 or more years or Generation 2. See Table 20.

- **Opportunity Description:** A recent research initiative is focused on making improvements to the accuracy in predicting the rate of embrittlement of reactor pressure vessels when facing conditions of high fluence in PWRs over long periods of time through improvements in embrittlement trend curves. Existing models underestimate the rate of embrittlement of reactor pressure vessels under such high fluence conditions leading to embrittlement earlier than anticipated using existing trend curve modeling.
- **Upgrade:** To collect the required data for estimating embrittlement, Charpy impact specimens in the reactor pressure vessel surveillance capsules are harvested and tested to collect information on embrittlement. Historically, a limited number of high fluence data points could be used as input to feed existing standard models of embrittlement trend curves. Subsequent research has demonstrated that this trend curve has limitations in terms of its predictive accuracy at high fluence levels.

The research initiative has improved the accuracy of the modeling of reactor pressure vessel embrittlement trend curves through the use of better physical-based testing using a technique known as mini-compact tension (mini-CT) testing for direct fracture toughness measurement. Additionally, machine-learning models are developed to build better models from these datasets. Better embrittlement trend curves will be used to update the ASTM standard and ASME Code.

- **Advantages / Benefits:** Improvements in surveillance capabilities and better predictive modeling of the rate of embrittlement of reactor pressure vessels allow operators to understand the real condition of plant reactor pressure vessel embrittlement more accurately.
- **Potential Cost Savings:** Because research has demonstrated that existing trend curves underestimated embrittlement to reactor pressure vessel under high fluence conditions, the new research is more conservative and therefore will demonstrate embrittlement sooner than the existing curve. This will enable earlier reactor pressure vessel intervention to extend its life.
- **Challenges:** A challenge the initiative faces is the lack of available specimens with which to derive meaningful conclusions about the reactor vessel’s rate of embrittlement. The reactor vessel surveillance program was initially designed for reactors to operate for 40 years, not the current period of 60-80 years. Therefore, there are fewer overall specimens available in the reactor core to test during its extended life.

To effectively monitor the impact of fluence over extended operating conditions, the same reactor pressure vessel materials are tested throughout the reactor life cycle. However, testing Charpy specimens is destructive and often leads to these specimens being broken in half, and these cannot easily be returned to the reactor pressure vessel. The industry has found ways to overcome this limitation by either reconstructing the Charpy specimen or reinserting that same specimen back into the reactor.

Table 20. Results summary for Charpy Impact Testing Embrittlement Curve (forthcoming).

Technology Requirements	Cost Savings Type	Functions Impacted	Positions Impacted
Charpy Impact Testing Embrittlement Curve (forthcoming)	Multiple	N/A	N/A

## 1.5.2 Thermal Annealing of Reactor Pressure Vessel

Implementation Timing: Project implementable in more than 5 years or Generation 2. See Table 21.

- Opportunity: For reactor pressure vessels that experience high embrittlement from high fluence such that they will require a reactor to be retired prematurely, thermal annealing can be carried out to reduce the defects, recover original properties and extend the lifespan of the reactor pressure vessel and the plant itself. In principle, applying thermal annealing to degraded reactor pressure could extend the life of the plant from between 20-40 years.
- Upgrade: Thermal annealing is the standard process applied for intrinsic stress liberation and structural improvement in materials. Thermal annealing can mitigate radiation damage and partially restore the material. In the case of thermal annealing carried out for degraded reactor pressure vessels, the focus is the beltline of the vessel.

Several different heating methods, including both direct and indirect heating, can be used to heat the vessel with proper insulation applied around the vessel. The reactor pressure vessel is heated to approximately 450°C.

The beltline is most susceptible to irradiation damage because of its position in the center of the reactor pressure vessel where it is exposed to the greatest degree of fluence/flux. An additional reason for its susceptibility is that the beltline might be welded using a material containing a high proportion of nickel and copper which forms additional precipitates. Radiation damage in the vessel is seen through dislocation damage in the beltline which annealing annihilates and leads to restoration of a significant amount of the material's original properties.

- Advantages / Benefits: Thermal annealing allows for restoration of the reactor pressure vessel and usable extension of the component and of the plant itself.
- Potential Cost Savings: The cost to perform reactor vessel thermal annealing is on the order of a nuclear power plant steam generator replacement. To make this procedure economical, thermal annealing would have to be shown to extend plant life for 20–40 years.
- Challenges: There is limited experience in the United States in carrying out thermal annealing on reactor pressure vessels. For instance, a thermal annealing demonstration project was carried in the 1990s to the reactor pressure vessel of the Marble Hill Nuclear Power Station, which was an unfinished nuclear power plant in Indiana. The cost to carry out thermal annealing on a reactor pressure vessel is equivalent to replacing the plant's steam generators.

Some time ago, there were concerns about the embrittlement of the reactor pressure vessel in the Palisades nuclear plant to the extent that thermal annealing equipment was ordered from Russia where it was necessary due to the high fluence of their water-water energy reactor (VVER) reactors. After investigations, however, it was determined that the reactor pressure vessel embrittlement in the Palisades plant was still within NRC regulatory guidance requirement.

As of yet, there has been no potential use-case for the thermal annealing process because of the age of the U.S. nuclear fleet. However, as nuclear plants approach 80 years of age thermal annealing is likely to be necessary to obtain license renewal from NRC.

Table 21. Results summary for Reactor Pressure Vessel Thermal Annealing.

Technology Requirements	Cost Savings Type	Functions Impacted	Positions Impacted
Reactor Pressure Vessel Thermal Annealing	Revenue Generation – Plant Life Extension	N/A	N/A

### 1.5.3 Address Potential Concern of Stress Corrosion Cracking on a High Chromium and Nickel Based Alloy 690

Implementation Timing: Project implementable in 5 or more years or Generation 2. See Table 22.

- **Opportunity:** Another important initiative is to improve the industry’s understanding of stress corrosion and cracking (SCC) on the high chromium nickel-based Alloy 690, which has been applied in nuclear plants to replace Alloy 600. This alloy is used in steam generator heat exchange tubes. The research is important because it will build accurate parameters of the properties of Alloy 690 in different operating conditions over long periods of time.
- **Upgrade:** Alloy 690 was used as a replacement for Alloy 600 due to its lower rate of degradation under normal operating conditions. This initiative was necessary to understand the performance and effective lifespan of Alloy 690. Alloy 690 has replaced alloy 600 as the steam generator material in almost all U.S. nuclear plants. The total duration of this research initiative is 10 years and three years are remaining before it is concluded.
- **Advantages / Benefits:** Improved understanding of the performance of the alloy allows for an enhanced material management program. It will enable revisions to the Alloy 690 inspection program and a potential reduction in the frequency of detailed inspections, which are currently based on the performance characteristics of Alloy 600. The time between each inspection could hypothetically be increased from 18–24 months to 36–48 months or more depending on the research findings.
- **Potential Cost Savings:** Lengthening the time between maintenance activities has the potential to considerably reduce preventative maintenance costs associated with steam generators.
- **Challenges:** No major challenges have been encountered in this initiative.

Table 22. Results summary for Alloy 690 Test Results.

Technology Requirements	Cost Savings Type	Functions Impacted	Positions Impacted
Alloy 690 Test Results	Direct Labor	Contract / Vendor Radiation Protection	Steam Generator Testing

### 1.5.4 Replacing Lithium Hydroxide with Potassium Hydroxide for PWR Water pH Control

Implementation Timing: Project implementable in 3–5 years or Generation 1. See Table 23.

- **Opportunity:** Recently completed research has demonstrated that potassium hydroxide can replace lithium hydroxide as a pH control for primary water in PWRs, with limited impacts on the SCC behavior of relevant material. The costs of procuring lithium hydroxide have been increasing since 2015. Prices have been particularly impacted by the COVID-19 pandemic, the conflict in Ukraine, and the resulting sanctions on Russia, a major producer. In some cases, lithium hydroxide has simply been unavailable and the future dependability of supply chains is unclear. Potassium hydroxide is an available and cost-competitive alternative.
- **Upgrade:** Lithium hydroxide is used to control pH in PWR’s primary water systems to reduce corrosion, increase iron solubility across the core, stabilize fuel crud, and positively impact primary water SCC initiation. Research has demonstrated that potassium hydroxide can be substituted for lithium hydroxide. The substitution does not change crack initiation timing or impact crack growth rate.

- **Advantages / Benefits:** In 2015 numerous utilities were either challenged or completely unable to procure lithium hydroxide. Since then, prices have increased year-on-year making potassium hydroxide a more viable alternative. The fact that the two major sources of supply of lithium hydroxide are Russia and China increases supply chain risks, especially in the context of the conflict in Ukraine and growing tensions in the South China Sea.

Demand for primary water pH control is likely to grow considerably as a result of the growth in flexible power operations and the PWR fleet. Future construction of molten salt reactors (MSRs) will greatly increase the demand for lithium hydroxide, as a single MSR requires as much lithium hydroxide as 760 typical PWR plants. Additionally, research indicates that potassium hydroxide leads to lower general corrosion rates and may mitigate radiation-induced SCC.

- **Potential Cost Savings:** Future cost savings depend on the price trajectory of both lithium and potassium hydroxide. Previous studies demonstrated considerable cost savings for a PWR plant when using potassium hydroxide instead of lithium hydroxide. In 2016, the average price of lithium hydroxide per kg was \$2,500, and for potassium hydroxide it was approximately \$25/kg. At these prices, the cost of a saturated lithium hydroxide CVCS bed would be \$6000 per ft<sup>3</sup> compared to \$300 per ft<sup>3</sup> potassium hydroxide. The estimated total savings per year with these relative prices would be approximately \$140k annually per PWR unit.
- **Challenges:** No major challenges have been encountered in this initiative.

Table 23. Results summary for Potassium Hydroxide vs Lithium Hydroxide.

Technology Requirements	Cost Savings Type	Functions Impacted	Positions Impacted
Potassium Hydroxide vs Lithium Hydroxide	Materials	N/A	N/A

### 1.5.5 Concrete Performance / Degradation After Irradiation

Implementation Timing: Project implementable in more than 5 years or Generation 2. See Table 24.

- **Opportunity:** Another opportunity area is the development of methodological guidelines for assessing the condition and performance of irradiated concrete. The primary concern of the initiative is with the concrete close to the reactor pressure vessel known as the concrete biological shield (CBS), which is used as a shielding and supporting material for the reactor vessel.

This opportunity area exists in the context of plant-by-plant variation in sourcing for concrete and the lack of a universal approach and understanding of the problem of concrete irradiation. The research on the impact of irradiation on concrete carried out so far has been on concrete from test reactors, which have a higher flux than the in-service irradiation condition. A limited amount of research has been carried out using in-service concrete material. This means there is considerable uncertainty about the relevance of existing studies on the majority of conditions to which concrete is exposed. Improved research will require more material harvested from concrete biological shields and other in-service concrete material.

- **Upgrade:** The initiative will use new approaches to develop sophisticated methodological guidelines to be used by industry for experimental and predictive assessments of irradiated concrete. The research hopes to achieve this by developing a physics-based model for accurate prediction of the irradiated properties of concrete. Additionally, the project aims to develop new algorithms to analyze ultrasound data to detect defects in the concrete and create a machine-learning model to detect expansion of the concrete.

- **Advantages / Benefits:** Developing a more sophisticated methodology for measuring and estimating the performance and characteristics of concrete will facilitate a more precise understanding of the long-term performance of the CBS under accidental conditions. For individual plant operators, it will provide specific guidance as to whether their concrete is more susceptible to radiation damage and what the useful life/damage in their concrete material is expected to be.
- **Potential Cost Savings:** As with other initiatives that allow for superior assessment or measurement of material degradation, this project may prevent future unnecessary replacement of existing concrete. Additionally, being able to assess the relative performance of different concrete compositions has the potential to lead to better selection of concrete for future nuclear plant construction.
- **Challenges:** To develop an accurate model for predicting concrete performance after irradiation, harvesting, and testing in-service irradiated concrete is critical. There are limited opportunities for harvesting concrete which by itself also requires a lot of resources.

Table 24. Results summary for Guidelines for Irradiated Concrete.

Technology Requirements	Cost Savings Type	Functions Impacted	Positions Impacted
Guidelines for Irradiated Concrete	Materials	N/A	N/A

### 1.5.6 Developing an Effective Cable Condition Monitoring Program

Implementation Timing: Project implementable in more than 5 years or Generation 2. See Table 25.

- **Opportunity:** An important area of opportunity in which large future benefits may be found is in cable aging, specifically through improvements in condition monitoring. Currently, environmental qualification of cables uses time-based method, and the cables can be used up to the end of the qualification period regardless of the actual cable condition. It is known that there is considerable variation in cable degradation, specifically in the polymers in the elastomers, depending on environmental conditions such as heat, water ingress, and radiation exposure.

By using condition monitoring, the degradation of cables can be accurately assessed, and appropriate decisions taken as to whether the cable needs to be replaced. Ultimately, effective condition monitoring for cables has the potential to lead to a condition-based qualification program replacing the existing time-based program.

The initiative aims to improve condition monitoring by improving the understanding of the limitations of accelerated aging and interpreting cable condition monitoring signals. It also aims to increase the effectiveness of non-destructive cable health measurement and develop advanced technologies for online cable condition monitoring.

- **Upgrade:** Condition monitoring first requires the development of a model that estimates the impact of relevant environmental factors on the speed of degradation of the material or component. These models increasingly integrate machine learning techniques to improve their accuracy over dynamic conditions. Once the model has been built and sufficiently tested for accuracy, real input is used from plant sensors which can be integrated with data visualization capabilities to provide an accurate indication of the real condition of cables in different areas of the plant. The specific cables targeted by this initiative are primarily LOCA and EQ cables.

- **Advantages / Benefits:** The potential benefits of an effective cable condition monitoring program are extensive. The ability to accurately estimate the condition of different cables across the plant will in many cases lead to considerable extensions in their life beyond 60 years, meaning that challenging and costly cable replacements can be delayed. In some cases, condition monitoring is likely to identify those cables where degradation has reduced their lifespan to less than the 60 years. Being able to accurately identify these cables will allow for their replacement before a potentially costly failure occurs.
- **Potential Cost Savings:** The potential cost savings from an effective condition monitoring program are considerable because of the difficulty of replacing cable and the high associated costs. However, no study has yet formally modeled the economics of establishing a cable condition monitoring program and the savings gained within a nuclear plant.
- **Challenges:** As with other condition monitoring and condition-based maintenance programs, the major challenges are associated with integrating the monitoring models into existing operations and with plant operators. Personnel who are responsible for making decisions on cable maintenance and replacement will have to become comfortable with interpreting and acting upon the information provided by the dashboard or the particular data visualization infrastructure used in the plant.

An additional potential challenge with cable condition monitoring is that additional sensors will need to be installed to provide data input sufficient to populate the monitoring program to provide accurate information as to the condition of cables. The number of additional sensors installed will have a potentially large impact on the rate of return of any condition monitoring program.

Table 25. Results summary for Condition-Based Cable Monitoring Program.

Technology Requirements	Cost Savings Type	Functions Impacted	Positions Impacted
Condition-Based Cable Monitoring Program	Cable Replacement Materials and Labor	Multiple	Multiple

## 1.6 Summary Table

Table 26 is a summary of all the research initiatives captured in this document and their expected time of industry implementation.

Table 26. Integrated summary results for all the research initiatives.

Research Areas	Research Title	Implementation Timing
<b>Plant Modernization</b>		
	Modernization of Field-End Digital Infrastructure (1.1.1)	Generation 1 (3–5 years)
	Data Capture and Visualization (1.1.2)	Generation 1 (3–5 years)
	Integrating Artificial Intelligence and Machine Learning with Sensor Deployment (1.1.3)	Generation 1 (3–5 years)
	Use of Enterprise Data for Operational Decision-Making (1.1.4)	Generation 1 (3–5 years)
	Developing a Business Case Concerning the Economic Benefits of Reducing Maintenance Frequencies (1.1.5)	Generation 1 (3–5 years)
<b>Flexible Plant Operations &amp; Generation</b>		
	Use of Nuclear Plants to Produce Hydrogen (1.2.1)	Generation 1 (3–5 years)
	Expansion of Steam Production and Accessing the Markets for Thermal Energy (1.2.2)	Generation 2 (5 or more years)

Research Areas	Research Title	Implementation Timing
	Using Gasification to Turn Black Liquor into Fuel (1.2.3)	Generation 2 (5 or more years)
Risk Informed Systems Analysis		
	Risk-Informed Asset Management (1.3.1)	Generation 1 (3–5 years)
	Risk-Aligned Data-Driven Compliance (1.3.2)	Generation 1 (3–5 years)
	Evaluations of Accident-Tolerant Fuel (ATF) with Higher Burnup (1.3.3)	Generation 1 (3–5 years)
	Plant Reload Optimization (1.3.4)	Generation 1 (3–5 years)
	Risk Assessment of Digital I&C Systems (1.3.5)	Generation 1 (3–5 years)
	Enhanced Fire PRA (1.3.6)	Generation 1 (3–5 years)
	AI Supported LiDAR (1.3.7)	Generation 1 (3–5 years)
	Risk-Informed Aging Management and Subsequent License Renewal (SLR) (1.3.8)	Generation 1 (3–5 years)
Physical Security		
	Augmented Reality for Force-on-Force Exercises (1.4.1)	Generation 1 (3–5 years)
	Advanced Sensors Unique to Nuclear Power Plants (1.4.2)	Generation 1 (3–5 years)
	Performance Based Probabilistic Risk Assessment for Security (1.4.3)	Generation 1 (3–5 years)
	Remote Operated Weapons (1.4.4)	Generation 1 (3–5 years)
Materials Research		
	Predicting the Embrittlement Trend Curve for Reactor Pressure Vessels Under High Fluence Conditions in Extended Operations (1.5.1)	Generation 2 (5 or more years)
	Thermal Annealing of Reactor Pressure Vessel (1.5.2)	Generation 2 (5 or more years)
	Address potential concern of stress corrosion cracking on a high chromium and nickel-based alloy 690 (1.5.3)	Generation 2 (5 or more years)
	Replacing Lithium Hydroxide with Potassium Hydroxide for Water pH Control (1.5.4)	Generation 1 (3–5 years)
	Concrete Performance / Degradation After Irradiation (1.5.5)	Generation 2 (5 or more years)
	Developing an Effective Cable Condition Monitoring Program (1.5.6)	Generation 2 (5 or more years)

### 1.6.1 Observations

It is the purpose and mission of the integrated operations for nuclear (ION) business model and research effort at LWRS to identify and integrate technological and programmatic changes and modernizations to nuclear plant operations. These changes, called work reduction opportunities (WROs), are advanced and integrated into the ION model then verified and explored further in applied ways with partnering utilities and plant sites. As the ION model gains structure, researchers look to add new WROs as components to the existing WRO suite from ongoing research within the LWRS group.

While much of the research presented in this document will have an impact on the domestic nuclear industry, there are standout efforts researchers feel will have a positive effect on nuclear power plant

O&M costs and that utilize technological changes that represent the best of integrated operations for nuclear value. Industry expects new ideas and projects to consider for their ION transformations, therefore the following LWRs research projects are highlighted to be considered for inclusion in the suite of ION work reduction opportunities.

1. Modernization of Field-End Digital Infrastructure (1.1.1).
2. Data Capture and Visualization (1.1.2).
3. Integrating Artificial Intelligence and Machine Learning with Sensor Deployment (1.1.3).
4. Use of Enterprise Data for Operational Decision-Making (1.1.4).
5. Risk-Informed Asset Management (1.3.1).
6. Augmented Reality for Force-On-Force Exercises (1.4.1).
7. Advanced Sensors Unique to Nuclear Power Plants (1.4.2).
8. Performance-Based Probabilistic Risk Assessment for Security (1.4.3).
9. Remote Operated Weapons (1.4.4).
10. Replacing Lithium Hydroxide with Potassium Hydroxide for Water pH Control (1.5.4).

## **1.6.2 Areas for Growth**

ION is focused on plant operations and the implementation of technology and process change to drive sustainable business models. With this objective in mind, some areas of plant operation deserve attention from the research community. The following list will highlight some of these areas and possible research pathways.

- Project management and project estimating – Research into the process of estimating plant modifications and process upgrades at nuclear plants may be productive. Often, projects and engineering upgrades are underestimated when seeking approval and funding. Research into the causes, ramifications, and mitigation strategies may be helpful to the industry. Project management is also ripe for new processes.
- Knowledge retention – There is a multitude of non-proceduralized practices, skills, and even customs at a nuclear plant that are essential to the efficiency of that plant and the overall health of outages, work groups, and other aspects of work (i.e., material staging and laydown area organization). Research into the transmittal of these practices, skills, and customs to the incoming cohort may bear fruit in easing the transition from experienced workers to those who are new to the discipline.
- Configuration management – Configuration management at plant sites is an essential practice and discipline. Without accurate design bases, engineers risk design errors, maintenance planners risk work package errors, and operators risk clearance errors. However, due to the thousands of drawings, it can be difficult and time-consuming to update them all. Many have been abandoned or semi-abandoned creating an element of risk of mismatch. Research may be able to quantify this risk and come up with time-saving solutions not only to the current population of un-updated drawings, but to the entire configuration management process of mark-ups, drawing revision, review, approval, and document processing.



# Appendix A

## Research Area Summary Materials Plant Modernization Group



### Plant Modernization Pathway Overview

Craig Primer  
8/1/2023



### Research Objectives and Goals



Significantly reduce risk of modernization by:

- Developing technology modernization solutions that address aging and obsolescence challenges
- Delivering a sustainable business model that ensures continued safe, reliable operation at a cost competitive level

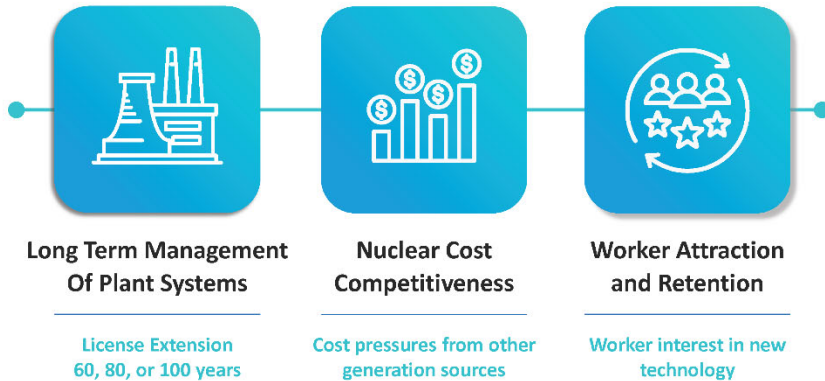



## Research Area Overview



### Key Areas of R&D

#### Research Area Goal:

Extend life and improve performance of existing fleet through modernized technologies and improved processes for plant operation and power generation

#### Human & Technology Integration

Provides effective integration of plant personnel and innovative technologies maximizing efficiency and ensuring no impact to safe and reliable plant operation

#### Digital Infrastructure

Develop a sustainable plant hardware architecture design that enables transition of legacy analog equipment to new advanced digital design, effectively addressing human factors, cost, and regulatory considerations

#### Integrated Operation for Nuclear

Achieve LWR fleet electric market competitiveness by transforming the nuclear business model through business-driven technology and innovation, to achieve long-term technical and economic viability.

### Plant Modernization

#### Data Architecture & Analytics

Develop advanced data collection, monitoring, and processing technologies, displacing a substantial number of labor-intensive plant support tasks using process automation

3

## PM Pathway Stages of Transformation

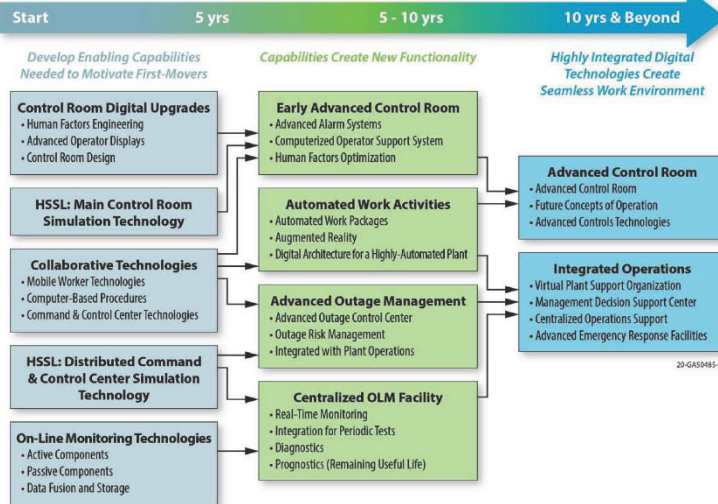

#### Stages of transformation :

Extend life and improve performance of existing fleet through modernized technologies and improved processes for plant operation and power generation

4



## FY24 Proposed Research

Pathway Priority	Work Package #	Work Package Title	FY23 (\$K)	Cum. FY23 (\$K)
1	LW-24IN060101	Project Management at INL (Plant Modernization)	\$474	\$474
2	LW-24IN060310	Advance Concepts of Operations	\$1,570 *	\$2,044
3	LW-24IN060309	Instrumentation and Control Infrastructure Modernization / Digital Infrastructure	\$860	\$2,904
4	LW-24IN060304	Digital Architecture for an Automated Plant	\$1,425 *	\$4,329
5	LW-24IN060308	Technology Enabled Risk-informed Maintenance Strategy	\$850	\$5,179
6	LW-24IN060311	Efficient Plant Operations Concept using Human-system-integration	\$550	\$5,729
7	LW-24IN060307	Advanced Remote Monitoring for Operations Readiness	\$200	\$5,929
8	LW-24IN060302	Industrial and Regulatory Engagement	\$75	\$6,004
Over Target				\$6,004
	Work Package #	Work Package Title		
9	New	Accelerated Deployment of Automation Methods - ADAM	\$1,000	\$7,000



## Integrated Operations for Nuclear

### Performance Milestone Scope:

Complete an industry pilot demonstrating the implementation of the Integrated Operations for Nuclear (ION) business model change process.

### Outcomes:

- Demonstrate the ION Business Model Change Process
  - Complete the identification of top cost drivers within the nuclear business model
  - Demonstrate developing a utility-specific change plan to achieve cost competitiveness.
  - Demonstrate with industry, the ION business model technology integration process to identify and evaluate the appropriate change needed to achieve cost competitiveness.
  - Create a utility-specific business model transformation plan

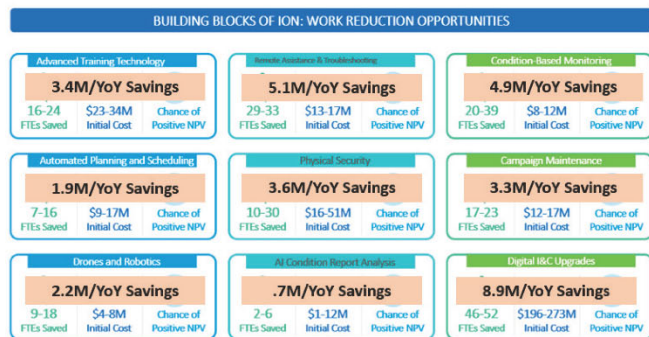

Xcel Energy Implemented ION and sees dramatic cost reductions

\$60 Million Dollar estimated harvestable annual cost savings by implementing ION



## Human & Technology Integration Digital Infrastructure

- **Providing Practical Guidance to the Industry on How to Implement Digital Upgrades**
  - Developed practical industry guidance explaining how to apply human-technology and human factors engineering to digital function analysis and allocation planning (INL/RPT-22-68472 “Demonstration and Evaluation of the Human-Technology Integration Function Allocation Methodology”)



## TERMS (Technology Enabled Risk-Informed Maintenance Strategy)

### Performance Milestone Scope:

Complete the demonstration of trustworthiness and explainability for validation and verification of risk-informed predictive maintenance machine learning and artificial intelligence technologies

### Outcomes:

- Provided verification of trustworthiness and explainability for machine learning (ML) and artificial intelligence (AI) technologies necessary to enable implementation of predictive maintenance strategy.
  - In collaboration with industry partners, a human-in-the-loop evaluation of explainability metrics was performed validating the predictive maintenance strategy developed by LWRS researcher.

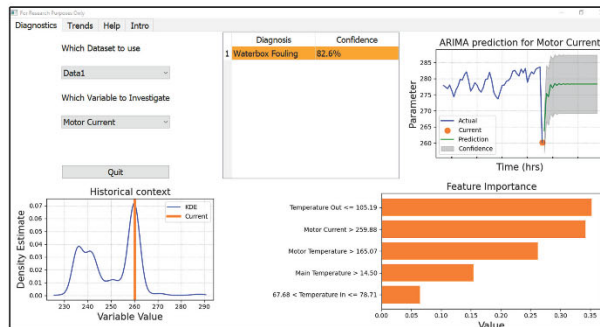

User Interface with Important Parameters Identified, Key Metrics, and Outcome Predicted.

## Created A Digital Platform to Manage Nuclear Power Plant Data and Compliance Activities More Efficiently

- o The LWRS program has designed and developed a national data portal for use by nuclear industry related organizations to facilitate coordination, data sharing, and reviews regarding compliance verification and demonstration.
- o The data portal leverages Machine Intelligence for Review and Analysis of Condition Logs and Entries (MIRACLE), a 2022 R&D 100 award winner, to analyze plant performance using natural language processing and machine learning

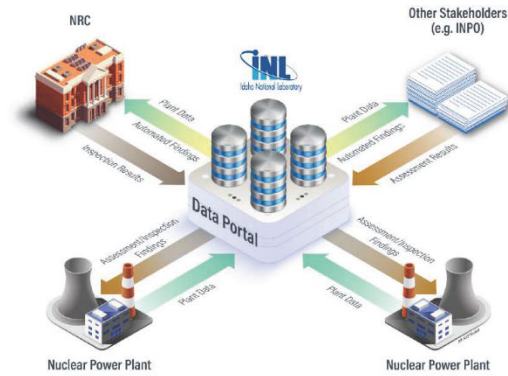

A data portal stores and processes data from nuclear power plants to enable efficient collection and analysis of data to streamline compliance activities

## Advanced Remote Monitoring

- Process Anomaly Detection
  - Preprocessing
  - Grouping
  - Analysis
- Fire Watch
- Transformer Health Monitoring
- Operator Rounds



Role of anomaly detection in prevention of failure escalation



Fire detection in a video stream

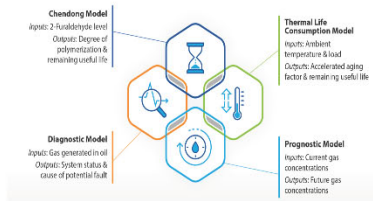

Methods used in DGA for transformers health monitoring

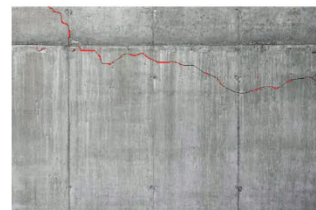

Image anomaly detection



## Questions?

Craig Primer -  
[craig.primer@inl.gov](mailto:craig.primer@inl.gov)  
817.219.4363

# Appendix B

## Flexible Plant Operations & Generation (FPOG)



Richard Boardman  
July 2023

### Flexible Plant Operation & Generation



#### Flexible Reactor Siting

- Data Centers
- Manufacturing Plants
- Biofuel Plants / Processing
- Desalination
- Industrial Parks / Plants
- Fueling Stations



- CO2 / Carbon Sources
- Ethanol Plants
- Direct Air Capture
- Power Generators
- Cement Plants
- Biomass
- Polymer / Chemical Waste

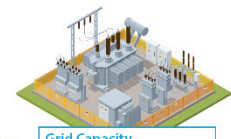
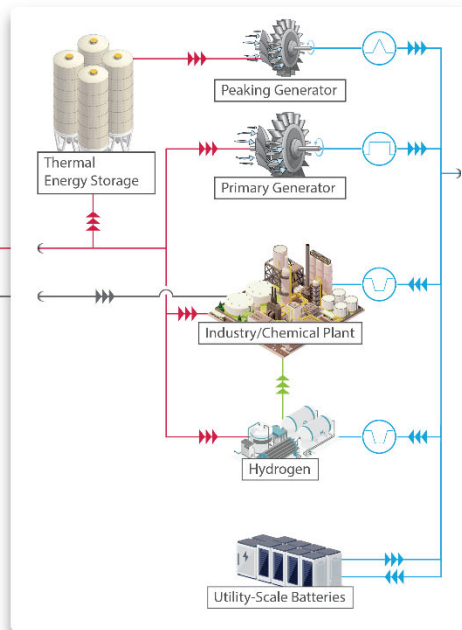

Grid Capacity  
Firm, Flexible, Zero Carbon

- Transportation Fuels
- Steel Production
- Fertilizer / Ammonia
- Polymers / Chemicals
- Hydrogen

- Refineries / Oil Production
- Minerals
- Wood / Paper Plants
- District Heating



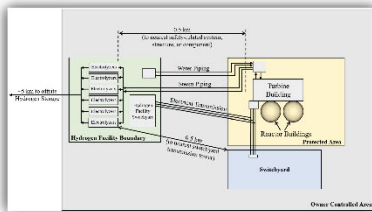

**Technical & Economic Assessments**

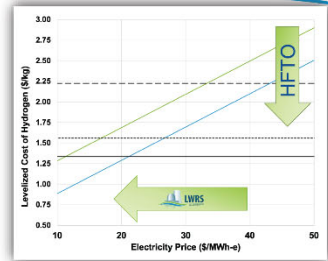

**Second Application Interfaces**

**Regulatory Research & Risk Assessments**

## What's new in 2024?

- \$7 M plus-up in FY23 for hydrogen DOE cross-cutting R&D
- \$500 K for increased management duties

## Overview of Planned Activities

- Regular meetings with NRC
- Complete TEA for Southeast U.S.- specifically the Gulf Shores
- Develop a data base for screening LWR hydrogen production and hydrogen user scenario opportunities and barriers
- Co-Optimize hydrogen plant integration with electrolysis OEM engagement
- Complete safety and preliminary PRA for close coupled H2 production and user plants
- Evaluate true/total value of FPOG in supporting the grid reliability and Earthshot goals
- Design and assessment of large thermal energy extraction systems (controls, transport, storage & heat boosting)
- Apply thermal extraction design basis to BWRs



## Key FY23 Accomplishments

- Methanol Synfuels Production technical and Economic Assessment
- TEA In-Progress:
  - Energy Arbitrage Study,
  - Simplified Calculator for Hydrogen versus Electricity Market Strategies
- Control Concepts Tested for thermal dispatch with GPWR at Human Systems Simulation Lab
- Thermal and Electrical A/E Preconceptual Designs
  - 100 MWe HTE Hydrogen Plant
  - 500 MWe HTE Hydrogen Plant
  - 30% Thermal Energy extraction
- Updated PRA
  - Sandia hydrogen explosion impacts
  - Updated pre-PRA for 500 MWe Plant with conceptual commercial HTE layouts
  - Coming soon: Updated pre-PRA with commercial layouts for 1,000 MWe H2 plant

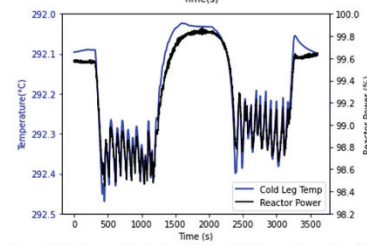
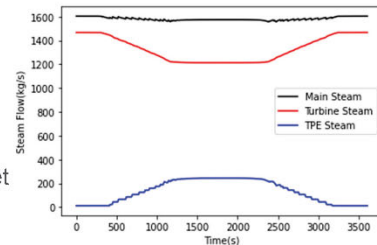

Jancovec, S.; Weckover, J. Simulation of 10% and 50% Thermal Power Dispatch to an Industrial Facility Using a Flexible Generic Full Scope Pressurized Water Reactor Plant Simulator. *Energies* **2022**, *15*, 1151. <https://doi.org/10.3390/en15031151>



## Progressive R&D Support of Nuclear Integrated Hydrogen (HTE)

2020

- FPOG/Industry Stakeholder Meetings
- Hybrid Operations Studies
- Prelim H2 Risk Analysis
- Licensed Operator Validated HSSL Simulations

2021

- TEA (Financial Modeling)
- Integrating H2 Designs in PRA
- Advanced PWR/HTE HSSL Simulations
- DOE Supported H2 Pilot Plant Support
- ANS UWC Outreach

2022

- H3RG (Industry/Lab/AE) Formation
- H2 "101" Presentations
- R0 M3 Report (100 MW<sub>nom</sub> HTE)
  - Elect, Mech, & Controls Design
  - 10 CFR 50.59 Basis
- iFOA 1817 Support

2023

- R1 M3 Report (500 MW<sub>nom</sub> HTE)
  - Implementing Cost Est
- 30% Ext Steam Case
- Hydrogen Island Concepts
- EPRI Tool Collaboration
- H2 Haz Analyses & FMEA (SNL & INL)

## Probabilistic Risk Assessment

### Preliminary PRA

- Concluded that the addition of a heat extraction system and supplying steam to a high-pressure hydrogen electrolysis facility was safe at 500-meter standoff distance from point of maximum detonation potential to most fragile nuclear SSC (switchyard transmission tower)
  - Used 10 CFR 50.59 criteria and support by NRC RG 1.174
  - INL/EXT-20-60104, Revision 1, Nov. 2022

### Updated PRA

- Updated design information for all systems involved
- Siting analysis for nuclear power plant safety, public safety, and economic advantage.
- Seismic analysis
- Add a CAFTA version of the PRA for industry use
- Scheduled for September 2023

## Key Industrial Engagement

- Entergy SPP for hydrogen production
- Regular H3RG Meetings; CERTREC Support
- EPRI: Nuclear Beyond Electricity and Hydrogen Implementation Guidelines
- **Westinghouse CRADA** – Implementation of Full-Scope Simulator and co-development of human factors for energy dispatch
- Westinghouse iFOA-1817 – Development of thermal and electrical power delivery to hydrogen plants, and control systems
- **S&L A/E thermal energy extraction and electrical connections design and costs to hydrogen plants**
  - Note: Generic Plant design is pre-conceptual vs conceptual if it were for a specific plant
  - Costs are Class 5 for equipment and construction
- **iFOA Hydrogen Demonstrations Projects**; Support from INL, NREL, and ANL
- **Stakeholder Advisory Board Meetings**

## Sargent & Lundy (S&L) Areas of Support 2022 - 2023

- **Pre-Conceptual Integrated Plant Designs**
  - Integrated NPP – 100MW<sub>DC</sub> Hydrogen Facility
  - Integrated NPP – 500MW<sub>DC</sub> Hydrogen Facility
- **Large Scale NPP Thermal Power Extraction (TPD)**
  - 30% TPD (~1100MW<sub>th</sub>)
    - Heat Balance Model Analysis
    - Plant Transient Analysis
    - Effects on Plant Equipment
- **H3RG – Licensing**
  - Draft 10 CFR 50.59 Licensing Reports to support Pre-Conceptual Designs
- **Hazard Analysis Support**
  - Pipe Size and Hydrogen Mass Evaluation
  - Pipe Break Consequence Evaluation
  - Failure Modes and Effects Analysis Review

### Hydrogen Plant Siting Analysis – Nov. 2022 Report

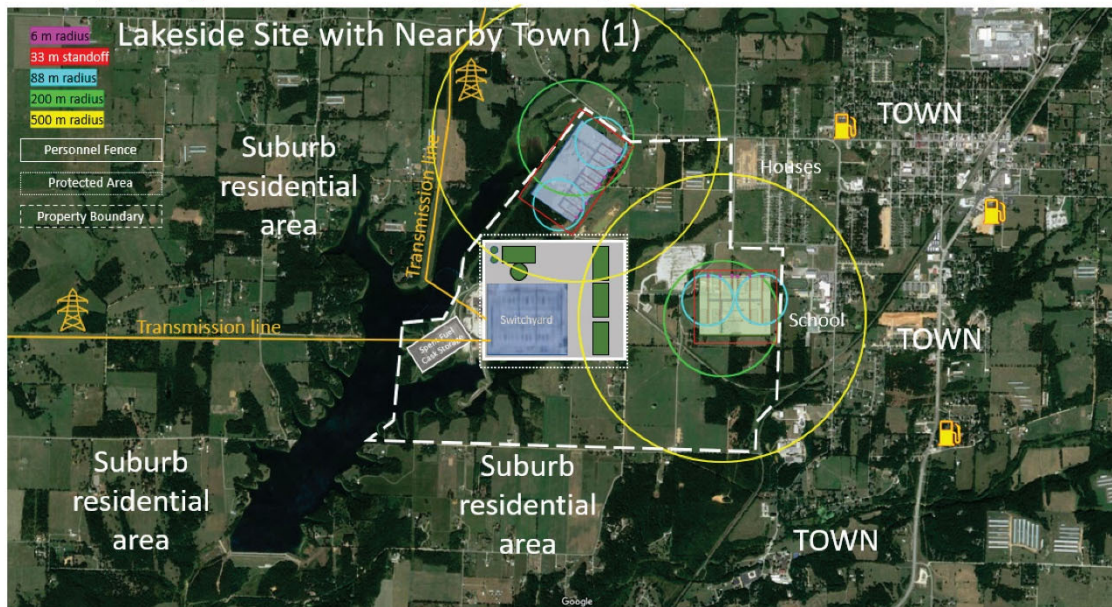

## S&L Pre-Conceptual Plant Designs

- **NPP Reference Plant**

- Based upon typical for 1/3 of operating US NPP Units
  - Westinghouse 4-loop PWR
  - 1200MW<sub>e</sub> / 3,700MW<sub>th</sub> / SWYD: 345kV
  - Hydrogen Steam Supply (HSS) Equipment

- **Hydrogen Facility Plants**

- 100MW<sub>DC</sub>
  - Thermal Load – 20MW<sub>th</sub>
  - Hydrogen Production - 60 tons/
- 500MW<sub>DC</sub>
  - Thermal Load – 100MW<sub>th</sub>
  - Hydrogen Production - 300 tons/day

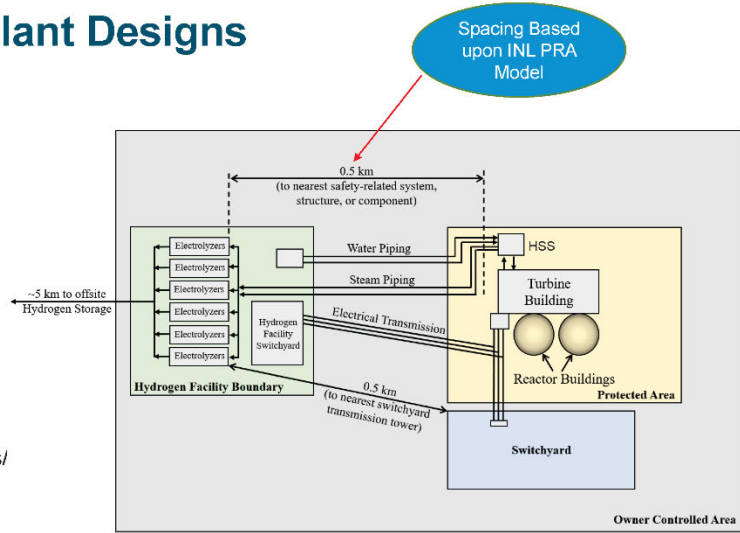

## S&L Pre-Conceptual Plant Designs

- **Conclusions**

- FOAK NPP-H2 Cost Estimating
  - Class 5 Estimate - Purpose is to understand the magnitude of the Project Costs
  - NPP Integration Costs
    - \$60-250/kW<sub>DC</sub>
  - H2 Plant Costs
    - \$350-650/kW<sub>DC</sub>
- Total expected Project Costs
  - Integrated NPP-H2 SOEC Facility
    - \$750-1,250/kW<sub>DC</sub>

H2 Plant Costs from INL Report INL/JOU-22-69185

Reduction in \$/kW as project size increases and distance to NPP is reduced

Table 6-1. Cost Summary for Integration of Nuclear and Hydrogen Plants

Description	100-MW <sub>DC</sub> Design		500-MW <sub>DC</sub> Design	
	500 m Separation	250 m Separation	500 m Separation	250 m Separation
<b>Direct Costs</b>				
Labor	2,075,247	1,457,069	3,596,859	2,558,137
Material	2,365,820	1,426,949	3,898,426	2,580,470
Subcontract	1,335,951	1,060,793	1,795,951	1,520,793
Construction Equip.	484,859	312,550	814,510	551,401
Process Equipment	1,161,540	1,161,540	2,355,000	2,355,000
<b>Total Direct Cost</b>	<b>7,423,417</b>	<b>5,418,931</b>	<b>13,660,796</b>	<b>10,167,461</b>
<b>Indirect Costs</b>				
Additional Labor	572,047	401,623	991,427	705,156
Site Overheads	1,455,759	1,022,074	2,523,010	1,794,501
Other Construction Indirects	2,262,085	1,262,423	5,069,187	3,358,192
Project Indirects	3,959,791	3,856,659	4,375,066	4,158,323
<b>Total Indirect Cost</b>	<b>8,979,682</b>	<b>7,262,761</b>	<b>12,958,680</b>	<b>10,216,174</b>
<b>Contingency Costs</b>				
Contingency on Labor	349,098	225,036	595,447	397,009
Contingency on Material	1,684,354	1,063,659	2,741,136	1,815,361
Contingency on Subcontract	2,910,418	2,043,372	5,044,110	3,587,642
Contingency on Construction Equip.	667,976	530,367	897,976	760,367
Contingency on Process Equip.	609,509	609,509	1,552,247	1,552,247
Contingency on Project Indirects	1,999,595	1,928,328	2,187,533	2,079,163
<b>Total Contingency Cost</b>	<b>8,201,549</b>	<b>6,340,891</b>	<b>13,069,449</b>	<b>10,191,815</b>
<b>Total Cost</b>	<b>24,694,648</b>	<b>19,022,493</b>	<b>39,028,345</b>	<b>30,575,454</b>
<b>Standardized Cost (\$/kW<sub>DC</sub>)</b>	<b>246.0</b>	<b>190.2</b>	<b>78.1</b>	<b>61.2</b>

## S&L Hazard Support Summary

### Hazard Analysis Support

- Pipe Size and Hydrogen Mass Evaluation
- Pipe Break Consequence Evaluation
- Failure Modes and Effects Analysis Review

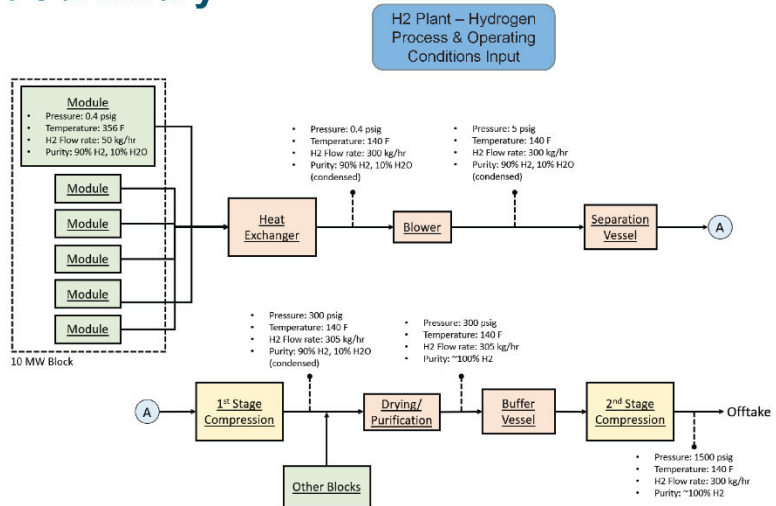

## S&L Licensing Support Summary

### H3RG – Licensing

- Draft 10 CFR 50.59 Licensing Reports
  - Integrated NPP – 100MW<sub>DC</sub> Hydrogen Facility
  - Integrated NPP – 500MW<sub>DC</sub> Hydrogen Facility

Excellent interactions and support from Industry H3RG Participation

### Conclusion

- Results from both Licensing Reports provide favorable pathway for implementing Integrated NPP – Hydrogen Facilities under the 10 CFR 50.59 process

# S&L 30% TPD Design

## Research Objective

- Confirm feasibility of extracting large volumes of thermal energy from a PWR for *non-hydrogen specific* applications
- Thermal Load –  $1,100\text{MW}_{\text{th}}$

## Physical Design Impacts

- Thermal Extraction
  - Main Steam System Extraction Point (~22%)
  - Volume of Thermal Extraction requires Four (4) Trains of HSS

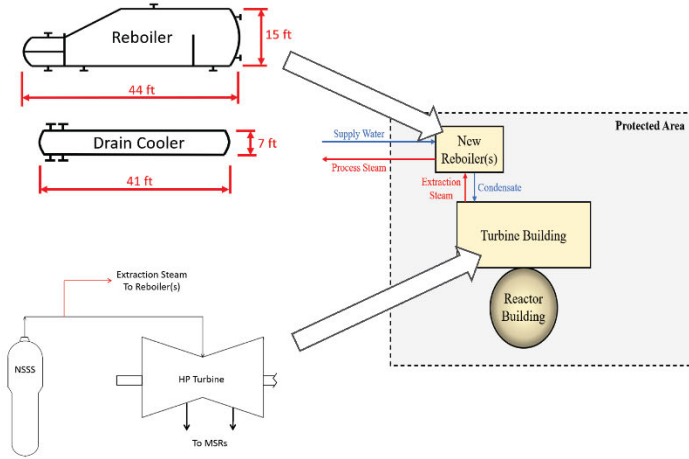

# S&L 30% TPD

## Thermal Analysis

- Extracted Steam is Condensed and subcooled before returning to the Power Cycle

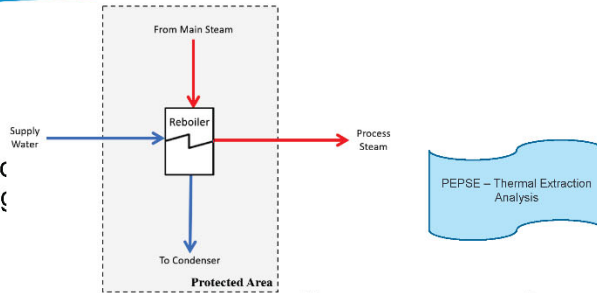

## Transient Analysis

- Multiple Scenarios Reviewed
  - Start-up
  - Shut Down
  - Unit Trip

30% TPD Operation is Well within NPP Control System Capacity

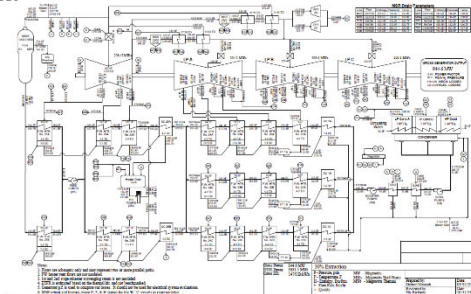



## Sustaining National Nuclear Assets

*[lwrs.inl.gov](http://lwrs.inl.gov)*

# Appendix C

## Research Area Summary Materials Risk Informed Systems Analysis (RISA)



Svetlana Lawrence  
October 11, 2022

### Risk-Informed Systems Analysis (RISA) Pathway Overview

*2022 RISA Stakeholder Engagement Meeting*





# Light Water Reactor Sustainability (LWRS) Program

## LWRS Goal:

Enhance the safe, efficient, and economical performance of our nation's nuclear fleet and extend the operating lifetimes of this reliable source of electricity

- Plant Modernization** *Enable plant efficiency improvements* through a strategy for long-term modernization
- Flexible Plant Operation & Generation** *Enable diversification* of light-water reactors to produce non-electrical products
- Risk Informed System Analysis** *Develop analysis methods and tools* to optimize safety and economics
- Materials Research** *Understand and predict* long-term behavior of materials
- Physical Security** *Develop technologies* to optimize physical security



# Risk-Informed Systems Analysis (RISA)

- **Objective (the what)**
  - R&D to optimize safety margins and minimize uncertainties to achieve **economic efficiencies** while maintaining high levels of safety
- **Approach (the how)**
  - Provide scientific basis to better represent safety margins and factors that contribute to cost and safety
  - Develop new technologies that reduce operating costs
- **Areas of Expertise**
  - Advanced modeling of physics-based phenomena
    - Thermal-hydraulics, neutronics and reactor physics, risk-informed material degradation, uncertainty propagation
  - Advanced Data Analytics and Digital Modeling
    - Diagnostic and prognostic analyses, resource optimization, AI/ML technologies, digital twins, uncertainty propagation
  - Probabilistic Risk Assessment (PRA) and Human-Reliability Analysis (HRA)



RISA Framework



## Risk-Informed Asset Management

- **Objectives:**
  - Optimization of plant health monitoring and asset management to lower O&M costs
  - Provide information about system performance in clear and effective way
- **Benefits:**
  - Reduced O&M Costs
    - Enhanced system performance
    - Optimized plant resources
  - Reduced Capital Costs
    - Effective reliability / ageing management
  - Support of decision-making processes related to system performance
    - Detailed information available to systems engineers and plant management

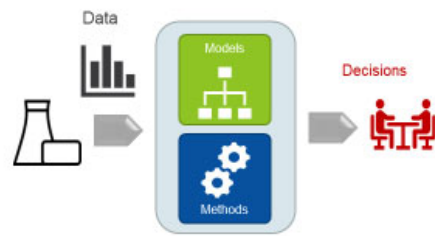

Risk-Informed Asset Management Conceptual Framework



Risk-Informed Asset Management: Integrated Processes

## Risk-Aligned Data-Driven Compliance

- **Objectives:**
  - Automation of Corrective Action Program (CAP)
  - Use data to inform compliance activities
  - Development of equipment performance trends
- **Benefits:**
  - Significantly reduced manual labor
  - Greatly reduced human errors and subjectivity
  - Performance trends
    - Valuable information to support compliance activities and risk-informed decision making

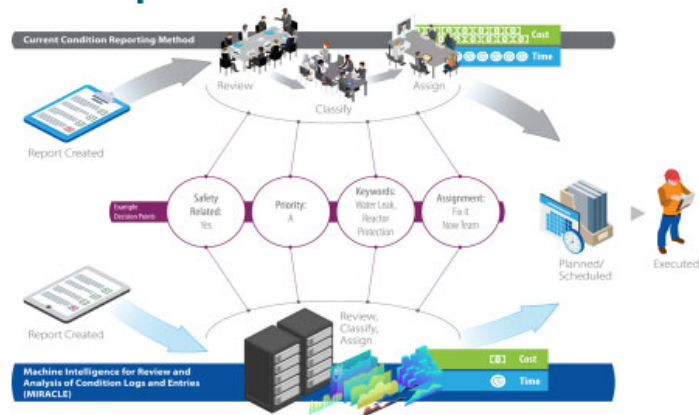

Schematic of Workflow for CAP-Related Assessments



**MIRACLE** (Machine Intelligence for Review and Analysis of Condition Logs and Entries) is an artificial intelligence tool developed to automate condition report handling with natural language processing and machine learning.

## Evaluations of accident-tolerant fuel (ATF) with Higher Burnup

- **Objectives:**
  - Safety assessments of ATFs with increased enrichment and higher burnup (HBU)
    - Specific focus of addressing Fuel Fragmentation, Relocation, and Dispersal (FFRD) issue
  - Support of regulatory approvals of HBU ATFs
    - Risk-Informed approach is seen as the most likely pathway to regulatory approvals
- **Benefits** of HBU ATF Implementation:
  - Economic gains via extended refueling cycle
  - Opportunities for power uprates
  - Reduced fuel costs due to better utilization of fuel in the reactor core
  - Reduced costs for spent fuel processing



Image Credit: U.S. Department of Energy

## Plant Reload Optimization

- **Objectives:**
  - All-inclusive integrated framework for fuel reload analyses
  - Optimization of core configuration to minimize new fuel volume
- **Benefits:**
  - 5-10% reduction in new fuel cost
  - Innovative core load analysis framework
    - Traditional methods (developed decades ago) are labor-intensive and time-consuming
  - Framework supports ATFs, high burnup and longer cycle
    - Since already transitioning to ATFs, why not implement more efficient reload analysis tools at the same time?

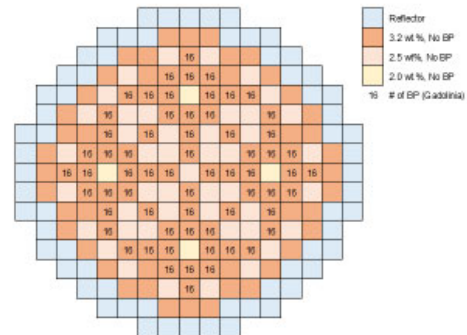

Example Configuration of Reactor Core

## Risk Assessment of Digital I&C Systems

- **Objectives:**

- Develop an integrated platform for risk assessments of Digital I&C Systems
- Support Risk-Informed approaches

- **Benefits:**

- Potential elimination of the requirement for diverse systems to mitigate consequences of CCFs
- An approach to evaluate various system architectures
- Allows to find a “Good Enough” system design
- Reduce efforts for validation and testing of safety-related DI&C systems

### Potential Expanded DI&C CCF Policy



Left: The NRC staff’s plan to expand the current NRC policy for addressing CCFs  
 Right: Risk-informed capabilities developed in RISA framework for risk assessment of digital systems.

## Enhanced Fire PRA

- **Fire Risk in 3D (FRI3D) Tool**

- NOT a methodology change
  - no need in PRA peer review
- Coupled with industry-accepted fire modeling codes & calculations
  - CFAST, FDS, Heat Soak, THIEF
- Incorporated 3D visualization into existing fire models
- Enhances existing critical scenarios
  - no need to re-create everything from scratch

- **Benefits**

- Visualization of fire scenarios improves information sharing
- Multiple “what-if” scenarios evaluated in minutes
- Fast evaluations of plant modifications
- Timely support of SDPs
- Evaluations in-house with minimum training

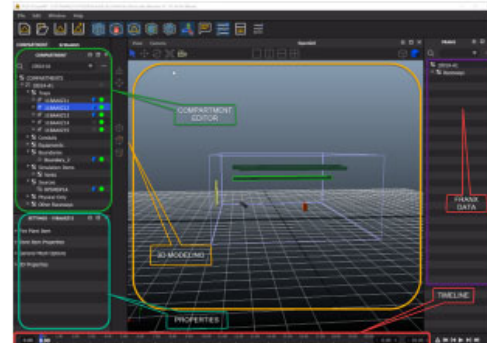

FRI3D User Interface

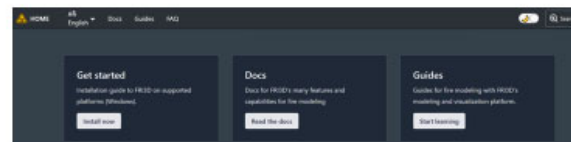

FRI3D Website ([fri3d.centroidlab.com](http://fri3d.centroidlab.com))

## AI-Supported LiDAR Technology

- **Improved use of LiDAR technology**
  - LiDAR is mature enough for Point Cloud to CAD modeling and commercially available.
  - Issues to be solved for risk-informed applications
    - Limited use without integrated information
    - Labor intensive to tag all components.
- **AI-Supported LiDAR**
  - Coupled interface with NPP component databases
  - Intelligent assisted identification.
- **Benefits**
  - Support of plant walk-downs, fire/flood modeling, outage planning, staff training



*LiDAR Model*



*LiDAR-recognized and AI-interpreted equipment tags from equipment database*



## Dynamic Human Reliability Analysis

- **Objectives:**
  - Create a usable and adaptable standalone software tool for dynamic human reliability analysis (HRA)
  - Develop example applications and use cases to meet industry HRA needs
- **Benefits & Accomplishments**
  - Easy-to-use software tool built on plant operating procedures
  - Auto-calculation of performance shaping factors during scenarios
  - Coupling with RELAP5-3D for plant simulation
  - Demonstration of industry-relevant accident scenarios

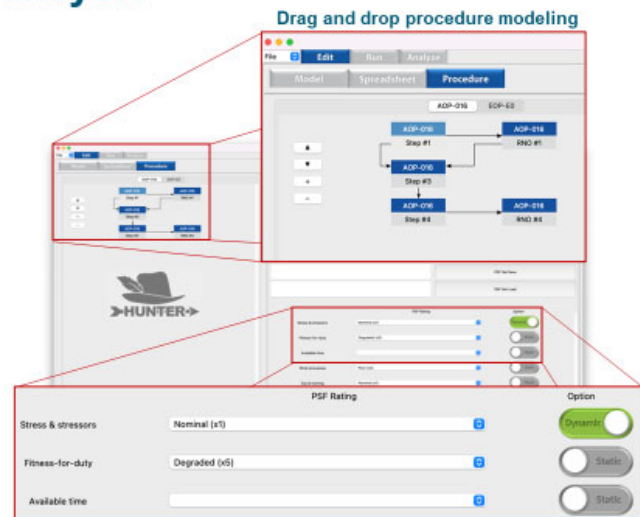

*Dynamic calculation of performance shaping factors*

# Dynamic Risk Assessment\*

\* Not "If" but "When", not "Why?" but "Why Not?"  
US NRC, ML19066A389

## Traditional Risk Assessment

- Heavy reliance on bounding scenarios
- Probabilistic and deterministic analyses are separated
  - Coupled via assumptions, boundary conditions, success criteria
- Risk metrics are surrogates for consequences
  - CDF/LERF instead of radiation dose
- Safety margins  $\Delta$ CDF/ $\Delta$ LERF have limitations in their use

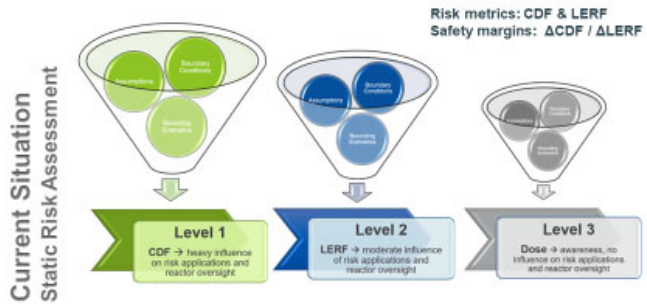

## Dynamic Risk Simulation

- Integration of:
  - Dynamic scenario simulations with human-in-the-loop (probabilistic part)
  - Physics-based analyses (deterministic part)
- Allows to use observable metrics as safety margins to support regulatory compliance
  - Time, crack size, pressure, viscosity, temperature, etc.

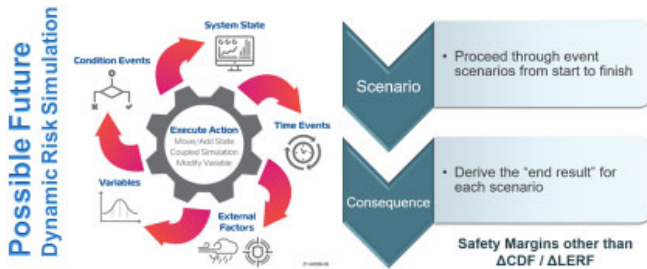

# New Research in FY23



- **Risk-Informed Aging Management and Subsequent License Renewal (SLR)**
  - Support of current industry activities
    - Enhancements in phenomena understanding and long-term prognosis of aging mechanisms
  - Research of long-term strategies
    - Application of risk-informed, performance-based approaches instead of deterministic-only processes currently employed
- **Support of urgent industry interest in power uprates**
  - Recent federal legislatures (i.e., Infrastructure Law, Inflation Reduction Act) offer significant opportunities for increased revenue for nuclear power plants
    - Nuclear power plants can capitalize via direct credits or tax credits
  - A feasibility study will be conducted to develop business cases
    - Market assessment, required investment analysis, associated limitations, various revenue sources (e.g., electricity, hydrogen, electricity + hydrogen)
- **Optimization of plant outages**
  - Most outages take a few days longer than "critical path" due to unforeseen complications and emergent issues
    - Identify the most common issues based on historical performance using AI/ML technologies
    - Use RISA-developed tools to predict potential issues either in planning stage or during outage

# Appendix D

## Physical Security



Douglas M. Osborn, PhD  
Pathway Lead

July 2023

## Physical Security Research



Sandia National Laboratories is a multi-mission laboratory managed and operated by National Technology & Engineering Solutions of Sandia, LLC, a wholly owned subsidiary of Honeywell International Inc., for the U.S. Department of Energy's National Nuclear Security Administration under contract DE-NA0001620. SAND2023-0946M, SAND2023-22407C, & SAND2023-42207C



### Motivation for LWRS Physical Security R&D

- Why is LWRS focusing on Physical Security?
  - Industry approached LWRS seeking help with physical security at a stakeholder engagement meeting
  - Expressed interest in technologies provided by DOE to other government agencies and how they could be leveraged
  - Physical security accounts for approximately 20% of staffing at nuclear power plants
  - Many efficiencies are possible to reduce this percentage while maintaining security system effectiveness
  - Utilities often lack the technical basis to effectively implement these efficiencies
- Physical security is crucial to maintain a safe and reliable nuclear energy fleet
  - Physical security programs at US nuclear sites started to increase in the 1980s to meet changes in the design basis threat (DBT)
  - September 11, 2001 led to even more changes to the DBT and significant increases in physical security at nuclear power plant sites
  - Modernization of infrastructure and control systems for US nuclear power plants provides an opportunity to apply advanced tools, methods, and automation to modernize their physical security programs

## Overview of Physical Security Pathway

Physical Security research aims to create tools, technologies, and capabilities for performance-based, risk-informed decision making with the following objectives:

- Develop mitigation strategies and enhance the technical basis necessary for stakeholders to reevaluate physical security postures while meeting regulatory requirements
- Analyze the existing physical security regime, current best practices, and compare/contrast insights with alternative methods which leverage advanced modeling and simulation, modern technologies, and novel techniques that address the design basis threat and regulatory requirements

Short-term goal is to enable industry to operate nearer the staffing requirements of 10 CFR 73.55

Main research focus areas:

- Advanced Security Technologies
- Risk-Informed Physical Security
- Advanced Security Sensors and Delay



Force-on-Force Exercise



Unattended Opening Performance Test

## FY-23 Activities

- Stakeholder Engagement Meetings
  - Vulnerability Assessment Workshop
    - August 22-25, 2023 at INL
    - October 23-27, 2023 at SNL
- Advanced Security Technologies
  - Remote Operated Weapons System (ROWS)
- Risk-Informed Physical Security
  - Dynamic Risk-Informed Framework
  - Performance-based Data Collection Methodology
    - Leveraging DOE's Vulnerability Assessment (VA) method
- Advanced Security Sensors and Delay
  - Deliberate Motion Analytics (DMA)
  - Water Intake Sensors
  - CARBON Wireless (jam-resilient, cyber-hardened)
  - Delay Technologies to Vital Areas



Barrier System Performance Test



Heavy Wall Breach Performance Test



## Recent Accomplishments

- Completed first FY-23 stakeholder engagement meeting in February
- Completed preliminary Sentry-II ROWS modeling with collaborating nuclear utilities
- Completed unattended opening (UAO) performance testing and issued final report
- Conducted preliminary analyses for developing a risk-informed security methodology with pilot nuclear utility and PWROG
- Expanded performance test data collection (security sensors, ballistics, and explosives)
- Access for NRC licensees to 4 DOE Security System Desk References (SSDRs)
- Completed two pilot studies of DMA with collaborating nuclear utilities



Security Modeling of Attack Pathway



Fence Climb Performance Test

## Industry Engagement

ROWS	UAO	DMA	Water Intake Sensors	Dynamic Risk Framework	DOE VA Method	CARBON Wireless	Delay	DOE SBIR	DOE NEUP
Entergy	Entergy	Entergy	TVA	APS	APS	Constellation	APS	ARES	Ohio State
Xcel Energy	Xcel Energy	AEP	Xcel Energy	SNC	RhinoCorps		Constellation	RhinoCorps	
Constellation	Constellation	Constellation	Constellation	PWROG	Constellation				
NRC	NEI	NRC	PSEG	RhinoCorps	ARES				
	Stars Alliance			NRC	NRC				
	Dominion								
	SNC								
	NextEra								
	NRC								

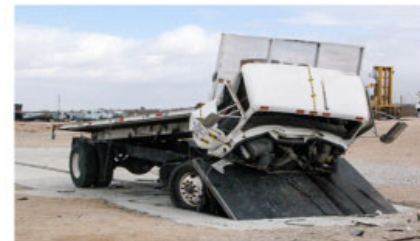

Vehicle Barrier Performance Test

## Impactful Out-Year Outcomes (within 3-years)

- ✓ Provide the technical basis for unattended openings (2D and 3D)
- ✓ Provide access to technical documents from DOE's Office of Security and NNSA
  - Interim Access Delay, Intrusion Detection and Video Assessment, Alarm Communications and Display and Security Communications, and Entry Control and Contraband Detection SSDRs
- Fleet-wide application of risk-informed access delay timelines for adversary and response force
- Support deployment of ROWS to at least one candidate site
- Pilot an integrated approach to dynamic force-on-force and reactor system response modeling
- Pilot the integration of human factors data and modeling for adversary and protective force
- Support deployment of advanced security sensor technologies
  - Sensor fusion
  - Deliberate Motion Analytics
  - Jam-resilient, Cyber-hardened wireless



Security Sensor Performance Test

## Remote Operated Weapons System (ROWS)

**Impact:** Leverage an existing US Government ROWS solution for external and internal deployment at domestic nuclear power plant sites for an added force multiplier. Reductions in response force with increased survivability of overall security force are expected.

### FY-23 efforts

- Motion studies of Sentry-II ROWS configuration
- Force-on-force modeling to inform optimized ROWS placement for a proposed pilot study at a domestic nuclear power plant site
- Sniper performance testing at INL
- Graded approach to deployment (4 phases)
  1. Modeling and Simulation for ROWS placement
  2. Full-scope ROWS simulator to verify ROWS placement
  3. Limited-scope force-on-force exercises to validate ROWS strategy
  4. Full deployment of ROWS



Notional Visualization for Modeling ROWS Placement

## Visualizations from ROWS Modeling and Simulation



Notional Dante ViewShed Visualization Showing Double Firepower Coverage Areas on the Fictional Lone Pine Nuclear Power Plant Site for Modeling External ROWS Placements

## Unattended Openings (UAO)

**Impact:** Provide the technical basis to determine optimized protective strategies related to person-passible openings that intersect security boundaries during normal and maintenance operations. Reductions in patrols, monitoring, and compensatory measures are expected but will be site specific.

### FY-22 Efforts

- Identify human factors for males and females
- Conduct 2D UAO testing with circle, square, and rectangles
- Conduct 3D UAO testing with ~20-foot piping sections and expected pipe bends
- Considered dry and slippery surfaces
- Evaluated only horizontal openings
- Evaluated success of passing through the opening (go/no-go), rate times, and limited data on exertion
- Issued final performance-based, risk-informed report

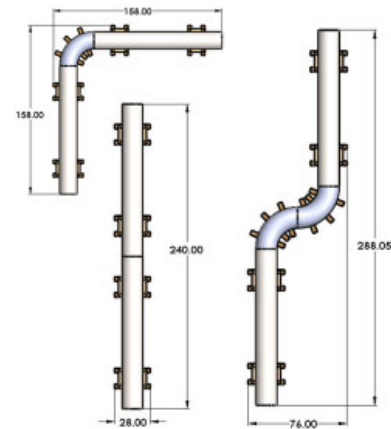

Example of 3D UAO Testing Configurations

## 2D Test Rigs

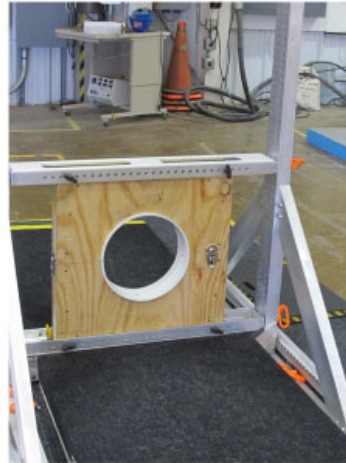

## 3D Test Rigs



## Deliberate Motion Analytics (DMA)

**Impact:** Security sensor fusion linked with DMA can take input from multiple sensors of different types, analyze the data, and determine if an adversary is making an approach toward a facility. Sites using current commercial sensor technologies typically experience elevated nuisance alarm rates (NAR) not caused by an intruder. Maintaining a low NAR while being able to detect intruders has the potential to decrease the cost of security.

### FY-23 Efforts

- Using DMA and sensor fusion, collect at least four weeks of continuous performance data at two nuclear power plant sites
- Consider un-engineered terrain (owner controlled area)
- Finalize an NPP-specific demonstration package containing sensor fusion

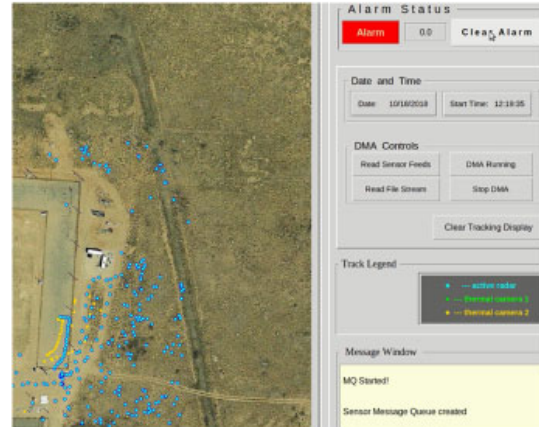

Active Radar (blue) and Thermal Camera (yellow) fused through DMA

## Sensors for Water Intakes

**Impact:** By fusing complementary sensors, DMA will create an intrusion detection system that will detect swimmers on or below the water's surface. DMA will analyze the fused data stream to determine if a waterborne adversary is making an approach toward a facility. This capability will leverage existing sensor technologies and ensure a low nuisance alarm rate.

### FY-23 Efforts

- Performance test candidate sensors
  - Passive sonar
  - Active sonar
  - Lidar
  - Bi-spectral video analytics
- Incorporate sensor outputs into DMA
- Complete pre-installation testing and check out (PITCO)
- Pilot study initial configuration at water intakes on a lake

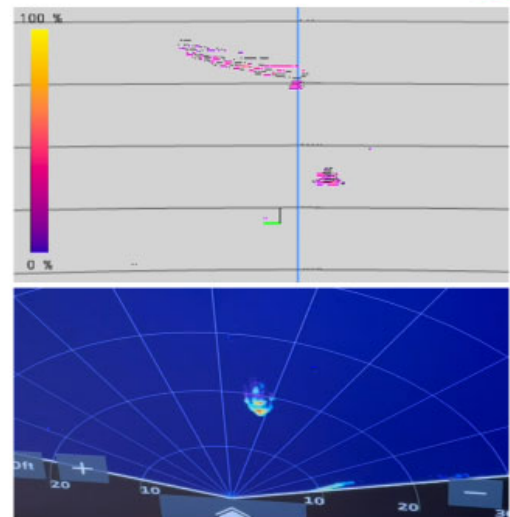

Lidar reflectivity point cloud of a surface swimmer (top)  
Sonar image of a surface swimmer (bottom)

## Sonar image of a swimmer

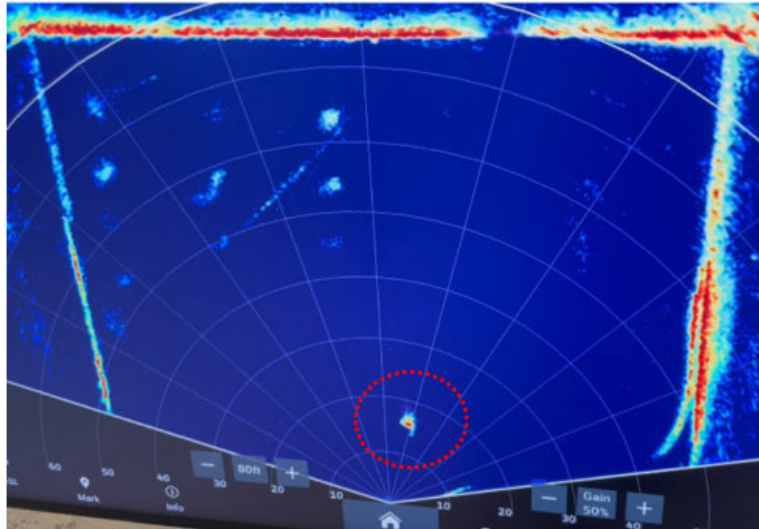

## Dynamic Risk-Informed Framework

**Impact:** A risk-informed physical security method integrating dynamic risk methods, physics-based modeling and simulation, operator actions, and FLEX equipment (as an example of safety equipment). This linked security-safety framework will extend the adversarial timeline for response force success. The tools will enable commercial utilities to incorporate increased realism in their force-on-force models, take credit for operator actions and FLEX equipment, and move toward greater use of quantitative measures of performance in security posture.

### FY-23 Efforts

- Confirm guidance in collaboration with stakeholders to support the use of the dynamic risk tools.
- Complete the integration of force-on-force simulation software platforms with thermal-hydraulic codes.
- Document Physical Security human reliability needs.
- Confirm dynamic modeling tools which incorporate force-on-force and operator actions into static and dynamic risk assessment models; credit additional operator actions and onsite mitigation equipment within a site's protective strategy.

## Risk-informed Consequence-based Security

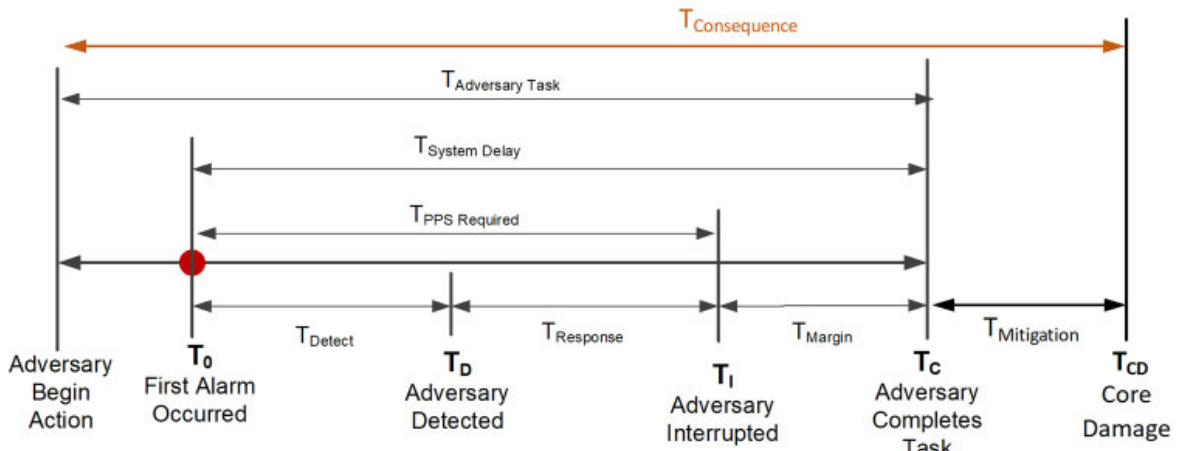

Security Analysis Timeline: Consequence-based Assessment

## CARBON Wireless

**Impact:** Provide secure, highly-reliable wireless communication links for nuclear security operations and applications. Influence policies as a role model for ideal wireless solutions in critical infrastructure applications; confidentiality, integrity, and availability (encryption, anti-tamper, and redundancy). Create a network solution with compatibility for legacy, current, and future wireless solutions.

### FY-23 Efforts

- Evaluate security applications of CARBON Wireless at nuclear utilities
  - Ability to disable compromised wireless/radio equipment
- Conduct a pilot study at one collaborating nuclear utility
  - Integration study with DMA

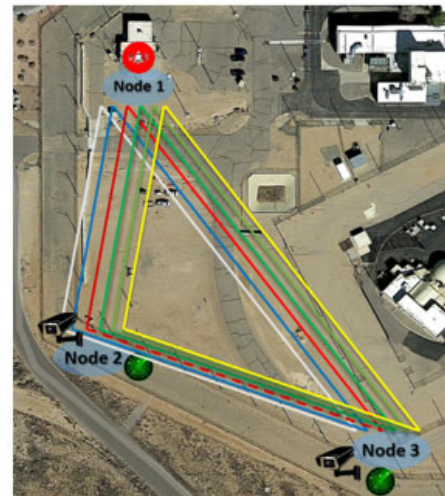

Example of CARBON Wireless nodes using multiple diverse underlay networks to transmit the same data streams

## Remote Operated Weapons System (ROWS)

**Impact:** Leverage an existing US Government ROWS solution for external and internal deployment at domestic nuclear power plant sites for an added force multiplier. Reductions in response force with increased survivability of overall security force are expected.

### FY-23 efforts

- Motion studies of Sentry-II ROWS configuration
- Force-on-force modeling to inform optimized ROWS placement for a proposed pilot study at a domestic nuclear power plant site
- Sniper performance testing at INL
- Graded approach to deployment (4 phases)
  1. Modeling and Simulation for ROWS placement
  2. Full-scope ROWS simulator to verify ROWS placement
  3. Limited-scope force-on-force exercises to validate ROWS strategy
  4. Full deployment of ROWS



Notional Visualization for Modeling ROWS Placement

## Sensors and Textiles Innovatively Tailored for Complex, High-Efficiency Detection (STITCHED)

STITCHED leverages a combination of existing and emerging technologies with electronic textiles capability. Using precise, computer-controlled embroidery, STITCHED technology fixes media such as wire, fibers, tubes, and optical fibers to fabric-like carrier materials. As a result, sensors can be embedded in a variety of multi-layer composites to enable highly specialized, low-cost, customizable sensing and transmission for national security applications. Applying this technology to R&D allows for high accuracy, efficient, large surface area coverage (ranging from 1" x 1" to 4' x 100') and simultaneous stitching of multiple media.

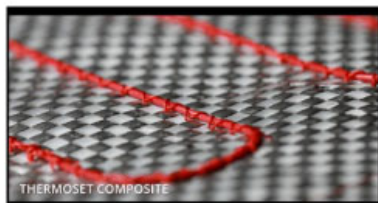

### POTENTIAL APPLICATIONS

-  Intelligent sensing for physical security
-  Specialized sensors and antennas
-  Custom designed EMI shielding
-  Embroidered RFID communications
-  Infrared and radiant heating and cooling
-  Multi-mode structural health monitoring
-  Enhanced test diagnostics and data acquisition
-  Autonomous systems
-  Energy harvesting
-  Biometrics and wearable sensors



## An Emerging Technology Full-Scope CAS Simulator

### Full-Scope CAS Simulator: An industry first in CAS Operator training



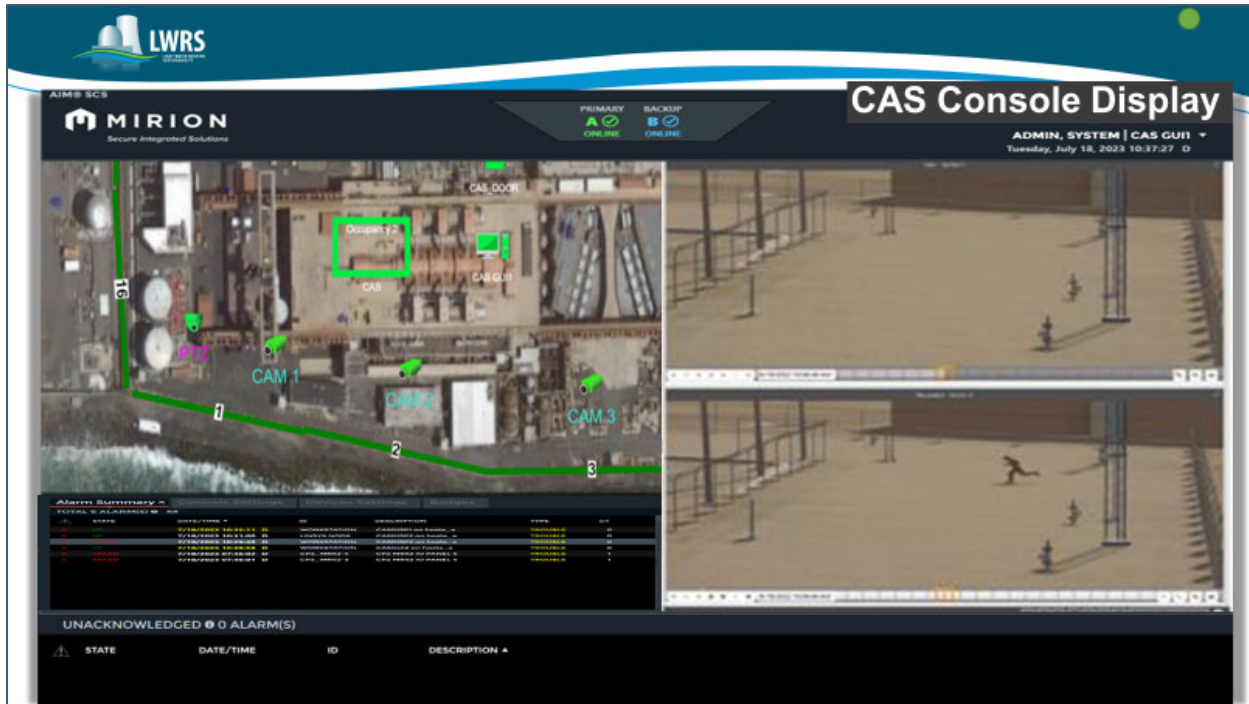

## CAS Simulator Scenarios: Camera & Video simulations



External threat through the PIDS  
(resolution of video minimized to save file size)

# Appendix E

## Materials Research



### Overview of Materials Research

**Objective:** provide data and methods to assess performance and damage mitigation options for systems, structures, and components essential to safe and economically sustainable nuclear power plant operations

**Approaches:** 1. Measurement of degradation, 2. Mechanisms of degradation, 3. Modeling and simulation, 4. Monitoring degradation, 5. Mitigation strategies, 6. Materials harvesting

**Outcomes:**

Reduce uncertainty at extended operation	Increase operational efficiency	Assess potential damage at extended operation	Reduce inspection and outage	Reduce costs and improve reliability
--	---------------------------------	---	------------------------------	--------------------------------------

**Partners:**

EPRI	NRC	Westinghouse	PWROG & BWROG	Many more...
------	-----	--------------	---------------	--------------

**Icons:** A blue circular icon labeled 'MANAGE AGING MATERIALS' with a cracked metal piece, and a green circular icon labeled 'REDUCE COSTS' with a dollar sign and a downward arrow.

2

## High Fluence Effect in Reactor Pressure Vessel (RPV)

- **Objectives:**
  - Study high fluence irradiation on RPV embrittlement and microstructure change
  - Develop mini-compact tension (mini-CT) test technique for direct fracture toughness measurements
  - Develop and implement new RPV embrittlement trend curve (ETC) for US LWR industry
- **Collaboration:**
  - University of California Santa Barbara, University of Wisconsin-Madison
  - ASTM and ASME
  - Westinghouse, PWROG, Energy Solutions, Holtec
  - EPRI, CRIEPI, EU FRACTESUS
  - EU STRUMAT-LTO

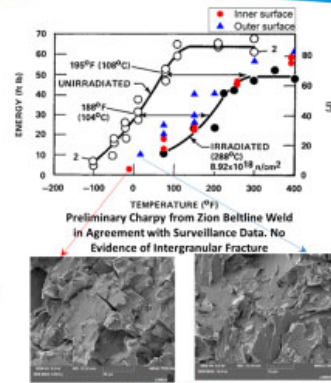

Fig. 1 Zion RPV testing

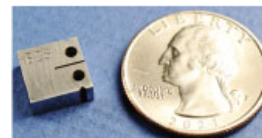

Fig. 2 Mini-CT specimen vs. US Quarter

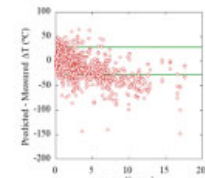

Fig. 3 EONY model underpredicts RPV high fluence embrittlement

3

## Irradiation Assisted Stress Corrosion Cracking (IASCC) of Austenitic Steels

- **Objective:**
  - Identifying mechanisms and mitigation strategies for IASCC of austenitic steels for LWR core components

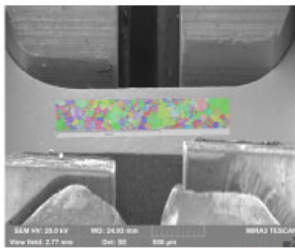

Fig. 1 In-situ tensile testing with SEM and EBSD on EDM machined miniature tensile specimens from harvested baffle former bolt

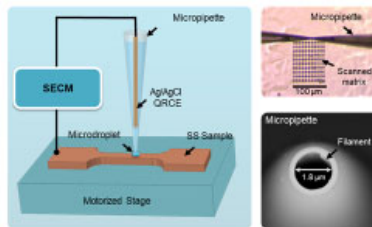

Fig. 2 Scanning electrochemical examination setup (SECM: scanning electrochemical cell microscopy)

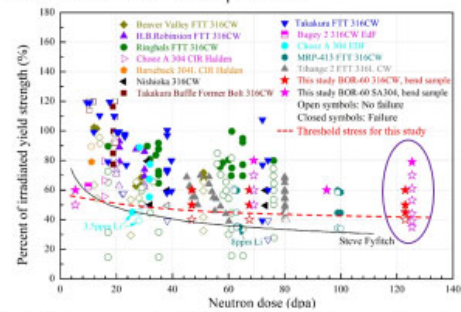

Fig. 3 Minimum stress for IASCC crack initiation in austenitic stainless steels in a PWR primary water environment

- **Collaboration:**
  - EPRI
  - Westinghouse

4

## Crack Initiation in Ni-Based Alloys

- **Objectives:**

- Identify underlying mechanisms controlling stress corrosion cracking (SCC) initiation and other long-term degradation modes (e.g., long-range ordering) that can potentially degrade SCC resistance in Ni-based alloys.
- Evaluate the impact of emerging technologies for sustaining reliable and economical operation of LWRs in terms of improving SCC resistance of Ni-based alloys

- **Collaboration:**

- NRC
- EPRI

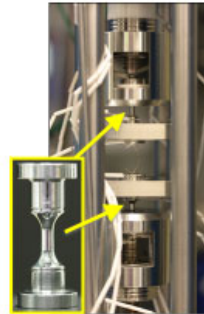

Fig. 1 SCC initiation & crack growth test system

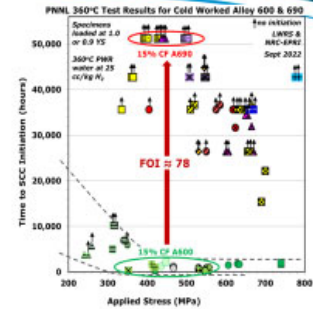
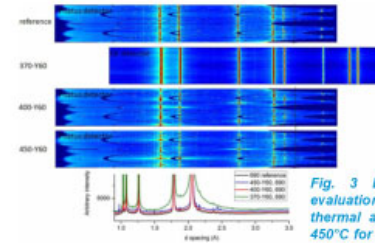

Fig. 2 Factor of Improvement (FOI) of 78 for SCC initiation in moderately cold worked Alloy 690 over moderately cold worked Alloy 600



5

## Weld Repair Techniques

- **Objective:**

- Develop advanced welding technology for weld repair of highly irradiated reactor internals to address a critical need facing the US nuclear industry for the life extension beyond 60 years

- **Collaboration:**

- EPRI
- BWXT

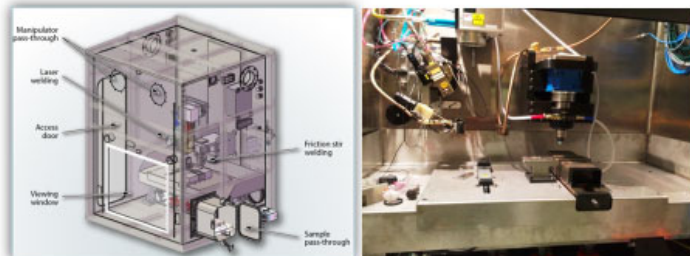

Fig. 1 Schematic (left) and actual photo (right) of friction stir welding and laser welding setup in hot cell

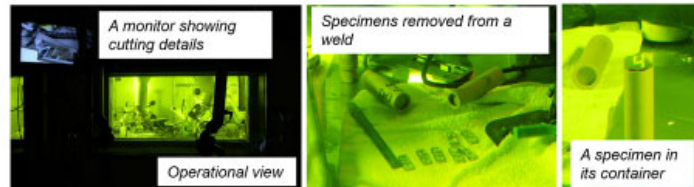

Fig. 2 Weld sample preparation inside hot cell for in-depth characterization

6

## Concrete Aging, Modeling, and NDE

- **Objectives:**

- Develop methodological guidelines to be used by industry for experimental and predictive assessment of irradiated concrete
- Assess the long-term performance of the concrete biological shield (CBS) under accidental conditions
- Provide a physics-based model for accurate prediction of the irradiated properties of concrete
- Develop new algorithms to analyze ultrasound data for defect detection
- Develop a machine learning model to detect expansion in concrete

- **Collaboration:**

- EPRI
- NRC and DOE-NSUF
- Japan Concrete Aging Management Program (JCAMP)

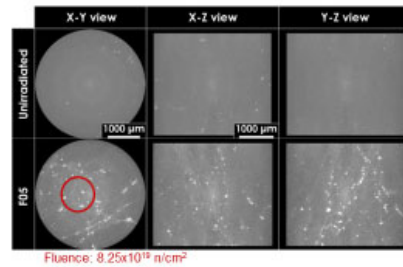

Fluence:  $8.25 \times 10^{19}$  n/cm<sup>2</sup>

Fig. 1 Void formation on irradiated concrete aggregate

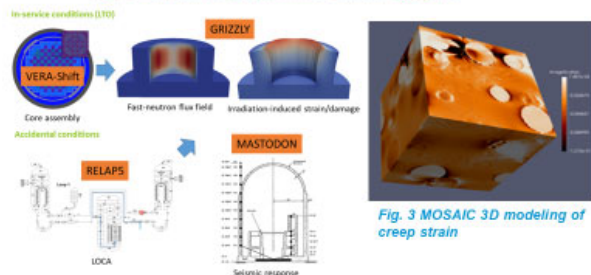

Fig. 3 MOSAIC 3D modeling of creep strain

Fig. 2 Assess CBS performance under LOCA and seismic events

## Cable Aging and Cable NDE

- **Objectives:**

- Understand limitations of accelerated aging and interpret cable condition monitoring signals
- Increase effectiveness of non-destructive cable health measurement
- Develop advance technologies for online cable condition monitoring

- **Collaboration:**

- University of South Carolina
- University of Utah and LiveWire
- Kinectrics
- NRC, EPRI, industry, and universities



Fig. 1 ARENA Cable Test Bed

- Activation Energy Values  
M3LW-21OR0404017
- Diffusion Limited Oxidation  
M3LW-21OR0404016
- Synergistic Effects  
M3LW-21OR0404015
- Sequential vs Concurrent Aging  
M3LW-21OR0404015
- Inverse Temperature Effects (FY22)  
M3LW-22OR040401
- Dose Rate Effects (FY23)  
In-Progress

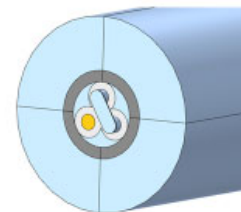

Fig. 3 General Cable, 3-conductor low-voltage electrical cable digital twin model

Fig. 2 EMDA cable aging knowledge gaps

## Recent Accomplishments:

### Evaluation of stress corrosion cracking (SCC) initiation and growth of Ni-based alloys in LiOH vs. KOH PWR Primary Water

- Objective:**

- Support US PWR industry by evaluating the feasibility of replacing LiOH with KOH for pH control in PWR primary water

- Accomplishments:**

- SCC growth rate tests completed for Alloy X-750 and Alloy 718. Both materials exhibited similar SCC growth rates during on-the-fly changes between various KOH- and LiOH-containing water chemistries
- SCC initiation and growth rate tests for Alloy 82 are ~80% completed. A slight delay of SCC initiation in the KOH-containing water chemistry was observed while similar SCC growth behaviors were observed between KOH- and LiOH-containing water chemistries
- Results support switching from LiOH to KOH for pH control in PWR primary water



Fig. 1 SCC growth test setup

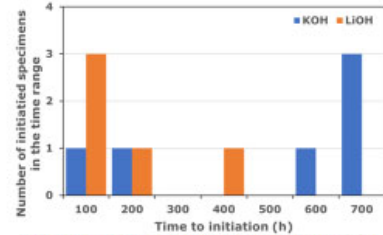

Fig. 2 Delay of SCC initiation for Alloy 82 in KOH compared with LiOH

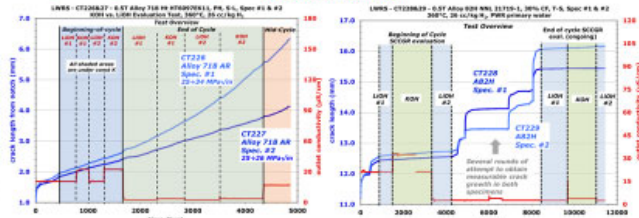

Fig. 3 Similar SCC growth behaviors of Alloy 718 (left) and Alloy 82 (right) in KOH vs. LiOH

## Recent Accomplishments:

### Towards developing experimental methodological guidelines to assess radiation damage in concrete

- Objective:**

- Quantify radiation induced porosity/cracks with dimensions > 1 micron in neutron irradiated aggregates of different mineralogy shared by the JCAMP team

- Accomplishments:**

- 24 irradiated samples of different mineral aggregates shipped to Argonne National Laboratory to perform microtomography at the Advanced Photon Source (APS) to measure potential pores and cracks inside the material
- The group of materials contains samples irradiated to 4 different neutron doses representing prolonged operation of LWRs for each rock type
- Understanding the amount of cracking in aggregate of different mineralogy is crucial to accurately model residual mechanical properties and damage on concrete after prolonged irradiation

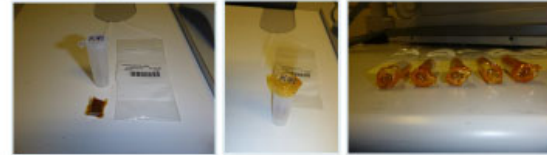
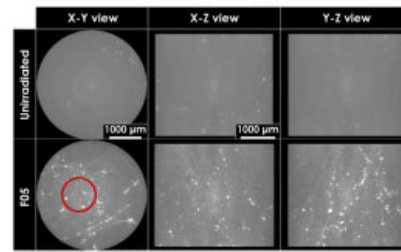

Fig. 1 Samples shipped for APS tomography measurements



Fluence:  $8.25 \times 10^{13} \text{ n/cm}^2$   
Fig. 2 Void formation on irradiated concrete aggregate

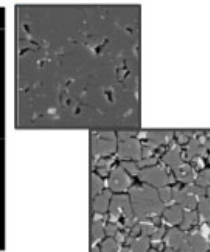

Fig. 3 SEM of the pristine (top) and irradiated (bottom) meta-chert samples showing grain boundary cracking (Maruyama et al. 2022)

## Materials Research Planned Multi-year Outcomes

RPV



1. Harvest high fluence A-60 Palisades surveillance capsule (FY23)
2. Develop embrittlement trend curve (FY25)

Core internal and pressure boundary

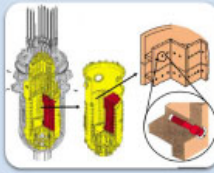

1. Complete long-term thermal aging on Alloy 690 and its weldment (FY23)
2. Complete feasibility study for replacing LiOH with KOH (FY23)
3. Complete long-term SCC initiation testing of alloy 690 (FY25)
4. Complete long-term SCC initiation testing on blunt notch high Cr Ni-based weld metals (FY25)

Mitigation

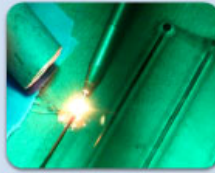

1. Develop advanced welding technology, including laser and friction stir welding (FY25)
2. Complete timeline/roadmap for ASME code development in collaboration with EPRI (FY25)

Concrete

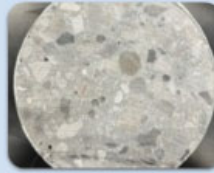

1. Develop code to improve Microstructure Oriented Scientific Analysis of Irradiated Concrete (MOSAIC) parallelization capabilities to enable large 3D simulations (FY23)
2. Develop methodological guidelines for industry for experimental and predictive assessment of irradiated concrete (FY23)

Cable



1. Consolidate the status of the Cable Expanded Materials Degradation Assessment (FY23)
2. Extend Spread Spectrum Time Domain Reflectometry (SSTDR) bandwidth and test, and use the ARENA test bed for thermal aging, ground fault, and water detection (FY23)



# Appendix F

## Briefing Paper on Evaluation of ION Cost Reduction Opportunities for LWRs Program Pathways

Briefing Paper

Author: Jason Remer  
September 2023



### Complete Evaluation of ION Cost Reduction Opportunities for LWRs Program Pathways

#### Purpose of this Study

It is the purpose and mission of the integrated operations for nuclear (ION) business model and research effort at LWRs to identify and integrate technological and programmatic changes and modernizations to nuclear plant operations. These changes, called work reduction opportunities (WROs), are advanced and integrated into the ION model then verified and explored further in applied ways with partnering utilities and plant sites. As the ION model gains structure, researchers look to add new WROs as components to the existing WRO suite from ongoing research within the LWRs group. Each pathway in the LWRs Program was evaluated and interviews conducted with each pathway led to extracting current and future research and development (R&D) that could lead to the development of new work reduction activities.

#### Scope of this Study

The Light Water Reactor Sustainability (LWRs) Program, sponsored by the U.S. Department of Energy and coordinated through a variety of mechanisms and interactions with industry, vendors, suppliers, regulatory agencies, and other industry R&D organizations, researches to develop technologies and other solutions to improve economics and reliability, sustain safety, and extend the operation of nation's fleet of nuclear power plants.

**The LWRs Program has two objectives to maintain the long-term operations of the existing fleet:**

1. To provide science and technology-based solutions to industry to implement technology to exceed the performance of the current business model; and
2. To manage the aging of systems, structures, and components so nuclear power plant licenses can be extended and the plants can continue to operate safely, efficiently, and economically.

The LWRs Program R&D pathways are:

- **Plant Modernization** – R&D to address nuclear power plant economic viability in current and future energy markets through innovation, efficiency gains, and business model transformation using digital technologies.
- **Flexible Plant Operation and Generation** – R&D to identify opportunities and develop methods for light-water reactors (LWRs) to directly supply energy to industrial processes to diversify approaches to revenue generation.
- **Risk-Informed Systems Analysis** – R&D to develop and deploy risk-informed tools and methods to achieve high levels of safety and economic efficiencies.
- **Materials Research** – R&D to develop the scientific basis for understanding and predicting long-term environmental degradation behavior of materials in nuclear power plants.
- **Physical Security** – R&D to develop methods, tools, and technologies to optimize and modernize a nuclear facility's security posture.



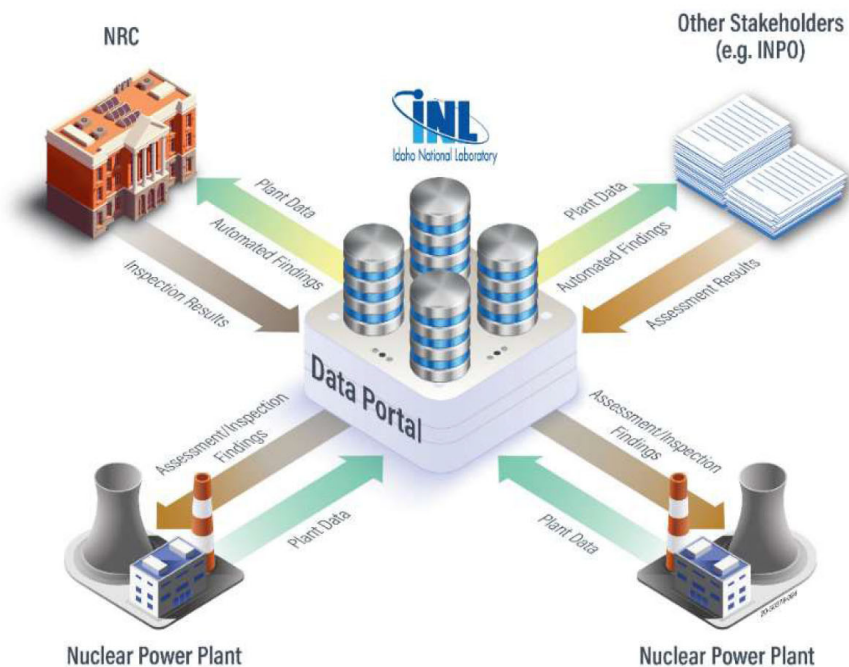

**Results of this Study**

Based on interviews with LWRS pathway leads and a review of current and future R&D plans, the following significant areas of research were identified as having potential to improve the economic performance of the plants through direct cost reduction or addressing pressing operational issues that would require additional capital or operations and maintenance (O&M) investment in the future. Generation 1 WRO’s are identified as those items that could be implemented within 3 to 5 years and Generation 2 WRO’s are those with a longer time horizon that could be implemented within 5 or more years.

Research Areas	Research Title	Implementation Timing
Plant Modernization	Modernization of Field-End Digital Infrastructure (1.1.1)	Generation 1 (3–5 years)
	Data Capture and Visualization (1.1.2)	Generation 1 (3–5 years)
	Integrating Artificial Intelligence and Machine Learning with Sensor Deployment (1.1.3)	Generation 1 (3–5 years)
	Use of Enterprise Data for Operational Decision-Making (1.1.4)	Generation 1 (3–5 years)
	Developing a Business Case Concerning the Economic Benefits of Reducing Maintenance Frequencies (1.1.5)	Generation 1 (3–5 years)
Flexible Plant Operations & Generation	Use of Nuclear Plants to Produce Hydrogen (1.2.1)	Generation 1 (3–5 years)
	Expansion of Steam Production and Accessing the Markets for Thermal Energy (1.2.2)	Generation 2 (5 or more years)

Research Areas	Research Title	Implementation Timing
	Using Gasification to Turn Black Liquor into Fuel (1.2.3)	Generation 2 (5 or more years)
Risk Informed Systems Analysis	Risk-Informed Asset Management (1.3.1)	Generation 1 (3–5 years)
	Risk-Aligned Data-Driven Compliance (1.3.2)	Generation 1 (3–5 years)
	Evaluations of Accident-Tolerant Fuel (ATF) with Higher Burnup (1.3.3)	Generation 1 (3–5 years)
	Plant Reload Optimization (1.3.4)	Generation 1 (3–5 years)
	Risk Assessment of Digital I&C Systems (1.3.5)	Generation 1 (3–5 years)
	Enhanced Fire PRA (1.3.6)	Generation 1 (3–5 years)
	AI Supported LiDAR (1.3.7)	Generation 1 (3–5 years)
	Risk-Informed Aging Management and Subsequent License Renewal (SLR) (1.3.8)	Generation 1 (3–5 years)
Physical Security	Augmented Reality for Force-on-Force Exercises (1.4.1)	Generation 1 (3–5 years)
	Advanced Sensors Unique to Nuclear Power Plants (1.4.2)	Generation 1 (3–5 years)
	Performance Based Probabilistic Risk Assessment for Security (1.4.3)	Generation 1 (3–5 years)
	Remote Operated Weapons (1.4.4)	Generation 1 (3–5 years)
Materials Research	Predicting the Embrittlement Trend Curve for Reactor Pressure Vessels Under High Fluence Conditions in Extended Operations (1.5.1)	Generation 2 (5 or more years)
	Thermal Annealing of Reactor Pressure Vessel (1.5.2)	Generation 2 (5 or more years)
	Address potential concern of stress corrosion cracking on a high chromium and nickel-based alloy 690 (1.5.3)	Generation 2 (5 or more years)
	Replacing Lithium Hydroxide with Potassium Hydroxide for Water pH Control (1.5.4)	Generation 1 (3–5 years)
	Concrete Performance / Degradation After Irradiation (1.5.5)	Generation 2 (5 or more years)
	Developing an Effective Cable Condition Monitoring Program (1.5.6)	Generation 2 (5 or more years)

### Potential WROs for Near-Term Focus

While much of the research presented in this research will have an impact on the domestic nuclear industry, there are standout efforts researchers feel will have a positive effect on nuclear power plant O&M costs and that utilize technological changes that represent the best of IONs value. Industry expects new ideas and projects to consider for their ION transformations, therefore the following LWRS research projects are highlighted to be considered for inclusion in the suite of ION WROs.

1. Modernization of Field-End Digital Infrastructure
2. Data Capture and Visualization
3. Integrating Artificial Intelligence and Machine Learning with Sensor Deployment
4. Use of Enterprise Data for Operational Decision-Making

5. Risk-Informed Asset Management
6. Augmented Reality for Force-On-Force Exercises
7. Advanced Sensors Unique to Nuclear Power Plants
8. Performance-Based Probabilistic Risk Assessment for Security
9. Remote Operated Weapons
10. Replacing Lithium Hydroxide with Potassium Hydroxide for Water pH Control

### Future Areas for Research and Development

ION is focused on plant operations and the implementation of technology and process change to drive sustainable business models. With this objective in mind, some areas of plant operation deserve attention from the research community. The following list will highlight some of these areas and possible research pathways.

- Project management and project estimating – Research into the process of estimating plant modifications and process upgrades at nuclear plants may be productive. Project management is also ripe for new processes.
- Knowledge retention – There is a multitude of non-proceduralized practices, skills, and even customs at a nuclear plant that are essential to the efficiency of that plant and the overall health of outages, work groups, and other aspects of work (i.e., material staging and laydown area organization). Research into the transmittal of these practices, skills, and customs to the incoming cohort may bear fruit in easing the transition from experienced workers to those who are new to the discipline.
- Configuration management – Configuration management at plant sites is an essential practice and discipline. Without accurate design bases, engineers risk design errors, maintenance planners risk work package errors, and operators risk clearance errors. Research may be able to quantify this risk and come up with time-saving solutions not only to the current population of un-updated drawings, but to the entire configuration management process of mark-ups, drawing revision, review, approval, and document processing.

### Contact

S. Jason Remer | 202-431-8204 | [Jason.Remer@inl.gov](mailto:Jason.Remer@inl.gov)

Zachary Spielman | 208-520-8357 | [Zachary.Spielman@inl.gov](mailto:Zachary.Spielman@inl.gov)

More on the LWRS Program: <https://lwrs.inl.gov/>

### References

Complete Evaluation of ION Cost Reduction Opportunities for LWRS Pathways (INL/RPT-23-74595)