

Light Water Reactor Sustainability Program

Preconceptual Designs of 50% and 70% Thermal Power Extraction Systems



March 2024
U.S. Department of Energy
Office of Nuclear Energy

DISCLAIMER

This information was prepared as an account of work sponsored by an agency of the U.S. Government. Neither the U.S. Government nor any agency thereof, nor any of their employees, makes any warranty, expressed or implied, or assumes any legal liability or responsibility for the accuracy, completeness, or usefulness, of any information, apparatus, product, or process disclosed, or represents that its use would not infringe privately owned rights. References herein to any specific commercial product, process, or service by trade name, trade mark, manufacturer, or otherwise, does not necessarily constitute or imply its endorsement, recommendation, or favoring by the U.S. Government or any agency thereof. The views and opinions of authors expressed herein do not necessarily state or reflect those of the U.S. Government or any agency thereof.

Preconceptual Designs of 50% and 70% Thermal Power Extraction Systems

Tyler Westover, Jeffrey A. Brown
Idaho National Laboratory

Henry Fidlow, Henry Gaudin, Jack Miller, Keith Miller, Gabriel Neimark,
Nic Richards
Sargent & Lundy

March 2024

Idaho National Laboratory
Light Water Reactor Sustainability
Idaho Falls, Idaho 83415

<http://lwrs.inl.gov>

Prepared for the
U.S. Department of Energy
Office of Nuclear Energy
Under DOE Idaho Operations Office
Contract DE-AC07-05ID14517

EXECUTIVE SUMMARY

Background

The Light Water Reactor Sustainability (LWRS) program conducts research to develop technologies and other solutions to improve the economics and reliability, sustain the safety, and extend the operation of the US domestic fleet of nuclear power plants. The program is comprised of several research and development sub-programs, or “pathways,” including the Flexible Plant Operation and Generation (FPOG) pathway. The FPOG pathway provides research and development to evaluate economic opportunities, technical methods, and licensing needs for light water reactors to directly supply thermal and electrical energy to co-located or adjacent industrial processes. This pathway adapts and uses analytical tools developed by the US Department of Energy (DOE) to complete technical and economic assessments of large, realistic market opportunities for producing nonelectrical energy products. Carbon emissions from large-scale non-electric energy applications, such as hydrogen production, chemical synthesis, and petroleum refining can be substantially reduced by using heat and electricity sourced from clean nuclear power.

The LWRS-FPOG pathway specifically provides engineering design, testing, and demonstration of the integration of nuclear power plants with industrial processes. Design activities include feasibility assessments for nuclear plant modifications to divert thermal power (steam) from the plant secondary system. Sponsored by the FPOG pathway, the engineering consulting firm Sargent & Lundy (S&L) has completed an initial plant system performance predicated on thermal power dispatch (TPD) of 30%, 50% and 70% of the reactor thermal power from the main steam line from a generic Westinghouse 4-loop pressurized light water reactor (PWR). The Westinghouse design is considered representative of most domestic PWRs for the purposes of assessing the potential impacts of TPE on major PWR systems, structures, and components.

S&L has estimated the impacts on secondary system performance using the PEPSE thermal performance modeling software. The model results are presented in report SL-017758 Rev 02 and are appended to this Executive Summary. Table 1 summarizes the PEPSE results for four (4) extraction scenarios: (1) 30% TPD, (2) 50% TPD, (3) 50% TPD with 20% condensate bypass of the low-pressure (LP) feedwater heaters (FWHs), and (4) 70% TPD.

The S&L report includes an engineering assessment of the impacts to the PWR secondary system based on the PEPSE results for the respective TPD scenarios. Of particular interest are the impacts on the plant equipment due to thermal and mechanical stresses associated with thermal power extraction. The assessment concludes that the plant would be expected to reasonably accommodate up to 50% thermal power extraction without significant impact to major components, including the high- and low-pressure turbines, main condenser, power train pumps, moisture separator reheaters, drain systems, feedwater heaters, and extraction steam.

However, the 70% TPD assessment has identified potential challenges for both the secondary plant and the Nuclear Steam Supply System (NSSS). Plant specific analysis would be expected to demonstrate that the necessary redesign and modifications for 70% TPD would be significant and thermal power dispatch at this capacity would likely not be a cost-effective option for PWRS within the existing U.S. nuclear fleet. A summary of the evaluation assessments as a function of TPD follows.

Table 1. General impacts for thermal power dispatch scenarios

Description	Units	Baseline 0%	Case #1 30% TPD	Case #2 50% TPD	Case #3 50% TPD with bypass	Case #4 70% TPD
Generator electric power	MWe	1,228.00	844.6	585.3	573.1	327.3
Thermal power extracted	MWt	0	1,095	1,827	1,826	2,557
% of MS flow directed to TPD	%	0	21.9	37.6	37.7	55
MS flow from SGs	lbm/hr	16,037,390	15,436,290	14,952,560	14,916,170	14,316,180
HP turbine inlet flow	lbm/hr	15,218,400	11,272,260	8,615,524	8,619,505	5,893,152
HP turbine 1st stage pressure	psia	651.5	487.5	374.8	375.2	260.4
MSR inlet pressure	psia	190.3	140.2	104.6	97.6	65.5
LP turbine inlet flow	lbm/hr	3,673,069	2,677,248	1,980,267	1,845,837	1,230,440
LP turbine inlet pressure	psia	175.5	129.3	96.43	90.04	60.4
Condenser duty	BTU/hr	8.21E+09	5.78E+09	4.18E+09	4.22E+09	2.57E+09
Condensate pump flow	lbm/hr	11,334,490	11,723,820	11,889,450	11,475,500	11,900,900

Abbreviations: HP = high pressure; LP = low pressure; MS = mains steam; MSR = moisture separator reheater; SG = steam generator.

30% Thermal Power Dispatch

An assessment of the impacts on the plant secondary system at 30% TPD concludes that most major component performance would remain within the design limits and for specific localized impacts, component upgrades and inspection could reasonably accommodate any adverse operating condition.

Engineering evaluations suggest that high-pressure/low-pressure (HP/LP) turbine and moisture separator reheater (MSR) performance is very similar to that expected when the plant is operated at 75% of rated power. The plant would be expected to be able to sustain operation at 30% TPD for long durations. Similarly, condenser operating conditions are expected to continue to meet operation requirements and without impact to evacuation capacity. There are minimal impacts on the power train pumps and replacement would not be anticipated.

For 30% TPD, assessment of the feedwater heaters concludes that tube degradation and or nozzle wear is not expected to limit dispatch operation, although heater shell wear patterns could be affected resulting in increased degradation. Tube-side pressure drop for the 30% TPD case is not expected to

appreciably impact reliable operation of the heaters. Drain inlet mass fluxes remain bounded by industry guidance. However, mass flux parameters for specific heaters were shown to exceed guidelines and could result in increased wear rates. Operating temperatures and pressures decreased for all feedwater heaters, increasing design margin. Volumetric flow through all drain coolers is also expected to decrease, resulting in increased margin for tube vibration parameters.

Analysis of the extraction steam system shows that overall, extraction steam line pressure drops increase due to higher flow velocities. The increased flow velocities should be included in the individual station Flow Accelerated Corrosion (FAC) program to ensure that any potential degradation is properly monitored and addressed. Expansion joint liner thickness requirements also increased. Replacement of expansion joints may be needed to ensure requirements are met during TPD operations. As a result of pressure and temperature decreases with 30% TPD operating condition margins largely improved in the extraction steam system.

Heater drain tanks are expected to operate normally at 30% TPD. Feedwater heater (FWH) drain control valves (DCVs) will require greater flow passing capability and is expected that a plant specific review may find that replacement of the FWH 2 and 3 DCVs is necessary due to significant increase in required valve flow coefficient (CV) when operating with 30% TPD.

The overall impact on material degradation, material properties, and fatigue under the 30% TPD scenario is expected to be limited to specific locations and conditions. Based on the PEPSE model results, most components would be subject to reduced temperatures, pressures, and flows. Consequently, the secondary system components would not be negatively affected by TPD up to 30%. No temperature or pressure related impacts on materials were noted in the evaluation data which would be expected to impact material properties or result in an unacceptable increase in the risk of fatigue related issues.

Equipment that receives the feedwater (i.e., steam generator) from the feedwater heaters will receive water at a lower temperature, however this temperature reduction (27.6°F lower) does not result in a significant impact on the material properties of this equipment. Impact of thermal cycling due to changes in plant operations and level of TPD would be expected to be minimal due to the small temperature delta from normal operations.

50% Thermal Power Dispatch

The assessment of the HP/LP turbine and MSR performance at 50% TPD concludes similar results to the performance evaluation at 30% TPD. Steam turbine and MSR operation would remain within the design operating profile. Nevertheless, original equipment manufacturer (OEM) review should be performed to verify acceptability. There are minimal impacts to condenser operating conditions and power train pumps, therefore no changes are expected to this equipment.

The thermal-hydraulic assessment demonstrates that the operating condition (temperature, pressure, and tube vibration) result in increased margins for all feed water heaters (FWHs). However, operation at 50% TPD (with and without partial LP FWH bypass) will result in an increase in tube and tube-side nozzle velocities, albeit the increase in wear would be marginal and not expected to result in unacceptable increases in degradation. Similarly, increases in steam inlet nozzle velocities could affect wear patterns on the heater shells but are likewise considered manageable. FAC program impacts should be evaluated for potential increases in wear rate and inspection frequency.

Tube side pressure drop and drain inlet mass fluxes face minor impacts, while the mass flux parameters for various heaters exceed guidance with no LP FWH bypass; partial LP FWH bypass resolves this issue. Collectively, the impacts on the FWHs at 50% TPD are not expected to significantly

challenge the heater operational life resulting in premature replacement. However, enhanced inspections will be necessary.

Analysis of the extraction steam system shows extraction steam line pressure drops increase due to velocity increases. Expansion joint liner thickness requirements may also increase, while operating conditions would improve. Existing expansion joints would need to be evaluated on a plant-specific basis and may require replacement.

Heater drain tanks are expected to operate normally under 50% TPD. However, with no LP FWH bypass, normal FWH 2 drains are incapable of passing the required flow and multiple FWH drain control valves (DCVs) may require greater flow passing capability through either replacement or emergency dump to the condenser. Station specific review of the FWH 2 and 3 DCVs, and potentially the FWH 4 DCVs, would be expected to require replacement for these valves if operating without bypass. Conversely, with the implementation of partial LP FWH bypass, the increase in required flow capacity is significantly reduced and valve replacement is not expected to be required. The bypass modification would cause a small decrease in electric power generation (approximately 12 MWe). These scenarios are required to be evaluated in more detail on a site-specific basis in order to assess which is the preferred option. Additionally, other options may be explored to decrease pressure drop such as drain line resizing.

The secondary system impacts for 50% TPD are amplified compared to those for 30% TPD. The impact on material degradation, material properties, and fatigue is estimated to be greater on the FWHs, extraction steam, and FWH DCVs. Equipment that receives the feedwater (i.e., steam generator) from the Feedwater Heaters under the 50% extraction scenarios will receive water at a lower temperature; however, this temperature reduction (51.9°F to 53.8°F lower) would not be expected to result in a large negative impact on the material properties of this equipment. As with the 30% TPD evaluation, the impact of thermal cycling due to changes in plant operations and level of TPD would be expected to be minor due to the temperature delta from normal operations. The areas which could exhibit increases in flow related wear at 50% extraction should also be subject to increased inspections and inclusion of the site specific FAC programs.

70% Thermal Power Dispatch

Evaluation of the HP/LP turbines and MSRs for 30% and 50% extraction showed performance to be similar to the 75% and 50% power cases, respectively. While not explicitly performed here, it is expected that this equipment will perform similarly to a 25% power case. Nevertheless, OEM review would be necessary.

Detailed assessment of the condenser and power train pumps is also not a focus for 70% TPD, since the impacts under 30% and 50% TPD were relatively minor compared to the other equipment evaluated. Major replacement of these components is not expected, but evaluation will be required on a site-specific basis. FWH and drain cooler tube and nozzle velocity increases are relatively minor but may impact shell wear patterns. Steam inlet nozzle velocities exceed HEI guidelines for the 2nd, 3rd, 4th, 5th, and 6th point heaters, and drain inlet mass flux parameters for various heaters exceed the guidelines. Both of these impacts indicate potential over-stressing of the impingement plates. FAC evaluation would additionally be required to determine the extent of impacts to shell wear rates. This is an additional indicator that the impingement plates are at risk for structural damage under 70% TPD conditions. Operating condition (temperature, pressure, and tube vibration) margins improve for all FWHs. Nevertheless, formal site-specific evaluation would be required to assess whether FWH replacement is needed due to increased flow velocities.

Analysis of the extraction steam system shows extraction steam line pressure drops increase due to greater velocities, with lines to the 3rd, 4th, and 5th stage feedwater heaters seeing increases of over 150%. Expansion joint liner thickness requirements also increase, while operating conditions largely improved. Existing expansion joints would need to be evaluated on a plant-specific basis and may require replacement.

The Heater Drain system experiences a reduced flow under the 70% extraction scenario and is expected to operate normally under 70% TPD. However, normal FWH 2 and 3 drains are incapable of passing the required flow and multiple FWH DCVs may require greater flow passing capability through either replacement or emergency dump to the condenser. Station specific review of the FWH 2, 3, and 4 emergency DCVs and the FWH 4 normal DCV would be needed, along with operational changes to address the CV limitations of the FWH 2 and 3 normal DCVs.

At 70% extraction, some impacts noted under the 30% and 50% extraction scenarios are increased and some decreased. The impact on material degradation, material properties, and fatigue were found to be greater in most cases. The equipment receiving feedwater (i.e., steam generator) from the FWHs under the 70% TPD scenario will receive water at a temperature well below (86.9°F lower) the baseline (0% TPD) scenario. This temperature delta is not expected to result in a large impact on the equipment material properties but should be evaluated for station specific conditions. The impact of thermal cycling due to changes in plant operations and level of thermal extraction would be expected to be acceptable based on temperature and pressure deltas from normal operations.

Investigation of the items of concern for 70% shows that going above 50% TPD will prove challenging on plant systems – both on the balance of plant side as well as potential NSSS impacts – and is not expected to be cost effective option for the existing U.S. nuclear fleet. Nevertheless, the extraction of up to 50% thermal power remains a feasible option for these plants.

The results described herein are based on a generic reference plant and PEPSE model, therefore the conclusions of site-specific evaluation may differ from this generic PEPSE model analysis and equipment assessment based on plant/equipment design, operation, and age. Detailed evaluation of the NSSS impacts was also not performed. Plant specific evaluation of core/plant response and equipment would be required for any station considering a modification of the type described in this study.

INDUSTRY REVIEW AND COMMENTS

Nuclear power utility personnel have reviewed the attached report SL-017758, Heat Balance Model Analysis and Equipment Assessment for 30%, 50%, and 70% Thermal Power Extraction from a Nuclear Power Plant, Revision 2 and provided the following comments in an effort to ensure LWRS-FPOG program objectives are achieved and that the program deliverables provide useable guidance for the initial concept development for the subsequent design of integrated energy systems with existing nuclear plants.

Comment 1 - This report addresses the potential mechanical impacts on major secondary system components resulting from a range of thermal power (steam) extraction values from the main steam line of a typical PWR. Qualitative assessment of these impacts based on the estimated changes in secondary system operating conditions defines possible extraction limitations and design constraints and provides a bases for establishing an initial conceptual extraction system capacity. This objective is not concisely stated in the report, and it should clearly indicate that the report is not intended or sufficiently developed to support design bases analysis. The scope of work should provide more detail and should also include a statement of analysis limitations.

Comment 2 – The report also includes some minor consideration of potential plant impacts including mechanical transients (thermal cycling), high-energy line break (HELB), hydraulic transients (water/steam hammer), and reactivity and control system response. These notes are provided only as a recognition that these areas require further development in site-specific studies.

Comment 3 - The Model Design section states that “this design [Westinghouse 4-Loop] was selected to be applicable to the greatest number of existing nuclear plants.” The evaluation of a PWR secondary system, specifically the mechanical system components, is more generic and the report should consider the design to reasonably representative of all US PWR secondary systems. The report could be improved by indicating where specific differences between the various NSSS vendor designs would have a measurable impact (if any) on the feasibility assessment results.

Comment 4 – Analysis of the plant secondary system response to steam extraction from the high-pressure steam line is based on PEPSE models that assume that the thermal power remains constant through the steam generator between normal operations and TPD at the various percent levels. This is a reasonable boundary condition since the reactor and turbine control systems will establish a new operating point at full reactor output. However, TPD will substantially reduce the heat load on the condenser. The circulating water and plant cooling systems will, depending upon design, return substantially cooler water that could impact the thermal stresses across the condenser.

Comment 5 – Detailed operating experience presented in Section 3.4 should provide a synopsis of all relevant OE findings that provide data to substantiate the feasibility assessment conclusions for operation with thermal power extraction.

Comment 6 – The report should also include some consideration or guidance for other secondary system impacts attributed to steam extraction (see Comment 2). These include the potential for induced flow oscillations in the secondary system, flow induced vibrations in the mechanical systems, and thermal stratification and high-cycle fatigue. Also, a discussion on the system design and compliance with ASME B31.1 should be included.

As an example, modification of the main steam header to accommodate the extraction piping and isolation valve(s) results in new piping geometry subject to vortex shedding and flow induced vibrations. This assessment assumes that the design team will design according to industry standards and practices to

preclude, to the extent possible, hydraulic instabilities and consequential mechanical system impacts (e.g., flow induced vibration, thermal stratification, etc.). Plant specific installations must include system post-modification testing to ensure that the design remains within limits during all operational modes.

Heat Balance Model Analysis and Equipment Assessment for 30%, 50%, and 70% Thermal Power Extraction from a Nuclear Power Plant

SL-017758

Revision 2

January 26, 2024

Project No.: 14248.011

S&L Nuclear QA Program Applicable:

Yes

No

55 East Monroe Street
Chicago, IL 60603-5780 USA
312-269-2000
www.sargentlundy.com



Report prepared for the Light Water Reactor Sustainability (LWRS) Program at Idaho National Laboratory (INL) under the direction of Richard Boardman and Tyler Westover. The views and opinions of authors expressed herein do not necessarily state or reflect those of the U.S. Government or any agency thereof.

VERSION LOG

Version	Issue Date	Sections Modified
0	June 1, 2023	Initial Issue
1	November 17, 2023	Added 50% TPE
2	January 26, 2024	Added 70% TPE

ISSUE SUMMARY AND APPROVAL PAGE

This certification page conveys that this document has been prepared, reviewed, and approved in accordance with Sargent & Lundy's Standard Operating Procedure SOP-0405, which is based on ANSI/ISO/ASSQC Q9001 Quality Management Systems.

Contributors

Prepared by:

Name	Section(s) Prepared	Signature	Date
Henry Fidlow	Main Report and Conclusion, Attachments I to O	<i>Henry Fidlow</i>	1/26/2024
Henry Gaudin	Main Report	<i>Henry Gaudin</i>	1/26/2024
Jack Miller	Sections 4.1.2.4 and 5.1.2.4	<i>Jack Miller</i>	1/26/2024
Keith Miller	Conclusion (Thermal Cycling/Material Degradation)	<i>Keith Miller</i>	1/26/2024
Gabriel Neimark	Attachment A, Attachments C to G, Attachments P to R	<i>Gabriel Neimark</i>	1/26/2024
Nic Richards	Attachments B, H, and O	<i>Nic Richards</i>	1/26/2024

Reviewed by:

Name	Section(s) Reviewed	Signature	Date
Pawel Kut	Attachments B, H, and O	<i>Pawel Kut</i>	1/26/2024
Cherie Paugh	Sections 4.1.2.4 and 5.1.2.4	<i>Cherie Paugh</i>	1/26/2024
Jack Miller	Section 6.1.2.3	<i>Jack Miller</i>	1/26/2024
Gabriel Neimark	Attachment O	<i>Gabriel Neimark</i>	1/26/2024
Nic Richards	Main Report and Conclusion, Attachment A, Attachments C to N, Attachments P to R	<i>Nic Richards</i>	1/26/2024

Approved by:

Alan J Wilson

1/26/2024

Alan J Wilson

Date

Sr. Vice President

TABLE OF CONTENTS

1. PURPOSE	1
2. SCOPE.....	2
3. MODEL DESIGN	3
3.1. REFERENCE PLANT	3
3.1.1. PLANT DESIGN.....	3
3.1.2. AFFECTED EQUIPMENT	3
3.1.3. GENERAL ARRANGEMENT.....	4
3.2. THERMAL POWER EXTRACTION.....	4
3.3. PEPSE HEAT BALANCE MODEL	5
3.3.1. METHODOLOGY	5
3.3.2. ASSUMPTIONS	6
3.4. OPERATING EXPERIENCE.....	6
4. 30% EXTRACTION RESULTS.....	7
4.1. THERMAL ANALYSIS	7
4.1.1. PEPSE.....	7
4.1.2. PLANT IMPACTS AND CONSIDERATIONS	8
4.2. EQUIPMENT ASSESSMENT	11
4.2.1. TURBINE CYCLE	11
4.2.2. CONDENSERS	14
4.2.3. PUMPS	16
4.2.4. MOISTURE SEPARATOR REHEATERS (MSRS).....	19
4.2.5. FEEDWATER HEATERS	19
4.2.6. EXTRACTION STEAM	26
4.2.7. HEATER DRAIN SYSTEM.....	28
5. 50% EXTRACTION RESULTS.....	33
5.1. THERMAL ANALYSIS	33
5.1.1. PEPSE.....	33
5.1.2. PLANT IMPACTS AND CONSIDERATIONS	34
5.2. EQUIPMENT ASSESSMENT	35
5.2.1. TURBINE CYCLE	35
5.2.2. CONDENSERS	38

5.2.3.	PUMPS	39
5.2.4.	MOISTURE SEPARATOR REHEATERS (MSRS).....	43
5.2.5.	FEEDWATER HEATERS	43
5.2.6.	EXTRACTION STEAM	50
5.2.7.	HEATER DRAIN SYSTEM.....	52
6.	70% EXTRACTION RESULTS.....	58
6.1.	THERMAL ANALYSIS	58
6.1.1.	PEPSE.....	58
6.1.2.	PLANT IMPACTS AND CONSIDERATIONS	59
6.2.	EQUIPMENT ASSESSMENT	59
6.2.1.	FEEDWATER HEATERS.....	60
6.2.2.	EXTRACTION STEAM	66
6.2.3.	HEATER DRAIN SYSTEM.....	68
7.	CONCLUSIONS	72
7.1.	30% EXTRACTION	73
7.2.	50% EXTRACTION	74
7.3.	70% EXTRACTION	75
7.4.	SUMMARY OF IMPACTS.....	76
8.	REFERENCES.....	77
9.	ATTACHMENTS	78

FIGURES AND TABLES

FIGURE 3-1. GENERAL ARRANGEMENT FOR REFERENCE PLANT THERMAL POWER EXTRACTION	4
FIGURE 3-2. MAIN STEAM EXTRACTION	4
FIGURE 3-3. SUPPLY AND RETURN LOCATIONS	5
FIGURE 4-1. HEAT EXCHANGER DIMENSIONS (SIDE VIEW)	8
FIGURE 4-2. ENTHALPY-ENTROPY CHART (HPT)	13
FIGURE 4-3. ENTHALPY-ENTROPY CHART (LPTS)	14
FIGURE 5-1. ENTHALPY-ENTROPY CHART (HPT)	37
FIGURE 5-2. ENTHALPY-ENTROPY CHART (LPTS)	38
FIGURE 7-1. THERMAL POWER DESTINATIONS FOR THERMAL POWER EXTRACTION SCENARIOS.....	73
TABLE 3-1. PEPSE MODEL INPUT ASSUMPTIONS	6
TABLE 4-1. GENERAL IMPACTS FOR 30% THERMAL POWER EXTRACTION	7
TABLE 4-2. MASS FLOW COMPARISON	11
TABLE 4-3. CONDENSER OPERATING CONDITIONS	15
TABLE 4-4. PUMP PREFERRED OPERATING REGIONS.....	16
TABLE 4-5. EVALUATION OF PUMP DRIVER DUTY (HP)	17
TABLE 4-6. EVALUATION OF NPSH RATIO.....	17
TABLE 4-7. PUMP SUCTION AND DISCHARGE PRESSURES	18
TABLE 4-8. EVALUATION OF FWP TURBINE SPEED.....	18
TABLE 4-9. HEATER DRAIN LEVEL CONTROL VALVE EVALUATION	18
TABLE 4-10. MSR OPERATING CONDITIONS.....	19
TABLE 4-11. CONDENSATE/FEEDWATER HEATER NOZZLE VELOCITIES.....	20
TABLE 4-12. FWH TUBE VELOCITIES	21
TABLE 4-13. STEAM INLET NOZZLE VELOCITY.....	21
TABLE 4-14. DRAIN OUTLET NOZZLE VELOCITY	22
TABLE 4-15. PASS PARTITION PLATE PRESSURE LOSS	23
TABLE 4-16. HEATER DRAIN INLET NOZZLE MASS FLUX AND MASS FLUX PARAMETER.....	24
TABLE 4-17. SHELL SIDE OPERATING PRESSURES AND TEMPERATURES.....	24
TABLE 4-18. TUBE SIDE OPERATING TEMPERATURES	25
TABLE 4-19. DRAIN COOLER VIBRATION	25
TABLE 4-20. EXTRACTION STEAM LINE PRESSURE DROP	26
TABLE 4-21. EXTRACTION STEAM LINE OPERATING CONDITIONS	27
TABLE 4-22. EXPANSION JOINT LINER THICKNESS.....	28
TABLE 4-23. DRAIN VOLUMETRIC FLOW COMPARISON.....	29
TABLE 4-24. DRAIN VALVE PRESSURE LOSS.....	30
TABLE 4-25. DRAIN VALVE REQUIRED C_v CAPACITY	31
TABLE 4-26. DRAIN TANK CONDITIONS.....	32

TABLE 5-1. GENERAL IMPACTS FOR 50% THERMAL POWER EXTRACTION	33
TABLE 5-2. MASS FLOW COMPARISON	35
TABLE 5-3. CONDENSER OPERATING CONDITIONS	39
TABLE 5-4. PUMP PREFERRED OPERATING REGIONS.....	40
TABLE 5-5. EVALUATION OF PUMP DRIVER DUTY (HP).....	40
TABLE 5-6. EVALUATION OF NPSH RATIO.....	41
TABLE 5-7. PUMP SUCTION AND DISCHARGE PRESSURES	41
TABLE 5-8. EVALUATION OF FWP TURBINE SPEED.....	42
TABLE 5-9. HEATER DRAIN LEVEL CONTROL VALVE EVALUATION	42
TABLE 5-10. MSR OPERATING CONDITIONS.....	43
TABLE 5-11. CONDENSATE/FEEDWATER HEATER NOZZLE VELOCITIES.....	44
TABLE 5-12. FWH TUBE VELOCITIES	45
TABLE 5-13. STEAM INLET NOZZLE VELOCITY.....	45
TABLE 5-14. DRAIN OUTLET NOZZLE VELOCITY	46
TABLE 5-15. PASS PARTITION PLATE PRESSURE LOSS	47
TABLE 5-16. HEATER DRAIN INLET NOZZLE MASS FLUX AND MASS FLUX PARAMETER FOR 50% THERMAL POWER EXTRACTION	47
TABLE 5-17. HEATER DRAIN INLET NOZZLE MASS FLUX AND MASS FLUX PARAMETER FOR 50% THERMAL POWER EXTRACTION WITH PARTIAL LP FWH BYPASS.....	48
TABLE 5-18. SHELL SIDE OPERATING PRESSURES AND TEMPERATURES.....	48
TABLE 5-19. TUBE SIDE OPERATING TEMPERATURES	49
TABLE 5-20. DRAIN COOLER VIBRATION	49
TABLE 5-21. EXTRACTION STEAM LINE PRESSURE DROP	51
TABLE 5-22. EXTRACTION STEAM LINE OPERATING CONDITIONS	51
TABLE 5-23. EXPANSION JOINT LINER THICKNESS.....	52
TABLE 5-24. DRAIN VOLUMETRIC FLOW COMPARISON.....	53
TABLE 5-25. DRAIN VALVE PRESSURE LOSS FOR 50% THERMAL POWER EXTRACTION	54
TABLE 5-26. DRAIN VALVE REQUIRED C_v CAPACITY	55
TABLE 5-27. DRAIN TANK CONDITIONS.....	56
TABLE 6-1. GENERAL IMPACTS FOR 70% THERMAL POWER EXTRACTION	58
TABLE 6-2. CONDENSATE/FEEDWATER HEATER NOZZLE VELOCITIES.....	60
TABLE 6-3. FWH TUBE VELOCITIES	61
TABLE 6-4. STEAM INLET NOZZLE VELOCITY.....	61
TABLE 6-5. DRAIN OUTLET NOZZLE VELOCITY.....	62
TABLE 6-6. PASS PARTITION PLATE PRESSURE LOSS	63
TABLE 6-7. HEATER DRAIN INLET NOZZLE MASS FLUX AND MASS FLUX PARAMETER FOR 70% THERMAL POWER EXTRACTION	63
TABLE 6-8. SHELL SIDE OPERATING PRESSURES AND TEMPERATURES.....	64
TABLE 6-9. TUBE SIDE OPERATING TEMPERATURES	64
TABLE 6-10. DRAIN COOLER VIBRATION	65
TABLE 6-11. EXTRACTION STEAM LINE PRESSURE DROP	66

TABLE 6-12. EXTRACTION STEAM LINE OPERATING CONDITIONS	67
TABLE 6-13. EXPANSION JOINT LINER THICKNESS.....	67
TABLE 6-14. DRAIN VOLUMETRIC FLOW COMPARISON.....	68
TABLE 6-15. DRAIN VALVE PRESSURE LOSS FOR 70% THERMAL POWER EXTRACTION	69
TABLE 6-16. DRAIN VALVE REQUIRED C _v CAPACITY	70
TABLE 6-17. DRAIN TANK CONDITIONS.....	71
TABLE 7-1. GENERAL IMPACTS FOR THERMAL POWER EXTRACTION SCENARIOS.....	72

1. PURPOSE

As non-dispatchable renewables, predominantly wind and solar, continue to penetrate U.S. energy markets, the role of nuclear power generation to provide baseload power is changing. Integrating nuclear power plants with dispatchable industrial loads offers opportunities to maintain grid reliability and resiliency while allowing greater penetration of variable renewable energy. In an attempt to maximize efficiency and maintain the existing nuclear fleet, new ways to integrate energy systems are being pursued.

One of the focuses of the United States Department of Energy's (DOE) Light Water Reactor Sustainability (LWRS) program is to explore the diversification of light-water reactor (LWR) revenue streams through the Flexible Plant Operation and Generation (FPOG) Pathway. Direct steam utilization is one potential method of alternative revenue. Nuclear plant steam applications include hydrogen generation, desalination, district heating, thermal storage, and industrial processes. Steam utilization can help increase nuclear plant efficiencies and economics while providing a low-carbon solution for thermal power users.

This report assesses the impacts of high levels of thermal power extraction (TPE) on a generic nuclear plant design to determine feasible extraction limits for nuclear plant steam.

2. SCOPE

This work develops a detailed PEPSE heat balance model for a generic nuclear power plant and evaluates the impacts of 30%, 50%, and 70% thermal power extraction on the nuclear plant. Plant transients due to startup and shutdown of the thermal power extraction system will be addressed, along with impacts to the main steam bypass and final feedwater temperature. Extraction effects on plant equipment, including the high- and low-pressure turbines, main condenser, power train pumps, moisture separator reheaters, drain systems, feedwater heaters, and extraction steam are then assessed.

3. MODEL DESIGN

3.1. REFERENCE PLANT

3.1.1. Plant Design

The reference plant modeled for this report is based on 4-loop Westinghouse pressurized water reactor (PWR) design. In a PWR, high-pressure water passes through the reactor core, where it is heated by thermal energy created by nuclear fission. This primary water flows through a steam generator, where it boils feedwater in the secondary plant cycle to create steam. This steam then drives a series of turbines that rotate, generating electricity in the process. This secondary steam is separated from primary loop coolant by the steam generator, and is therefore not radioactive. As a large portion of the U.S. commercial nuclear power plant fleet were designed as Westinghouse 4-loop PWRs, this design was selected to be applicable to the greatest number of existing nuclear plants.

The reactor modeled in this report has a thermal power rating of 3650 MWt, with a plant generating capacity of approximately 1,225 MWe. Thermal power extraction (TPE) cases of 30% (~1,100 MWt), 50% (~1,825 MWt), and 70% (~2,550 MWt) are considered in this report with respect to a baseline case with no extraction. Sections 4, 5, and 6 discuss these cases in further detail.

3.1.2. Affected Equipment

This report is primarily focused on the impacts of large-volume TPE on the plant secondary cycle. Equipment is assessed to determine which specific components will require additional maintenance or replacement for 30%, 50%, and 70% TPE. The equipment assessed in Sections 4.2, 5.2, and 6.2 of this report (for the 30%, 50%, and 70% cases, respectively) includes:

- High Pressure Turbines (HPTs)
- Low Pressure Turbines (LPTs)
- Condensers
- Pumps
- Moisture Separator Reheaters (MSRs)
- Feedwater Heaters (FWHs)
- Extraction Steam
- Feedwater Heater Drains
- MSR Drains

3.1.3. General Arrangement

A generic plant arrangement, including TPE, is provided in Figure 3-1. The next section describes the method of steam extraction and thermal conversion.

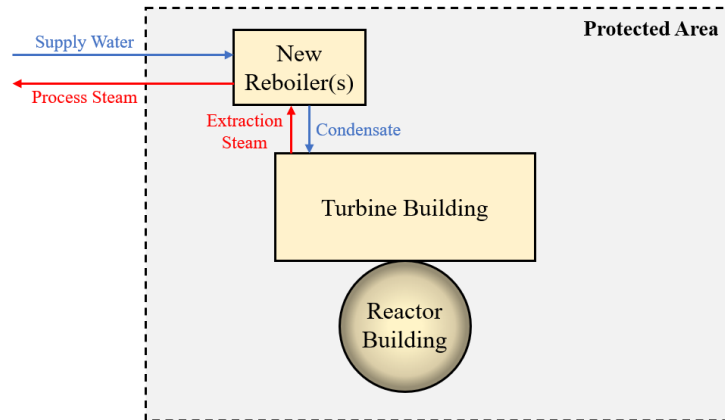

Figure 3-1. General Arrangement for Reference Plant Thermal Power Extraction

3.2. THERMAL POWER EXTRACTION

Previous work has assessed the impacts of steam extraction up to 105 MWt (~3%) on the nuclear plant [1]. At this comparatively small volume of extraction, Cold Reheat (downstream of the high-pressure turbine) was deemed optimal from a nuclear plant efficiency standpoint. However, as higher steam volumes are extracted from the Cold Reheat, turbine shaft imbalance, blade loading, and thrust may cause the turbines to deviate from intended design. Therefore, Cold Reheat steam extraction is not recommended for higher power levels and is not evaluated in this report. Additionally, high quality steam enables lower extraction volumes for the same thermal power, as well as smaller piping. As a result of these factors, the preferred location for 30%, 50%, and 70% steam extraction is Main Steam (as opposed to Cold Reheat), upstream of the high-pressure turbine.

Main Steam extraction is shown in Figure 3-2.

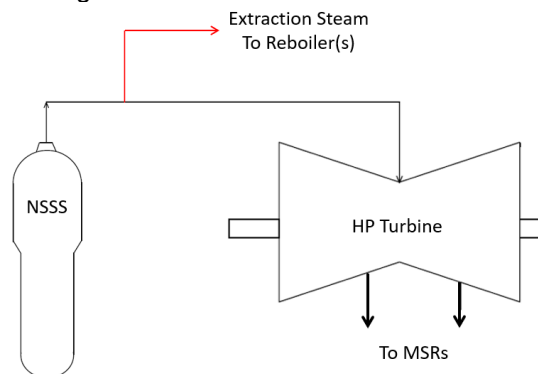

Figure 3-2. Main Steam Extraction

Following extraction, this steam would pass through a heat exchanger(s) in the Protected Area, where it would be used to heat a process fluid for the desired industrial application. The plant steam would condense in the heat exchanger before returning to the main condenser, while process steam would be piped to the desired use case.

In this work, the boiling of demineralized water is used as the reference case for modeling. However, it may be preferable to use pressurized water or a different process fluid with higher heat capacity depending on the application. Applications could include hydrogen production (via high-temperature steam electrolysis), thermal energy storage, district heating, desalination, and other industrial applications.

The supply and return locations of the process steam and nuclear steam/condensate are shown in Figure 3-3.

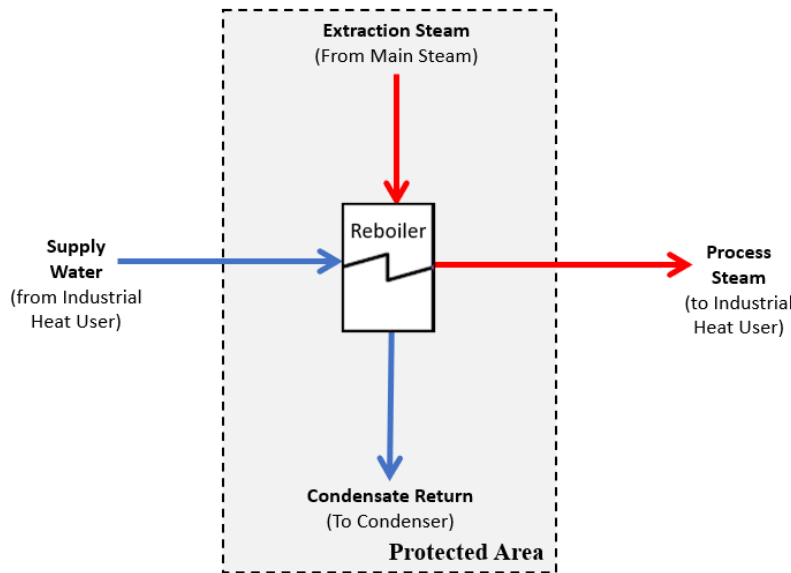

Figure 3-3. Supply and Return Locations

3.3. PEPSE HEAT BALANCE MODEL

3.3.1. Methodology

A generic PEPSE heat balance model of the reference plant is used as the starting point of this evaluation. This model is modified through the addition of splitters, mixers, and stream components to assess the impacts of 30%, 50%, and 70% TPE on the nuclear power cycle main steam system.

A heat exchanger component is used to model the steam reboiler thermal performance. The extracted steam is condensed and subcooled before it is returned to the power cycle. A pump component is used to model system pressure increase from a demineralized water supply tank to the reboiler. The amount of thermal energy extracted is calculated within PEPSE using operational variables. The amount of thermal energy extracted is controlled by changing the flow fraction out of the main steam splitter supplying the reboiler.

3.3.2. Assumptions

The PEPSE model is based on the following assumptions:

1. The temperature of the condensed and subcooled extraction steam is assumed to be 120°F before it is returned to condenser.
2. The discharge pressure for the water supply pump is assumed to be 650 psia.
3. The heat exchanger pressure drop is assumed to be 50 psid.
4. Pressure and temperature losses to the environment are included in the new associated stream components based on the assumed inputs in Table 3-1.

Table 3-1. PEPSE Model Input Assumptions

Description	Units	30% Extraction	50%/70% Extraction
Main Steam Extraction DP	psid	80	80
Main Steam Extraction Heat Loss	BTU/hr	210,000	250,000
Process Steam Extraction DP	psid	100	100
Process Steam Extraction Heat Loss	BTU/hr	2,230,000	2,700,000

* Pressure drop values used here are considered to be reasonable for this application, but will vary on a case-by-case basis, depending on pipe and equipment sizes.

3.4. OPERATING EXPERIENCE

Nuclear cogeneration is a developing field of study. Currently, there are a number of pilot projects in the United States investigating hydrogen production at existing nuclear power plants [12]. However, these projects are not extracting thermal energy at a scale significant enough to negatively impact equipment and plant operations.

The conditions most analogous to these large TPE scenarios investigated here are forced downpower or planned power reduction events. In both of these cases, plants operate below their rated power for a given period of time before returning to normal operation. On occasion, these events have lasted for weeks to months with power reductions greater than 50%, typically with no long-term plant or equipment ramifications. The Institute of Nuclear Power Operations (INPO) Industry Reporting and Information System (IRIS) database has a collection of such events, with durations ranging from minutes to weeks. The prevalence of these power reduction events provides some support for the feasibility of operation at these large TPE volumes, although equipment health needs to be monitored closely for long-term impact.

4. 30% EXTRACTION RESULTS

4.1. THERMAL ANALYSIS

4.1.1. PEPSE

The PEPSE computer program was utilized to determine the performance of the entire turbine cycle including prediction of the gross generator output. Modifying the generic PEPSE model, plant impacts were assessed for 30% TPE, as shown in Table 4-1. The PEPSE diagrams provided in Attachment A (pages A29 to A31) show the results for the baseline (0% TPE) and 30% thermal power extraction cases.

Table 4-1. General Impacts for 30% Thermal Power Extraction

Description	Units	0%	30%	Δ (30%)
Generator Electric Power	MWe	1,228.0	844.6	-31.2%
Thermal Power Extracted	MWt	0	1,095	-
% of Flow - MS	%	0	21.9	-
MS Flow from SGs	lbm/hr	16,037,390	15,436,290	-4%
HP Turbine Inlet Flow	lbm/hr	15,218,400	11,272,260	-26%
HP Turbine First Stage Pressure	psia	651.5	487.5	-25%
MSR Inlet Pressure	psia	190.3	140.2	-26%
LP Turbine Inlet Flow	lbm/hr	3,673,069	2,677,248	-27%
LP Turbine Inlet Pressure	psia	175.5	129.3	-26%
Condenser Duty	BTU/hr	8.21E+09	5.78E+09	-30%
Condensate Pump Flow	lbm/hr	11,334,490	11,723,820	3%
Heater Drain Pump Flow	lbm/hr	4,732,792	3,742,365	-21%
Feedwater Pump Flow	lbm/hr	16,067,280	15,466,190	-4%
Final Feedwater Temperature	°F	440.9	413.3	-27.6°F
Cascading Drain Flow to Condenser	lbm/hr	817,619	745,815	-9%
Reboiler Inlet Mass Flow	lbm/hr	-	3,376,114	-
Reboiler Inlet Pressure	psia	-	817.3	-
Reboiler Inlet Temperature	°F	-	520.7	-
Reboiler Inlet Enthalpy	BTU/lbm	-	1,197.2	-
Reboiler Outlet Temperature	°F	-	120.0	-
Reboiler Outlet Enthalpy	BTU/lbm	-	90.1	-

It is expected that this volume of thermal power extraction will require four (4) trains. Each train should consist of a reboiler and drain cooler (to accommodate condensate cooling and preheating of reboiler feedwater). Using a Kettle style reboiler and shell and tube drain cooler, anticipated equipment dimensions are provided below in Figure 4-1.

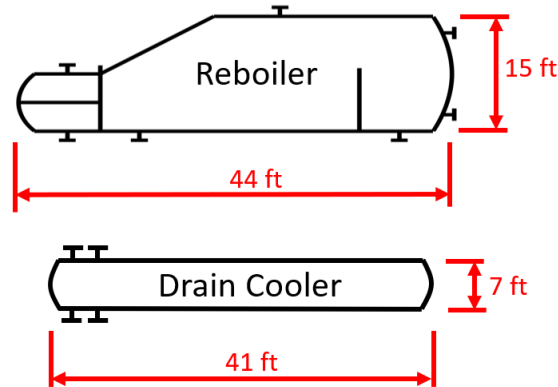

Figure 4-1. Heat Exchanger Dimensions (Side View)

Notes:

- * The reboiler is expected to be 12 ft wide.
- ** The drain cooler is expected to be 5 ft wide.

4.1.2. Plant Impacts and Considerations

4.1.2.1. Mechanical Transients

Plant operational transients must be assessed for 30% TPE. Transient events will primarily occur during startup and shutdown of the extraction system. Under 1095 MWt extraction, approximately 3,380,000 lbm/hr of steam will be sent to the reboilers from Main Steam, corresponding to approximately 22% of Main Steam flow. This extraction will reduce total Main Steam flow by 600,000 lbm/hr, or 4%.

The below sections describe the capabilities of the reactor (in response to a load rejection event) and power cycle equipment in response to a transient event, as well as changes to normal operating conditions.

4.1.2.2. Plant Hazards

Existing nuclear power plants are required to be protected from plant hazards such as high-energy line breaks (HELBs). Each station's licensing basis defines HELB criteria, which state the conditions required to define a high-energy system based on operating temperature and/or pressure limits. If a station is licensed to a temperature and pressure, both the minimum temperature and the minimum pressure criteria must be met for the system to be defined as a high-energy system. Conversely, if a station is licensed to a temperature or pressure, only one of the criteria need to be met for the system to be defined as a high-energy system. The temperature and pressure limits are defined as 200°F and 275 psig. As shown in the PEPSE heat balance diagram (Attachment A), the maximum operating conditions for 30% TPE are 532°F and 897 psia. Both of these values exceed the criteria for a high-energy system, therefore steam extraction pipe design and installation would need to be performed under a station's HELB program.

A review of a plant's specific HELB program should be conducted to assess the impact of the new high-energy lines. Some stations analyze HELBs in the Turbine Building for impact on essential equipment. Any piping additions should be routed in such a way as to be separated from any equipment that may be important to safety or station operation. Any piping additions inside the Turbine Building routing to the steam reboilers are generally expected to be smaller than the main steam line they are tied into. Therefore, the impact of a HELB in the new piping is expected to be bounded by the mass and energy release rates for existing main steam piping. Any piping routed outdoors must also be designed in accordance with the station HELB program.

4.1.2.3. Water/Steam Hammer

During the detailed design of the thermal steam extraction system, the potential for water hammer or steam hammer must be addressed. These phenomena could occur if steam or water flow rapidly stops; this condition is typically addressed by selecting appropriate valve closing times.

4.1.2.4. Core Reactivity and Plant Response

4.1.2.4.1. Overview

The impact on core reactivity associated with extracting steam from the secondary cycle must be assessed for any plant-specific modification as described within this report. Reactivity impacts are derived not only from the steam extraction, but also from the reduced feedwater temperature resulting from the supply of reboiler condensate to the main condenser. Both steam extraction and feedwater temperature variation magnitude will impact core reactivity via the core negative moderator temperature coefficient (MTC). A negative core MTC can be understood broadly to create the effect "reactor power follows steam demand". The following description of core reactivity effects does not attempt to quantify the discrete contributions of the steam extraction and feedwater temperature variation. The goal is to explain reactivity changes resulting from TPE operation and describe the expected nuclear plant control system response for extraction impacts relative to nominal plant response. The following descriptions assume that the nuclear plant is operating in Mode 1, above 15% reactor power.

Broadly speaking, TPE will impact core reactivity much in the same manner as changing the main generator electrical output. Similar to raising generator output, ramp up of TPE steam will add positive reactivity to the core through the negative MTC, resulting in a corresponding rise in reactor power. Shutdown of the TPE supply will lower the reactor power through the same effects. The sequence described below illustrates how changes to the thermal demands on the nuclear plant secondary through operation of the extraction steam supply create this effect.

4.1.2.4.2. Core Reactivity for Startup and Shutdown

In order to focus on the effects of the negative MTC, the following description purposely leaves out any discussion of plant control system response. That topic is discussed in the next section. As a result, reactor power may exceed 100% for this theoretical discussion. The following describes how steam extraction and feedwater temperature changes result in reactivity changes in the core.

On TPE startup, steam extraction from the steam generators (SGs) increases. This higher flow lowers the pressure in the SGs. As SG pressure lowers, more liquid feedwater in the SGs flashes to steam. This results in more thermal energy being extracted from the reactor coolant flowing through the SG U-tubes, thereby lowering the primary coolant temperature. This "colder" primary coolant leaves the SGs and is supplied to the core. In possessing a negative MTC, colder water results in positive reactivity being added to the core.

In addition to steam extraction, startup of the TPE system changes thermal characteristics of the nuclear plant through the lowering of feedwater temperature supplied to the SGs. As presented in Table 4-1, SG feedwater temperature lowers as extraction steam supply increases. Colder feedwater in the SG causes more thermal energy to be extracted from the primary coolant, once again delivering “colder” primary coolant to the core, adding positive reactivity, and causing a corresponding rise in reactor power. This occurs through the same negative MTC effect described in steam extraction above. Although the mechanism by which reactor coolant temperature lowers is different, the end result is the same; colder reactor coolant adds positive reactivity.

Startup, and subsequent raising of TPE volume, adds positive reactivity to the core via the negative MTC. Both the added heat removal of steam extraction and the lower SG feedwater temperature occurring during TPE system operations will lower the primary coolant returning to the core from the SGs. This positive reactivity causes more fissions in the core, thereby causing reactor power (i.e., thermal output) to rise. Increased heat production from more fissions raises the temperature of primary coolant leaving the core and being supplied to the SGs. With hotter primary coolant in the SG U-tubes, more feedwater boiling occurs and the SG pressure goes up. At this point, the effects described above are creating a new heat balance and begin to move towards achieving a new equilibrium.

After being initially lowered by added thermal output, the average primary coolant temperature rises with the increase in reactor power. The additional TPE through startup and increased output of the TPE system is now being provided through additional thermal power output of the core. As the average primary coolant temperature rises back to its previous level, reactor power will stabilize to meet the desired load.

Lowering the output and shutting down the TPE system will result in the same effects described above but in reverse, with the negative MTC now causing an overall lowering of reactor thermal output. Reduced steam extraction and the associated increase in feedwater temperature will initially cause reactor coolant temperature to rise, and therefore reactor power to lower. When in operation, changes to TPE output will drive the reactor thermal output to match the changes. As stated previously, the negative core MTC can be understood broadly to create the effect “reactor power follows steam demand”.

4.1.2.4.3. Control System Response

The previous description provides a straightforward discussion of the reactivity effects that will occur for changes in TPE. The actual integrated plant response will be determined by the magnitude and rate of change for a particular transient. It is expected that any planned TPE output changes will be controlled within the same limits as planned main generator load changes in place for the station. Using this methodology, a planned TPE load change will cause a plant control system response that behaves nearly the same as a ramp down or ramp up of total plant power output. As described previously, there may be some minor differences created due to the lower feedwater temperatures. Changes should be evaluated in core and plant response analyses and accounted for through tuning of the plant controls.

The load change limits assumed in the reference plant are established based on typical Westinghouse 4-loop PWR controls designs. These limits would allow for the plant’s Reactor Control System to act to preclude any compensatory actions beyond control rod motion. Typical Reactor Control System limits could enable the nuclear plant to accept a step load increase or decrease of 10% and a ramp increase or decrease of 5% per minute within the load range of 15% to 100% without reactor trip, steam dump, or pressurizer relief actuation, subject to possible xenon limitations.

A condition for consideration is the sudden and complete loss of the TPE steam when operating at 100% capacity (i.e., 30% reactor power). In the event of this thermal load loss, the plant controls systems would respond to the resulting thermal imbalance. The Reactor Control System would activate control rod insertion

at the maximum speed provided. This inward rod motion inserts negative reactivity to the core, reducing the number of fissions and thereby lowering reactor power. Additionally, the Steam Dump Controller would open valves that would dump steam directly to the main condenser. This would allow for continued heat removal from the core to prevent a rapid rise in primary coolant temperature and potential actuation of the pressurizer power-operated relief valves. The reference plant Reactor Control System is assumed to have the capacity to compensate for a 10% step change. Additionally, the Steam Dumps are assumed to compensate for up to 40% step change. Between the two responses, a complete loss of the 30% TPE is well within plant control system response capacity.

4.2. EQUIPMENT ASSESSMENT

The effects of 30% TPE on plant secondary equipment has been investigated. A detailed description of the effects on this equipment can be found in Attachments B through H.

4.2.1. Turbine Cycle

A representative turbine cycle was chosen to evaluate the impacts of TPE on turbine performance and operations. A single HPT and three parallel LPTs were modeled. The representative cycle contained a MSR between the HPT and LPTs, where moisture is removed from the HPT exhaust and heated with two stages of regenerative heating. The turbines provide extraction to seven FWH stages.

The representative turbine cycle performance was modeled in a PEPSE model which contains cases benchmarked to the turbine vendor's thermal kit. Cases at Valves Wide Open (VWO), rated thermal power (100%), and 75% power are provided.

For the case with 30% turbine cycle thermal energy extracted, the PEPSE heat balance was modified as documented in Attachment A. The modification included removal of steam from the main steam system and return of the condensate to the main condenser after energy was extracted in the reboiler/s.

Table 4-2 shows the change in mass flows at various location along the turbines.

Table 4-2. Mass Flow Comparison

Location	Mass Flow Rate (lbm/hr)		Δ (30%)
	0%	30%	
Throttle Valve Inlet	15,218,400	11,272,260	-26%
HPT Bowl (Left)	7,609,201	5,636,129	-26%
Governing Stage Shell (Left)	7,609,201	5,636,129	-26%
FWH6 Extraction Stage (Left)	6,808,507	4,939,882	-27%
HPT Exhaust (Left)	6,808,507	4,939,882	-27%
HPT Bowl (Right)	7,609,201	5,636,129	-26%
Governing Stage Shell (Right)	7,609,201	5,636,129	-26%

Location	Mass Flow Rate (lbm/hr)		Δ (30%)
	0%	30%	
FWH7 + RH2 Extraction Stage (Right)	6,550,264	4,879,028	-26%
HPT Exhaust (Right)	6,550,264	4,879,028	-26%
LPT A Bowl	3,673,069	2,677,248	-27%
FWH4A Extraction Stage	3,470,241	2,479,494	-29%
FWH3A Extraction Stage	3,271,723	2,285,586	-30%
FWH2A Extraction Stage	3,075,061	2,108,017	-31%
MR (to FWH1A) Extraction Stage	3,015,812	2,069,513	-31%
FWH1A Extraction Stage	2,855,450	1,931,433	-32%
MR (to LPT A Exhaust) Extraction Stage	2,788,284	1,889,616	-32%
LPT A Exhaust	2,788,284	1,889,616	-32%
LPT B Bowl	3,673,069	2,677,248	-27%
FWH4B Extraction Stage	3,468,763	2,478,139	-29%
FWH3B Extraction Stage	3,273,638	2,287,097	-30%
FWH2B Extraction Stage	3,068,421	2,102,369	-31%
MR (to FWH1B) Extraction Stage	3,008,809	2,064,802	-31%
FWH1B Extraction Stage	2,847,364	1,924,897	-32%
MR (to LPT B Exhaust) Extraction Stage	2,780,228	1,882,541	-32%
LPT B Exhaust	2,780,228	1,882,541	-32%
LPT C Bowl	3,673,069	2,677,249	-27%
FWH4C Extraction Stage	3,473,448	2,482,813	-29%
FWH3C Extraction Stage	3,278,225	2,291,586	-30%
FWH2C Extraction Stage	3,070,612	2,103,231	-32%
MR (to FWH1C) Extraction Stage	3,011,389	2,064,763	-31%
FWH1C Extraction Stage	2,850,762	1,926,528	-32%
MR (to LPT C Exhaust) Extraction Stage	2,783,458	1,884,387	-32%
LPT C Exhaust	2,783,458	1,884,387	-32%

4.2.1.1. High-Pressure Turbine

As shown in Table 4-1, the main turbine is expected to experience a reduction in mass flow rate of at least 25% when operating in the 30% TPE case. HPT flows are expected to reduce by a similar amount on either side of the HPT flow path. Therefore, additional stress due to turbine imbalance is not expected.

HPT performance modeled by PEPSE is visually represented on the Enthalpy-Entropy Chart in Figure 4-2.

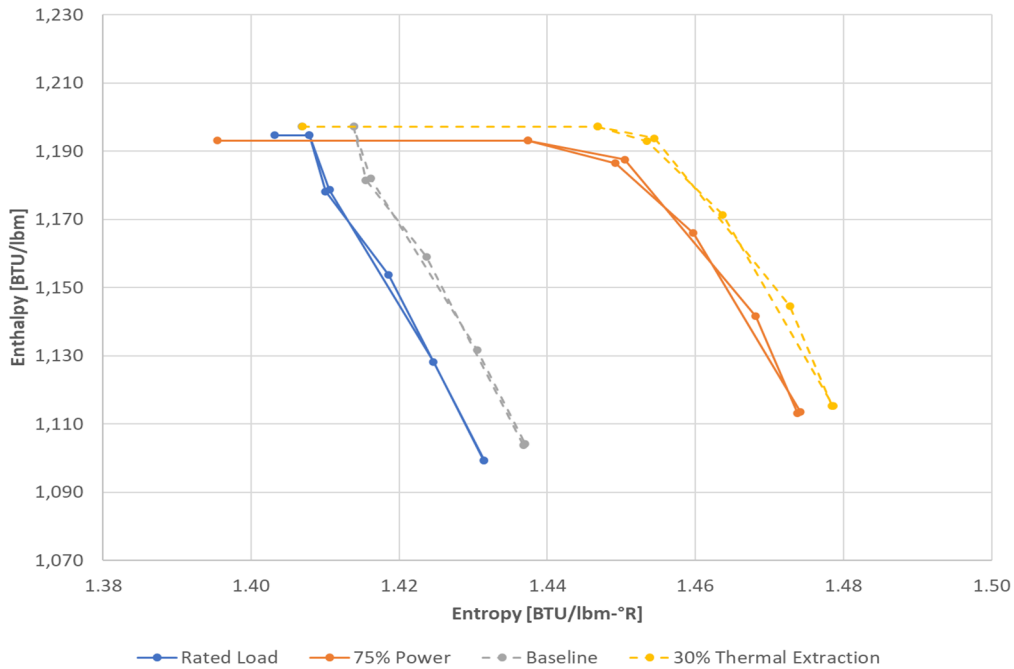

* Rated load and 75% power cases refer to the turbine kit values from the vendor for the specific turbine design. Baseline refers to normal operation with 0% TPE.

Figure 4-2. Enthalpy-Entropy Chart (HPT)

As shown in the entropy-enthalpy chart, the 30% TPE case trends very closely with the 75% power case. Based on the review of PEPSE heat balance conditions, the turbine is expected to operate within design for the 30% TPE case. However, final acceptability of operation under this condition must be confirmed with the turbine original equipment manufacturer (OEM) on a plant specific basis.

Complete HPT analysis is included as Attachment B.

4.2.1.2. Low-Pressure Turbines

As shown in Table 4-1, the LPTs experience a mass flow rate reduction of at least 25% when operating in the 30% TPE case.

The entropy-enthalpy chart for the LPTs is shown below in Figure 4-3.

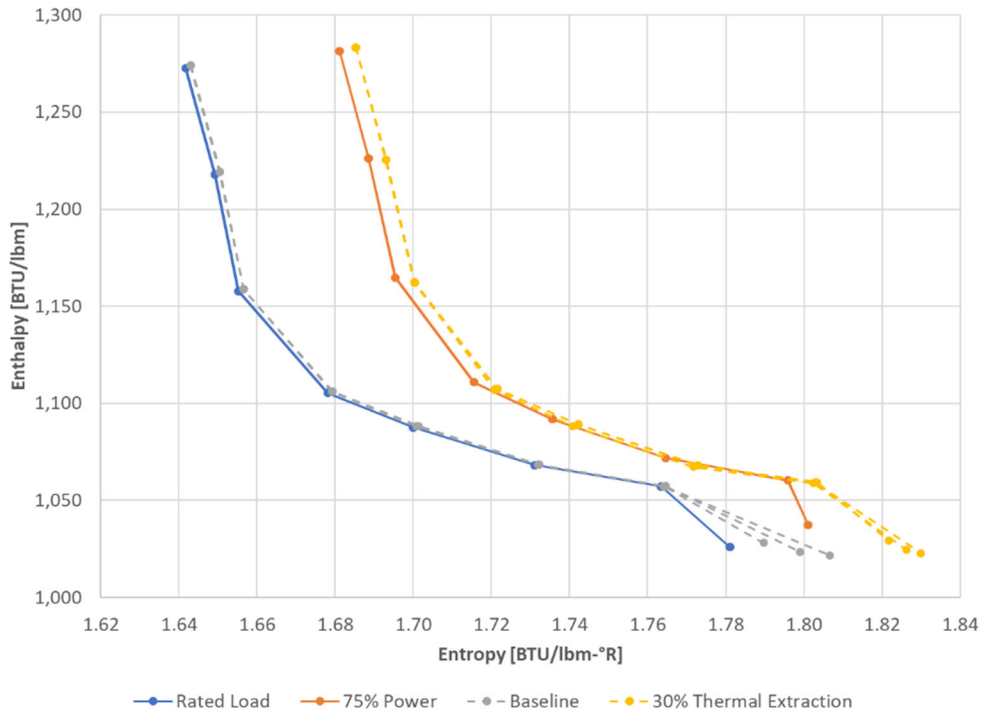

* Rated load and 75% power cases refer to the turbine kit values from the vendor for the specific turbine design. Baseline refers to normal operation with 0% TPE.

Figure 4-3. Enthalpy-Entropy Chart (LPTs)

As in the HPT Enthalpy-Entropy Chart, the 30% TPE case trends very closely with the 75% power case. Based on the review of the PEPSE heat balance conditions, the turbines are expected to operate within design for up to 30% TPE. Final acceptability of operation under this condition must be confirmed with the turbine OEM on a plant specific basis.

Complete analysis of the LPTs is included as Attachment B.

4.2.2. Condensers

The main condenser is the steam cycle heat sink. During normal operation it receives and condenses LP turbine exhaust steam and turbine bypass steam. The main condenser is also a collection point for other steam cycle miscellaneous flows, drains, and vents.

Although there are three independent zones for steam flow, the condenser has a single pass of Circulating Water (CW). CW enters at the low-pressure zone, passes through the intermediate-pressure zone, and exits at the high-pressure zone. The cold surface of the stainless steel tubes condense the steam into water, which is collected in the hotwell.

The operating conditions of the main condenser were evaluated for the 30% TPE scenario with respect to baseline (0% TPE) operation. Required air removal capacity was not specifically evaluated as, during operation, the major sources of noncondensable gases are not expected to change compared to baseline conditions.

Condenser operating conditions are tabulated below in Table 4-3.

Table 4-3. Condenser Operating Conditions

Description	Units	0%	30%	Δ (30%)
Condenser A Shell Pressure	psia	1.24	1.01	-18.9%
Condenser A Shell Flow	lbm/hr	3,120,435	2,198,666	-29.5%
Condenser A Duty	BTU/hr	2.92E+09	2.11E+09	-27.8%
Condenser B Shell Pressure	psia	1.38	1.07	-22.5%
Condenser B Shell Flow	lbm/hr	2850639	1,928,182	-32.4%
Condenser B Duty	BTU/hr	2.64E+09	1.83E+09	-30.7%
Condenser C Shell Pressure	psia	1.64	1.22	-25.9%
Condenser C Shell Flow	lbm/hr	2,854,037	1,929,813	-32.4%
Condenser C Duty	BTU/hr	2.65E+09	1.85E+09	-30.4%
Hotwell Temperature	°F	115.6	105.1	-10.5°F
Condensate Flow	lbm/hr	11,334,490	11,723,820	3.43%

The evaluation of condenser operating conditions shows that the condenser will continue to meet operation requirements for 30% TPE conditions, and the evacuation capacity of the condensers is not affected by operating with 30% TPE conditions. Condenser steam flow rates, backpressures, and heat loads decrease for the TPE case; therefore, backpressure limits will not be challenged and flow-induced vibrations will be reduced. Overall condenser duty decreases for 30% TPE since diverting large amount of main steam from the turbine cycle and condensing it elsewhere results in less heat removal in condenser given the same amount of circulating water.

A detailed analysis of the condenser can be found as Attachment C.

4.2.3. Pumps

The power conversion system is a closed cycle, with the condensate (CD), condensate booster (CB), and feedwater (FW) systems working to deliver water from the condenser hotwell to the four SGs. The Condensate Pumps (CDPs) draw water from the condenser and pump it through the Steam Jet Air Ejector (SJAE) Condensers and Gland Steam Condensers (GSCs) to the Condensate Booster Pumps (CBPs). The booster pumps provide the required head to pump condensate through the Low Pressure (LP) FWs and to provide sufficient suction head at the two Turbine Driven Feed Pumps (TDFPs). The water collected from the heater drains is stored in the Heater Drain Tank (HDT) and is forwarded into the CB system upstream of the 5th point heaters through the Heater Drain Pumps (HDPs). In the FW system, the water is pumped through one stage of High Pressure (HP) FWs and then on to four SGs.

The power train pump systems evaluated under 30% TPE are the CDPs, CBPs, FWPs, and the HDPs, along with the associated HDT control valves. Each system was analyzed through the use of a generic Fathom hydraulic model of the CD, CB, HD forwarding, and FW systems. The condenser pressure, FW flow, HD flow, and water temperatures were taken from the PEPSE Heat Balance results. These conditions are shown in Attachment D.

4.2.3.1. Preferred Operating Region (POR)

Table 4-4 shows the preferred operating region (POR) for the four pumps evaluated. For the CDPs, CBPs, and TDFPs, the percent best efficiency point (BEP) remains within the associated POR, and changes from the base scenario to the 30% TPE case are minimal. The HDPs experience a significant change in operating point and will have to be evaluated on a plant-specific basis. However, it is not expected that any equipment changes will be required.

Table 4-4. Pump Preferred Operating Regions

Pump	Acceptance Criteria	0%	30%	Δ (30%)
Condensate Pumps (CDP)	70% - 120%	109.6	113.0	3.1%
Condensate Booster Pumps (CBP)	70% - 120%	114.3	117.8	3.1%
Turbine Drain Feed Pump (TDFP)	70% - 120%	99.1	95.2	-3.9%
Heater Drain Pumps (HDP)	80% - 115%	102.8	79.9	-22.3%

4.2.3.2. Pump Driver Duty

The power requirement for each pump to perform as hydraulically characterized in the Fathom model is reported as part of the pump performance results. The evaluation of these pump drivers under the baseline (0% TPE) and 30% TPE scenarios is tabulated in Table 4-5 below.

Table 4-5. Evaluation of Pump Driver Duty (hp)

Pump	Horsepower (hp)		Δ (30%)
	0%	30%	
CDP Gearbox	664	680	2.3%
CDP/CBP Motor	3157	3224	2.1%
TDFP Turbine	8590	8170	-4.9%
HDP Motor	1894	1877	-0.9%

The duty on the CDP gearbox and CDP/CBP motor increases slightly for the 30% TPE case. These will need to be evaluated against the rated horsepower of their associated drivers. The duty on the TDFP turbine and HDP motor decreases and is expected to meet the acceptance criteria for the 30% TPE case.

4.2.3.3. Net Positive Suction Head (NPSH) Ratio

The NPSH ratio (NPSHa/NPSHr) is a measure of the available suction head margin for a pump. Vertical pumps often operate without NPSH margin, and only require that the net positive suction head available (NPSHa) exceed the net positive suction head required (NPSHr). Though vertical pumps require an NPSH ratio of 1, a general acceptance criterion of 2.0 to 2.5 is used for conservatism, depending on the pump.

Table 4-6 provides the NPSH ratio for the evaluated pumps.

Table 4-6. Evaluation of NPSH Ratio

Pump	HI / ANSI Guideline	0%	30%	Δ (30%)
CDP	≥ 2.0	1.86	1.76	-5.5%
CBP	≥ 2.5	2.86	2.39	-16.5%
TDFP	≥ 2.5	2.42	3.55	46.7%
HDP	≥ 2.0	16.27	16.13	-0.9%

The NPSH ratio for the TDFPs significantly improves, and while the NPSH ratio decreases for the HDPs, this change is small. The CDP NPSH ratio is below the HI/ANSI guideline for both cases, but it is not expected that TPE will significantly increase the risk of cavitation since the change from the baseline scenario is relatively small (~5.5%). The NPSH ratio for CBPs decreases more significantly (over 16%) and it falls below the guideline for the 30% TPE case. Therefore, although no physical changes are expected to the CDPs, CBPs, and HDPs, they should be evaluated for acceptance on a plant-specific basis for the 30% TPE case.

4.2.3.4. Suction and Discharge Pressure

Suction and discharges pressures for each pump are compared in Table 4-7 below. This evaluation is used to see which pumps may be at risk of falling below alarm setpoints.

Table 4-7. Pump Suction and Discharge Pressures

Pump	Suction Pressure (psig)			Discharge Pressure (psig)		
	0%	30%	Δ (30%)	0%	30%	Δ (30%)
CDP	-5.1	-5.5	-3.9%	129.5	127.1	-1.6%
CBP	99.2	94.9	-3.8%	584.3	570.3	-2.3%
TDFP	425.0	412.3	-2.9%	1130.5	1122.1	-0.7%
HDP	184.8	136.5	-24.2%	696.1	763.6	9.5%

Overall, suction and discharge pressures decrease for the 30% TPE case. Suction pressures will need to be evaluated on a plant-specific basis to ensure that they do not fall below low alarm setpoints. Alarm setpoints may need to be adjusted based on the conclusions of the plant-specific evaluation.

4.2.3.5. Turbine Driven Feedwater Pump Speed

The FW pump flow is regulated by the speed of the driving turbine, which receives steam from the main steam system. The Fathom model calculated turbine speed based on the required flow and TDFP developed head.

Table 4-8. Evaluation of FWP Turbine Speed

Description	Speed (rpm)		Δ (30%)
	0%	30%	
Max Calculated Turbine Speed	5,022	4,934	-1.8%

As shown in Table 4-8 above, the max calculated turbine speed decreases, therefore the margin improves for the 30% TPE case and is not expected to challenge the acceptance criteria for TDFP speed.

4.2.3.6. Heater Drain Tank Level Control Valves

The heater drain tank level control valves were evaluated for controlling margin. Acceptable control margin corresponds to a valve position of less than 50% open, so that each operating valve maintains the ability to pass all of the drain flow.

Table 4-9. Heater Drain Level Control Valve Evaluation

Description	Acceptance Criteria	Valve Position (% Open)		Δ (30%)
		0%	30%	
HD Level Control Valve	≤ 50%	26.0	16.9	-35.1%

Based on these results in Table 4-9, the HD tank level control valves meet the acceptance criteria, improving margin for the 30% TPE case.

4.2.3.7. Power Train Pump Assessment Summary

Based on the analysis above, the changes from baseline (0% TPE) operation to 30% TPE on power train pumps are minimal. It is not expected that there will be any equipment changes necessary. However, pumps should be evaluated on a plant-specific basis to ensure all acceptance criteria are met.

A detailed pump analysis is provided in Attachment D.

4.2.4. Moisture Separator Reheaters (MSRs)

The MSRs take wet exhaust steam from the HPT and pass it through a series of chevrons to remove moisture. The steam then goes through two stages of heat exchangers where it is heated before being sent to the LPTs.

MSR operating conditions for the baseline (0% TPE) and 30% TPE scenarios are compared in Table 4-10.

Table 4-10. MSR Operating Conditions

Description	Units	0%	30%	Δ (30%)
MSR Removal Effectiveness	-	0.95	0.95	0.00%
MSR Chevrons Inlet Flow	lbm/hr	3,151,396	2,266,680	-28.1%
MSR Chevrons Inlet Enthalpy	BTU/lbm	1,104	1,115	1.02%
MSR Chevrons Inlet Pressure	psia	190.3	140.2	-26.3%
MSR 1st Stage Inlet Enthalpy	BTU/lbm	1,193	1,189	-0.31%
MSR 1st Stage Inlet Pressure	psia	184.6	136.0	-26.3%
MSR 2nd Stage Inlet Enthalpy	BTU/lbm	1,227	1,222	-0.41%
MSR 2nd Stage Inlet Pressure	psia	181.8	134.0	-26.3%

The impacts to the MSRs are primarily a reduction in flow, with minimal change in enthalpies. The approximately 28% mass flow reduction is similar to 75% power with no TPE. From these results, it is concluded that MSRs will not be affected by 30% TPE operating conditions.

For a detailed analysis of the MSR, refer to Attachment E.

4.2.5. Feedwater Heaters

The Condensate (CD) and Feedwater (FW) systems deliver feedwater (condensed steam) to the steam generators. The CD system first directs flow through three parallel strings of low-pressure feedwater heaters (1st point external drain cooler and 1st through 4th point heaters). Flow then passes through two parallel strings of low-pressure feedwater heaters (5th point external drain cooler, 5th and 6th point heaters) to the TDFPs. FW flow then continues through two parallel high pressure feedwater heaters (7th point heaters) to the steam

generators. The feedwater heaters receive extraction steam flow and moisture separator reheater drain flow from the turbine system. Relevant values from the FWH evaluation are provided below.

4.2.5.1. Nozzle and Tube Velocities

Table 4-11 provides the feedwater heater channel end nozzle velocities under baseline (0% TPE) and 30% TPE scenarios.

Table 4-11. Condensate/Feedwater Heater Nozzle Velocities

FW Heater	Velocity (ft/s)			Δ (30%)
	HEI Limit	0%	30%	
1st EDC	10	11.9	12.3	3.4%
1st Point	10	11.9	12.3	3.4%
2nd Point	10	11.9	12.3	3.4%
3rd Point	10	11.9	12.3	3.4%
4th Point	10	11.9	12.3	3.4%
5th EDC	10	10.0	10.3	3.4%
5th Point	10	9.6	9.2	-3.7%
6th Point	10	9.6	9.2	-3.7%
7th Point Inlet	10	10.2	9.8	-3.7%
7th Point Outlet	10	15.8	15.2	-3.7%

Tube side nozzle velocities exceed the Heat Exchange Institute (HEI) guidelines for several of the FWHs; however, changes from the baseline case are small. As a result, feedwater nozzle wear is not expected to be an issue.

Table 4-12 provides the FWH tube velocities based on the density at average tube temperature.

Table 4-12. FWH Tube Velocities

FW Heater	Velocity (ft/s)			Δ (30%)
	HEI Limit	0%	30%	
1 st EDC	10	10.7	11.0	3.1%
1 st Point	10	8.9	9.2	3.0%
2 nd Point	10	9.1	9.3	2.7%
3 rd Point	10	9.6	9.9	2.5%
4 th Point	10	8.1	8.2	2.2%
5 th EDC	10	7.0	7.1	2.0%
5 th Point	10	9.1	8.6	-5.2%
6 th Point	10	8.5	8.0	-5.4%
7 th Point	10	8.8	8.3	-5.8%

Tube velocities remain below or marginally exceed the HEI guidelines for the 30% TPE case. Because changes are small, it is not expected that this will impact FWH tube degradation.

Table 4-13 and Table 4-14 provide the FWH steam inlet and drain outlet nozzle velocities, respectively.

Table 4-13. Steam Inlet Nozzle Velocity

FW Heater	Velocity (ft/s)			Δ (30%)
	HEI Limit	0%	30%	
1 st Point	215	137	181	32.6%
2 nd Point	195	148	206	38.9%
3 rd Point	179	179	249	39.1%
4 th Point	167	156	214	37.5%
5 th Point	156	101	115	37.2%
6 th Point	150	103	139	19.8%
7 th Point	146	80	123	5.39%

Table 4-14. Drain Outlet Nozzle Velocity

FW Heater	Velocity (ft/s)			Δ (30%)
	HEI Limit	0%	30%	
1st EDC	4.0	2.3	2.1	-9.13%
1st Point	4.0	1.8	1.5	-20.2%
2nd Point	4.0	2.9	2.7	-5.49%
3rd Point	4.0	2.4	2.3	-3.27%
4th Point	4.0	2.8	2.7	-3.63%
5th EDC	4.0	1.8	1.5	-14.1%
5th Point	4.0	2.5	2.1	-14.3%
6th Point	4.0	2.7	2.3	-13.7%
7th Point	4.0	2.2	1.9	-13.6%

Steam inlet nozzle velocities for the TPE case increase for all FWHs and exceed the HEI guideline for the 2nd, 3rd and 4th point heaters. Shell wear rates will likely slightly increase and should be considered during regular future inspections. Based on the past experience with the power uprate projects which similarly increased flow velocities, no FWH replacement is expected unless the existing FWH are already in poor condition.

Drain outlet velocities decrease for the TPE case, therefore HEI guidelines are not challenged, and wear rates may decrease.

4.2.5.2. Tube Side Pressure Drop

The tube side pressure drop principally affects two design issues, (i) the differential pressure across the pass partition plate (PPP), and (ii) the total pressure drop in the feedwater train.

To review the impact on PPP pressure loss, the change in mass flow rate squared is shown in Table 4-15.

Table 4-15. Pass Partition Plate Pressure Loss

FW Heater	Mass Flow Rate (lbm/hr)		Ratio of Flow Rates, R (30% / 0%)		PPP dP
	0%	30%	R	R ²	
1st EDC	3,778,163	3,907,940	103%	107%	7.0%
1st Point	3,778,163	3,907,940	103%	107%	7.0%
2nd Point	3,778,163	3,907,940	103%	107%	7.0%
3rd Point	3,778,163	3,907,940	103%	107%	7.0%
4th Point	3,778,163	3,907,940	103%	107%	7.0%
5th EDC	5,667,245	5,861,910	103%	107%	7.0%
5th Point	8,033,640	7,733,095	96%	93%	-7.3%
6th Point	8,033,640	7,733,095	96%	93%	-7.3%
7th Point	8,033,640	7,733,095	96%	93%	-7.3%

The pressure loss across the PPP is expected to increase in FWHs 1 through 4 and both external drain coolers. However, the expected increase in tube side pressure drop for the TPE case is not expected to appreciably impact reliable operation of the heaters.

4.2.5.3. Drain Inlet Nozzle Mass Flux

The mass flux and mass flux parameter of flashing condensate flows entering the shell side of the FWHs are provided in Table 4-16.

Drain inlet mass fluxes remain below HEI guidelines. However, the FWH 7 inlet mass flux parameter increases by nearly 50%; therefore, if the subject station does not show sufficient margin to allow for this increase, the drain inlets could see the additional flashing steam causing increased wear which should be considered during future inspections.

Table 4-16. Heater Drain Inlet Nozzle Mass Flux and Mass Flux Parameter

FW Heater	Mass Flux (lbm/s/ft ²)				Mass Flux Parameter (lbm/ft/s ²)			
	HEI Limit	0%	30%	Δ (30%)	HEI Limit	0%	30%	Δ (30%)
1 st EDC	250	141	129	-8.9%	4,000	4,755	4,110	-13.6%
2 nd Point	250	148	144	-2.4%	4,000	6,491	7,214	11.1%
3 rd Point	250	179	174	-2.5%	4,000	4,141	4,741	14.5%
5 th EDC	250	102	89	-12.9%	4,000	199	150	-25.4%
5 th Point (cascading)	250	188	165	-12.2%	4,000	647	490	-24.3%
5 th Point (MSR)	250	119	79	-33.2%	4,000	4409	2,414	-45.2%
6 th Point	250	118	104	-11.7%	4,000	515	404	-21.7%
7 th Point	250	112	107	-3.9%	4,000	2,177	3,231	48.4%

4.2.5.4. Operating Pressure and Temperature

Shell side operating pressure and temperature is provided in Table 4-17. Tube side operating temperature is provided in Table 4-18.

Table 4-17. Shell Side Operating Pressures and Temperatures

FW Heater	Pressure (psia)			Temperature (°F)		
	0%	30%	Δ (30%)	0%	30%	Δ (30%)
1 st EDC	5.4	3.6	-33.4%	165.6	149.0	-16.6°F
1 st Point	5.4	3.6	-33.0%	165.6	149.0	-16.6°F
2 nd Point	15.9	10.8	-32.0%	215.9	196.8	-19.1°F
3 rd Point	40.6	28.2	-30.6%	268.1	246.7	-21.4°F
4 th Point	89.5	64.5	-28.0%	319.9	297.4	-22.4°F
5 th EDC	186.1	137.1	-26.3%	375.8	351.4	-24.4°F
5 th Point	186.1	137.1	-26.3%	375.8	351.4	-24.4°F
6 th Point	287.1	212.7	-25.9%	413.3	387.0	-26.3°F
7 th Point	408.7	303.0	-25.9%	446.7	418.3	-28.4°F

Table 4-18. Tube Side Operating Temperatures

FW Heater	Temperature (°F)		Δ (30%)
	0%	30%	
1 st EDC	126.6	113.5	-13.1°F
1 st Point	161.7	144.8	-16.9°F
2 nd Point	212.8	192.6	-20.2°F
3 rd Point	265.0	243.3	-21.7°F
4 th Point	316.4	293.5	-22.9°F
5 th EDC	332.2	306.8	-25.4°F
5 th Point	370.2	345.9	-24.3°F
6 th Point	409.7	383.7	-25.9°F
7 th Point	441.5	413.8	-27.7°F

Operating temperatures and pressures decrease for all FWHe, therefore margins with design values will improve for the TPE case.

4.2.5.5. Drain Cooler Tube Vibration

Tube vibration in the 1st through 7th point heater drain coolers is evaluated by comparing the drain cooler volumetric flow rates. Results are provided in Table 4-19 below.

Table 4-19. Drain Cooler Vibration

FW Heater	Drain Volumetric Flow Rate (gpm)		Δ (30%)
	0%	30%	
1 st EDC	1,671	1,518	-9.1%
2 nd Point	1,240	1,172	-5.5%
3 rd Point	842	814	-3.3%
4 th Point	439	423	-3.6%
5 th EDC	3,767	3,235	-14.1%
6 th Point	2,434	2,100	-13.7%
7 th Point	1,578	1,363	-13.6%

The volumetric flow through all drain coolers is expected to decrease during operation, resulting in increased margin for tube vibration parameters.

4.2.5.6. Feedwater Heater Assessment Summary

Tube and tube side nozzle velocities exceed the HEI guidelines for several of the FWHs, but changes from the baseline case are small or decrease, therefore it is not expected that FWH tube degradation or nozzle wear will be an issue. Steam inlet nozzle velocities exceed HEI guidelines for the 2nd, 3rd, and 4th point heaters. This could affect wear patterns of the shells, which should be noted during future inspection. Tube side pressure drop for the TPE case is not expected to appreciably impact reliable operation of the heaters. Drain inlet mass fluxes remain below HEI guidelines, but the mass flux parameters for various heaters exceed the guidelines for the TPE case. For most FWHs, however, the mass flux parameter decreases or exhibits small increases. Operating temperatures and pressures decrease for all FWHs; therefore, design margins will improve for the TPE case. Volumetric flow through all drain coolers is also expected to decrease during TPE operation, resulting in increased margin for tube vibration parameters.

It is not anticipated that feedwater heaters replacement will be required for 30% TPE. However, normal plant inspections would remain suitable to identify potential flow accelerated corrosion issues. This conclusion is supplemented by past experience with power uprates which similarly increased flow velocities in these and many other FWH locations. In most instances, no FWH replacements were required if the condition of the existing FWHs was satisfactory.

A detailed evaluation of the feedwater heaters is provided in Attachment F.

4.2.6. Extraction Steam

To maximize steam cycle efficiency, the Extraction Steam (ES) system diverts steam taken from the turbine to the feedwater heaters. There are three stages of extraction from the HPT and four stages of extraction from each LPT. The Extraction Steam is used to heat the feedwater in seven separate feedwater heater stages.

There are three trains for the 1st through 4th point LP feedwater heaters, two trains for the 5th and 6th point LP feedwater heaters, and two trains for the 7th point HP feedwater heater.

Heat balance data for the baseline (0% TPE) and 30% TPE scenarios is discussed below.

4.2.6.1. Pressure Drop

Table 4-20 shows the pressure drop in the ES lines.

Table 4-20. Extraction Steam Line Pressure Drop

Description	Upstream Pressure (psia)			Pressure Drop (psid)		
	0%	30%	Δ (30%)	0%	30%	Δ (30%)
HPT to 7th Stg FWH	451.0	337.0	-25.3%	6.50	5.24	-19.4%
HPT to 6th Stg FWH	296.5	219.7	-25.9%	8.46	8.82	4.2%
HPT to 5th Stg FWH	190.3	140.2	-26.3%	4.97	6.82	37.4%
LPT to 4th Stg FWH	92.39	66.6	-27.9%	4.33	5.80	33.9%

Description	Upstream Pressure (psia)			Pressure Drop (psid)		
	0%	30%	Δ (30%)	0%	30%	Δ (30%)
LPT to 3rd Stg FWH	41.9	29.11	-30.5%	3.24	4.41	35.8%
LPT to 2nd Stg FWH	16.43	11.18	-32.0%	0.78	0.98	25.9%
LPT to 1st Stg FWH	5.428	3.637	-33.0%	0.13	0.14	6.4%

The pressure drop in the lines from the HPT to 7th stage FWHs decreases, but all other extraction steam lines see an increase in pressure drop for the extraction case, with the most significant changes in lines to the 2nd, 3rd, 4th, and 5th stage FWHs.

4.2.6.2. Operating Conditions

ES line pressures and temperatures are compared below in Table 4-21.

Table 4-21. Extraction Steam Line Operating Conditions

Description	Line Pressure (psia)			Line Temperature (°F)		
	0%	30%	Δ (30%)	0%	30%	Δ (30%)
HPT to 1st Stg Rhtr	448.7	335.3	-25.3%	456.50	428.15	-28.4°F
HPT to 7th Stg FWH	408.7	303.0	-25.9%	456.50	428.15	-28.4°F
HPT to 6th Stg FWH	287.1	212.7	-25.9%	416.29	389.77	-26.5°F
HPT to 5th Stg FWH	186.1	137.1	-26.3%	377.64	353.15	-24.5°F
LPT to 4th Stg FWH	89.6	64.6	-27.9%	382.52	386.44	3.9°F
LPT to 3rd Stg FWH	40.6	28.2	-30.5%	270.06	248.61	-21.4°F
LPT to 2nd Stg FWH	15.9	10.8	-32.0%	217.68	198.51	-19.2°F
LPT to 1st Stg FWH	5.4	3.6	-33.0%	165.73	149.10	-16.6°F

Pressures and temperatures decrease for the TPE case in all lines other than a small temperature increase in the 4th Stg FWH line. Based on these results, margins for design pressures and temperatures will largely improve for relevant valves and expansion joints.

4.2.6.3. Expansion Joint Liner Thickness

Required liner thicknesses are compared in Table 4-22.

Table 4-22. Expansion Joint Liner Thickness

Description	Required Liner Thickness (in)		Δ (30%)
	0%	30%	
LPT to 4th Stg FWH	0.137	0.160	17.2%
LPT to 3rd Stg FWH	0.138	0.163	17.9%
LPT to 2nd Stg FWH	0.156	0.184	17.8%
LPT to 1st Stg FWH	0.149	0.172	15.1%

Liner thickness requirements increase for the TPE case. Existing expansion joints will need to be evaluated on a plant-specific basis and may need to be replaced to ensure they meet these requirements.

4.2.6.4. Extraction Steam Assessment Summary

Analysis of the extraction steam system for the 30% TPE scenario shows that overall, extraction steam line pressure drops increase due to higher flow velocities. The increased flow velocities should be included in the individual station Flow Accelerated Corrosion (FAC) program to ensure that any potential degradation is properly monitored and addressed.

Expansion joint liner thickness requirements also increase, and existing expansion joints will need to be evaluated on a plant-specific basis. Replacement may be needed to ensure expansion joint requirements are met. Pressures and temperatures mostly decrease during operation with TPE, therefore operating condition design margins will largely improve for valves and expansion joints in the extraction steam system.

Refer to Attachment G for a detailed evaluation of the Extraction Steam system.

4.2.7. Heater Drain System

There are seven stages of feedwater heating for normal operations. Two parallel trains ('A' and 'B' trains), each consisting of FWH 5, 6 and 7 are available for normal operation. Drains cascade back to the heater drain tank starting at FWH 7. Flow for each train passes through the FWH 5 external drain coolers before entering the HDT. Emergency drains to the condenser are available for FWHs 5, 6, and 7.

Three parallel FWH drain trains ('A' train, 'B' train, and 'C' train), each consisting of a FWH 1, 2, 3, and 4, are available for normal operation. Drains cascade from FWH 4 to the flash tanks through FWHs 3 and 2. FWH 1 drain to the flash tanks as well. Each flash tank drains to the condenser via the FWH 1 external drain coolers. Emergency drains to the condenser are available for FWHs 4, 3, and 2, as well as the flash tanks.

Four MSR drain trains ('A' train, 'B' train, 'C' train, and 'D' train), each consisting of a moisture separator drain tank (MSDT), 1st stage reheater drain tank (RH1DT), and a 2nd stage reheater drain tank (RH2DT), are available for normal operation as well. The MSDT drains are directed to the HDT. The 1st and 2nd stage reheater drains are directed to FWHs 5 and 7, respectively. Emergency drain lines to the condenser are available for each of the drain lines.

4.2.7.1. Valve Flow Capacity

Valve volumetric flow was computed based on the mass flow rate and fluid temperature. Table 4-23 compares volumetric flow for the baseline (0% TPE) and 30% TPE scenarios.

Table 4-23. Drain Volumetric Flow Comparison

Description	Volumetric Flow Rate (gpm)		Δ (30%)
	0%	30%	
Flash Tank Normal	1,683	1,527	-9.3%
FWH 2 Normal	1,234	1,168	-5.4%
FWH 3 Normal	836	809	-3.2%
FWH 4 Normal	434	419	-3.6%
FWH 6 Normal	2,416	2,086	-13.7%
FWH 7 Normal	1,557	1,346	-13.5%
MSDT Normal	756	433	-42.8%
RHDT1 Normal	331	215	-34.9%
RHDT2 Normal	527	507	-3.9%
Flash Tank Emergency	1,683	1,527	-9.3%
FWH 2 Emergency	1,234	1,168	-5.4%
FWH 3 Emergency	836	809	-3.2%
FWH 4 Emergency	434	419	-3.6%
FWH 5 Emergency	3,890	3,335	-14.3%
FWH 6 Emergency	2,416	2,086	-13.7%
FWH 7 Emergency	1,557	1,346	-13.5%
MSDT Emergency	756	433	-42.8%
RHDT1 Emergency	331	215	-34.9%
RHDT2 Emergency	527	507	-3.9%

As shown above, all drains experience a decrease in flow.

4.2.7.2. Valve Pressure Drop

The pressure drop across the valve is the minimum of the allowable pressure drop due to choked flow and the available pressure drop from valve inlet to outlet based on flow conditions and frictional losses. Pressure loss was computed, as shown in Table 4-24.

Table 4-24. Drain Valve Pressure Loss

Description	Pressure Drop (psid)				Δ (30%)	
	0%		30%			
	Choked	Available	Choked	Available	Choked	Available
Flash Tank Normal	2.7	7.3	2.9	6.2	8.0%	-14.6%
FWH 2 Normal	2.3	3.2	0.5	0.5	-77.6%	-83.4%
FWH 3 Normal	9.1	14.6	4.7	7.6	-48.7%	-48.0%
FWH 4 Normal	32.1	44.5	23.5	32.2	-26.5%	-27.6%
FWH 6 Normal	85.0	95.9	63.3	70.8	-25.5%	-26.2%
FWH 7 Normal	90.9	108.1	65.3	76.9	-28.1%	-28.8%
MSDT Normal	19.6	5.9	15.1	6.5	-23.0%	11.0%
RHDT1 Normal	42.7	249.3	28.1	187.3	-34.0%	-24.9%
RHDT2 Normal	115.6	454.6	116.0	562.4	0.4%	23.7%
Flash Tank Emergency	4.1	9.2	4.1	7.8	-0.7%	-15.1%
FWH 2 Emergency	5.5	11.7	3.7	7.6	-32.5%	-35.0%
FWH 3 Emergency	15.0	37.1	10.6	25.4	-29.1%	-31.4%
FWH 4 Emergency	38.4	92.0	30.0	67.8	-21.9%	-26.3%
FWH 5 Emergency	23.0	196.4	18.5	148.1	-19.4%	-24.6%
FWH 6 Emergency	86.9	283.3	65.3	209.6	-24.9%	-26.0%
FWH 7 Emergency	97.5	405.9	72.0	300.9	-26.1%	-25.9%
MSDT Emergency	16.4	186.0	11.8	137.9	-28.2%	-25.9%
RHDT1 Emergency	47.6	444.7	32.9	333.2	-30.9%	-25.1%
RHDT2 Emergency	116.8	862.6	117.3	865.2	0.4%	0.3%

All drain control valves experience choked flow conditions except the moisture separator drain tank. With respect to valve capacity, a decrease in valve pressure loss is non-conservative; therefore, nearly all valves see a non-conservative reduction in allowable pressure loss. In most cases, the reduction in allowable pressure drop is significant, with FWH 2 normal drains seeing a greater than 80% reduction in pressure drop available.

4.2.7.3. Required Valve C_v

Required valve C_v values are shown in Table 4-25.

Table 4-25. Drain Valve Required C_v Capacity

Description	C_v		Δ (30%)
	0%	30%	
Flash Tank Normal	1019	892	-12.5%
FWH 2 Normal	796	1595	100.5%
FWH 3 Normal	271	367	35.8%
FWH 4 Normal	74	84	13.1%
FWH 6 Normal	245	248	0.9%
FWH 7 Normal	150	155	3.2%
MSDT Normal	292	160	-45.2%
RHDT1 Normal	46	37	-18.8%
RHDT2 Normal	43	41	-4.1%
Flash Tank Emergency	823	751	-8.7%
FWH 2 Emergency	520	600	15.5%
FWH 3 Emergency	211	243	15.4%
FWH 4 Emergency	68	74	9.7%
FWH 5 Emergency	759	731	-3.7%
FWH 6 Emergency	243	244	0.5%
FWH 7 Emergency	145	147	1.7%
MSDT Emergency	175	119	-31.9%
RHDT1 Emergency	43	34	-20.7%
RHDT2 Emergency	43	41	-4.1%

The required C_v capacity for all FWHs increases with 30% TPE. Flash tank and the various MSR drain tanks all see reduced capacity requirements. FWHs 2 and 3 show significant increase in required flow capacity, with FWH 2 requiring approximately double the baseline capacity. It is expected that a station specific review of these FWHs would result in requiring valve replacement prior to 30% TPE operation. Additional equipment changes are not expected, but station specific review is required.

4.2.7.4. Drain Tank Parameters

Table 4-26 provides the operating parameters for the drain tanks (MSDT, RH1DT, RH2DT, and Flash Tank).

Table 4-26. Drain Tank Conditions

Parameter	Units	0%	30%	Δ (30%)
MSDT Drain Flow	lbm/hr	331,167	192,757	-41.8%
RH1DT Drain Flow	lbm/hr	135,811	90,676	-33.2%
RH2DT Drain Flow	lbm/hr	200,488	192,645	-3.9%
Flash Tank Drain Flow	lbm/hr	821,877	749,629	-8.8%
MSDT Drain Pressure	psia	184.6	136.0	-26.3%
RH1DT Drain Pressure	psia	444.2	332.0	-25.3%
RH2DT Drain Pressure	psia	864.2	866.1	0.2%
Flash Tank Drain Pressure	psia	5.42	3.63	-33.0%
MSDT Drain Temperature	°F	375.1	350.8	-24.3°F
RH1DT Drain Temperature	°F	455.0	426.7	-28.3°F
RH2DT Drain Temperature	°F	527.2	527.4	0.3°F
Flash Tank Drain Temperature	°F	165.2	148.4	-16.8°F

Operating parameters for all heater drain system drain tanks either decrease or show minimal change and are expected to operate normally during thermal power extraction operation.

4.2.7.5. Heater Drain Assessment Summary

The required C_v capacity for all the flash tank and the various MSR drain tank drain control valves (DCVs) show reduced capacity requirements when operating with thermal power extraction. DCVs for all FWHs will require greater flow passing capability. FWHs 4, 6, and 7 exhibit required increases of less than 15%, which is typically within the operating margin of a well sized drain control valve. Therefore, no equipment changes would be expected, but a station specific review is required. FWHs 2 and 3, on the other hand, show significant increase in required flow capacity, with FWH 2 requiring approximately double the baseline capacity. Therefore, it is expected that a station specific review of these FWHs would result in requiring valve replacement prior to operation with thermal power extracted for FWHs 2 and 3. Operating parameters for all heater drain system drain tanks either decrease or show minimal change and are expected to operate normally during thermal power extraction operation.

A detailed evaluation of the Heater Drain system is provided in Attachment H.

5. 50% EXTRACTION RESULTS

5.1. THERMAL ANALYSIS

5.1.1. PEPSE

Modifying the generic PEPSE model, plant impacts were assessed for 50% TPE. Table 5-1 provides key information pertaining to plant impacts at this degree of extraction. The PEPSE diagrams provided in Attachment A (pages A29 and A32 to A35) show the results considering the baseline (0% TPE) and 50% TPE cases.

As is described in Section 5.2.7, under the 50% TPE scenario, the FWH 2 normal drain control valve would not meet the required flow capacity, hence operational changes would be expected. One option is to use the FWH 2 and 3 emergency DCVs, which would resolve the operational issues faced by those feedwater heaters with minimal additional PEPSE or equipment impacts compared to 50% TPE. An alternate option is to operate in partial LP FWH bypass, which would circumvent this issue while changing steady state operating conditions for the plant. An additional case is run for this scenario to divert 20% of the condensate flow around the LP FWHs through the bypass line. PEPSE results and equipment evaluations are provided in the remainder of this section for these two (2) 50% TPE scenarios with and without partial LP FWH bypass.

Table 5-1. General Impacts for 50% Thermal Power Extraction

Description	Units	0%	50%	Δ (50%)	50% w/ Bypass	Δ (50% w/ Bypass)
Generator Electric Power	MWe	1,228.0	585.3	-52.3%	573.13	-53.3%
Thermal Power Extracted	MWt	0	1,827	-	1,826.38	-
% of Flow - MS	%	0	37.6	-	37.7	-
MS Flow from SGs	lbm/hr	16,037,390	14,952,560	-7.0%	14,916,170	-7.0%
HP Turbine Inlet Flow	lbm/hr	15,218,400	8,615,524	-43%	8,619,505	-43.4%
HP Turbine First Stage Pressure	psia	651.5	374.8	-42%	375.2	-42.4%
MSR Inlet Pressure	psia	190.3	104.6	-45%	97.6	-48.7%
LP Turbine Inlet Flow	lbm/hr	3,673,069	1,980,267	-46%	1,845,837	-49.7%
LP Turbine Inlet Pressure	psia	175.5	96.43	-45%	90.04	-48.7%
Condenser Duty	BTU/hr	8.21E+09	4.18E+09	-49%	4.22E+09	-48.6%
Condensate Pump Flow	lbm/hr	11,334,490	11,889,450	4.9%	11,475,500	1.2%
Heater Drain Pump Flow	lbm/hr	4,732,792	3,093,006	-35%	3,470,571	-26.7%
Feedwater Pump Flow	lbm/hr	16,067,280	14,982,480	-6.8%	14,946,080	-7.0%
Final Feedwater Temperature	°F	440.9	389.0	-51.9°F	387.1	-53.8°F
Cascading drain Flow to Condenser	lbm/hr	817,619	670,424	-18%	522,171	-36.1%
Reboiler Inlet Mass Flow	lbm/hr	-	5,629,289	-	5,628,542	-
Reboiler Inlet Pressure	psia	-	817.3	-	817.3	-

Description	Units	0%	50%	Δ (50%)	50% w/ Bypass	Δ (50% w/ Bypass)
Reboiler Inlet Temperature	°F	-	520.7	-	520.7	-
Reboiler Inlet Enthalpy	BTU/lbm	-	1,197.2	-	1,197.3	-
Reboiler Outlet Temperature	°F	-	120.0	-	120.0	-
Reboiler Outlet Enthalpy	BTU/lbm	-	90.1	-	90.05	-

5.1.2. Plant Impacts and Considerations

5.1.2.1. Mechanical Transients

Plant operational transients must be assessed for 50% TPE. Transient events will primarily occur during startup and shutdown of the TPE system. Under ~1,825 MWt TPE, approximately 5,630,000 lbm/hr of steam will be sent to the reboilers from Main Steam, corresponding to approximately 38% of Main Steam flow. This TPE will reduce total Main Steam flow by ~1,100,000 lbm/hr, or 7%.

5.1.2.2. Plant Hazards

Existing nuclear power plants are required to be protected from plant hazards such as high-energy line breaks (HELBs). The temperature and pressure limits for HELB are defined as 200°F and 275 psig. As shown in the PEPSE heat balance diagram for 50% TPE in Attachment A, the maximum operating conditions are 532°F and 897 psia. Based on these conditions, this modification would fall under a plant's HELB program.

A review of a plant's specific HELB program should be conducted to assess the impact of the new high-energy lines. Some stations analyze HELBs in the Turbine Building for impact on essential equipment. Any piping additions should be routed in such a way as to be separated from any equipment that may be important to safety or station operation. Any piping additions inside the Turbine Building routing to the steam reboilers are generally expected to be smaller than the main steam line they are tied into. Therefore, the impact of a HELB in the new piping is expected to be bounded by the mass and energy release rates for existing main steam piping. Any piping routed outdoors must also be designed in accordance with the station HELB program.

5.1.2.3. Water/Steam Hammer

During the detailed design of the thermal power extraction system, the potential for water hammer or steam hammer must be addressed. These phenomena could occur if steam or water flow rapidly stops; this condition is typically addressed by selecting appropriate valve closing times.

5.1.2.4. Core Reactivity and Plant Response

Section 4.1.2.4 provides a discussion of the core reactivity effects and plant controls response for the 30% thermal power extraction configuration. For 50% TPE, the description will reflect the same effects, responses, and behaviors, but the effects will be more pronounced. Specifically, the greater reduction in feedwater temperature is noteworthy (refer to Table 5-1). As the explanation of the core's negative MTC describes, the combination of the added steam extraction and reduction in feedwater temperature will create more pronounced reactivity affects for the 50% TPE cases versus the 30% TPE case. When partial LP FWH bypass is employed, feedwater temperature is further lowered. However, this change is relatively small in comparison to the magnitude increase going from 30% to 50% TPE.

From the plant controls response perspective, a sudden loss of heat removal from the 50% TPE configuration will challenge the ability of the response to be limited to plant controls alone. With a Reactor Control System compensation capacity of 10% and a Steam Dump capacity of 40% (typical for the Westinghouse 4-loop PWR design), a sudden loss of a fully loaded TPE system with the nuclear plant operating at 100% power will leave little or no margin for additional actuations (ex., pressurizer relief operation). Evaluation of plant response to a load rejection event, among other transient scenarios, would be required on a site-specific basis.

5.2. EQUIPMENT ASSESSMENT

The effects of 50% TPE on plant secondary equipment has been investigated. A detailed description of the effects on this equipment can be found in Attachments I through O.

5.2.1. Turbine Cycle

A representative turbine cycle was chosen to evaluate the impacts of TPE on turbine performance and operations. The design of the turbine cycle was the same for both the 30% and 50% TPE scenarios; a single HPT and three parallel LPTs were modeled. The representative cycle contains a MSR between the HPT and LPTs, where moisture is removed from the HPT exhaust and heated with two stages of regenerative heating. The turbines provide extraction to seven FWH stages.

The representative turbine cycle performance was modeled in a PEPSE model which contains cases benchmarked to the turbine vendor’s thermal kit. Cases at Valves Wide Open (VWO), rated thermal power (100%), and 50% power are provided.

Turbine performance was assessed for two extraction scenarios: (1) 50% thermal energy extracted from main steam, and (2) 50% thermal energy extracted from main steam with 20% condensate flow bypass around the low-pressure feedwater heaters. Modification to the PEPSE heat balance for these scenarios was performed as documented in Attachment A. The modification included removal of steam from the main steam system and return of the condensate to the main condenser after energy was extracted in the reboiler/s. In the bypass case, the LP FWH bypass valve would be opened to facilitate partial condensate bypass around the LP FWHs.

Table 5-2 shows the change in mass flows at various location along the turbines.

Table 5-2. Mass Flow Comparison

Location	Baseline Mass Flow (lbm/hr)	50% TPE		50% TPE w/ Bypass	
		Mass Flow (lbm/hr)	Percent Change	Mass Flow (lbm/hr)	Percent Change
Throttle Valve Inlet	15,218,400	8,615,524	-43%	8,619,505	-43%
HPT Bowl (Left)	7,609,201	4,307,762	-43%	4,309,753	-43%
Governing Stage Shell (Left)	7,609,201	4,307,762	-43%	4,309,753	-43%
FWH6 Extraction Stage (Left)	6,808,507	3,673,657	-46%	3,589,053	-47%
HPT Exhaust (Left)	6,808,507	3,673,657	-46%	3,589,053	-47%

Location	Baseline Mass Flow (lbm/hr)	50% TPE		50% TPE w/ Bypass	
		Mass Flow (lbm/hr)	Percent Change	Mass Flow (lbm/hr)	Percent Change
HPT Bowl (Right)	7,609,201	4,307,762	-43%	4,309,753	-43%
Governing Stage Shell (Right)	7,609,201	4,307,762	-43%	4,309,753	-43%
FWH7 + RH2 Extraction Stage (Right)	6,550,264	3,736,225	-43%	3,722,015	-43%
HPT Exhaust (Right)	6,550,264	3,736,225	-43%	3,722,015	-43%
LPT A Bowl	3,673,069	1,980,267	-46%	1,845,837	-50%
FWH4A Extraction Stage	3,470,241	1,789,735	-48%	1,704,350	-51%
FWH3A Extraction Stage	3,271,723	1,600,058	-51%	1,562,271	-52%
FWH2A Extraction Stage	3,075,061	1,443,447	-53%	1,436,663	-53%
MR (to FWH1A) Extraction Stage	3,015,812	1,418,517	-53%	1,412,978	-53%
FWH1A Extraction Stage	2,855,450	1,309,843	-54%	1,323,666	-54%
MR (to LPT A Exhaust) Extraction Stage	2,788,284	1,283,649	-54%	1,297,881	-53%
LPT A Exhaust	2,788,284	1,283,649	-54%	1,297,881	-53%
LPT B Bowl	3,673,069	1,980,267	-46%	1,845,837	-50%
FWH4B Extraction Stage	3,468,763	1,788,450	-48%	1,703,682	-51%
FWH3B Extraction Stage	3,273,638	1,600,396	-51%	1,563,189	-52%
FWH2B Extraction Stage	3,068,421	1,437,431	-53%	1,434,512	-53%
MR (to FWH1B) Extraction Stage	3,008,809	1,413,529	-53%	1,411,741	-53%
FWH1B Extraction Stage	2,847,364	1,303,364	-54%	1,321,198	-54%
MR (to LPT B Exhaust) Extraction Stage	2,780,228	1,276,719	-54%	1,294,929	-53%
LPT B Exhaust	2,780,228	1,276,719	-54%	1,294,929	-53%
LPT C Bowl	3,673,069	1,980,267	-46%	1,845,837	-50%
FWH4C Extraction Stage	3,473,448	1,792,958	-48%	1,706,039	-51%
FWH3C Extraction Stage	3,278,225	1,604,687	-51%	1,565,294	-52%
FWH2C Extraction Stage	3,070,612	1,438,541	-53%	1,434,238	-53%
MR (to FWH1C) Extraction Stage	3,011,389	1,413,650	-53%	1,410,563	-53%
FWH1C Extraction Stage	2,850,762	1,304,880	-54%	1,320,862	-54%
MR (to LPT C Exhaust) Extraction Stage	2,783,458	1,278,498	-54%	1,294,859	-53%
LPT C Exhaust	2,783,458	1,278,498	-54%	1,294,859	-53%

5.2.1.1. High-Pressure Turbine

As shown in Table 5-1, across both 50% TPE scenarios, the turbine experiences a reduction in mass flow rate between ~43% and ~54%. Notably, the HPT interstage flows all decrease by a similar margin (43% to 47%). Based on the relatively consistent reduction in flow on either side, additional stress due to imbalanced loading on the turbine is not expected.

HPT performance modeled by PEPSE is visually represented on the Enthalpy-Entropy Chart in Figure 5-1.

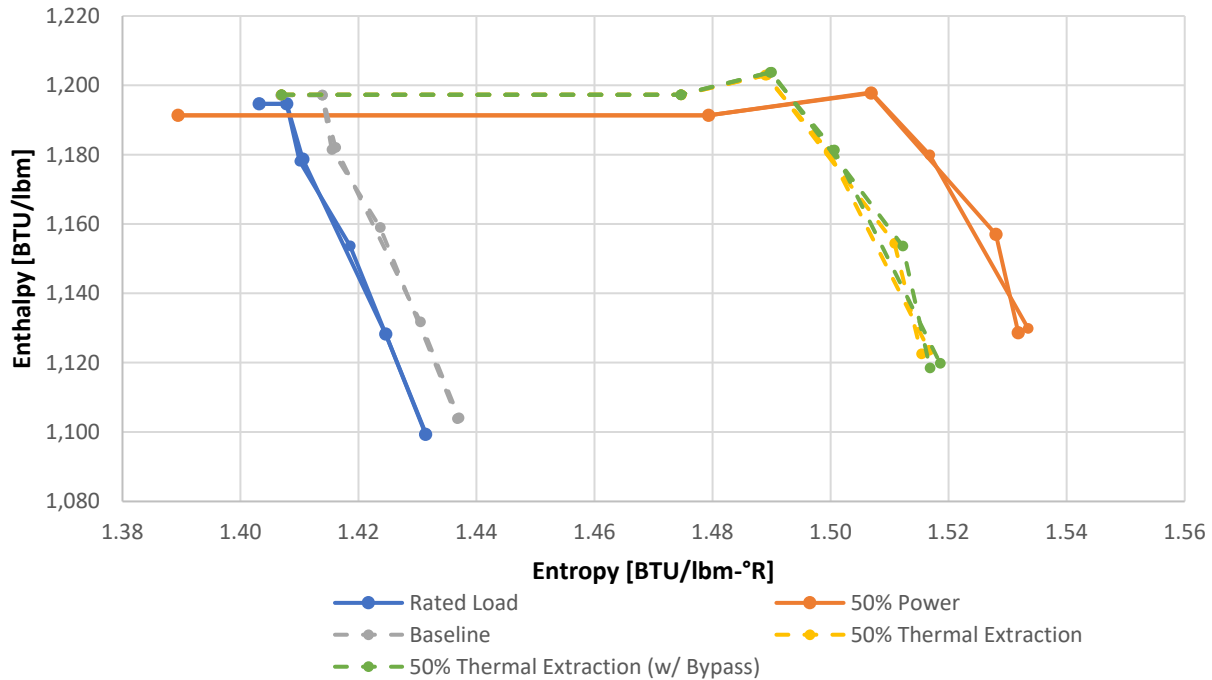

* Rated load and 75% power cases refer to the turbine kit values from the vendor for the specific turbine design. Baseline refers to normal operation with 0% TPE.

Figure 5-1. Enthalpy-Entropy Chart (HPT)

The entropy-enthalpy chart illustrates that the 50% TPE cases trend very closely with the 50% power case. Based on the review of PEPSE heat balance conditions, the turbine is expected to operate within design for the 50% TPE case. However, final acceptability of operation under this condition must be confirmed with the turbine original equipment manufacturer (OEM) on a plant specific basis.

Complete HPT analysis is included as Attachment I.

5.2.1.2. Low Pressure Turbines

As shown in Table 5-1, the LPTs experience a mass flow rate reduction of 46% to 54% when operating in the 50% TPE cases.

The entropy-enthalpy chart for the LPTs is shown below in Figure 5-2.

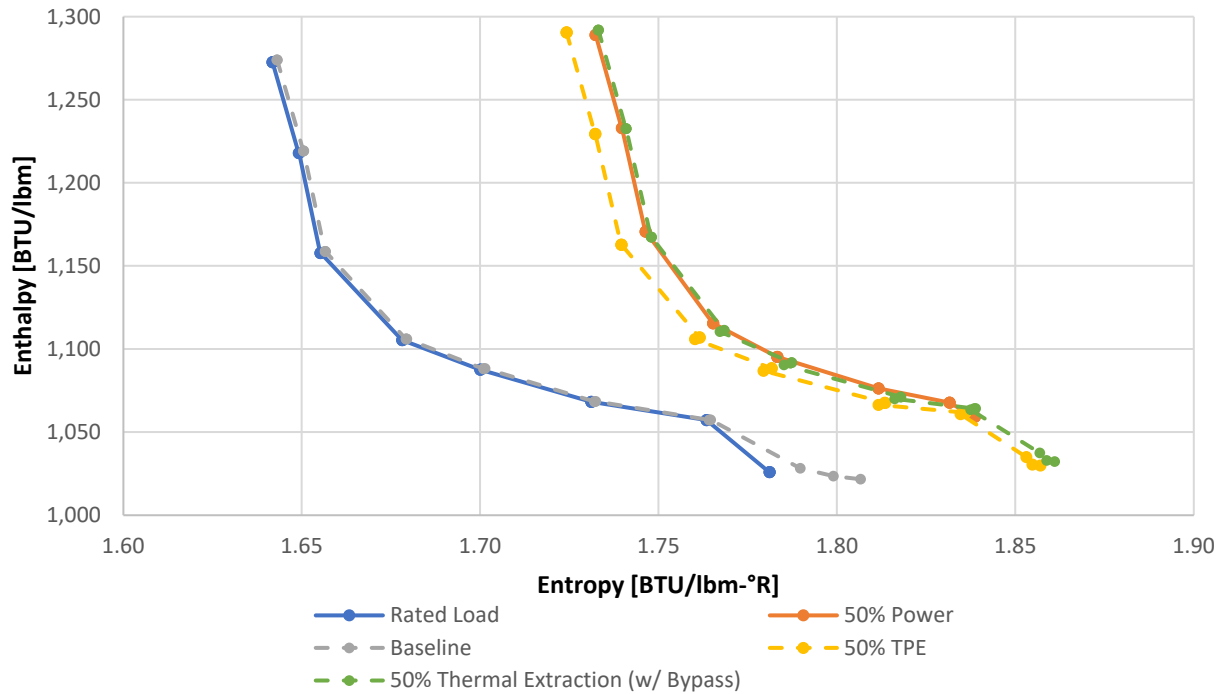

* Rated load and 75% power cases refer to the turbine kit values from the vendor for the specific turbine design. Baseline refers to normal operation with 0% TPE.

Figure 5-2. Enthalpy-Entropy Chart (LPTs)

As in the HPT Enthalpy-Entropy Chart, the 50% TPE case trends very closely with the 50% power case. Based on the review of the PEPSE heat balance conditions, the turbines are expected to operate within design for up to 50% TPE. Final acceptability of operation under this condition must be confirmed with the turbine OEM on a plant specific basis.

Complete analysis of the LPTs is included as Attachment I.

5.2.2. Condensers

The operating conditions of the main condenser were evaluated for the two (2) 50% TPE scenarios, with and without partial LP FWH bypass, with respect to baseline operation.

Required air removal capacity was not specifically evaluated since the major sources of noncondensable gases are not expected to change compared to baseline conditions.

Condenser operating conditions are tabulated below in Table 5-3.

Table 5-3. Condenser Operating Conditions

Description	Units	0%	50%	Δ (50%)	50% w/ Bypass	Δ (50% w/ Bypass)
Condenser A Shell Pressure	psia	1.24	0.87	-29.6%	0.88	-29.5%
Condenser A Shell Flow	lbm/hr	3,120,435	1,581,734	-49.3%	1,585,830	-49.2%
Condenser A Duty	BTU/hr	2.92E+09	1.57E+09	-46.1%	1.58E+09	-45.9%
Condenser B Shell Pressure	psia	1.38	0.90	-34.9%	0.90	-34.5%
Condenser B Shell Flow	lbm/hr	2,850,639	1,306,657	-54.2%	1,324,491	-53.5%
Condenser B Duty	BTU/hr	2.64E+09	1.29E+09	-51.1%	1.31E+09	-50.4%
Condenser C Shell Pressure	psia	1.64	0.99	-39.8%	1.00	-39.4%
Condenser C Shell Flow	lbm/hr	2,854,037	1,308,173	-54.2%	1,324,155	-53.6%
Condenser C Duty	BTU/hr	2.65E+09	1.31E+09	-50.5%	1.33E+09	-49.9%
Hotwell Temperature	°F	115.6	98.1	-17.5°F	98.3	-17.3°F
Condensate Flow	lbm/hr	11,334,490	11,889,450	4.90%	11,475,500	1.2%

The evaluation of condenser operating conditions shows that the condenser will continue to meet operation requirements for 50% TPE conditions, and the evacuation capacity of the condensers is not affected by operating with 50% TPE under either scenario. Condenser steam flow rates, backpressures, and heat loads decrease for the TPE cases; therefore, backpressure limits will not be challenged and flow-induced vibrations will be reduced.

A detailed analysis of the condenser can be found as Attachment J.

5.2.3. Pumps

The power train pump systems evaluated under the 50% TPE scenarios (with and without partial LP FWH bypass) are the CDPs, CBPs, FWPs, and the HDPs, along with the associated HDT control valves. Each system was analyzed through the use of a generic Fathom hydraulic model of the CD, CB, HD forwarding, and FW systems. The condenser pressure, FW flow, HD flow, and water temperatures were taken from the PEPSE Heat Balance results. These conditions are provided in Attachment K.

5.2.3.1. Preferred Operating Region (POR)

Table 5-4 shows the preferred operating region (POR) for the four pumps evaluated. For the CDPs, CBPs, and TDFPs, the percent best efficiency point (BEP) remains within the associated POR, and changes from the base scenario to the 50% TPE cases are minimal. The HDPs experience a significant change in operating point, falling outside of the acceptance criterion by approximately 8% to 15% with and without bypass, respectively. The HDPs will have to be evaluated on a plant-specific basis, and vendors will need to be engaged to determine whether the pumps can appropriately operate at the POR for extended durations. However, it is not expected that any equipment changes will be required.

Table 5-4. Pump Preferred Operating Regions

Pump	Acceptance Criteria	0%	50%	Δ (50%)	50% w/ Bypass	Δ (50% w/ Bypass)
Condensate Pumps (CDP)	70% - 120%	109.6	114.3	4.3%	110.4	0.7%
Condensate Booster Pumps (CBP)	70% - 120%	114.3	119.2	4.3%	115.1	0.7%
Turbine Drain Feed Pump (TDFP)	70% - 120%	99.1	92.4	-6.8%	94.9	-4.3%
Heater Drain Pumps (HDP)	80% - 115%	102.8	65.1	-36.7%	72.0	-29.9%

5.2.3.2. Pump Driver Duty

The power requirement for each pump to perform as hydraulically characterized in the Fathom model is reported as part of the pump performance results. The evaluation of these pump drivers under the baseline and 50% TPE scenarios is tabulated in Table 5-5 below.

Table 5-5. Evaluation of Pump Driver Duty (hp)

Pump	Baseline Mass Flow (lbm/hr)	50% TPE		50% TPE w/ Bypass	
		Mass Flow (lbm/hr)	Percent Change	Mass Flow (lbm/hr)	Percent Change
CDP Gearbox	664	686	3.3%	670	0.9%
CDP/CBP Motor	3157	3253	3.0%	3,184	0.8%
TDFP Turbine	8590	7772	-9.5%	7,188	-16.3%
HDP Motor	1894	1844	-2.6%	1,900	0.3%

The duty on the CDP gearbox and CDP/CBP motor increases slightly for 50% TPE without bypass. These would need to be evaluated against the rated horsepower of their associated drivers. The duty on the TDFP turbine and HDP motor decreases and is expected to meet the acceptance criteria for 50% TPE. In all cases for the bypass scenario, increases are less than 1%, and should continue to meet the acceptance criteria.

5.2.3.3. Net Positive Suction Head (NPSH) Ratio

The NPSH ratio (NPSHa/NPSHr) is a measure of the available suction head margin for a pump. A general acceptance criteria of 2.0 to 2.5 is used for conservatism, depending on the pump.

Table 5-6 provides the NPSH ratio for the evaluated pumps.

Table 5-6. Evaluation of NPSH Ratio

Pump	HI / ANSI Guideline	0%	50%	Δ (50%)	50% w/ Bypass	Δ (50% w/ Bypass)
CDP	≥ 2.0	1.86	1.73	-7.4%	1.87	0.3%
CBP	≥ 2.5	2.86	2.22	-22.4%	2.75	-4.0%
TDFP	≥ 2.5	2.42	4.58	89.0%	5.59	130.7%
HDP	≥ 2.0	16.27	12.58	-22.7%	15.60	-4.1%

The NPSH ratio for the TDFPs significantly improves in both extraction scenarios compared to the baseline scenario. With no LP FWH bypass, the CDP, CBP, and HDP NPSH ratios decrease rather significantly. The CDP and CBP NPSH ratios are below the HI/ANSI guideline for both cases but are not expected to significantly increase the risk of cavitation. Conversely, for the partial LP FWH bypass scenario, only the CDP NPSH ratio is below the HI/ANSI guideline but is shown to actually reduce cavitation risk compared to the baseline scenario. Although no physical changes are expected to the CDPs, CBPs, and HDPs, they should be evaluated for acceptance on a plant-specific basis unless operating under partial bypass.

5.2.3.4. Suction and Discharge Pressure

Suction and discharge pressures for each pump are compared in Table 5-7 below.

Table 5-7. Pump Suction and Discharge Pressures

Pump	0%	50%	Δ (50%)	50% w/ Bypass	Δ (50% w/ Bypass)
	Suction Pressure (psig)				
CDP	-5.1	-5.7	-5.9%	-5.6	-5.0%
CBP	99.2	93.2	-5.3%	98.2	-0.9%
TDFP	425.0	409.4	-3.5%	457.8	7.5%
HDP	184.8	102.1	-41.5%	95.3	-44.9%
Pump	Discharge Pressure (psig)				
CDP	129.5	126.2	-2.3%	129.0	-0.3%
CBP	584.3	564.8	-3.3%	582.7	-0.3%
TDFP	1,130.5	1,115.8	-1.3%	1,115.3	-1.3%
HDP	696.1	795.7	14.0%	772.4	10.7%

Overall, suction and discharge pressures remain relatively unchanged or decrease slightly for the 50% TPE cases. The exceptions are the HDP suction pressure, which decreases by 40-45% under either extraction scenario, and the HDP discharge pressure, which increases by 10-15%. Suction pressures will need to be evaluated on a plant-specific basis to ensure that they do not fall below low alarm setpoints.

5.2.3.5. Turbine Driven Feedwater Pump Speed

The FW flow through the pumps is regulated by the speed of the driving turbine, which receives steam from the main steam system. In the Fathom model, the turbine speed was calculated based on the required flow and developed head required of the TDFPs.

Table 5-8. Evaluation of FWP Turbine Speed

Description	Speed (rpm)				
	0%	50%	Δ (50%)	50% w/ Bypass	Δ (50% w/ Bypass)
Max Calculated Turbine Speed	5,022	4,847	-3.5%	4,702	-6.4%

As shown in Table 5-8 above, the max calculated turbine speed decreases, therefore the margin improves for both 50% TPE cases and is not expected to challenge the TDFP speed acceptance criteria.

5.2.3.6. Heater Drain Tank Level Control Valves

The heater drain tank level control valves are evaluated for controlling margin. Acceptable control margin corresponds to a valve position of less than 50% open, so that each operating valve maintains the ability to pass all of the drain flow.

Table 5-9. Heater Drain Level Control Valve Evaluation

Description	Acceptance Criteria	Valve Position (% Open)			Δ (50%)	Δ (50% w/ Bypass)
		0%	50%	50% w/ Bypass		
HD Level Control Valve	≤ 50%	26.0	13.0	16.5	-50.2%	-36.8%

Based on these results in Table 5-9, the HD tank level control valves meet the acceptance criteria, improving margin for the 50% TPE cases.

5.2.3.7. Power Train Pump Assessment Summary

Based on the analysis above, the changes from baseline operation to 50% TPE on power train pumps are minimal. Pump operating point changes by less than 10% for all pumps except for the heater drain pumps which see a reduction in percent BEP of 30% to 37%. It is not expected that any equipment changes will be needed to address this, but the HDPs will have to be evaluated with plant-specific operating conditions and design margins.

Changes to pump driver duty are also small, although the duty on the CDPs and CBPs increase and will need to be evaluated against the rated horsepower of their associated drivers on a plant-specific basis.

Without bypass, the CDPs and CBPs require plant-specific evaluation due to the ~7% and ~22% decrease in NPSH ratio, respectively. Conversely the 50% TPE scenario with partial LP FWH bypass observes much smaller impacts to these NPSH ratios.

It is not expected that there will be any equipment changes necessary. However, pumps should be evaluated on a plant-specific basis to ensure all acceptance criteria are met.

A detailed pump analysis is provided in Attachment K.

5.2.4. Moisture Separator Reheaters (MSRs)

The MSRs take wet exhaust steam from the HPT and pass it through a series of chevrons to remove moisture. The steam then goes through two stages of heat exchangers where it is heated before being sent to the LPTs.

MSR operating conditions for the baseline (0% TPE) and 50% TPE scenarios (with and without partial LP FWH bypass) are compared in Table 5-10.

Table 5-10. MSR Operating Conditions

Description	Units	0%	50%	Δ (50%)	50% w/ Bypass	Δ (50% w/ Bypass)
MSR Removal Effectiveness	-	0.95	0.95	0.00%	0.95	0.00%
MSR Chevrons Inlet Flow	lbm/hr	3,151,396	1,668,457	-47.1%	1,561,720	-50.4%
MSR Chevrons Inlet Enthalpy	BTU/lbm	1,104	1,123	1.73%	1,119	1.37%
MSR Chevrons Inlet Pressure	psia	190.3	104.6	-45.0%	97.6	-48.7%
MSR 1st Stage Inlet Enthalpy	BTU/lbm	1,193	1,185	-0.68%	1,183	-0.79%
MSR 1st Stage Inlet Pressure	psia	184.6	101.4	-45.0%	94.7	-48.7%
MSR 2nd Stage Inlet Enthalpy	BTU/lbm	1,227	1,217	-0.81%	1,218	-0.74%
MSR 2nd Stage Inlet Pressure	psia	181.8	99.9	-45.0%	93.3	-48.7%

The impacts to the MSRs are primarily a reduction in flow, with minimal change in enthalpies. The approximately 47% to 50% mass flow reduction is similar to 50% power with no TPE. From these results, it is concluded that MSRs will not be affected by 50% TPE operating conditions.

For a detailed analysis of the MSR, refer to Attachment L.

5.2.5. Feedwater Heaters

The CD and FW systems deliver feedwater (condensed steam) to the steam generators. The CD system first directs flow through three parallel strings of low-pressure feedwater heaters (1st point external drain cooler and 1st through 4th point heaters). Flow then passes through two parallel strings of low-pressure feedwater heaters (5th point external drain cooler, 5th and 6th point heaters) to the TDFPs. FW flow then continues through two parallel high pressure feedwater heaters (7th point heaters) to the steam generators. The feedwater heaters receive extraction steam flow and moisture separator reheater drain flow from the turbine system.

The feedwater heaters are evaluated for two scenarios: (1) 50% thermal energy extracted from main steam, and (2) 50% thermal energy extracted from main steam with 20% condensate flow bypass around the low-pressure feedwater heaters. Relevant values from the FWH evaluation are provided below.

5.2.5.1. Nozzle and Tube Velocities

Table 5-11 provides feedwater heater channel end nozzle velocities for the 50% TPE cases.

Table 5-11. Condensate/Feedwater Heater Nozzle Velocities

FW Heater	Velocity (ft/s)				Δ (50%)	Δ (50% w/ Bypass)
	HEI Limit	0%	50%	50% w/ Bypass		
1 st EDC	10	11.9	12.5	12.0	4.9%	1.2%
1 st Point	10	11.9	12.5	12.0	4.9%	1.2%
2 nd Point	10	11.9	12.5	12.0	4.9%	1.2%
3 rd Point	10	11.9	12.5	12.0	4.9%	1.2%
4 th Point	10	11.9	12.5	12.0	4.9%	1.2%
5 th EDC	10	10.0	10.4	10.1	4.9%	1.2%
5 th Point	10	9.6	9.0	8.9	-6.8%	-7.0%
6 th Point	10	9.6	9.0	8.9	-6.8%	-7.0%
7 th Point Inlet	10	10.2	9.5	9.5	-6.8%	-7.0%
7 th Point Outlet	10	15.8	14.7	14.7	-6.8%	-7.0%

Tube side nozzle velocities exceed the HEI guidelines for several of the FWHs and drain coolers; however, changes from the baseline case are small or decrease. As a result, feedwater nozzle wear is not expected to be an issue.

Table 5-12 provides the FWH tube velocities based on the density at average tube temperature.

Table 5-12. FWH Tube Velocities

FW Heater	Velocity (ft/s)				Δ (50%)	Δ (50% w/ Bypass)
	HEI Limit	0%	50%	50% w/ Bypass		
1st EDC	10	10.7	11.2	10.8	4.4%	0.8%
1st Point	10	8.9	9.3	9.0	4.1%	0.5%
2nd Point	10	9.1	9.4	9.1	3.6%	0.1%
3rd Point	10	9.6	9.9	9.6	3.1%	-0.4%
4th Point	10	8.1	8.3	8.0	2.6%	-0.9%
5th EDC	10	7.0	7.1	6.8	2.2%	-2.8%
5th Point	10	9.1	8.3	8.2	-9.4%	-10.4%
6th Point	10	8.5	7.6	7.6	-9.7%	-10.3%
7th Point	10	8.8	7.9	7.9	-10.3%	-10.7%

Tube velocities remain below or marginally exceed the HEI guidelines for the 50% TPE cases. Because changes are small, it is not expected that this will impact FWH and drain cooler tube degradation.

Table 5-13 and Table 5-14 provide the FWH steam inlet and drain outlet nozzle velocities, respectively.

Table 5-13. Steam Inlet Nozzle Velocity

FW Heater	Velocity (ft/s)				Δ (50%)	Δ (50% w/ Bypass)
	HEI Limit	0%	50%	50% w/ Bypass		
1st Point	215	137	215	175	57.3%	27.8%
2nd Point	195	148	272	215	83.7%	45.0%
3rd Point	179	179	348	269	94.5%	50.3%
4th Point	167	156	287	224	84.5%	44.1%
5th Point	156	101	183	282	80.8%	178.6%
6th Point	150	103	150	174	45.6%	69.5%
7th Point	146	80	91	98	13.5%	22.4%

Table 5-14. Drain Outlet Nozzle Velocity

FW Heater	Velocity (ft/s)				Δ (50%)	Δ (50% w/ Bypass)
	HEI Limit	0%	50%	50% w/ Bypass		
1 st EDC	4.0	2.3	1.9	1.5	-18.4%	-36.7%
1 st Point	4.0	1.8	1.1	0.9	-40.0%	-49.2%
2 nd Point	4.0	2.9	2.6	1.9	-11.2%	-32.7%
3 rd Point	4.0	2.4	2.2	1.7	-6.8%	-30.6%
4 th Point	4.0	2.8	2.6	1.9	-8.1%	-32.0%
5 th EDC	4.0	1.8	1.3	1.5	-25.0%	-14.9%
5 th Point	4.0	2.5	1.9	2.1	-25.3%	-14.3%
6 th Point	4.0	2.7	2.0	2.1	-25.1%	-22.5%
7 th Point	4.0	2.2	1.6	1.6	-26.7%	-28.4%

For the 50% TPE scenario with no bypass, steam inlet nozzle velocities for the TPE case increase for all FWHs and exceed the HEI guideline for the 2nd, 3rd, 4th, and 5th point heaters. For the 50% TPE scenario with partial LP FWH bypass, steam inlet nozzle velocities for the TPE case increase for all FWHs and exceed the HEI guideline for the 2nd, 3rd, 4th, 5th, and 6th point heaters. The increases in velocity on the 2nd, 3rd, and 4th point heaters are greater for the scenario with no LP FWH bypass, while the 5th and 6th point heater inlet nozzle velocities are greater for the partial LP FWH bypass scenario. Shell wear rates will likely increase, as it should be noted that changes to steam inlet velocity can affect the wear pattern of the shell. Shear stresses will also likely increase proportional to the velocities. Future inspections should be mindful of these changes. For FWHs inspected less than every outage, there is a high likelihood that inspection frequency will increase. However, a frequency greater than once per outage cycle is not expected. Flow accelerated corrosion (FAC) evaluations should be performed to determine the operating impacts of these increased velocities.

Drain outlet velocities decrease for both TPE cases, so HEI guidelines are not challenged, and wear rates may decrease.

5.2.5.2. Tube Side Pressure Drop

The tube side pressure drop principally affects two design issues, (i) the differential pressure across the pass partition plate (PPP), and (ii) the total pressure drop in the feedwater train.

To review the impact on PPP pressure loss, the change in mass flow rate squared is shown in Table 5-15.

Table 5-15. Pass Partition Plate Pressure Loss

FW Heater	Mass Flow Rate (lbm/hr)			Ratio of Flow Rates (R)				PPP dP	
				50% Extraction vs. Baseline		50% Extraction w/ Bypass vs. Baseline			
	0%	50%	50% w/ Bypass	R	R ²	R	R ²	50%	50% w/ Bypass
1 st EDC	3,778,163	3,963,150	3,825,167	105%	110%	101%	103%	10%	3%
1 st Point	3,778,163	3,963,150	3,825,167	105%	110%	101%	103%	10%	3%
2 nd Point	3,778,163	3,963,150	3,825,167	105%	110%	101%	103%	10%	3%
3 rd Point	3,778,163	3,963,150	3,825,167	105%	110%	101%	103%	10%	3%
4 th Point	3,778,163	3,963,150	3,825,167	105%	110%	101%	103%	10%	3%
5 th EDC	5,667,245	5,944,725	5,737,750	105%	110%	101%	103%	10%	3%
5 th Point	8,033,640	7,491,240	7,473,040	93%	87%	93%	87%	-13%	-13%
6 th Point	8,033,640	7,491,240	7,473,040	93%	87%	93%	87%	-13%	-13%
7 th Point	8,033,640	7,491,240	7,473,040	93%	87%	93%	87%	-13%	-13%

The pressure loss across the PPP is expected to increase in FWHs 1 through 4 and both external drain coolers. However, the expected increase in tube side pressure drop for the TPE case is not expected to appreciably impact reliable operation of the heaters. This increase is less pronounced in the partial LP FWH bypass scenario compared to the case with no bypass.

5.2.5.3. Drain Inlet Nozzle Mass Flux

The mass flux and mass flux parameter of flashing condensate flows entering the shell side of the FWHs are provided in Table 5-16 and Table 5-17 for the two (2) 50% TPE scenarios.

Table 5-16. Heater Drain Inlet Nozzle Mass Flux and Mass Flux Parameter for 50% Thermal Power Extraction

FW Heater	Mass Flux (lbm/s/ft ²)				Mass Flux Parameter (lbm/ft/s ²)			
	HEI Limit	0%	50%	Δ (50%)	HEI Limit	0%	50%	Δ (50%)
1 st EDC	250	141	116	-18.0%	4,000	4,755	3,704	-22.1%
2 nd Point	250	148	140	-5.3%	4,000	6,491	7,663	18.1%
3 rd Point	250	179	168	-6.1%	4,000	4,141	5,177	25.0%
5 th EDC	250	102	78	-23.0%	4,000	199	109	-42.4%
5 th Point (cascading)	250	188	145	-22.6%	4,000	647	375	-42.0%
5 th Point (MSR)	250	119	56	-53.1%	4,000	4409	1,480	-66.4%
6 th Point	250	118	90	-23.7%	4,000	515	291	-43.6%
7 th Point	250	112	96	-13.9%	4,000	2,177	3,878	78.1%

Table 5-17. Heater Drain Inlet Nozzle Mass Flux and Mass Flux Parameter for 50% Thermal Power Extraction with Partial LP FWH Bypass

FW Heater	Mass Flux (lbm/s/ft ²)				Mass Flux Parameter (lbm/ft/s ²)			
	HEI Limit	0%	50% w/ Bypass	Δ (50% w/ Bypass)	HEI Limit	0%	50% w/ Bypass	Δ (50% w/ Bypass)
1 st EDC	250	141	90	-36.4%	4,000	4,755	1,385	-70.9%
2 nd Point	250	148	105	-29.3%	4,000	6,491	3,249	-49.9%
3 rd Point	250	179	125	-30.4%	4,000	4,141	2,139	-48.4%
5 th EDC	250	102	90	-11.3%	4,000	190	144	-24.0%
5 th Point (cascading)	250	188	151	-19.6%	4,000	647	403	-37.7%
5 th Point (MSR)	250	119	56	-53.4%	4,000	4409	1,632	-63.0%
6 th Point	250	118	88	-25.4%	4,000	515	261	-49.4%
7 th Point	250	112	91	-18.8%	4,000	2,177	3,549	63.0%

For the 50% TPE case with no LP FWH bypass, drain inlet mass fluxes remain below HEI guidelines, but the mass flux parameters for the 2nd and 3rd point heaters exceed the guidelines for the TPE case. Under the partial LP FWH bypass scenario, none of the mass fluxes or mass flux parameters exceed HEI guidelines.

For most FWHs, the mass flux parameter decreases, or the increase is small (<25%). The FWH 7 inlet mass flux parameter increases by 60-80% between the two scenarios, caused by the change in density from the lower shell pressure. If the subject station does not show sufficient margin to allow for this increase, additional flashing steam could increase wear rates at the drain inlet. Future inspections should be mindful for changes.

5.2.5.4. Operating Pressure and Temperature

Shell side operating pressure and temperature is provided in Table 5-18. Tube side operating temperature is provided in Table 5-19.

Table 5-18. Shell Side Operating Pressures and Temperatures

FW Heater	Pressure (psia)					Temperature (°F)				
	0%	50%	Δ (50%)	50% w/ Bypass	Δ (50% w/ Bypass)	0%	50%	Δ (50%)	50% w/ Bypass	Δ (50% w/ Bypass)
1 st EDC	5.4	2.4	-55.1%	2.5	-54.4%	165.6	133.3	-32.3°F	133.9	-31.7°F
1 st Point	5.4	2.4	-55.1%	2.5	-54.4%	165.6	133.3	-32.3°F	133.9	-31.7°F
2 nd Point	15.9	7.3	-54.0%	7.3	-54.0%	215.9	178.8	-37.1°F	178.8	-37.1°F
3 rd Point	40.6	19.7	-51.5%	19.4	-52.3%	268.1	227.1	-41.0°F	226.2	-41.8°F
4 th Point	89.5	46.8	-47.8%	44.7	-50.0%	319.9	276.8	-43.1°F	274.1	-45.8°F
5 th EDC	186.1	102.3	-45.0%	95.5	-48.7%	375.8	329.5	-46.4°F	324.5	-51.3°F

FW Heater	Pressure (psia)					Temperature (°F)				
	0%	50%	Δ (50%)	50% w/ Bypass	Δ (50% w/ Bypass)	0%	50%	Δ (50%)	50% w/ Bypass	Δ (50% w/ Bypass)
5 th Point	186.1	102.3	-45.0%	95.5	-48.7%	375.8	329.5	-46.4°F	324.5	-51.3°F
6 th Point	287.1	161.3	-43.8%	157.5	-45.1%	413.3	364.2	-49.1°F	362.3	-51.1°F
7 th Point	408.7	229.2	-43.9%	224.5	-45.1%	446.7	393.4	-53.3°F	391.6	-55.1°F

Table 5-19. Tube Side Operating Temperatures

FW Heater	Temperature (°F)			Δ (50%)	Δ (50% w/ Bypass)
	0%	50%	50% w/ Bypass		
1 st EDC	126.6	103.9	104.1	-22.4°F	-22.2°F
1 st Point	161.7	129.0	130.8	-32.1°F	-30.2°F
2 nd Point	212.8	170.7	173.7	-39.5°F	-36.4°F
3 rd Point	265.0	221.2	222.9	-41.9°F	-40.2°F
4 th Point	316.4	270.2	270.2	-44.2°F	-44.1°F
5 th EDC	332.2	283.1	258.1	-48.3°F	-73.3°F
5 th Point	370.2	323.6	315.6	-46.3°F	-54.3°F
6 th Point	409.7	360.9	358.4	-48.6°F	-51.1°F
7 th Point	441.5	388.5	386.5	-51.8°F	-53.7°F

Operating temperatures and pressures decrease for all FWHe, therefore margins with design values will improve for the TPE case.

5.2.5.5. Drain Cooler Tube Vibration

Tube vibration in the 1st through 7th point heater drain coolers is evaluated by comparing the drain cooler volumetric flow rates. Results are provided in Table 5-20 below.

Table 5-20. Drain Cooler Vibration

FW Heater	Drain Volumetric Flow Rate (gpm)			Δ (50%)	Δ (50% w/ Bypass)
	0%	50%	50% w/ Bypass		
1 st EDC	1,671	1,364	1,058	-18.4%	-36.7%
2 nd Point	1,240	1,101	835	-11.2%	-32.7%
3 rd Point	842	784	585	-6.8%	-30.6%
4 th Point	439	404	299	-8.1%	-32.0%
5 th EDC	3,767	2,826	3,205	-25.0%	-14.9%
6 th Point	2,434	1,824	1,887	-25.1%	-22.5%
7 th Point	1,578	1,157	1,130	-26.7%	-28.4%

The volumetric flow through all drain coolers is expected to decrease during operation, resulting in increased margin for tube vibration parameters.

5.2.5.6. Feedwater Heater Assessment Summary

Tube and tube side nozzle velocities exceed the HEI guidelines for several of the FWHs and drain coolers, but changes from the baseline case are small or decrease, therefore it is not expected that flashing, tube degradation, or nozzle wear will be an issue. Steam inlet nozzle velocities exceed HEI guidelines for the 2nd, 3rd, 4th, 5th, and 6th (for partial LP FWH bypass scenario only) point heaters. This increase is more pronounced on the 5th and 6th point FWHs when partial bypass is implemented and could affect wear patterns of the shells. Evaluations should be performed on a site-specific basis to assess the impact of velocity increases on station FAC programs and inspection frequency.

Tube side pressure drop for the TPE case is not expected to appreciably impact heater reliability. Drain inlet mass fluxes remain below HEI guidelines, but the mass flux parameters for various heaters exceed the guidelines with no bypass. Implementing bypass nullifies this issue.

Operating temperatures and pressures decrease for all FWHs, therefore design margins will improve for the TPE case. Volumetric flow through all drain coolers is also expected to decrease during TPE operation, resulting in increased margin for tube vibration parameters.

It is not anticipated that feedwater heaters replacement will be required for 50% TPE. However, normal plant inspections would remain suitable to identify potential flow accelerated corrosion issues.

A detailed evaluation of the feedwater heaters is provided in Attachment M.

5.2.6. Extraction Steam

The ES system diverts steam taken from the turbine to the feedwater heaters. There are three stages of extraction from the HPT and four stages of extraction from each LPT. The Extraction Steam is used to heat the feedwater in seven separate feedwater heater stages.

There are three trains for the 1st through 4th point LP feedwater heaters, two trains for the 5th and 6th point LP feedwater heaters, and two trains for the 7th point HP feedwater heater.

Heat balance data for the baseline and 50% TPE scenarios (with and without partial LP FWH bypass) is discussed below.

5.2.6.1. Pressure Drop

Table 5-21 shows the pressure drop in the ES lines.

Table 5-21. Extraction Steam Line Pressure Drop

Description	Upstream Pressure (psia)					Pressure Drop (psid)				
	0%	50%	50% w/ Bypass	Δ (50%)	Δ (50% w/ Bypass)	0%	50%	50% w/ Bypass	Δ (50%)	Δ (50% w/ Bypass)
HPT to 7th Stg FWH	451.0	258.4	257.5	-42.7%	-42.9%	6.50	4.53	5.15	-30.2%	-20.7%
HPT to 6th Stg FWH	296.5	166.6	162.7	-43.8%	-45.1%	8.46	9.76	12.91	15.3%	52.6%
HPT to 5th Stg FWH	190.3	104.6	97.6	-45.0%	-48.7%	4.97	8.81	19.67	77.4%	295.9%
LPT to 4th Stg FWH	92.39	48.34	46.18	-47.7%	-50.1%	4.33	7.49	4.34	73.0%	0.3%
LPT to 3rd Stg FWH	41.9	20.36	19.96	-51.4%	-52.4%	3.24	6.02	3.49	85.6%	7.5%
LPT to 2nd Stg FWH	16.43	7.581	7.56	-53.9%	-54.0%	0.78	1.15	0.71	46.7%	-8.5%
LPT to 1st Stg FWH	5.428	2.441	2.472	-55.0%	-54.5%	0.13	0.13	0.09	-4.8%	-34.4%

For the scenario with no LP FWH bypass, the pressure drop in the lines from the HPT to 7th stage FWHs and LPTs to 1st stage FWHs decreases, but all other extraction steam lines see an increase in pressure drop for the 50% TPE case due to higher flow velocities. The most significant changes are in lines to the 3rd, 4th, and 5th stage FWHs which have an increase in pressure drop of greater than 70%.

With the addition of partial low pressure FWH bypass, the increased pressure drop at the 5th and 6th stage FWHs becomes significantly more pronounced. For the 5th stage heater specifically, the pressure drop is approximately 20% of the upstream pressure.

5.2.6.2. Operating Conditions

ES line pressures and temperatures are compared below in Table 5-22.

Table 5-22. Extraction Steam Line Operating Conditions

Description	Line Pressure (psia)					Line Temperature (°F)				
	0%	50%	50% w/ Bypass	Δ (50%)	Δ (50% w/ Bypass)	0%	50%	50% w/ Bypass	Δ (50%)	Δ (50% w/ Bypass)
HPT to 1st Stg Rhtr	448.7	257.1	256.2	-42.7%	-42.9%	456.5	403.9	403.6	-52.6°F	-52.9°F
HPT to 7th Stg FWH	408.7	229.2	224.5	-43.9%	-45.1%	456.5	403.9	403.6	-52.6°F	-52.9°F
HPT to 6th Stg FWH	287.1	161.3	157.5	-43.8%	-45.1%	416.3	366.8	364.9	-49.5°F	-51.4°F
HPT to 5th Stg FWH	186.1	102.3	95.5	-45.0%	-48.7%	377.6	331.1	326.1	-46.6°F	-51.6°F
LPT to 4th Stg FWH	89.6	46.9	44.8	-47.7%	-50.0%	382.5	388.6	394.3	6.1°F	11.8°F
LPT to 3rd Stg FWH	40.6	19.7	19.4	-51.4%	-52.3%	270.1	241.5	250.5	-28.6°F	-19.5°F
LPT to 2nd Stg FWH	15.9	7.3	7.3	-53.9%	-54.0%	217.7	180.4	180.3	-37.3°F	-37.4°F
LPT to 1st Stg FWH	5.4	2.4	2.5	-55.0%	-54.5%	165.7	133.5	134.0	-32.2°F	-31.7°F

Pressures and temperatures decrease for the TPE case in all lines other than a small temperature increase (~10°F) in the 4th Stg FWH line, therefore design margins will largely improve.

5.2.6.3. Expansion Joint Liner Thickness

Required liner thicknesses are compared in Table 5-23.

Table 5-23. Expansion Joint Liner Thickness

Description	Required Liner Thickness (in)			Δ (50%)	Δ (50% w/ Bypass)
	0%	50%	50% w/ Bypass		
LPT to 4th Stg FWH	0.137	0.186	0.164	35.7%	20.0%
LPT to 3rd Stg FWH	0.138	0.193	0.170	39.4%	22.6%
LPT to 2nd Stg FWH	0.156	0.211	0.188	35.4%	20.4%
LPT to 1st Stg FWH	0.149	0.187	0.169	25.3%	13.1%

Liner thickness requirements increase for the TPE case. Existing expansion joints will need to be evaluated on a plant-specific basis and may need to be replaced to ensure they meet required thicknesses.

5.2.6.4. Extraction Steam Assessment Summary

Analysis of the extraction steam system for the 50% TPE scenarios shows that extraction steam line pressure drops increase in general due to higher flow velocities, with lines to the 3rd, 4th, 5th, and 6th (for the partial LP FWH bypass scenario only) stage feedwater heaters seeing significant increases. Expansion joint liner thickness requirements also increase in both cases, although these increases are less significant for the partial LP FWH bypass scenario. Existing expansion joints will need to be evaluated on a plant-specific basis and may need to be replaced to ensure they meet these new requirements.

Pressures and temperatures decrease during operation with TPE, with the exception of a small temperature increase (~10°F) in the 4th Stage FWH extraction line. This slight increase is expected to be within the design margin of a typical plant, with the other margins improving.

Refer to Attachment N for a detailed evaluation of the Extraction Steam system.

5.2.7. Heater Drain System

The FWH drain system design for 50% TPE is the same as the design for 30% TPE. This system is comprised of seven stages of feedwater heating for normal operations. System impacts under the two (2) 50% TPE cases are assessed below.

5.2.7.1. Valve Flow Capacity

Valve volumetric flow is computed based on the mass flow rate and fluid temperature.

Table 5-24 compares volumetric flow for the baseline and 50% TPE scenarios.

Table 5-24. Drain Volumetric Flow Comparison

Description	Volumetric Flow Rate (gpm)			Δ (50%)	Δ (50% w/ Bypass)
	0%	50%	50% w/ Bypass		
Flash Tank Normal	1,683	1,367	1,062	-18.8%	-36.9%
FWH 2 Normal	1,234	1,096	833	-11.2%	-32.5%
FWH 3 Normal	836	781	582	-6.6%	-30.4%
FWH 4 Normal	434	399	297	-8.1%	-31.7%
FWH 6 Normal	2,416	1,814	1,876	-24.9%	-22.3%
FWH 7 Normal	1,557	1,144	1,117	-26.5%	-28.3%
MSDT Normal	756	257	248	-66.0%	-67.1%
RHDT1 Normal	331	148	147	-55.2%	-55.4%
RHDT2 Normal	527	455	429	-13.8%	-18.7%
Flash Tank Emergency	1,683	1,367	1,062	-18.8%	-36.9%
FWH 2 Emergency	1,234	1,096	833	-11.2%	-32.5%
FWH 3 Emergency	836	781	291	-6.6%	-65.2%
FWH 4 Emergency	434	399	297	-8.1%	-31.7%
FWH 5 Emergency	3,890	2,910	3,333	-25.2%	-14.3%
FWH 6 Emergency	2,416	1,814	1,876	-24.9%	-22.3%
FWH 7 Emergency	1,557	1,144	1,117	-26.5%	-28.3%
MSDT Emergency	756	257	248	-66.0%	-67.1%
RHDT1 Emergency	331	148	147	-55.2%	-55.4%
RHDT2 Emergency	527	455	429	-13.8%	-18.7%

As shown above, all drains experience a decrease in flow.

5.2.7.2. Valve Pressure Drop

The pressure drop across the valve is the minimum of the allowable pressure drop due to choked flow and the available pressure drop from valve inlet to outlet based on flow conditions and frictional losses. Pressure loss is computed in Table 5-25.

Table 5-25. Drain Valve Pressure Loss for 50% Thermal Power Extraction

Description	Pressure Drop (psid)						Δ (50%)		Δ (50% w/ Bypass)	
	0%		50%		50% w/ Bypass		Choked	Available	Choked	Available
	Choked	Available	Choked	Available	Choked	Available				
Flash Tank Normal	2.7	7.3	3.1	5.6	3.5	6.2	16.0%	-23.4%	31.2%	-14.8%
FWH 2 Normal	2.3	3.2	-0.6	-1.1	1.0	1.2	-126.3%	-134.0%	-57.5%	-62.3%
FWH 3 Normal	9.1	14.6	1.7	2.9	3.8	5.5	-81.2%	-79.8%	-58.6%	-62.1%
FWH 4 Normal	32.1	44.5	17.4	23.4	17.7	23.9	-45.6%	-47.4%	-44.9%	-46.1%
FWH 6 Normal	85.0	95.9	48.8	54.5	52.1	57.4	-42.6%	-43.1%	-38.7%	-40.2%
FWH 7 Normal	90.9	108.1	47.8	54.7	47.9	53.9	-47.4%	-49.4%	-47.3%	-50.1%
MSDT Normal	19.6	5.9	12.2	7.0	11.7	7.0	-37.8%	18.4%	-40.5%	19.8%
RHDT1 Normal	42.7	249.3	19.0	145.3	18.9	151.2	-55.5%	-41.7%	-55.7%	-39.4%
RHDT2 Normal	115.6	454.6	117.0	641.0	117.5	647.9	1.3%	41.0%	1.7%	42.5%
Flash Tank Emergency	4.1	9.2	4.0	6.9	4.1	7.0	-1.0%	-25.3%	-0.4%	-24.2%
FWH 2 Emergency	5.5	11.7	2.6	5.0	4.3	7.3	-52.7%	-57.2%	-22.5%	-37.3%
FWH 3 Emergency	15.0	37.1	7.8	17.6	9.9	20.3	-48.3%	-52.6%	-34.0%	-45.2%
FWH 4 Emergency	38.4	92.0	24.0	50.8	24.3	51.2	-37.6%	-44.8%	-36.7%	-44.4%
FWH 5 Emergency	23.0	196.4	15.7	113.7	15.2	106.9	-31.7%	-42.1%	-34.0%	-45.6%
FWH 6 Emergency	86.9	283.3	50.8	158.7	54.1	154.7	-41.6%	-44.0%	-37.8%	-45.4%
FWH 7 Emergency	97.5	405.9	54.6	227.5	54.8	222.8	-44.0%	-44.0%	-43.8%	-45.1%
MSDT Emergency	16.4	186.0	8.8	103.5	8.2	96.8	-46.4%	-44.3%	-49.7%	-47.9%
RHDT1 Emergency	47.6	444.7	23.7	256.2	23.6	255.3	-50.2%	-42.4%	-50.4%	-42.6%
RHDT2 Emergency	116.8	862.6	118.5	870.8	119.1	873.3	1.5%	1.0%	2.0%	1.2%

All drain control valves experience choked flow conditions except for the moisture separator drain tank and FWH 2 under normal operating conditions. The FWH 2 normal drain control valve exhibits excessive inlet and outlet pressure drop resulting in a negative pressure loss, which is not possible. Adjustments to the plant operation (opening of the emergency dump valve or opening of the LP FWH bypass) would be required in order to maintain normal operation under 50% TPE.

To address the negative pressure loss issue faced by FWH 2 normal DCV, the partial LP FWH bypass scenario is developed, using 20% condensate flow bypass. Under this scenario, it is observed that the drain control valve experiences choked flow with a pressure drop of 1 psi. Similar to the no LP FWH bypass scenario, a majority of the valves experience a non-conservative reduction in allowable pressure loss.

5.2.7.3. Required Valve C_v

Required valve C_v values are shown in Table 5-26.

Table 5-26. Drain Valve Required C_v Capacity

Description	C _v			Δ (50%)	Δ (50% w/ Bypass)
	0%	50%	50% w/ Bypass		
Flash Tank Normal	1019	772	565	-24.2%	-44.6%
FWH 2 Normal	796	N/A	829	N/A	4.2%
FWH 3 Normal	271	588	295	117.2%	9.1%
FWH 4 Normal	74	93	69	26.0%	-7.0%
FWH 6 Normal	245	247	248	0.7%	1.0%
FWH 7 Normal	150	155	151	3.4%	0.9%
MSDT Normal	292	93	89	-68.3%	-69.4%
RHDT1 Normal	46	31	31	-31.3%	-31.5%
RHDT2 Normal	43	37	34	-14.4%	-19.5%
Flash Tank Emergency	823	675	523	-18.0%	-36.4%
FWH 2 Emergency	520	675	401	29.8%	-22.9%
FWH 3 Emergency	211	276	182	31.0%	-13.6%
FWH 4 Emergency	68	79	59	17.6%	-13.2%
FWH 5 Emergency	759	715	856	-5.9%	12.8%
FWH 6 Emergency	243	242	243	-0.2%	0.3%
FWH 7 Emergency	145	145	142	0.1%	-2.3%
MSDT Emergency	175	82	82	-52.8%	-52.8%
RHDT1 Emergency	43	28	28	-35.1%	-35.2%
RHDT2 Emergency	43	36	34	-14.5%	-19.6%

The required C_v capacity for the low-pressure FWHs increases significantly with 50% thermal power extraction and no LP FWH bypass. FWHs 6 and 7 exhibit required increases of less than 5%, which is typically within the operating margin of a well sized drain control valve. Therefore, no equipment changes would be expected for these FWH DCVs, but a station specific review is required. FWH 4 DCVs require an increased C_v capacity of 18% to 26% and would require station specific review for valve acceptability. FWH 3 normal and emergency DCVs shows significantly increased flow capacity requirements, and would likely both need to be replaced, along with the FWH 2 emergency DCV. For the reference plant, the FWH 2 normal DCV cannot meet the flow capacity requirements of 50% TPE and would require operational and/or design changes in order to satisfy system requirements. This would need to be determined based on the plant specific evaluation. Flash tank and the various MSR drain tanks all see reduced capacity requirements and remain acceptable.

To address the flow capacity issue on the FWH 2 normal DCV, the 20% condensate flow bypass scenario is developed. With this operational change nearly all FWH DCVs experience a reduction or insignificant increase in required C_v , with the FWH 2 and 3 normal DCVs and FWH 5 emergency DCV being the only exceptions. Station specific review would be required to determine if valve/trim replacements are needed.

5.2.7.4. Drain Tank Parameters

The operating parameters for the MSDT, RH1DT, RH2DT, and Flash Tank are reviewed in Table 5-27.

Table 5-27. Drain Tank Conditions

Parameter	Units	0%	50%	50% w/ Bypass	Δ (50%)	Δ (50% w/ Bypass)
MSDT Drain Flow	lbm/hr	331,167	116,108	112,625	-64.9%	-66.0%
RH1DT Drain Flow	lbm/hr	135,811	63,649	63,355	-53.1%	-53.4%
RH2DT Drain Flow	lbm/hr	200,488	172,593	162,685	-13.9%	-18.9%
Flash Tank Drain Flow	lbm/hr	821,877	674,238	523,929	-18.0%	-36.3%
MSDT Drain Pressure	psia	184.6	101.4	94.7	-45.0%	-48.7%
RH1DT Drain Pressure	psia	444.2	254.6	253.7	-42.7%	-42.9%
RH2DT Drain Pressure	psia	864.2	870.5	872.5	0.7%	1.0%
Flash Tank Drain Pressure	psia	5.42	2.43	2.47	-55.1%	-54.5%
MSDT Drain Temperature	°F	375.1	328.8	323.9	-46.3°F	-51.2°F
RH1DT Drain Temperature	°F	455.0	402.6	402.3	-52.4°F	-52.7°F
RH2DT Drain Temperature	°F	527.2	528.0	528.3	0.8°F	1.1°F
Flash Tank Drain Temperature	°F	165.2	132.6	133.4	-32.6°F	-31.8°F

Mass flow rates decrease for all drain tanks. Pressure and temperatures also decrease for all tanks except the 2nd stage reheater drain tank, which marginally increases. As a result, the heater drain system drain tanks are expected to operate normally during thermal power extraction operation.

5.2.7.5. Heater Drain Assessment Summary

The required C_v capacity for all the flash tank and the various MSR drain tanks DCVs show reduced capacity requirements when operating with 50% thermal power extraction. With no LP FWH bypass, the DCVs for a majority of the feedwater heaters would require greater flow passing capability. FWHs 6 and 7 exhibit required increases of less than 5%, therefore no equipment changes are expected. FWH 4 requirements increase by 26% and will require station specific review to determine if valve replacement is necessary. FWHs 2 and 3 show significant increases in required flow capacity, with the FWH 2 normal DCV not being able to support 50% TPE without use of the emergency DCV or partial LP FWH bypass. The partial LP FWH bypass scenario was run to assess this alternate case. Station specific review may determine that replacement of the FWH 2 and 3 DCVs is sufficient to address this issue without any plant operating changes.

By modifying plant operation by allowing for 20% condensate flow bypass around the low-pressure feedwater heaters, the increase in required flow capacity for the feedwater heaters is significantly reduced. Through this change, the FWH 2 and 3 normal DCVs experience increases in required C_v of less than 10% and should be evaluated to determine if replacement would be needed on a site-specific basis. All other DCVs should experience a decrease in C_v or negligible (<1%) increase and are not expected to require replacement. However, this may require modification to the LP FWH bypass valve to allow for specified flow control.

Operating parameters for all heater drain system drain tanks either decrease or show minimal change and are expected to operate normally during thermal power extraction operation.

A detailed evaluation of the Heater Drain system is provided in Attachment O.

6. 70% EXTRACTION RESULTS

6.1. THERMAL ANALYSIS

6.1.1. PEPSE

Modifying the generic PEPSE model, plant impacts were assessed for 70% TPE. Table 6-1 provides key information pertaining to plant impacts at this degree of extraction. The PEPSE diagrams provided in Attachment A (pages A29, A36, and A37) show the results considering the baseline (0% TPE) and 70% TPE cases.

Table 6-1. General Impacts for 70% Thermal Power Extraction

Description	Units	0%	70%	Δ (70%)
Generator Electric Power	MWe	1,228.0	327.3	-73.3%
Thermal Power Extracted	MWt	0	2,557	-
% of Flow - MS	%	0	55.0	-
MS Flow from SGs	lbm/hr	16,037,390	14,316,180	-10.7%
HP Turbine Inlet Flow	lbm/hr	15,218,400	5,893,152	-61.3%
HP Turbine First Stage Pressure	psia	651.5	260.4	-60.0%
MSR Inlet Pressure	psia	190.3	65.5	-65.6%
LP Turbine Inlet Flow	lbm/hr	3,673,069	1,230,440	-66.5%
LP Turbine Inlet Pressure	psia	175.5	60.4	-65.6%
Condenser Duty	BTU/hr	8.21E+09	2.57E+09	-68.7%
Condensate Pump Flow	lbm/hr	11,334,490	11,900,900	5.0%
Heater Drain Pump Flow	lbm/hr	4,732,792	2,445,181	-48.3%
Feedwater Pump Flow	lbm/hr	16,067,280	14,346,080	-10.7%
Final Feedwater Temperature	°F	440.9	354.0	-86.9°F
Cascading drain Flow to Condenser	lbm/hr	817,619	542,768	-33.6%
Reboiler Inlet Mass Flow	lbm/hr	-	7,878,196	-
Reboiler Inlet Pressure	psia	-	817.3	-
Reboiler Inlet Temperature	°F	-	520.7	-
Reboiler Inlet Enthalpy	BTU/lbm	-	1,197.3	-
Reboiler Outlet Temperature	°F	-	120.0	-
Reboiler Outlet Enthalpy	BTU/lbm	-	90.1	-

6.1.2. Plant Impacts and Considerations

6.1.2.1. Mechanical Transients

Plant operational transients must be assessed for 70% TPE. Transient events will primarily occur during startup and shutdown of the extraction system. Under ~2,550 MWt extraction, approximately 7,880,000 lbm/hr of steam will be sent to the reboilers from Main Steam, corresponding to approximately 55% of Main Steam flow. This TPE will reduce total Main Steam flow by ~1,720,000 lbm/hr, or 10.7%.

6.1.2.2. Plant Hazards

Similar to the 30% and 50% scenarios, plant's HELB programs will be impacted by this modification and new piping will need to be routed in such a way as to be separated from any equipment that may be important to safety or station operation.

During the detailed design of the thermal power extraction system, the potential for water hammer or steam hammer must be addressed. These phenomena could occur if steam or water flow rapidly stops; this condition is typically addressed by selecting appropriate valve closing times.

6.1.2.3. Core Reactivity and Plant Response

Section 4.1.2.4 provides a discussion of the core reactivity effects and plant controls response for the 30% thermal power extraction configuration. For 70% TPE, the description will reflect the same effects, responses, and behaviors, but the effects will be more pronounced than the 30% and 50% cases. Specifically, the greater reduction in feedwater temperature is noteworthy (refer to Table 6-1).

From the plant controls response perspective, a sudden loss of heat removal from the 70% TPE configuration is expected to result in a reactor trip, as a typical Westinghouse 4-loop PWR design has a maximum step load decrease of around 50% of the plant rated load (40% steam dump capacity + 10% Reactor Control System compensation). Evaluation of plant response to a load rejection event, among other transient scenarios, would be required on a site-specific basis.

6.2. EQUIPMENT ASSESSMENT

Evaluation of the HP/LP turbines and MSRs for 30% and 50% extraction showed performance to be similar to the 75% and 50% power cases, respectively. While not explicitly performed here, it is expected that this equipment will perform similarly to a 25% power case. However, OEM review will be needed to verify whether equipment is designed to perform long-term operation at or near 25% power.

Detailed assessment of the condenser and power train pumps is also not a focus for 70% TPE, since the impacts observed under 30% and 50% TPE were relatively minor compared to the other equipment evaluated. Major replacement of these components is not expected for 70%, but site-specific evaluation will be necessary since individual plants may have different conditions from the generic plant.

The following subsections assess the feedwater heaters, extraction steam lines, and heater drain system – the systems with the most significant impacts under 30% and 50% – for 70% TPE.

6.2.1. Feedwater Heaters

The CD and FW systems deliver feedwater (condensed steam) to the steam generators. The CD system first directs flow through three parallel strings of low-pressure feedwater heaters (1st point external drain cooler and 1st through 4th point heaters). Flow then passes through two parallel strings of low-pressure feedwater heaters (5th point external drain cooler, 5th and 6th point heaters) to the TDFPs. FW flow then continues through two parallel high pressure feedwater heaters (7th point heaters) to the steam generators. The feedwater heaters receive extraction steam flow and moisture separator reheater drain flow from the turbine system.

The feedwater heaters are evaluated for the 70% TPE scenario below.

6.2.1.1. Nozzle and Tube Velocities

Table 6-2 provides feedwater heater channel end nozzle velocities for the 70% TPE cases.

Table 6-2. Condensate/Feedwater Heater Nozzle Velocities

FW Heater	Velocity (ft/s)			Δ (70%)
	HEI Limit	0%	70%	
1 st EDC	10	11.9	12.5	5.0%
1 st Point	10	11.9	12.5	5.0%
2 nd Point	10	11.9	12.5	5.0%
3 rd Point	10	11.9	12.5	5.0%
4 th Point	10	11.9	12.5	5.0%
5 th EDC	10	10.0	10.5	5.0%
5 th Point	10	9.6	8.6	-10.7%
6 th Point	10	9.6	8.6	-10.7%
7 th Point Inlet	10	10.2	9.1	-10.7%
7 th Point Outlet	10	15.8	14.1	-10.7%

Tube side nozzle velocities exceed the HEI guidelines for several of the FWHs and drain coolers; however, changes from the baseline case are small or decrease. As a result, feedwater nozzle wear is not expected to be an issue.

Table 6-3 provides the FWH tube velocities based on the density at average tube temperature.

Table 6-3. FWH Tube Velocities

FW Heater	Velocity (ft/s)			Δ (70%)
	HEI Limit	0%	70%	
1st EDC	10	10.7	11.2	4.3%
1st Point	10	8.9	9.3	3.8%
2nd Point	10	9.1	9.4	2.9%
3rd Point	10	9.6	9.8	2.0%
4th Point	10	8.1	8.2	1.2%
5th EDC	10	7.0	7.0	0.6%
5th Point	10	9.1	7.8	-14.8%
6th Point	10	8.5	7.2	-15.3%
7th Point	10	8.8	7.4	-16.0%

Tube velocities remain below or slightly exceed the HEI guidelines for the 70% TPE case. Because changes are small, it is not expected that this will impact FWH and drain cooler tube degradation.

Table 6-4 and Table 6-5 provide the FWH steam inlet and drain outlet nozzle velocities, respectively.

Table 6-4. Steam Inlet Nozzle Velocity

FW Heater	Velocity (ft/s)			Δ (70%)
	HEI Limit	0%	70%	
1st Point	215	137	197	43.9%
2nd Point	195	148	387	161.5%
3rd Point	179	179	614	243.1%
4th Point	167	156	466	199.4%
5th Point	156	101	283	179.8%
6th Point	150	103	210	103.8%
7th Point	146	80	111	38.5%

Table 6-5. Drain Outlet Nozzle Velocity

FW Heater	Velocity (ft/s)			Δ (70%)
	HEI Limit	0%	70%	
1 st EDC	4.0	2.3	1.5	-33.8%
1 st Point	4.0	1.8	0.5	-71.1%
2 nd Point	4.0	2.9	2.3	-21.1%
3 rd Point	4.0	2.4	2.1	-11.6%
4 th Point	4.0	2.8	2.4	-13.9%
5 th EDC	4.0	1.8	1.1	-37.6%
5 th Point	4.0	2.5	1.5	-38.0%
6 th Point	4.0	2.7	1.6	-39.5%
7 th Point	4.0	2.2	1.2	-44.9%

For the 70% TPE scenario, steam inlet nozzle velocities for the TPE case increase for all FWHs and exceed the HEI guideline for the 2nd, 3rd, 4th, 5th, and 6th point heaters, increasing by more than 100%. This will increase stress on the impingement plates for these heaters, and the structural integrity of these plates will need to be evaluated to determine if they can withstand these conditions. Shell wear rates will also likely increase, and it should be noted that changes to steam inlet velocity can affect the wear pattern of the shell. Shear stresses will also likely increase proportional to the velocities. Future inspections should be mindful of these changes. For FWHs inspected less than every outage, there is a high likelihood that inspection frequency will increase. However, a frequency greater than once per outage cycle is not expected. FAC evaluations should be performed to determine the operating impacts of these increased velocities.

Drain outlet velocities decrease for both TPE cases, so HEI guidelines are not challenged, and wear rates may decrease.

6.2.1.2. Tube Side Pressure Drop

The tube side pressure drop principally affects two design issues, (i) the differential pressure across the pass partition plate (PPP), and (ii) the total pressure drop in the feedwater train.

To review the impact on PPP pressure loss, the change in mass flow rate squared is shown in Table 6-6.

Table 6-6. Pass Partition Plate Pressure Loss

FW Heater	Mass Flow Rate (lbm/hr)		Ratio of Flow Rates, R (70% / 0%)		PPP dP
	0%	70%	R	R ²	
1 st EDC	3,778,163	3,966,967	105%	110%	10%
1 st Point	3,778,163	3,966,967	105%	110%	10%
2 nd Point	3,778,163	3,966,967	105%	110%	10%
3 rd Point	3,778,163	3,966,967	105%	110%	10%
4 th Point	3,778,163	3,966,967	105%	110%	10%
5 th EDC	5,667,245	5,950,450	105%	110%	10%
5 th Point	8,033,640	7,173,040	89%	80%	-20%
6 th Point	8,033,640	7,173,040	89%	80%	-20%
7 th Point	8,033,640	7,173,040	89%	80%	-20%

The pressure loss across the PPP is expected to increase in FWHeats 1 through 4 and both external drain coolers. However, the expected increase in tube side pressure drop for the TPE case is not expected to appreciably impact reliable operation of the heaters.

6.2.1.3. Drain Inlet Nozzle Mass Flux

The mass flux and mass flux parameter of flashing condensate flows entering the shell side of the FWHeats are provided in Table 6-7 for the 70% TPE scenario.

Table 6-7. Heater Drain Inlet Nozzle Mass Flux and Mass Flux Parameter for 70% Thermal Power Extraction

FW Heater	Mass Flux (lbm/s/ft ²)				Mass Flux Parameter (lbm/ft/s ²)			
	HEI Limit	0%	70%	Δ (70%)	HEI Limit	0%	70%	Δ (70%)
1 st EDC	250	141	94	-33.5%	4,000	4,755	4,947	4.0%
2 nd Point	250	148	135	-9.1%	4,000	6,491	6,780	4.5%
3 rd Point	250	179	160	-10.8%	4,000	4,141	6,333	52.9%
5 th EDC	250	102	66	-34.9%	4,000	199	77	-59.6%
5 th Point (cascading)	250	188	120	-36.3%	4,000	647	249	-61.5%
5 th Point (MSR)	250	119	34	-71.2%	4,000	4409	828	-81.2%
6 th Point	250	118	69	-41.3%	4,000	515	149	-71.1%
7 th Point	250	112	74	-34.2%	4,000	2,177	4,005	84.0%

For the 70% TPE case, drain inlet mass fluxes all decrease and remain below HEI guidelines. Conversely, the 1st point EDC, and 2nd, 3rd, and 7th point heaters exceed the guidelines. The increases on the 3rd and 7th point heaters are particularly pronounced (more than 50% increase each) due to the change in density from the lower shell pressure. If the subject station does not show sufficient margin to allow for this increase, additional flashing steam could increase drain inlet wear rates. Future inspections should be mindful for changes.

6.2.1.4. Operating Pressure and Temperature

Shell side operating pressure and temperature is provided in Table 6-8. Tube side operating temperature is provided in Table 6-9.

Table 6-8. Shell Side Operating Pressures and Temperatures

FW Heater	Pressure (psia)			Temperature (°F)		
	0%	70%	Δ (70%)	0%	70%	Δ (70%)
1 st EDC	5.4	1.2	-77.0%	165.6	109.2	-56.4°F
1 st Point	5.4	1.2	-77.0%	165.6	109.2	-56.4°F
2 nd Point	15.9	3.7	-76.6%	215.9	150.0	-65.9°F
3 rd Point	40.6	10.5	-74.0%	268.1	195.7	-72.4°F
4 th Point	89.5	27.4	-69.4%	319.9	245.2	-74.7°F
5 th EDC	186.1	64.0	-65.6%	375.8	297.0	-78.8°F
5 th Point	186.1	64.0	-65.6%	375.8	297.0	-78.8°F
6 th Point	287.1	105.3	-63.3%	413.3	331.6	-81.8°F
7 th Point	408.7	148.7	-63.6%	446.7	357.7	-89.0°F

Table 6-9. Tube Side Operating Temperatures

FW Heater	Temperature (°F)		Δ (70%)
	0%	70%	
1 st EDC	126.6	94.5	-31.8°F
1 st Point	161.7	107.1	-54.0°F
2 nd Point	212.8	139.4	-70.7°F
3 rd Point	265.0	189.0	-74.1°F
4 th Point	316.4	237.1	-77.2°F
5 th EDC	332.2	248.4	-83.0°F
5 th Point	370.2	291.0	-78.9°F
6 th Point	409.7	328.2	-81.3°F
7 th Point	441.5	353.5	-86.7°F

Operating temperatures and pressures decrease for all FWHs, therefore margins with design values will improve for the TPE case.

6.2.1.5. Drain Cooler Tube Vibration

Tube vibration in the 1st through 7th point heater drain coolers is evaluated by comparing the drain cooler volumetric flow rates. Results are provided in Table 6-10 below.

Table 6-10. Drain Cooler Vibration

FW Heater	Drain Volumetric Flow Rate (gpm)		Δ (70%)
	0%	70%	
1 st EDC	1,671	1,105	-33.8%
2 nd Point	1,240	978	-21.1%
3 rd Point	842	744	-11.6%
4 th Point	439	378	-13.9%
5 th EDC	3,767	2,349	-37.6%
6 th Point	2,434	1,472	-39.5%
7 th Point	1,578	870	-44.9%

The volumetric flow through all drain coolers is expected to decrease during operation, resulting in increased margin for tube vibration parameters.

6.2.1.6. Feedwater Heater Assessment Summary

Tube and tube side nozzle velocities exceed the HEI guidelines for several of the FWHs and drain coolers, but changes from the baseline case are small or decrease, therefore it is not expected that flashing, tube degradation, or nozzle wear will be an issue. Steam inlet nozzle velocities exceed HEI guidelines for the 2nd, 3rd, 4th, 5th, and 6th point heaters. This may cause over-stressing of the impingement plates, and shell wear rates will likely increase. FAC evaluations should be performed to determine the operating impacts of these increased velocities. Drain outlet velocities decrease for the 70% thermal extraction case, so HEI guidelines are not challenged, and wear rates may decrease.

Tube side pressure drop for the TPE case is not expected to appreciably impact heater reliability. Drain inlet mass fluxes remain below HEI guidelines, but the mass flux parameters for various heaters exceed the guidelines. This is an additional indicator that the impingement plates are at risk for structural damage under 70% TPE conditions.

Operating temperatures and pressures decrease for all FWHs, therefore design margins will improve for the TPE case. Volumetric flow through all drain coolers is also expected to decrease during TPE operation, resulting in increased margin for tube vibration parameters.

Detailed, site-specific evaluation would be required in order to assess the severity these velocity-induced issues and the potential for full or partial heater replacement.

A detailed evaluation of the feedwater heaters is provided in Attachment P.

6.2.2. Extraction Steam

The ES system diverts steam taken from the turbine to the feedwater heaters. There are three stages of extraction from the HPT and four stages of extraction from each LPT. The Extraction Steam is used to heat the feedwater in seven separate feedwater heater stages.

There are three trains for the 1st through 4th point LP feedwater heaters, two trains for the 5th and 6th point LP feedwater heaters, and two trains for the 7th point HP feedwater heater.

Heat balance data for the 70% TPE scenario is discussed below.

6.2.2.1. Pressure Drop

Table 6-11 shows the pressure drop in the ES lines.

Table 6-11. Extraction Steam Line Pressure Drop

Description	Upstream Pressure (psia)			Pressure Drop (psid)		
	0%	70%	Δ (70%)	0%	70%	Δ (70%)
HPT to 7th Stg FWH	451.0	176.0	-61.0%	6.50	4.33	-33.4%
HPT to 6th Stg FWH	296.5	108.8	-63.3%	8.46	12.42	46.8%
HPT to 5th Stg FWH	190.3	65.5	-65.6%	4.97	13.32	168.1%
LPT to 4th Stg FWH	92.39	28.39	-69.3%	4.33	11.53	166.3%
LPT to 3rd Stg FWH	41.9	10.93	-73.9%	3.24	10.21	214.6%
LPT to 2nd Stg FWH	16.43	3.88	-76.4%	0.78	1.19	52.5%
LPT to 1st Stg FWH	5.428	1.259	-76.8%	0.13	0.06	-58.0%

The pressure drop in the lines from the HPT to 7th stage FWHs and LPTs to 1st stage FWHs decreases, but all other extraction steam lines see an increase in pressure drop for the 70% TPE case due to higher flow velocities. The most significant changes are in lines to the 3rd, 4th, and 5th stage FWHs, which have an increase in pressure drop of greater than 150%.

6.2.2.2. Operating Conditions

ES line pressures and temperatures are compared below in Table 6-12.

Table 6-12. Extraction Steam Line Operating Conditions

Description	Line Pressure (psia)			Line Temperature (°F)		
	0%	70%	Δ (70%)	0%	70%	Δ (70%)
HPT to 1st Stg Rhtr	448.7	256.2	-42.9%	456.5	371.2	-85.3°F
HPT to 7th Stg FWH	408.7	224.5	-45.1%	456.5	371.2	-85.3°F
HPT to 6th Stg FWH	287.1	157.5	-45.1%	416.3	334.0	-82.3°F
HPT to 5th Stg FWH	186.1	95.5	-48.7%	377.6	298.5	-79.2°F
LPT to 4th Stg FWH	89.6	44.8	-50.0%	382.5	383.2	0.6°F
LPT to 3rd Stg FWH	40.6	19.4	-52.3%	270.1	223.4	-46.7°F
LPT to 2nd Stg FWH	15.9	7.3	-54.0%	217.7	151.7	-66.0°F
LPT to 1st Stg FWH	5.4	2.5	-54.5%	165.7	109.6	-56.2°F

Pressures and temperatures decrease or marginally increase for all ES lines under the 70% TPE case, therefore design margins will largely improve.

6.2.2.3. Expansion Joint Liner Thickness

Required liner thicknesses are compared in Table 6-13.

Table 6-13. Expansion Joint Liner Thickness

Description	Required Liner Thickness (in)		Δ (70%)
	0%	70%	
LPT to 4th Stg FWH	0.137	0.236	72.8%
LPT to 3rd Stg FWH	0.138	0.256	84.9%
LPT to 2nd Stg FWH	0.156	0.251	61.1%
LPT to 1st Stg FWH	0.149	0.178	19.6%

Liner thickness requirements increase for the 70% TPE case. Existing expansion joints will need to be evaluated on a plant-specific basis and may need to be replaced to ensure they meet required thicknesses.

6.2.2.4. Extraction Steam Assessment Summary

Analysis of the extraction steam system for the 70% TPE scenario shows that extraction steam line pressure drops increase in general due to higher flow velocities, with lines to the 3rd, 4th, and 5th stage feedwater heaters seeing significant increases of over 150%. Expansion joint liner thickness requirements also increase and will need to be evaluated on a plant-specific basis and may need to be replaced to ensure they meet these new requirements. Pressures and temperatures largely decrease during 70% TPE operation, which would improve operating margins.

Refer to Attachment Q for a detailed evaluation of the Extraction Steam system.

6.2.3. Heater Drain System

The FWH drain system design for 70% TPE is the same as the design for 30% TPE. This system is comprised of seven stages of feedwater heating for normal operations. System impacts under 70% TPE are assessed below.

6.2.3.1. Valve Flow Capacity

Valve volumetric flow is computed based on the mass flow rate and fluid temperature.

Table 6-14 compares volumetric flow for the baseline and 70% TPE scenarios.

Table 6-14. Drain Volumetric Flow Comparison

Description	Volumetric Flow Rate (gpm)		Δ (70%)
	0%	70%	
Flash Tank Normal	1,683	1,101	-34.6%
FWH 2 Normal	1,234	972	-21.3%
FWH 3 Normal	836	739	-11.5%
FWH 4 Normal	434	374	-13.9%
FWH 6 Normal	2,416	1,465	-39.4%
FWH 7 Normal	1,557	861	-44.7%
MSDT Normal	756	120	-84.1%
RHDT1 Normal	331	89	-73.1%
RHDT2 Normal	527	348	-34.1%
Flash Tank Emergency	1,683	1,101	-34.6%
FWH 2 Emergency	1,234	972	-21.3%
FWH 3 Emergency	836	739	-11.5%
FWH 4 Emergency	434	374	-13.9%
FWH 5 Emergency	3,890	2,415	-37.9%
FWH 6 Emergency	2,416	1,465	-39.4%
FWH 7 Emergency	1,557	861	-44.7%
MSDT Emergency	756	120	-84.1%
RHDT1 Emergency	331	89	-73.1%
RHDT2 Emergency	527	348	-34.1%

As shown above, all drains experience a decrease in flow.

6.2.3.2. Valve Pressure Drop

The pressure drop across the valve is the minimum of the allowable pressure drop due to choked flow and the available pressure drop from valve inlet to outlet based on flow conditions and frictional losses. Pressure loss is computed in Table 6-15.

Table 6-15. Drain Valve Pressure Loss for 70% Thermal Power Extraction

Description	Pressure Drop (psid)				Δ (70%)	
	0%		70%		Choked	Available
	Choked	Available	Choked	Available		
Flash Tank Normal	2.7	7.3	3.4	5.1	28.1%	-30.3%
FWH 2 Normal	2.3	3.2	-1.6	-2.4	-167.2%	-174.2%
FWH 3 Normal	9.1	14.6	-1.5	-2.1	-116.9%	-114.3%
FWH 4 Normal	32.1	44.5	10.7	13.7	-66.8%	-69.1%
FWH 6 Normal	85.0	95.9	33.1	37.0	-61.1%	-61.4%
FWH 7 Normal	90.9	108.1	28.8	30.4	-68.3%	-71.9%
MSDT Normal	19.6	5.9	9.4	7.4	-52.2%	26.7%
RHDT1 Normal	42.7	249.3	10.4	102.5	-75.7%	-58.9%
RHDT2 Normal	115.6	454.6	118.8	729.7	2.8%	60.5%
Flash Tank Emergency	4.1	9.2	4.0	5.9	-1.2%	-35.7%
FWH 2 Emergency	5.5	11.7	1.7	2.7	-69.3%	-76.8%
FWH 3 Emergency	15.0	37.1	4.6	9.2	-69.4%	-75.1%
FWH 4 Emergency	38.4	92.0	17.3	32.3	-54.9%	-64.9%
FWH 5 Emergency	23.0	196.4	13.0	76.0	-43.4%	-61.3%
FWH 6 Emergency	86.9	283.3	35.1	103.1	-59.6%	-63.6%
FWH 7 Emergency	97.5	405.9	35.8	147.4	-63.3%	-63.7%
MSDT Emergency	16.4	186.0	5.9	65.8	-64.0%	-64.6%
RHDT1 Emergency	47.6	444.7	15.2	175.3	-68.2%	-60.6%
RHDT2 Emergency	116.8	862.6	120.6	880.1	3.3%	2.0%

All drain control valves experience choked flow conditions except for the moisture separator drain tank, and FWH 2 and 3 normal DCVs. The FWH 2 and 3 normal drain control valve exhibits excessive inlet and outlet pressure drop resulting in a negative pressure loss, which is not possible. Adjustments to plant operations would be required in order to maintain normal operation under 70% TPE. This could include opening of the emergency dump valves or opening of the LP FWH bypass, as is shown in Attachment O for the 50% TPE cases.

6.2.3.3. Required Valve C_v

Required valve C_v values are shown in Table 6-16Table 5-26.

Table 6-16. Drain Valve Required C_v Capacity

Description	C _v		Δ (70%)
	0%	70%	
Flash Tank Normal	1019	594	-41.7%
FWH 2 Normal	796	N/A	N/A
FWH 3 Normal	271	N/A	N/A
FWH 4 Normal	74	112	51.9%
FWH 6 Normal	245	245	-0.3%
FWH 7 Normal	150	152	1.3%
MSDT Normal	292	42	-85.5%
RHDT1 Normal	46	26	-43.6%
RHDT2 Normal	43	28	-35.0%
Flash Tank Emergency	823	546	-33.6%
FWH 2 Emergency	520	744	43.3%
FWH 3 Emergency	211	341	62.0%
FWH 4 Emergency	68	88	30.5%
FWH 5 Emergency	759	642	-15.4%
FWH 6 Emergency	243	237	-2.1%
FWH 7 Emergency	145	136	-5.9%
MSDT Emergency	175	48	-72.8%
RHDT1 Emergency	43	21	-50.7%
RHDT2 Emergency	43	28	-35.2%

For the 70% TPE case, the required C_v capacity for FWHs 2, 3, and 4 emergency DCVs and the FWH 4 normal DCV increase significantly, and would require station specific review for valve acceptability. The FWH 2 and 3 normal DCV cannot meet the flow capacity requirements of 70% TPE and would require operational and/or design changes in order to satisfy system requirements (see Attachment O for potential workarounds under 50% TPE). This would need to be determined based on the plant specific evaluation. Flash tank and the various MSR drain tanks all see reduced capacity requirements and remain acceptable.

6.2.3.4. Drain Tank Parameters

The operating parameters for the MSDT, RH1DT, RH2DT, and Flash Tank are reviewed in Table 6-17.

Table 6-17. Drain Tank Conditions

Parameter	Units	0%	70%	Δ (70%)
MSDT Drain Flow	lbm/hr	331,167	55,451	-83.3%
RH1DT Drain Flow	lbm/hr	135,811	39,071	-71.2%
RH2DT Drain Flow	lbm/hr	200,488	131,857	-34.2%
Flash Tank Drain Flow	lbm/hr	821,877	546,517	-33.5%
MSDT Drain Pressure	psia	184.6	63.5	-65.6%
RH1DT Drain Pressure	psia	444.2	173.4	-61.0%
RH2DT Drain Pressure	psia	864.2	877.9	1.6%
Flash Tank Drain Pressure	psia	5.42	1.25	-76.9%
MSDT Drain Temperature	°F	375.1	296.4	-78.7°F
RH1DT Drain Temperature	°F	455.0	370.0	-85.0°F
RH2DT Drain Temperature	°F	527.2	529.0	1.9°F
Flash Tank Drain Temperature	°F	165.2	108.8	-56.4°F

Mass flow rates decrease for all drain tanks. Pressure and temperatures also decrease for all tanks except the 2nd stage reheater drain tank, which marginally increases. As a result, the heater drain system drain tanks are expected to operate normally during thermal power extraction operation.

6.2.3.5. Heater Drain Assessment Summary

The required C_v capacity for all the flash tank and the various MSR drain tanks DCVs show reduced capacity requirements when operating with 70% TPE. FWH 2, 3, and 4 emergency DCVs and the FWH 4 normal DCV requirements increase significantly (>30%), and it is expected that a station specific review of these FWHs would require valve/trim replacement prior to operation with thermal power extracted. The normal DCVs for FWHs 2 and 3 cannot meet the flow capacity requirements of 70% thermal extraction and would require operational and/or design changes in order to satisfy system requirements. This would need to be determined based on the plant specific evaluation.

Operating parameters for all heater drain system drain tanks either decrease or show minimal change and are expected to operate normally during thermal power extraction operation.

A detailed evaluation of the Heater Drain system is provided in Attachment R.

7. CONCLUSIONS

This report develops a detailed PEPSE heat balance model for a generic nuclear power plant and evaluates the impacts of 30%, 50%, and 70% thermal power extraction (TPE) on the nuclear plant. Plant transients, hazards, and core reactivity impacts are assessed. New steam extraction lines would be included under station HELB programs. Reactor response to load rejection or other transient events would need to be assessed for acceptability through further core and plant response analysis. Following development of the PEPSE model, major equipment was analyzed to assess margin, maintenance, and replacement impacts under these TPE scenarios.

Table 7-1 below summarizes the PEPSE results for the four (4) extraction scenarios evaluated: (1) 30% TPE, (2) 50% TPE, (3) 50% TPE with 20% condensate bypass of the low-pressure (LP) feedwater heaters (FWHs), and (4) 70% TPE.

Table 7-1. General Impacts for Thermal Power Extraction Scenarios

Description	Units	Baseline 0%	Case 1 30%	Case 2 50%	Case 3 50% w/ Bypass	Case 4 70%
Generator Electric Power	MWe	1,228.0	844.6	585.3	573.1	327.3
Thermal Power Extracted	MWt	0	1,095	1,827	1,826	2,557
% of Flow - MS	%	0	21.9	37.6	37.7	55.0
MS Flow from SGs	lbm/hr	16,037,390	15,436,290	14,952,560	14,916,170	14,316,180
HP Turbine Inlet Flow	lbm/hr	15,218,400	11,272,260	8,615,524	8,619,505	5,893,152
HP Turbine First Stage Pressure	psia	651.5	487.5	374.8	375.2	260.4
MSR Inlet Pressure	psia	190.3	140.2	104.6	97.6	65.5
LP Turbine Inlet Flow	lbm/hr	3,673,069	2,677,248	1,980,267	1,845,837	1,230,440
LP Turbine Inlet Pressure	psia	175.5	129.3	96.43	90.04	60.4
Condenser Duty	BTU/hr	8.21E+09	5.78E+09	4.18E+09	4.22E+09	2.57E+09
Condensate Pump Flow	lbm/hr	11,334,490	11,723,820	11,889,450	11,475,500	11,900,900
Heater Drain Pump Flow	lbm/hr	4,732,792	3,742,365	3,093,006	3,470,571	2,445,181
Feedwater Pump Flow	lbm/hr	16,067,280	15,466,190	14,982,480	14,946,080	14,346,080
Final Feedwater Temperature	°F	440.9	413.3	389.0	387.1	354.0
Cascading drain Flow to Condenser	lbm/hr	817,619	745,815	670,424	522,171	542,768
Reboiler Inlet Mass Flow	lbm/hr	-	3,376,114	5,629,289	5,628,542	7,878,196

Figure 7-1 illustrates the different locations thermal power is sent under baseline (0% TPD) and extraction scenarios. With increasing extraction, less thermal power is discharged to the condenser. This will result in reduced circulating water demand, while more power is delivered to off-site users for thermal applications.

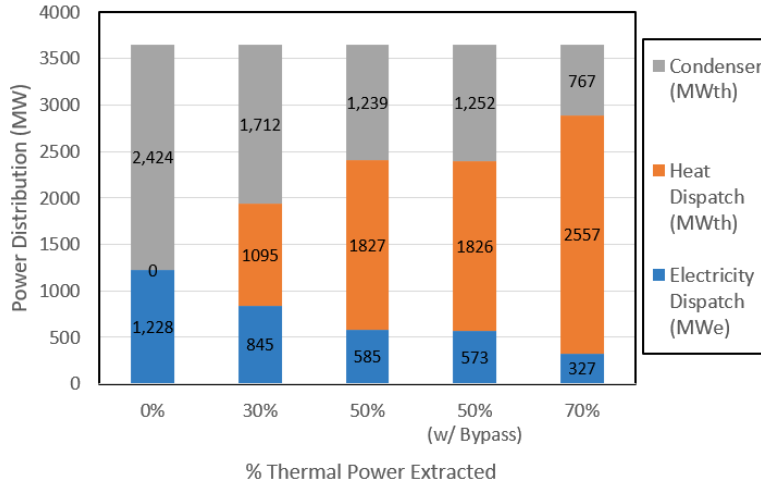

Figure 7-1. Thermal Power Destinations for Thermal Power Extraction Scenarios

7.1. 30% EXTRACTION

Under the 30% TPE scenario, high-pressure(HP)/low-pressure(LP) turbine and moisture separator reheater (MSR) performance is very similar to the performance under a 75% power case; this operating profile is expected to be maintainable for long durations.

Condenser operating conditions are expected to continue to meet operation requirements while evacuation capacity will not be impacted.

There are minimal impacts on the power train pumps and replacement is not anticipated.

It is not expected that feedwater heater tube degradation or nozzle wear will be an issue, although heater shell wear patterns could be affected, resulting in increased degradation. Tube side pressure drop for the TPE case is not expected to appreciably impact reliable operation of the heaters. Drain inlet mass fluxes remain bounded by industry guidance. However, mass flux parameters for specific heaters were shown to exceed guidelines and could result in increased wear rates. Operating temperatures and pressures decreased for all feedwater heaters, increasing design margin. Volumetric flow through all drain coolers is also expected to decrease, resulting in increased margin for tube vibration parameters.

Analysis of the extraction steam system shows that overall, extraction steam line pressure drops increase due to higher flow velocities. The increased flow velocities should be included in the individual station Flow Accelerated Corrosion (FAC) program to ensure that any potential degradation is properly monitored and addressed. Expansion joint liner thickness requirements also increased. Replacement of expansion joints may be needed to ensure requirements are met with TPE conditions. As a result of pressure and temperature decreases with 30% TPE operating condition margins largely improved in the extraction steam system.

Heater drain tanks are expected to operate normally. Feedwater heater (FWH) drain control valves (DCVs) will require greater flow passing capability. Therefore, station specific review is required. It is expected that station specific review will find replacement of the FWH 2 and 3 DCVs necessary due to significant increase in required valve C_v when operating with 30% TPE.

Impact on material degradation, material properties, and fatigue under the 30% TPE scenario is expected to be limited to specific locations and conditions as reflected in this report. Most components are exposed to reduced temperatures, pressures, and flows and those components would not be negatively affected by increasing TPE to 30%. No temperature or pressure related impacts on materials were noted in the evaluation data which would be expected to impact material properties or increase the risk fatigue related issues. Equipment that receives the feedwater (i.e., steam generator) from the Feedwater Heaters will receive water at a lower temperature, however this temperature reduction (27.6°F lower) does not result in a significant impact on the material properties of this equipment. Impact of thermal cycling due to changes in plant operations and level of TPE would be expected to be minimal due to the small temperature delta from normal operations.

7.2. 50% EXTRACTION

Under the 50% TPE scenario HP/LP turbine and MSR performance is similar to the performance under a 50% power case and is expected to be a maintainable operating profile. Nevertheless, OEM review should be performed to verify acceptability. There are minimal impacts to condenser operating conditions and power train pumps, therefore no changes are expected to this equipment.

FWH replacement is not expected, but careful inspection is necessary. FWH and drain cooler tube and nozzle velocity increases are small, but may impact shell wear patterns which could lead to increased degradation. FWH nozzle inlet velocity increases are more pronounced, therefore FAC program impacts should be evaluated for potential increases in wear rate and inspection frequency. Tube side pressure drop and drain inlet mass fluxes face minor impacts, while the mass flux parameters for various heaters exceed guidance with no LP FWH bypass; partial LP FWH bypass resolves this issue. Operating condition (temperature, pressure, and tube vibration) margins also improve for all FWHs.

Analysis of the extraction steam system shows extraction steam line pressure drops increase due to velocity increases. Expansion joint liner thickness requirements also increase, while operating conditions improved. Existing expansion joints would need to be evaluated on a plant-specific basis and may require replacement.

Heater drain tanks are expected to operate normally under 50% TPE. However, with no LP FWH bypass, normal FWH 2 drains are incapable of passing the required flow and multiple FWH DCVs may require greater flow passing capability through either replacement or emergency dump to the condenser. Station specific review of the FWH 2 and 3 DCVs, and potentially the FWH 4 DCVs, is expected to require replacement for these valves if operating without bypass. Conversely, with the implementation of partial LP FWH bypass, the increase in required flow capacity is significantly reduced and valve replacement is not expected to be required. The tradeoff is a small (~12 MW_e) decrease in electric power generation. These scenarios should be evaluated in more detail on a site-specific basis in order to assess which is the preferred option. Additionally, other options may be explored to decrease pressure drop such as drain line resizing.

The impacts for 50% TPE are amplified compared to those for 30% TPE. The impact on material degradation, material properties, and fatigue was found to be greater on the FWHs, extraction steam, and FWH drain control valves. Equipment that receives the feedwater (i.e., steam generator) from the Feedwater Heaters under the

50% extraction scenarios will receive water at a lower temperature; however, this temperature reduction (51.9°F to 53.8°F lower) would not be expected to result in a large negative impact on the material properties of this equipment. As with the 30% evaluation, the impact of thermal cycling due to changes in plant operations and level of TPE would be expected to be minor due to the temperature delta from normal operations. The areas which could exhibit increases in flow related wear at 50% extraction should also be subject to increased inspections and inclusion of the site specific FAC programs.

7.3. 70% EXTRACTION

Evaluation of the HP/LP turbines and MSRs for 30% and 50% extraction showed performance to be similar to the 75% and 50% power cases, respectively. While not explicitly performed here, it is expected that this equipment will perform similarly to a 25% power case. Nevertheless, OEM review would be necessary.

Detailed assessment of the condenser and power train pumps is also not a focus for 70% TPE, since the impacts under 30% and 50% TPE were relatively minor compared to the other equipment evaluated. Major replacement of these components is not expected, but evaluation will be required on a site-specific basis.

FWH and drain cooler tube and nozzle velocity increases are relatively minor but may impact shell wear patterns. Steam inlet nozzle velocities exceed HEI guidelines for the 2nd, 3rd, 4th, 5th, and 6th point heaters, and drain inlet mass flux parameters for various heaters exceed the guidelines. Both of these impacts indicate potential over-stressing of the impingement plates. FAC evaluation would additionally be required to determine the extent of impacts to shell wear rates. This is an additional indicator that the impingement plates are at risk for structural damage under 70% TPE conditions. Operating condition (temperature, pressure, and tube vibration) margins improve for all FWHs. Nevertheless, formal site-specific evaluation would be required to assess whether FWH replacement is needed due to increased flow velocities.

Analysis of the extraction steam system shows extraction steam line pressure drops increase due to greater velocities, with lines to the 3rd, 4th, and 5th stage feedwater heaters seeing increases of over 150%. Expansion joint liner thickness requirements also increase, while operating conditions largely improved. Existing expansion joints would need to be evaluated on a plant-specific basis and may require replacement.

The Heater Drain system experiences a reduced flow under the 70% extraction scenario and is expected to operate normally under 70% TPE. However, normal FWH 2 and 3 drains are incapable of passing the required flow and multiple FWH DCVs may require greater flow passing capability through either replacement or emergency dump to the condenser. Station specific review of the FWH 2, 3, and 4 emergency DCVs and the FWH 4 normal DCV would be needed, along with operational changes to address the C_v limitations of the FWH 2 and 3 normal DCVs.

At 70% extraction, some impacts noted under the 30% and 50% extraction scenarios are increased and some decreased. The impact on material degradation, material properties, and fatigue were found to be greater in most cases. The equipment receiving feedwater (i.e., steam generator) from the FWHs under the 70% TPE scenario will receive water at a temperature well below (86.9°F lower) the baseline (0% TPE) scenario. This temperature delta is not expected to result in a large impact on the equipment material properties but should be evaluated for station extraction specific conditions. The impact of thermal cycling due to changes in plant operations and level of thermal extraction would be expected to be acceptable based on temperature and pressure deltas from normal operations.

7.4. SUMMARY OF IMPACTS

The conclusions above establish that 30% TPE can be performed safely without major equipment replacement. Minor upgrades and increased maintenance may be required for specific components (e.g., expansion joints and DCVs). These same conclusions generally hold true for the equipment evaluated at 50% TPE, although additional evaluations, equipment upgrades, and/or replacements may be required, specifically for the FWHs, extraction steam lines, and FWH DCVs which experience larger impacts. Operator action through partial LP FWH bypass or emergency drains dump can reduce some of these impacts and should be assessed on a site-specific basis to ensure these components can continuously perform these functions without impacting the safe operation of plants. Plants should also consider the potential for power uprates to account for the change in equipment operating conditions if permanently operating under a TPE profile.

Investigation of the items of concern for 70% shows that going above 50% TPE will prove challenging on plant systems – both on the balance of plant side as well as potential Nuclear Steam Supply System (NSSS) impacts – and is not expected to be cost effective option for the existing US nuclear fleet. Nevertheless, the extraction of up to 50% thermal power remains a feasible option for these plants.

The results described herein are based on a generic reference plant and PEPSE model, therefore the conclusions of site-specific evaluation may differ from this generic PEPSE model analysis and equipment assessment based on plant/equipment design, operation, and age. Detailed evaluation of the NSSS impacts was also not performed. Plant specific evaluation of core/plant response and equipment would be required for any station considering a modification of this types described in this study.

8. REFERENCES

1. SL-016181 Rev. 1, "Nuclear Power Plant Pre-Conceptual Design Support for Large-Scale Hydrogen Production Facility", November 2022.
2. PEPSE V84 Computer software, (S&L program # 03.7.551-84.0).
3. STMFUNC, "Steam Table Function Dynamic Link Library", S&L Program Number 03.7.598-2.0.
4. AFT Fathom™, Version 11.0, "Computer Software for Modeling Incompressible Flow in Pipe Networks," S&L Program No. 03.7.721-11.0.
5. ANSI/HI 9.6.3-1997, "American National Standard for Centrifugal/Vertical Pumps – Allowable Operating Region", Hydraulic Institute, Parsippany, NJ.
6. ANSI/HI 9.6.1-1998, "American National Standard for Centrifugal and Vertical Pumps for NPSH Margin", Hydraulic Institute, Parsippany, NJ.
7. Standards for Closed Feedwater Heaters. Heat Exchange Institute, Inc. Sixth Edition, 1998.
8. Standards of the Tubular Exchanger Manufacturers Association, Tubular Exchanger Manufacturers Association, Inc. Seventh Edition, 1988.
9. Standards of the Expansion Joint Manufacturers Association (EJMA), Inc., Ninth Edition, 2008.
10. Crane Technical Paper No. 410, Flow of Fluids Through Valves, Fittings, and Pipe, 1991.
11. BHMN-Valve-Sizing-Handbook-TS-19540C-0222, "Masoneilan Control Valve Sizing Handbook," Baker Hughes, 02/2022.
12. Department of Energy, "3 Nuclear Power Plants Gearing Up for Clean Hydrogen Production", <https://www.energy.gov/ne/articles/3-nuclear-power-plants-gearing-clean-hydrogen-production>, November 2022.

9. ATTACHMENTS

Attachment A: PEPSE Modeling	37 pages
Attachment B: HP and LP Turbine Assessment – 30% TPE	10 pages
Attachment C: Condenser Evaluation – 30% TPE	4 pages
Attachment D: Power Train Pumps Evaluation – 30% TPE	11 pages
Attachment E: Moisture Separator Reheater Evaluation – 30% TPE	3 pages
Attachment F: Feedwater Heater Evaluation – 30% TPE	14 pages
Attachment G: Extraction Steam Evaluation – 30% TPE	9 pages
Attachment H: Heater Drain System Assessment – 30% TPE	11 pages
Attachment I: HP and LP Turbine Assessment – 50% TPE	12 pages
Attachment J: Condenser Evaluation – 50% TPE	4 pages
Attachment K: Power Train Pumps Evaluation – 50% TPE	11 pages
Attachment L: Moisture Separator Reheater Evaluation – 50% TPE	3 pages
Attachment M: Feedwater Heater Evaluation – 50% TPE	15 pages
Attachment N: Extraction Steam Evaluation – 50% TPE	10 pages
Attachment O: Heater Drain System Assessment – 50% TPE	13 pages
Attachment P: Feedwater Heater Evaluation – 70% TPE	14 pages
Attachment Q: Extraction Steam Evaluation – 70% TPE.....	9 pages
Attachment R: Heater Drain System Assessment – 70% TPE.....	11 pages

Attachment A
PEPSE Modeling for 30%, 50%, and 70% Extraction

**Attachment A – PEPSE Modeling for 30%, 50%, and 70%
Extraction**

Prepared: Gabriel Neimark

Reviewed: Nic Richards

Attachment A
PEPSE Modeling for 30%, 50%, and 70% Extraction

A1 **Purpose**

The purpose of this attachment is to evaluate the impact of extracting steam from the nuclear power cycle main steam system to supply thermal energy to the plant boundary for off-site use. The steam is condensed in a reboiler unit and returned to the nuclear power cycle. The thermal energy used by the reboiler unit is used to boil water to steam which is then directly supplied to the plant boundary. The main purpose of this attachment is to evaluate the impact on plant systems for scenarios with 30%, 50%, and 70% extraction of thermal energy from the main power cycle.

A2 **Methodology**

A generic station PEPSE model is used as the starting point of this evaluation. The generic station is a representative 4 Loop Westinghouse PWR with a targeted generator output of ~1225 MWe.

The generic PEPSE model is modified by adding splitters, mixers, and stream components to allow extraction from main steam and return to the main condenser.

A heat exchanger component is used to model the steam reboiler thermal performance. The extracted steam is condensed and subcooled before it is returned to the main power cycle.

A pump component is used to model system pressure increase from a demineralized water supply tank supplying water to the reboiler, which boils this water to steam (which is then supplied to the plant boundary). The amount of thermal energy extracted is calculated within PEPSE using operational variables. The amount of thermal energy extracted is controlled by changing the flow fraction out of the main steam splitter supplying the reboiler.

A3 **Assumptions**

- A3.1 The temperature of the condensed and subcooled extraction steam is assumed to be 120°F before it is returned to condenser.
- A3.2 The discharge pressure for the cogen water supply pump is assumed to be 650 psia.
- A3.3 The cogen heat exchanger pressure drop is assumed to be 50 psid.
- A3.4 Pressure and temperature losses to the environment are included in the new associated stream components based on the assumed inputs in the following table.

Description	Units	30%	50%/70%
Main Steam Extraction DP	psid	80	80
Main Steam Extraction Heat Loss	BTU/hr	210,000	250,000
Process Steam Extraction DP	psid	100	100
Process Steam Extraction Heat Loss	BTU/hr	2,230,000	2,700,000

Attachment A
PEPSE Modeling for 30%, 50%, and 70% Extraction

A4 References

A4.1 PEPSE V84 Computer software, S&L program # 03.7.551-84.0 (PEPSE is run on S&L PC PL13857)

A5 Results of 30% Thermal Extraction

The base PEPSE model is modified, as discussed in Section A2, to allow the targeted thermal extraction level to be achieved. The PEPSE diagrams (located at the end of the Attachment A) show the results considering 1) No thermal power extraction (i.e., no off-site use), and 2) 30% thermal power extraction. Tables A5.1-A5.7 compare important operating parameters within the nuclear power cycle to determine possible significant impact to station equipment.

Table A5.1: General Impacts – 30% Thermal Extraction

Description	Units	0%	30%	Δ (30%)
Generator Electric Power	MWe	1,228.0	844.6	-31.2%
Thermal Power Extracted	MWt	0	1,095	-
% of Flow - MS	%	0	21.9	-
MS Flow	lbm/hr	16,037,390	15,436,290	-4%
HP Turbine Inlet Flow	lbm/hr	15,218,400	11,272,260	-26%
HP Turbine First Stage Pressure	psia	651.5	487.5	-25%
MSR Inlet Pressure	psia	190.3	140.2	-26%
LP Turbine Inlet Flow	lbm/hr	3,673,069	2,677,248	-27%
LP Turbine Inlet Pressure	psia	175.5	129.3	-26%
Condenser Duty	BTU/hr	8.21E+09	5.78E+09	-30%
Condensate Pump Flow	lbm/hr	11,334,490	11,723,820	3%
Heater Drain Pump Flow	lbm/hr	4,732,792	3,742,365	-21%
Feedwater Pump Flow	lbm/hr	16,067,280	15,466,190	-4%
Final Feedwater Temperature	°F	440.9	413.3	-27.6°F
Cascading Drain Flow to Condenser	lbm/hr	817,619	745,815	-9%
Cogen HX Inlet Mass Flow	lbm/hr	-	3,376,114	-
Cogen HX Inlet Pressure	psia	-	817.3	-
Cogen HX Inlet Temperature	°F	-	520.7	-
Cogen HX Inlet Enthalpy	BTU/lbm	-	1,197.2	-
Cogen HX Outlet Temperature	°F	-	120.0	-
Cogen HX Outlet Enthalpy	BTU/lbm	-	90.1	-

Table A5.2: MSR Impacts – 30% Thermal Extraction

Description	Units	0%	30%	Δ (30%)
MSR A Removal Effectiveness	-	95.0%	95.0%	0.0%
MSR A Chevrons Inlet Flow	lbm/hr	3,151,396	2,266,680	-28.1%
MSR A Chevrons Inlet Enthalpy	BTU/lbm	1,104.0	1,115.3	1.0%

Attachment A
PEPSE Modeling for 30%, 50%, and 70% Extraction

Description	Units	0%	30%	Δ (30%)
MSR A Chevrons Inlet Pressure	psia	190.3	140.2	-26.3%
MSR A 1 st Stage Inlet Enthalpy	BTU/lbm	1,192.7	1,189.0	-0.3%
MSR A 1 st Stage Inlet Pressure	psia	184.6	136.0	-26.3%
MSR A 2 nd Stage Inlet Enthalpy	BTU/lbm	1,226.8	1,221.8	-0.4%
MSR A 2 nd Stage Inlet Pressure	psia	181.8	134.0	-26.3%
MSR B Removal Effectiveness	-	95.0%	95.0%	0.0%
MSR B Chevrons Inlet Flow	lbm/hr	3,151,396	2,266,680	-28.1%
MSR B Chevrons Inlet Enthalpy	BTU/lbm	1,104.0	1,115.3	1.0%
MSR B Chevrons Inlet Pressure	psia	190.3	140.2	-26.3%
MSR B 1 st Stage Inlet Enthalpy	BTU/lbm	1,192.7	1,189.0	-0.3%
MSR B 1 st Stage Inlet Pressure	psia	184.6	136.0	-26.3%
MSR B 2 nd Stage Inlet Enthalpy	BTU/lbm	1,226.8	1,221.8	-0.4%
MSR B 2 nd Stage Inlet Pressure	psia	181.8	134.0	-26.3%
MSR C Removal Effectiveness	-	95.0%	95.0%	0.0%
MSR C Chevrons Inlet Flow	lbm/hr	3,151,396	2,266,680	-28.1%
MSR C Chevrons Inlet Enthalpy	BTU/lbm	1,104.0	1,115.3	1.0%
MSR C Chevrons Inlet Pressure	psia	190.3	140.2	-26.3%
MSR C 1 st Stage Inlet Enthalpy	BTU/lbm	1,192.7	1,189.0	-0.3%
MSR C 1 st Stage Inlet Pressure	psia	184.6	136.0	-26.3%
MSR C 2 nd Stage Inlet Enthalpy	BTU/lbm	1,226.8	1,221.8	-0.4%
MSR C 2 nd Stage Inlet Pressure	psia	181.8	134.0	-26.3%
MSR D Removal Effectiveness	-	95.0%	95.0%	0.0%
MSR D Chevrons Inlet Flow	lbm/hr	3,151,396	2,266,680	-28.1%
MSR D Chevrons Inlet Enthalpy	BTU/lbm	1,104.0	1,115.3	1.0%
MSR D Chevrons Inlet Pressure	psia	190.3	140.2	-26.3%
MSR D 1 st Stage Inlet Enthalpy	BTU/lbm	1,192.7	1,189.0	-0.3%
MSR D 1 st Stage Inlet Pressure	psia	184.6	136.0	-26.3%
MSR D 2 nd Stage Inlet Enthalpy	BTU/lbm	1,226.8	1,221.8	-0.4%
MSR D 2 nd Stage Inlet Pressure	psia	181.8	134.0	-26.3%

Table A5.3: MSR Drain Impacts – 30% Thermal Extraction

Description	Units	0%	30%	Δ (30%)
MSDT A Drain Flow	lbm/hr	331,167	192,757	-41.8%
MSDT A Drain Enthalpy	BTU/lbm	348.4	322.6	-7.4%
MSDT A Drain Pressure	psia	184.6	136.0	-26.3%
MSDT A Drain Temperature	°F	375.1	350.8	-24.3°F
RH1 A Drain Flow	lbm/hr	135,811	90,676	-33.2%
RH1 A Drain Enthalpy	BTU/lbm	451.2	420.3	-6.9%

Attachment A
PEPSE Modeling for 30%, 50%, and 70% Extraction

Description	Units	0%	30%	Δ (30%)
RH1 A Drain Pressure	psia	444.2	332.0	-25.3%
RH1 A Drain Temperature	°F	455.0	426.7	-28.3°F
RH2 A Drain Flow	lbm/hr	200,587	192,740	-3.9%
RH2 A Drain Enthalpy	BTU/lbm	534.5	534.8	0.1%
RH2 A Drain Pressure	psia	865.1	866.9	0.2%
RH2 A Drain Temperature	°F	527.3	527.5	0.2°F
MSDT B Drain Flow	lbm/hr	331,167	192,757	-41.8%
MSDT B Drain Enthalpy	BTU/lbm	348.4	322.6	-7.4%
MSDT B Drain Pressure	psia	184.6	136.0	-26.3%
MSDT B Drain Temperature	°F	375.1	350.8	-24.3°F
RH1 B Drain Flow	lbm/hr	135,811	90,676	-33.2%
RH1 B Drain Enthalpy	BTU/lbm	451.2	420.3	-6.9%
RH1 B Drain Pressure	psia	444.2	332.0	-25.3%
RH1 B Drain Temperature	°F	455.0	426.7	-28.3°F
RH2 B Drain Flow	lbm/hr	200,731	192,982	-3.9%
RH2 B Drain Enthalpy	BTU/lbm	535.2	535.4	0.0%
RH2 B Drain Pressure	psia	869.3	870.8	0.2%
RH2 B Drain Temperature	°F	527.9	528.1	0.2°F
MSDT C Drain Flow	lbm/hr	331,167	192,757	-41.8%
MSDT C Drain Enthalpy	BTU/lbm	348.4	322.6	-7.4%
MSDT C Drain Pressure	psia	184.6	136.0	-26.3%
MSDT C Drain Temperature	°F	375.1	350.8	-24.3°F
RH1 C Drain Flow	lbm/hr	135,811	90,676	-33.2%
RH1 C Drain Enthalpy	BTU/lbm	451.2	420.3	-6.9%
RH1 C Drain Pressure	psia	444.2	332.0	-25.3%
RH1 C Drain Temperature	°F	455.0	426.7	-28.3°F
RH2 C Drain Flow	lbm/hr	200,371	192,469	-3.9%
RH2 C Drain Enthalpy	BTU/lbm	533.9	534.2	0.1%
RH2 C Drain Pressure	psia	861.3	863.5	0.2%
RH2 C Drain Temperature	°F	526.8	527.1	0.3°F
MSDT D Drain Flow	lbm/hr	331,167	192,757	-41.8%
MSDT D Drain Enthalpy	BTU/lbm	348.4	322.6	-7.4%
MSDT D Drain Pressure	psia	184.6	136.0	-26.3%
MSDT D Drain Temperature	°F	375.1	350.8	-24.3°F
RH1 D Drain Flow	lbm/hr	135,811	90,676	-33.2%
RH1 D Drain Enthalpy	BTU/lbm	451.2	420.3	-6.9%
RH1 D Drain Pressure	psia	444.2	332.0	-25.3%
RH1 D Drain Temperature	°F	455.0	426.7	-28.3°F

Attachment A
PEPSE Modeling for 30%, 50%, and 70% Extraction

Description	Units	0%	30%	Δ (30%)
RH2 D Drain Flow	lbm/hr	200,264	192,389	-3.9%
RH2 D Drain Enthalpy	BTU/lbm	533.8	534.2	0.1%
RH2 D Drain Pressure	psia	861.0	863.2	0.2%
RH2 D Drain Temperature	°F	526.7	527.0	0.3°F

Table A5.4: Turbine Impacts – 30% Thermal Extraction

Description	Units	0%	30%	Δ (30%)
MSR to LPT A Flow	lbm/hr	3,673,069	2,677,248	-27.1%
MSR to LPT A Enthalpy	BTU/lbm	1,273.9	1,283.4	0.7%
LPT A Inlet Pressure	psia	175.5	129.3	-26.3%
LPT A Inlet Temperature	°F	504.2	513.4	9.2°F
MSR to LPT B Flow	lbm/hr	3,673,069	2,677,248	-27.1%
MSR to LPT B Enthalpy	BTU/lbm	1,273.9	1,283.4	0.7%
LPT B Inlet Pressure	psia	175.7	129.4	-26.3%
LPT B Inlet Temperature	°F	504.2	513.4	9.2°F
MSR to LPT C Flow	lbm/hr	3,673,069	2,677,249	-27.1%
MSR to LPT C Enthalpy	BTU/lbm	1,273.9	1,283.4	0.7%
LPT C Inlet Pressure	psia	175.7	129.4	-26.3%
LPT C Inlet Temperature	°F	504.2	513.4	9.2°F
HPT to 7th Stage FWHs Flow	lbm/hr	515,692	394,398	-23.5%
HPT to 7th Stage FWHs Enthalpy	BTU/lbm	1,144.6	1,159.7	1.3%
HPT to 7th Stage FWHs Pressure	psia	408.7	303.0	-25.9%
HPT to 6th Stage FWHs Flow	lbm/hr	800,695	696,247	-13.0%
HPT to 6th Stage FWHs Enthalpy	BTU/lbm	1,114.2	1,130.8	1.5%
HPT to 6th Stage FWHs Pressure	psia	287.1	212.7	-25.9%
HPT to 5th Stage FWHs Flow	lbm/hr	746,538	747,410	0.1%
HPT to 5th Stage FWHs Enthalpy	BTU/lbm	1,104.0	1,115.3	1.0%
HPT to 5th Stage FWHs Pressure	psia	186.1	137.1	-26.3%
LPT A to FWH 1A Flow	lbm/hr	219,611	176,583	-19.6%
LPT A to FWH 1A Enthalpy	BTU/lbm	729.4	797.3	9.3%
LPT A to FWH 1A Pressure	psia	5.43	3.64	-33.0%
LPT A to FWH 2A Flow	lbm/hr	196,662	177,570	-9.7%
LPT A to FWH 2A Enthalpy	BTU/lbm	969.8	1,011.7	4.3%
LPT A to FWH 2A Pressure	psia	15.91	10.82	-32.0%
LPT A to FWH 3A Flow	lbm/hr	198,518	193,908	-2.3%
LPT A to FWH 3A Enthalpy	BTU/lbm	1,158.7	1,162.2	0.3%
LPT A to FWH 3A Pressure	psia	40.6	28.2	-30.6%
LPT A to FWH 4A Flow	lbm/hr	202,828	197,755	-2.5%

Attachment A
PEPSE Modeling for 30%, 50%, and 70% Extraction

Description	Units	0%	30%	Δ (30%)
LPT A to FWH 4A Enthalpy	BTU/lbm	1,219.2	1,225.5	0.5%
LPT A to FWH 4A Pressure	psia	89.5	64.5	-28.0%
LPT B to FWH 1B Flow	lbm/hr	221,057	177,472	-19.7%
LPT B to FWH 1B Enthalpy	BTU/lbm	730.6	800.9	9.6%
LPT B to FWH 1B Pressure	psia	5.41	3.62	-33.0%
LPT B to FWH 2B Flow	lbm/hr	205,217	184,728	-10.0%
LPT B to FWH 2B Enthalpy	BTU/lbm	972.9	1,020.5	4.9%
LPT B to FWH 2B Pressure	psia	15.87	10.79	-32.0%
LPT B to FWH 3B Flow	lbm/hr	195,125	191,042	-2.1%
LPT B to FWH 3B Enthalpy	BTU/lbm	1,158.7	1,162.2	0.3%
LPT B to FWH 3B Pressure	psia	40.6	28.2	-30.6%
LPT B to FWH 4B Flow	lbm/hr	204,306	199,109	-2.5%
LPT B to FWH 4B Enthalpy	BTU/lbm	1,219.1	1,225.4	0.5%
LPT B to FWH 4B Pressure	psia	89.5	64.5	-28.0%
LPT C to FWH 1C Flow	lbm/hr	219,850	176,703	-19.6%
LPT C to FWH 1C Enthalpy	BTU/lbm	729.7	797.4	9.3%
LPT C to FWH 1C Pressure	psia	5.42	3.63	-33.1%
LPT C to FWH 2C Flow	lbm/hr	207,613	188,354	-9.3%
LPT C to FWH 2C Enthalpy	BTU/lbm	976.3	1,016.5	4.1%
LPT C to FWH 2C Pressure	psia	15.88	10.79	-32.0%
LPT C to FWH 3C Flow	lbm/hr	195,223	191,228	-2.0%
LPT C to FWH 3C Enthalpy	BTU/lbm	1,158.8	1,162.4	0.3%
LPT C to FWH 3C Pressure	psia	40.6	28.2	-30.5%
LPT C to FWH 4C Flow	lbm/hr	199,621	194,435	-2.6%
LPT C to FWH 4C Enthalpy	BTU/lbm	1,219.2	1,225.6	0.5%
LPT C to FWH 4C Pressure	psia	89.6	64.6	-27.9%

Table A5.5: Feedwater Heater Impacts – 30% Thermal Extraction

Description	Units	0%	30%	Δ (30%)
DC 1A Discharge Temp	°F	126.3	113.3	-13.0°F
FWH 1A Discharge Temp	°F	161.1	144.2	-16.9°F
FWH 1A Extraction Pressure	psia	5.43	3.64	-33.0%
FWH 1A Drain Temp	°F	165.3	148.4	-16.8°F
FWH 2A Discharge Temp	°F	210.1	189.9	-20.2°F
FWH 2A Extraction Pressure	psia	15.91	10.82	-32.0%
FWH 2A Drain Temp	°F	169.8	151.9	-17.9°F
FWH 3A Discharge Temp	°F	263.1	241.3	-21.8°F
FWH 3A Extraction Pressure	psia	40.6	28.2	-30.6%

Attachment A
PEPSE Modeling for 30%, 50%, and 70% Extraction

Description	Units	0%	30%	Δ (30%)
FWH 3A Drain Temp	°F	224.4	203.6	-20.8°F
FWH 4A Discharge Temp	°F	314.3	291.3	-23.0°F
FWH 4A Extraction Pressure	psia	89.5	64.5	-28.0%
FWH 4A Drain Temp	°F	274.0	251.6	-22.4°F
DC 5A Discharge Temp	°F	331.4	306.0	-25.5°F
FWH 5A Discharge Temp	°F	369.9	345.6	-24.3°F
FWH 5A Extraction Pressure	psia	186.1	137.1	-26.3%
FWH 5A Drain Temp	°F	375.8	351.4	-24.4°F
FWH 6A Discharge Temp	°F	409.5	383.5	-25.9°F
FWH 6A Extraction Pressure	psia	287.1	212.7	-25.9%
FWH 6A Drain Temp	°F	374.3	348.7	-25.6°F
FWH 7A Discharge Temp	°F	440.2	412.7	-27.5°F
FWH 7A Extraction Pressure	psia	408.7	303.0	-25.9%
FWH 7A Drain Temp	°F	420.2	392.4	-27.8°F
DC 1B Discharge Temp	°F	126.6	113.5	-13.1°F
FWH 1B Discharge Temp	°F	161.7	144.8	-16.9°F
FWH 1B Extraction Pressure	psia	5.41	3.62	-33.0%
FWH 1B Drain Temp	°F	165.1	148.3	-16.8°F
FWH 2B Discharge Temp	°F	212.8	192.6	-20.2°F
FWH 2B Extraction Pressure	psia	15.87	10.79	-32.0%
FWH 2B Drain Temp	°F	170.2	152.2	-17.9°F
FWH 3B Discharge Temp	°F	265.0	243.3	-21.7°F
FWH 3B Extraction Pressure	psia	40.6	28.2	-30.6%
FWH 3B Drain Temp	°F	225.3	204.5	-20.8°F
FWH 4B Discharge Temp	°F	316.4	293.5	-22.9°F
FWH 4B Extraction Pressure	psia	89.5	64.5	-28.0%
FWH 4B Drain Temp	°F	277.9	255.6	-22.3°F
DC 5B Discharge Temp	°F	332.2	306.8	-25.4°F
FWH 5B Discharge Temp	°F	370.2	345.9	-24.3°F
FWH 5B Extraction Pressure	psia	186.1	137.1	-26.3%
FWH 5B Drain Temp	°F	375.8	351.4	-24.4°F
FWH 6B Discharge Temp	°F	409.7	383.7	-25.9°F
FWH 6B Extraction Pressure	psia	287.1	212.7	-25.9%
FWH 6B Drain Temp	°F	375.5	349.8	-25.7°F
FWH 7B Discharge Temp	°F	441.5	413.8	-27.7°F
FWH 7B Extraction Pressure	psia	408.7	303.0	-25.9%
FWH 7B Drain Temp	°F	421.9	393.8	-28.0°F
DC 1C Discharge Temp	°F	125.9	113.0	-13.0°F

Attachment A
PEPSE Modeling for 30%, 50%, and 70% Extraction

Description	Units	0%	30%	Δ (30%)
FWH 1C Discharge Temp	°F	160.8	143.9	-16.9°F
FWH 1C Extraction Pressure	psia	5.42	3.63	-33.1%
FWH 1C Drain Temp	°F	165.2	148.3	-16.9°F
FWH 2C Discharge Temp	°F	212.7	192.5	-20.3°F
FWH 2C Extraction Pressure	psia	15.88	10.79	-32.0%
FWH 2C Drain Temp	°F	169.9	151.9	-18.0°F
FWH 3C Discharge Temp	°F	264.6	242.9	-21.7°F
FWH 3C Extraction Pressure	psia	40.6	28.2	-30.5%
FWH 3C Drain Temp	°F	226.6	205.7	-20.9°F
FWH 4C Discharge Temp	°F	315.0	292.0	-22.9°F
FWH 4C Extraction Pressure	psia	89.6	64.6	-27.9%
FWH 4C Drain Temp	°F	274.6	252.3	-22.3°F
FWH 1A TTD	°F	4.7	4.9	0.2°F
FWH 1A DCA	°F	7.4	7.4	0.0°F
FWH 2A TTD	°F	5.9	7.0	1.1°F
FWH 2A DCA	°F	8.8	7.8	-1.0°F
FWH 3A TTD	°F	5.0	5.5	0.5°F
FWH 3A DCA	°F	14.3	13.6	-0.6°F
FWH 4A TTD	°F	5.6	6.2	0.6°F
FWH 4A DCA	°F	10.9	10.3	-0.5°F
FWH 5A TTD	°F	5.9	5.9	0.0°F
FWH 5A DCA	°F	6.2	4.2	-2.0°F
FWH 6A TTD	°F	3.9	3.5	-0.4°F
FWH 6A DCA	°F	4.4	3.1	-1.2°F
FWH 7A TTD	°F	6.5	5.6	-0.9°F
FWH 7A DCA	°F	7.5	5.8	-1.7°F
FWH 1B TTD	°F	3.9	4.2	0.3°F
FWH 1B DCA	°F	6.6	6.6	0.0°F
FWH 2B TTD	°F	3.1	4.2	1.1°F
FWH 2B DCA	°F	8.5	7.5	-1.0°F
FWH 3B TTD	°F	3.1	3.5	0.4°F
FWH 3B DCA	°F	12.5	11.9	-0.6°F
FWH 4B TTD	°F	3.5	4.0	0.5°F
FWH 4B DCA	°F	12.9	12.3	-0.6°F
FWH 5B TTD	°F	5.6	5.5	0.0°F
FWH 5B DCA	°F	6.1	4.2	-2.0°F
FWH 6B TTD	°F	3.7	3.3	-0.4°F
FWH 6B DCA	°F	5.3	3.9	-1.4°F

Attachment A
PEPSE Modeling for 30%, 50%, and 70% Extraction

Description	Units	0%	30%	Δ (30%)
FWH 7B TTD	°F	5.2	4.4	-0.8°F
FWH 7B DCA	°F	9.2	7.2	-2.0°F
FWH 1C TTD	°F	4.9	5.1	0.2°F
FWH 1C DCA	°F	9.3	9.3	0.0°F
FWH 2C TTD	°F	3.2	4.4	1.2°F
FWH 2C DCA	°F	9.1	8.0	-1.1°F
FWH 3C TTD	°F	3.6	4.0	0.4°F
FWH 3C DCA	°F	13.9	13.3	-0.6°F
FWH 4C TTD	°F	5.0	5.5	0.5°F
FWH 4C DCA	°F	10.0	9.4	-0.5°F
Final FW Temperature	°F	440.9	413.2	-27.6°F
Final FW Flow	lbm/hr	16,067,280	15,466,190	-3.7%
Heater Drain Tank Pressure	psia	185.1	136.5	-26.3%
Heater Drain Tank Temperature	°F	336.6	307.7	-28.8°F
FWH 7A Drain Flow	lbm/hr	650,363	575,781	-11.5%
FWH 7B Drain Flow	lbm/hr	667,282	589,198	-11.7%
FWH 6A Drain Flow	lbm/hr	1,051,707	924,845	-12.1%
FWH 6B Drain Flow	lbm/hr	1,066,632	936,381	-12.2%
DC 5A Drain Flow	lbm/hr	1,698,661	1,481,925	-12.8%
DC 5B Drain Flow	lbm/hr	1,709,462	1,489,413	-12.9%
FWH 4A Drain Flow	lbm/hr	202,828	197,755	-2.5%
FWH 4B Drain Flow	lbm/hr	204,306	199,109	-2.5%
FWH 4C Drain Flow	lbm/hr	199,621	194,435	-2.6%
FWH 3A Drain Flow	lbm/hr	401,346	391,662	-2.4%
FWH 3B Drain Flow	lbm/hr	399,431	390,151	-2.3%
FWH 3C Drain Flow	lbm/hr	394,844	385,663	-2.3%
FWH 2A Drain Flow	lbm/hr	598,008	569,232	-4.8%
FWH 2B Drain Flow	lbm/hr	604,648	574,879	-4.9%
FWH 2C Drain Flow	lbm/hr	602,457	574,017	-4.7%
DC 1A Drain Flow	lbm/hr	817,619	745,815	-8.8%
DC 1B Drain Flow	lbm/hr	825,705	752,351	-8.9%
DC 1C Drain Flow	lbm/hr	822,307	750,720	-8.7%

Table A5.6: Condenser Impacts – 30% Thermal Extraction

Description	Units	0%	30%	Δ (30%)
Condenser A Shell Pressure	psia	1.242	1.007	-18.9%
Condenser B Shell Pressure	psia	1.381	1.071	-22.5%
Condenser C Shell Pressure	psia	1.642	1.218	-25.9%

Attachment A
PEPSE Modeling for 30%, 50%, and 70% Extraction

Description	Units	0%	30%	Δ (30%)
CW Inlet Temperature	°F	83.3	83.3	0.0°F
CW Outlet Temperature	°F	105.6	99.0	-6.6°F

Table A5.7: Pump Impacts – 30% Thermal Extraction

Description	Units	0%	30%	Δ (30%)
Condensate Pumps dP	psid	139.9	140.3	0.3%
Condensate Booster Pumps dP	psid	398.5	398.5	0.0%
Condensate Flow	lbm/hr	11,334,490	11,723,820	3.4%
FWP A Flow	lbm/hr	8,033,640	7,733,095	-3.7%
FWP A dP	psid	659.4	665.2	0.9%
FWPT A Steam Flow	lbm/hr	130,855	131,974	0.9%
FWPT A Inlet Pressure	psia	173.9	128.1	-26.3%
FWPT A Inlet Enthalpy	BTU/lbm	1,273.9	1,283.4	0.7%
FWP B Flow	lbm/hr	8,033,640	7,733,095	-3.7%
FWP B dP	psid	659.4	665.2	0.9%
FWPT B Steam Flow	lbm/hr	130,855	131,974	0.9%
FWPT B Inlet Pressure	psia	173.9	128.1	-26.3%
FWPT B Inlet Enthalpy	BTU/lbm	1,273.9	1,283.4	0.7%

A6 Results of 50% Thermal Extraction

Analysis is also done to evaluate the impacts for 50% thermal extraction. At this extraction level, however, the FWH 2 normal drain control valve exhibits a negative pressure loss, which is not possible. To maintain normal operation, an additional case is run which adds a bypass to divert 20% of the condensate flow around the FWHs. The PEPSE diagrams (located at the end of the Attachment A) show the results for these cases, and Tables A6.1-A6.7 compare important operating parameters within the nuclear power cycle to determine possible significant impact to station equipment.

Another case is run with emergency valves open for FWHs 2 and 3. This results in a gross generator output of 582.9 MW which is a loss of 2.4 MW from the normal 50% thermal extraction case. This case is documented in PEPSE, but no heat balance diagrams are generated.

Table A6.1: General Impacts – 50% Thermal Extraction

Description	Units	0%	50%	Δ (50%)	50% w/ Bypass	Δ (50% w/ Bypass)
Generator Electric Power	MWe	1,228.0	585.3	-52.3%	573.13	-53.3%
Thermal Power Extracted	MWt	0	1,827	-	1,826.38	-
% of Flow - MS	%	0	37.6	-	37.7	-
MS Flow	lbm/hr	16,037,390	14,952,560	-7%	14,916,170	-7.0%
HP Turbine Inlet Flow	lbm/hr	15,218,400	8,615,524	-43%	8,619,505	-43.4%

Attachment A
PEPSE Modeling for 30%, 50%, and 70% Extraction

Description	Units	0%	50%	Δ (50%)	50% w/ Bypass	Δ (50% w/ Bypass)
HP Turbine First Stage Pressure	psia	651.5	374.8	-42%	375.2	-42.4%
MSR Inlet Pressure	psia	190.3	104.6	-45%	97.6	-48.7%
LP Turbine Inlet Flow	lbm/hr	3,673,069	1,980,267	-46%	1,845,837	-49.7%
LP Turbine Inlet Pressure	psia	175.5	96.43	-45%	90.04	-48.7%
Condenser Duty	BTU/hr	8.21E+09	4.18E+09	-49%	4.22E+09	-48.6%
Condensate Pump Flow	lbm/hr	11,334,490	11,889,450	4.9%	11,475,500	1.2%
Heater Drain Pump Flow	lbm/hr	4,732,792	3,093,006	-35%	3,470,571	-26.7%
Feedwater Pump Flow	lbm/hr	16,067,280	14,982,480	-6.8%	14,946,080	-7.0%
Final Feedwater Temperature	°F	440.9	389.0	-51.9°F	387.1	-53.8°F
Cascading Drain Flow to Condenser	lbm/hr	817,619	670,424	-18%	522,171	-36.1%
Cogen HX Inlet Mass Flow	lbm/hr	-	5,629,289	-	5,628,542	-
Cogen HX Inlet Pressure	psia	-	817.3	-	817.3	-
Cogen HX Inlet Temperature	°F	-	520.7	-	520.7	-
Cogen HX Inlet Enthalpy	BTU/lbm	-	1,197.2	-	1,197.3	-
Cogen HX Outlet Temperature	°F	-	120.0	-	120.0	-
Cogen HX Outlet Enthalpy	BTU/lbm	-	90.1	-	90.05	-

Table A6.2: MSR Impacts – 50% Thermal Extraction

Description	Units	0%	50%	Δ (50%)	50% w/ Bypass	Δ (50% w/ Bypass)
MSR A Removal Effectiveness	-	95.0%	95.0%	0.0%	0.95	0.0%
MSR A Chevrons Inlet Flow	lbm/hr	3,151,396	1,668,457	-47.1%	1,561,720	-50.4%
MSR A Chevrons Inlet Enthalpy	BTU/lbm	1,104.0	1,123.1	1.7%	1,119.2	1.4%
MSR A Chevrons Inlet Pressure	psia	190.3	104.6	-45.0%	97.6	-48.7%
MSR A 1 st Stage Inlet Enthalpy	BTU/lbm	1,192.7	1,184.6	-0.7%	1,183.3	-0.8%
MSR A 1 st Stage Inlet Pressure	psia	184.6	101.4	-45.0%	94.7	-48.7%
MSR A 2 nd Stage Inlet Enthalpy	BTU/lbm	1,226.8	1,216.9	-0.8%	1,217.7	-0.7%
MSR A 2 nd Stage Inlet Pressure	psia	181.8	99.9	-45.0%	93.3	-48.7%
MSR B Removal Effectiveness	-	95.0%	95.0%	0.0%	0.95	0.0%
MSR B Chevrons Inlet Flow	lbm/hr	3,151,396	1,668,457	-47.1%	1,561,720	-50.4%
MSR B Chevrons Inlet Enthalpy	BTU/lbm	1,104.0	1,123.1	1.7%	1,119.2	1.4%
MSR B Chevrons Inlet Pressure	psia	190.3	104.6	-45.0%	97.6	-48.7%
MSR B 1 st Stage Inlet Enthalpy	BTU/lbm	1,192.7	1,184.6	-0.7%	1,183.3	-0.8%
MSR B 1 st Stage Inlet Pressure	psia	184.6	101.4	-45.0%	94.7	-48.7%
MSR B 2 nd Stage Inlet Enthalpy	BTU/lbm	1,226.8	1,216.9	-0.8%	1,217.7	-0.7%
MSR B 2 nd Stage Inlet Pressure	psia	181.8	99.9	-45.0%	93.3	-48.7%
MSR C Removal Effectiveness	-	95.0%	95.0%	0.0%	1.0	0.0%

Attachment A
PEPSE Modeling for 30%, 50%, and 70% Extraction

Description	Units	0%	50%	Δ (50%)	50% w/ Bypass	Δ (50% w/ Bypass)
MSR C Chevrons Inlet Flow	lbm/hr	3,151,396	1,668,457	-47.1%	1,561,720	-50.4%
MSR C Chevrons Inlet Enthalpy	BTU/lbm	1,104.0	1,123.1	1.7%	1,119.2	1.4%
MSR C Chevrons Inlet Pressure	psia	190.3	104.6	-45.0%	97.6	-48.7%
MSR C 1 st Stage Inlet Enthalpy	BTU/lbm	1,192.7	1,184.6	-0.7%	1,183.3	-0.8%
MSR C 1 st Stage Inlet Pressure	psia	184.6	101.4	-45.0%	94.7	-48.7%
MSR C 2 nd Stage Inlet Enthalpy	BTU/lbm	1,226.8	1,216.9	-0.8%	1,217.7	-0.7%
MSR C 2 nd Stage Inlet Pressure	psia	181.8	99.9	-45.0%	93.3	-48.7%
MSR D Removal Effectiveness	-	95.0%	95.0%	0.0%	1.0	0.0%
MSR D Chevrons Inlet Flow	lbm/hr	3,151,396	1,668,457	-47.1%	1,561,720	-50.4%
MSR D Chevrons Inlet Enthalpy	BTU/lbm	1,104.0	1,123.1	1.7%	1,119.2	1.4%
MSR D Chevrons Inlet Pressure	psia	190.3	104.6	-45.0%	97.6	-48.7%
MSR D 1 st Stage Inlet Enthalpy	BTU/lbm	1,192.7	1,184.6	-0.7%	1,183.3	-0.8%
MSR D 1 st Stage Inlet Pressure	psia	184.6	101.4	-45.0%	94.7	-48.7%
MSR D 2 nd Stage Inlet Enthalpy	BTU/lbm	1,226.8	1,216.9	-0.8%	1,217.7	-0.7%
MSR D 2 nd Stage Inlet Pressure	psia	181.8	99.9	-45.0%	93.3	-48.7%

Table A6.3: MSR Drain Impacts – 50% Thermal Extraction

Description	Units	0%	50%	Δ (50%)	50% w/ Bypass	Δ (50% w/ Bypass)
MSDT A Drain Flow	lbm/hr	331,167	116,108	-64.9%	112,625	-66.0%
MSDT A Drain Enthalpy	BTU/lbm	348.4	299.6	-14.0%	294.5	-15.5%
MSDT A Drain Pressure	psia	184.6	101.4	-45.0%	94.7	-48.7%
MSDT A Drain Temperature	°F	375.1	328.8	-46.3°F	323.9	-51.2°F
RH1 A Drain Flow	lbm/hr	135,811	63,649	-53.1%	63,355	-53.4%
RH1 A Drain Enthalpy	BTU/lbm	451.2	394.3	-12.6%	394.0	-12.7%
RH1 A Drain Pressure	psia	444.2	254.6	-42.7%	253.7	-42.9%
RH1 A Drain Temperature	°F	455.0	402.6	-52.4°F	402.3	-52.7°F
RH2 A Drain Flow	lbm/hr	200,587	172,667	-13.9%	162,752	-18.9%
RH2 A Drain Enthalpy	BTU/lbm	534.5	535.5	0.2%	535.8	0.2%
RH2 A Drain Pressure	psia	865.1	871.2	0.7%	873.1	0.9%
RH2 A Drain Temperature	°F	527.3	528.1	0.8°F	528.4	1.1°F
MSDT B Drain Flow	lbm/hr	331,167	116,108	-64.9%	112,625	-66.0%
MSDT B Drain Enthalpy	BTU/lbm	348.4	299.6	-14.0%	294.5	-15.5%
MSDT B Drain Pressure	psia	184.6	101.4	-45.0%	94.7	-48.7%
MSDT B Drain Temperature	°F	375.1	328.8	-46.3°F	323.9	-51.2°F
RH1 B Drain Flow	lbm/hr	135,811	63,649	-53.1%	63,355	-53.4%
RH1 B Drain Enthalpy	BTU/lbm	451.2	394.3	-12.6%	394.0	-12.7%
RH1 B Drain Pressure	psia	444.2	254.6	-42.7%	253.7	-42.9%

Attachment A
PEPSE Modeling for 30%, 50%, and 70% Extraction

Description	Units	0%	50%	Δ (50%)	50% w/ Bypass	Δ (50% w/ Bypass)
RH1 B Drain Temperature	°F	455.0	402.6	-52.4°F	402.3	-52.7°F
RH2 B Drain Flow	lbm/hr	200,731	172,916	-13.9%	162,970	-18.8%
RH2 B Drain Enthalpy	BTU/lbm	535.2	536.0	0.1%	536.2	0.2%
RH2 B Drain Pressure	psia	869.3	874.3	0.6%	875.8	0.7%
RH2 B Drain Temperature	°F	527.9	528.5	0.7°F	528.7	0.9°F
MSDT C Drain Flow	lbm/hr	331,167	116,108	-64.9%	112,625	-66.0%
MSDT C Drain Enthalpy	BTU/lbm	348.4	299.6	-14.0%	294.5	-15.5%
MSDT C Drain Pressure	psia	184.6	101.4	-45.0%	94.7	-48.7%
MSDT C Drain Temperature	°F	375.1	328.8	-46.3°F	323.9	-51.2°F
RH1 C Drain Flow	lbm/hr	135,811	63,649	-53.1%	63,355	-53.4%
RH1 C Drain Enthalpy	BTU/lbm	451.2	394.3	-12.6%	394.0	-12.7%
RH1 C Drain Pressure	psia	444.2	254.6	-42.7%	253.7	-42.9%
RH1 C Drain Temperature	°F	455.0	402.6	-52.4°F	402.3	-52.7°F
RH2 C Drain Flow	lbm/hr	200,371	172,420	-13.9%	162,531	-18.9%
RH2 C Drain Enthalpy	BTU/lbm	533.9	535.0	0.2%	535.4	0.3%
RH2 C Drain Pressure	psia	861.3	868.4	0.8%	870.7	1.1%
RH2 C Drain Temperature	°F	526.8	527.7	1.0°F	528.0	1.3°F
MSDT D Drain Flow	lbm/hr	331,167	116,108	-64.9%	112,625	-66.0%
MSDT D Drain Enthalpy	BTU/lbm	348.4	299.6	-14.0%	294.5	-15.5%
MSDT D Drain Pressure	psia	184.6	101.4	-45.0%	94.7	-48.7%
MSDT D Drain Temperature	°F	375.1	328.8	-46.3°F	323.9	-51.2°F
RH1 D Drain Flow	lbm/hr	135,811	63,649	-53.1%	63,355	-53.4%
RH1 D Drain Enthalpy	BTU/lbm	451.2	394.3	-12.6%	394.0	-12.7%
RH1 D Drain Pressure	psia	444.2	254.6	-42.7%	253.7	-42.9%
RH1 D Drain Temperature	°F	455.0	402.6	-52.4°F	402.3	-52.7°F
RH2 D Drain Flow	lbm/hr	200,264	172,369	-13.9%	162,489	-18.9%
RH2 D Drain Enthalpy	BTU/lbm	533.8	535.0	0.2%	535.3	0.3%
RH2 D Drain Pressure	psia	861.0	868.2	0.8%	870.4	1.1%
RH2 D Drain Temperature	°F	526.7	527.7	1.0°F	528.0	1.3°F

Table A6.4: Turbine Impacts – 50% Thermal Extraction

Description	Units	0%	50%	Δ (50%)	50% w/ Bypass	Δ (50% w/ Bypass)
MSR to LPT A Flow	lbm/hr	3,673,069	1,980,267	-46.1%	1,845,837	-49.7%
MSR to LPT A Enthalpy	BTU/lbm	1,273.9	1290.5	1.3%	1,292.0	1.4%
LPT A Inlet Pressure	psia	175.5	96.4	-45.0%	90.0	-48.7%
LPT A Inlet Temperature	°F	504.2	521.4	17.2°F	523.2	19.0°F

Attachment A
PEPSE Modeling for 30%, 50%, and 70% Extraction

Description	Units	0%	50%	Δ (50%)	50% w/ Bypass	Δ (50% w/ Bypass)
MSR to LPT B Flow	lbm/hr	3,673,069	1,980,267	-46.1%	1,845,837	-49.7%
MSR to LPT B Enthalpy	BTU/lbm	1,273.9	1290.5	1.3%	1,292.0	1.4%
LPT B Inlet Pressure	psia	175.7	96.5	-45.0%	90.1	-48.7%
LPT B Inlet Temperature	°F	504.2	521.4	17.2°F	523.2	19.0°F
MSR to LPT C Flow	lbm/hr	3,673,069	1,980,267	-46.1%	1,845,837	-49.7%
MSR to LPT C Enthalpy	BTU/lbm	1,273.9	1290.5	1.3%	1,292.0	1.4%
LPT C Inlet Pressure	psia	175.7	96.5	-45.0%	90.1	-48.7%
LPT C Inlet Temperature	°F	504.2	521.4	17.2°F	523.2	19.0°F
HPT to 7th Stage FWHs Flow	lbm/hr	515,692	316,939	-38.5%	334,319	-35.2%
HPT to 7th Stage FWHs Enthalpy	BTU/lbm	1,144.6	1172.6	2.4%	1,173.7	2.5%
HPT to 7th Stage FWHs Pressure	psia	408.7	229.2	-43.9%	224.5	-45.1%
HPT to 6th Stage FWHs Flow	lbm/hr	800,695	634,105	-20.8%	720,700	-10.0%
HPT to 6th Stage FWHs Enthalpy	BTU/lbm	1,114.2	1143.5	2.6%	1,143.8	2.7%
HPT to 6th Stage FWHs Pressure	psia	287.1	161.3	-43.8%	157.5	-45.1%
HPT to 5th Stage FWHs Flow	lbm/hr	746,538	732,534	-1.9%	1,060,894	42.1%
HPT to 5th Stage FWHs Enthalpy	BTU/lbm	1,104.0	1123.1	1.7%	1,119.2	1.4%
HPT to 5th Stage FWHs Pressure	psia	186.1	102.3	-45.0%	95.5	-48.7%
LPT A to FWH 1A Flow	lbm/hr	219,611	133,604	-39.2%	112,997	-48.5%
LPT A to FWH 1A Enthalpy	BTU/lbm	729.4	841.6	15.4%	822.8	12.8%
LPT A to FWH 1A Pressure	psia	5.43	2.4	-55.0%	2.5	-54.5%
LPT A to FWH 2A Flow	lbm/hr	196,662	156,611	-20.4%	125,608	-36.1%
LPT A to FWH 2A Enthalpy	BTU/lbm	969.8	1038.2	7.0%	1,038.5	7.1%
LPT A to FWH 2A Pressure	psia	15.91	7.3	-53.9%	7.3	-54.0%
LPT A to FWH 3A Flow	lbm/hr	198,518	189,677	-4.5%	142,079	-28.4%
LPT A to FWH 3A Enthalpy	BTU/lbm	1,158.7	1162.7	0.3%	1,167.3	0.7%
LPT A to FWH 3A Pressure	psia	40.6	19.7	-51.5%	19.4	-52.3%
LPT A to FWH 4A Flow	lbm/hr	202,828	190,532	-6.1%	141,487	-30.2%
LPT A to FWH 4A Enthalpy	BTU/lbm	1,219.2	1229.4	0.8%	1,232.7	1.1%
LPT A to FWH 4A Pressure	psia	89.5	46.8	-47.7%	44.8	-50.0%
LPT B to FWH 1B Flow	lbm/hr	221,057	134,067	-39.4%	113,314	-48.7%
LPT B to FWH 1B Enthalpy	BTU/lbm	730.6	845.6	15.7%	827.1	13.2%
LPT B to FWH 1B Pressure	psia	5.41	2.4	-55.1%	2.5	-54.4%
LPT B to FWH 2B Flow	lbm/hr	205,217	162,965	-20.6%	128,677	-37.3%

Attachment A
PEPSE Modeling for 30%, 50%, and 70% Extraction

Description	Units	0%	50%	Δ (50%)	50% w/ Bypass	Δ (50% w/ Bypass)
LPT B to FWH 2B Enthalpy	BTU/lbm	972.9	1047.8	7.7%	1,048.1	7.7%
LPT B to FWH 2B Pressure	psia	15.87	7.3	-54.0%	7.3	-53.9%
LPT B to FWH 3B Flow	lbm/hr	195,125	188,055	-3.6%	140,494	-28.0%
LPT B to FWH 3B Enthalpy	BTU/lbm	1,158.7	1162.7	0.3%	1,167.3	0.7%
LPT B to FWH 3B Pressure	psia	40.6	19.7	-51.5%	19.4	-52.3%
LPT B to FWH 4B Flow	lbm/hr	204,306	191,817	-6.1%	142,155	-30.4%
LPT B to FWH 4B Enthalpy	BTU/lbm	1,219.1	1229.3	0.8%	1,232.5	1.1%
LPT B to FWH 4B Pressure	psia	89.5	46.8	-47.8%	44.7	-50.0%
LPT C to FWH 1C Flow	lbm/hr	219,850	133,660	-39.2%	113,376	-48.4%
LPT C to FWH 1C Enthalpy	BTU/lbm	729.7	841.7	15.3%	823.5	12.8%
LPT C to FWH 1C Pressure	psia	5.42	2.4	-55.1%	2.5	-54.5%
LPT C to FWH 2C Flow	lbm/hr	207,613	166,147	-20.0%	131,056	-36.9%
LPT C to FWH 2C Enthalpy	BTU/lbm	976.3	1041.4	6.7%	1,040.9	6.6%
LPT C to FWH 2C Pressure	psia	15.88	7.3	-54.0%	7.3	-54.0%
LPT C to FWH 3C Flow	lbm/hr	195,223	188,271	-3.6%	140,745	-27.9%
LPT C to FWH 3C Enthalpy	BTU/lbm	1,158.8	1162.8	0.4%	1,167.4	0.7%
LPT C to FWH 3C Pressure	psia	40.6	19.7	-51.4%	19.4	-52.3%
LPT C to FWH 4C Flow	lbm/hr	199,621	187,309	-6.2%	139,798	-30.0%
LPT C to FWH 4C Enthalpy	BTU/lbm	1,219.2	1229.5	0.8%	1,232.7	1.1%
LPT C to FWH 4C Pressure	psia	89.6	46.9	-47.7%	44.8	-50.0%

Table A6.5: Feedwater Heater Impacts – 50% Thermal Extraction

Description	Units	0%	50%	Δ (50%)	50% w/ Bypass	Δ (50% w/ Bypass)
DC 1A Discharge Temp	°F	126.3	103.9	-22.4°F	104.1	-22.2°F
FWH 1A Discharge Temp	°F	161.1	129.0	-32.1°F	130.8	-30.2°F
FWH 1A Extraction Pressure	psia	5.43	2.44	-55.0%	2.47	-54.5%
FWH 1A Drain Temp	°F	165.3	132.7	-32.5 °F	133.5	-31.8 °F
FWH 2A Discharge Temp	°F	210.1	170.7	-39.5°F	173.7	-36.4°F
FWH 2A Extraction Pressure	psia	15.9	7.34	-53.9%	7.32	-54.0%
FWH 2A Drain Temp	°F	169.8	135.6	-34.2°F	135.3	-34.6°F
FWH 3A Discharge Temp	°F	263.1	221.2	-41.9°F	222.9	-40.2°F
FWH 3A Extraction Pressure	psia	40.6	19.7	-51.5%	19.4	-52.3%
FWH 3A Drain Temp	°F	224.4	183.9	-40.5°F	182.5	-41.9°F
FWH 4A Discharge Temp	°F	314.3	270.2	-44.2°F	270.2	-44.1°F
FWH 4A Extraction Pressure	psia	89.5	46.8	-47.7%	44.8	-50.0%
FWH 4A Drain Temp	°F	274.0	230.9	-43°F	228.9	-45.1°F
DC 5A Discharge Temp	°F	331.4	283.1	-48.3°F	258.1	-73.3°F

Attachment A
PEPSE Modeling for 30%, 50%, and 70% Extraction

Description	Units	0%	50%	Δ (50%)	50% w/ Bypass	Δ (50% w/ Bypass)
FWH 5A Discharge Temp	°F	369.9	323.6	-46.3°F	315.6	-54.3°F
FWH 5A Extraction Pressure	psia	186.1	102.3	-45.0%	95.5	-48.7%
FWH 5A Drain Temp	°F	375.8	329.4	-46.4°F	324.3	-51.5°F
FWH 6A Discharge Temp	°F	409.5	360.9	-48.6°F	358.4	-51.1°F
FWH 6A Extraction Pressure	psia	287.1	161.3	-43.8%	157.5	-45.1%
FWH 6A Drain Temp	°F	374.3	325.9	-48.4°F	318.5	-55.8°F
FWH 7A Discharge Temp	°F	440.2	388.5	-51.8°F	386.5	-53.7°F
FWH 7A Extraction Pressure	psia	408.7	229.2	-43.9%	224.5	-45.1%
FWH 7A Drain Temp	°F	420.2	368.1	-52.1°F	365.4	-54.7°F
DC 1B Discharge Temp	°F	126.6	104.1	-22.5°F	104.3	-22.3°F
FWH 1B Discharge Temp	°F	161.7	129.4	-32.3°F	131.3	-30.4°F
FWH 1B Extraction Pressure	psia	5.41	2.43	-55.1%	2.47	-54.4%
FWH 1B Drain Temp	°F	165.1	132.5	-32.6°F	133.4	-31.8°F
FWH 2B Discharge Temp	°F	212.8	173.0	-39.8°F	175.5	-37.3°F
FWH 2B Extraction Pressure	psia	15.87	7.31	-54.0%	7.31	-53.9%
FWH 2B Drain Temp	°F	170.2	135.8	-34.4°F	135.5	-34.7°F
FWH 3B Discharge Temp	°F	265.0	223.3	-41.8°F	224.2	-40.8°F
FWH 3B Extraction Pressure	psia	40.6	19.7	-51.5%	19.4	-52.3%
FWH 3B Drain Temp	°F	225.3	184.7	-40.6°F	183.1	-42.2°F
FWH 4B Discharge Temp	°F	316.4	272.3	-44.1°F	271.6	-44.8°F
FWH 4B Extraction Pressure	psia	89.5	46.8	-47.8%	44.7	-50.0%
FWH 4B Drain Temp	°F	277.9	234.8	-43.1°F	231.8	-46.2°F
DC 5B Discharge Temp	°F	332.2	283.9	-48.2°F	258.3	-73.9°F
FWH 5B Discharge Temp	°F	370.2	323.9	-46.3°F	316.0	-54.3°F
FWH 5B Extraction Pressure	psia	186.1	102.3	-45.0%	95.5	-48.7%
FWH 5B Drain Temp	°F	375.8	329.4	-46.4°F	324.3	-51.5°F
FWH 6B Discharge Temp	°F	409.7	361.1	-48.6°F	358.6	-51.1°F
FWH 6B Extraction Pressure	psia	287.1	161.3	-43.8%	157.5	-45.1%
FWH 6B Drain Temp	°F	375.5	326.8	-48.7°F	319.6	-55.9°F
FWH 7B Discharge Temp	°F	441.5	389.5	-52°F	387.6	-53.9°F
FWH 7B Extraction Pressure	psia	408.7	229.2	-43.9%	224.5	-45.1%
FWH 7B Drain Temp	°F	421.9	369.3	-52.5°F	366.7	-55.2°F
DC 1C Discharge Temp	°F	125.9	103.6	-22.4°F	103.8	-22.2°F
FWH 1C Discharge Temp	°F	160.8	128.7	-32.1°F	130.6	-30.2°F
FWH 1C Extraction Pressure	psia	5.42	2.43	-55.1%	2.47	-54.5%
FWH 1C Drain Temp	°F	165.2	132.6	-32.6°F	133.4	-31.8°F
FWH 2C Discharge Temp	°F	212.7	172.9	-39.9°F	175.4	-37.4°F
FWH 2C Extraction Pressure	psia	15.88	7.3	-54.0%	7.3	-54.0%

Attachment A
PEPSE Modeling for 30%, 50%, and 70% Extraction

Description	Units	0%	50%	Δ (50%)	50% w/ Bypass	Δ (50% w/ Bypass)
FWH 2C Drain Temp	°F	169.9	135.5	-34.3°F	135.2	-34.7°F
FWH 3C Discharge Temp	°F	264.6	222.9	-41.8°F	224.0	-40.6°F
FWH 3C Extraction Pressure	psia	40.6	19.7	-51.4%	19.4	-52.3%
FWH 3C Drain Temp	°F	226.6	185.9	-40.7°F	184.1	-42.5°F
FWH 4C Discharge Temp	°F	315.0	270.9	-44°F	270.7	-44.3°F
FWH 4C Extraction Pressure	psia	89.6	46.9	-47.7%	44.8	-50.0%
FWH 4C Drain Temp	°F	274.6	231.7	-42.9°F	229.4	-45.2°F
FWH 1A TTD	°F	4.7	4.5	-0.1°F	3.2	-1.5°F
FWH 1A DCA	°F	7.4	7.4	0.0°F	7.4	0.0°F
FWH 2A TTD	°F	5.9	8.3	2.4°F	5.1	-0.7°F
FWH 2A DCA	°F	8.8	6.6	-2.1°F	4.4	-4.4°F
FWH 3A TTD	°F	5.0	5.9	0.9°F	3.3	-1.7°F
FWH 3A DCA	°F	14.3	13.2	-1.0°F	8.8	-5.5°F
FWH 4A TTD	°F	5.6	6.7	1.1°F	3.9	-1.7°F
FWH 4A DCA	°F	10.9	9.7	-1.1°F	5.9	-4.9°F
FWH 5A TTD	°F	5.9	5.8	-0.1°F	8.9	3.0°F
FWH 5A DCA	°F	6.2	2.8	-3.3°F	7.3	1.2°F
FWH 6A TTD	°F	3.9	3.3	-0.6°F	3.9	0.0°F
FWH 6A DCA	°F	4.4	2.3	-2.1°F	2.9	-1.5°F
FWH 7A TTD	°F	6.5	4.9	-1.6°F	5.1	-1.4°F
FWH 7A DCA	°F	7.5	4.2	-3.3°F	4.2	-3.3°F
FWH 1B TTD	°F	3.9	3.9	0.0°F	2.7	-1.3°F
FWH 1B DCA	°F	6.6	6.6	0.0°F	6.6	0.0°F
FWH 2B TTD	°F	3.1	5.7	2.6°F	3.3	0.2°F
FWH 2B DCA	°F	8.5	6.4	-2.1°F	4.2	-4.3°F
FWH 3B TTD	°F	3.1	3.9	0.8°F	2.0	-1.1°F
FWH 3B DCA	°F	12.5	11.6	-0.9°F	7.6	-4.9°F
FWH 4B TTD	°F	3.5	4.5	1.0°F	2.4	-1.1°F
FWH 4B DCA	°F	12.9	11.6	-1.3°F	7.5	-5.4°F
FWH 5B TTD	°F	5.6	5.5	-0.1°F	8.5	2.9°F
FWH 5B DCA	°F	6.1	2.8	-3.3°F	7.5	1.3°F
FWH 6B TTD	°F	3.7	3.1	-0.5°F	3.7	0.0°F
FWH 6B DCA	°F	5.3	2.9	-2.4°F	3.6	-1.7°F
FWH 7B TTD	°F	5.2	3.9	-1.3°F	4.0	-1.2°F
FWH 7B DCA	°F	9.2	5.5	-3.7°F	5.4	-3.8°F
FWH 1C TTD	°F	4.9	4.7	-0.2°F	3.3	-1.6°F
FWH 1C DCA	°F	9.3	9.3	0.0°F	9.3	0.0°F
FWH 2C TTD	°F	3.2	5.9	2.7°F	3.4	0.2°F

Attachment A
PEPSE Modeling for 30%, 50%, and 70% Extraction

Description	Units	0%	50%	Δ (50%)	50% w/ Bypass	Δ (50% w/ Bypass)
FWH 2C DCA	°F	9.1	6.8	-2.2°F	4.6	-4.5°F
FWH 3C TTD	°F	3.6	4.4	0.8°F	2.4	-1.2°F
FWH 3C DCA	°F	13.9	13.0	-0.9°F	8.8	-5.1°F
FWH 4C TTD	°F	5.0	6.0	1.1°F	3.5	-1.5°F
FWH 4C DCA	°F	10.0	8.9	-1.1°F	5.4	-4.5°F
Final FW Temperature	°F	440.9	389.0	-51.9°F	387.1	-53.8°F
Final FW Flow	lbm/hr	16,067,280	14,982,480	-6.8%	14,946,080	-7.0%
Heater Drain Tank Pressure	psia	185.1	101.8	-45.0%	94.7	-48.8%
Heater Drain Tank Temperature	°F	336.6	282.3	-54.3°F	254.7	-81.9°F
FWH 7A Drain Flow	lbm/hr	650,363	498,182	-23.4%	486,957	-25.1%
FWH 7B Drain Flow	lbm/hr	667,282	509,128	-23.7%	498,103	-25.4%
FWH 6A Drain Flow	lbm/hr	1,051,707	816,070	-22.4%	848,117	-19.4%
FWH 6B Drain Flow	lbm/hr	1,066,632	825,343	-22.6%	857,643	-19.6%
DC 5A Drain Flow	lbm/hr	1,698,661	1,311,622	-22.8%	1,504,578	-11.4%
DC 5B Drain Flow	lbm/hr	1,709,462	1,316,953	-23.0%	1,515,494	-11.3%
FWH 4A Drain Flow	lbm/hr	202,828	190,532	-6.1%	141,487	-30.2%
FWH 4B Drain Flow	lbm/hr	204,306	191,817	-6.1%	142,155	-30.4%
FWH 4C Drain Flow	lbm/hr	199,621	187,309	-6.2%	139,798	-30.0%
FWH 3A Drain Flow	lbm/hr	401,346	380,209	-5.3%	283,566	-29.3%
FWH 3B Drain Flow	lbm/hr	399,431	379,871	-4.9%	282,648	-29.2%
FWH 3C Drain Flow	lbm/hr	394,844	375,580	-4.9%	280,544	-28.9%
FWH 2A Drain Flow	lbm/hr	598,008	536,820	-10.2%	409,174	-31.6%
FWH 2B Drain Flow	lbm/hr	604,648	542,836	-10.2%	411,325	-32.0%
FWH 2C Drain Flow	lbm/hr	602,457	541,727	-10.1%	411,600	-31.7%
DC 1A Drain Flow	lbm/hr	817,619	670,424	-18.0%	522,171	-36.1%
DC 1B Drain Flow	lbm/hr	825,705	676,903	-18.0%	524,639	-36.5%
DC 1C Drain Flow	lbm/hr	822,307	675,387	-17.9%	524,975	-36.2%

Table A6.6: Condenser Impacts – 50% Thermal Extraction

Description	Units	0%	50%	Δ (50%)	50% w/ Bypass	Δ (50% w/ Bypass)
Condenser A Shell Pressure	psia	1.24	0.87	-29.6%	0.88	-29.5%
Condenser B Shell Pressure	psia	1.38	0.90	-34.9%	0.90	-34.5%
Condenser C Shell Pressure	psia	1.64	0.99	-39.7%	1.00	-39.4%
CW Inlet Temperature	°F	83.3	83.3	0.0°F	83.3	0.0°F
CW Outlet Temperature	°F	105.6	94.7	-10.9°F	94.8	-10.8°F

Attachment A
PEPSE Modeling for 30%, 50%, and 70% Extraction

Table A6.7: Pump Impacts – 50% Thermal Extraction

Description	Units	0%	50%	Δ (50%)	50% w/ Bypass	Δ (50% w/ Bypass)
Condensate Pumps dP	psid	139.9	140.5	0.5%	140.5	0.5%
Condensate Booster Pumps dP	psid	398.5	398.5	0.0%	398.5	0.0%
Condensate Flow	lbm/hr	11,334,490	11,889,450	4.9%	11,475,500	1.2%
FWP A Flow	lbm/hr	8,033,640	7,491,242	-6.8%	7,473,038	-7.0%
FWP A dP	psid	659.4	668.9	1.4%	638.7	-3.1%
FWPT A Steam Flow	lbm/hr	130,855	134,299	2.6%	129,435	-1.1%
FWPT A Inlet Pressure	psia	173.9	95.6	-45.0%	89.2	-48.7%
FWPT A Inlet Enthalpy	BTU/lbm	1,273.9	1290.5	1.3%	1,292.0	1.4%
FWP B Flow	lbm/hr	8,033,640	7,491,242	-6.8%	7,473,038	-7.0%
FWP B dP	psid	659.4	668.9	1.4%	638.7	-3.1%
FWPT B Steam Flow	lbm/hr	130,855	134,299	2.6%	129,435	-1.1%
FWPT B Inlet Pressure	psia	173.9	95.6	-45.0%	89.2	-48.7%
FWPT B Inlet Enthalpy	BTU/lbm	1,273.9	1290.5	1.3%	1,292	1.4%

A7 Results of 70% Thermal Extraction

Tables A7.1-A7.7 compare important operating parameters within the nuclear power cycle to determine possible significant impact to station equipment for 70% thermal extraction. The PEPSE diagrams (located at the end of the Attachment A) show the results for this case.

Table A7.1: General Impacts – 70% Thermal Extraction

Description	Units	0%	70%	Δ (70%)
Generator Electric Power	MWe	1,228.0	327.3	-73.3%
Thermal Power Extracted	MWt	0	2,557	-
% of Flow - MS	%	0	55.0	-
MS Flow	lbm/hr	16,037,390	14,316,180	-10.7%
HP Turbine Inlet Flow	lbm/hr	15,218,400	5,893,152	-61.3%
HP Turbine First Stage Pressure	psia	651.5	260.4	-60.0%
MSR Inlet Pressure	psia	190.3	65.5	-65.6%
LP Turbine Inlet Flow	lbm/hr	3,673,069	1,230,440	-66.5%
LP Turbine Inlet Pressure	psia	175.5	60.4	-65.6%
Condenser Duty	BTU/hr	8.21E+09	2.57E+09	-68.7%
Condensate Pump Flow	lbm/hr	11,334,490	11,900,900	5.0%
Heater Drain Pump Flow	lbm/hr	4,732,792	2,445,181	-48.3%
Feedwater Pump Flow	lbm/hr	16,067,280	14,346,080	-10.7%
Final Feedwater Temperature	°F	440.9	354.0	-86.9°F
Cascading Drain Flow to Condenser	lbm/hr	817,619	542,768	-33.6%

Attachment A
PEPSE Modeling for 30%, 50%, and 70% Extraction

Description	Units	0%	70%	Δ (70%)
Cogen HX Inlet Mass Flow	lbm/hr	-	7,878,196	-
Cogen HX Inlet Pressure	psia	-	817.3	-
Cogen HX Inlet Temperature	°F	-	520.7	-
Cogen HX Inlet Enthalpy	BTU/lbm	-	1,197.3	-
Cogen HX Outlet Temperature	°F	-	120.0	-
Cogen HX Outlet Enthalpy	BTU/lbm	-	90.1	-

Table A7.2: MSR Impacts – 70% Thermal Extraction

Description	Units	0%	70%	Δ (70%)
MSR A Removal Effectiveness	-	95.0%	0.95	0.0%
MSR A Chevrans Inlet Flow	lbm/hr	3,151,396	1,048,748	-66.7%
MSR A Chevrans Inlet Enthalpy	BTU/lbm	1,104.0	1,128.6	2.2%
MSR A Chevrans Inlet Pressure	psia	190.3	65.5	-65.6%
MSR A 1 st Stage Inlet Enthalpy	BTU/lbm	1,192.7	1,176.7	-1.3%
MSR A 1 st Stage Inlet Pressure	psia	184.6	63.5	-65.6%
MSR A 2 nd Stage Inlet Enthalpy	BTU/lbm	1,226.8	1,209.5	-1.4%
MSR A 2 nd Stage Inlet Pressure	psia	181.8	62.5	-65.6%
MSR B Removal Effectiveness	-	95.0%	0.95	0.0%
MSR B Chevrans Inlet Flow	lbm/hr	3,151,396	1,048,748	-66.7%
MSR B Chevrans Inlet Enthalpy	BTU/lbm	1,104.0	1,128.6	2.2%
MSR B Chevrans Inlet Pressure	psia	190.3	65.5	-65.6%
MSR B 1 st Stage Inlet Enthalpy	BTU/lbm	1,192.7	1,176.7	-1.3%
MSR B 1 st Stage Inlet Pressure	psia	184.6	63.5	-65.6%
MSR B 2 nd Stage Inlet Enthalpy	BTU/lbm	1,226.8	1,209.5	-1.4%
MSR B 2 nd Stage Inlet Pressure	psia	181.8	62.5	-65.6%
MSR C Removal Effectiveness	-	95.0%	1.0	0.0%
MSR C Chevrans Inlet Flow	lbm/hr	3,151,396	1,048,748	-66.7%
MSR C Chevrans Inlet Enthalpy	BTU/lbm	1,104.0	1,128.6	2.2%
MSR C Chevrans Inlet Pressure	psia	190.3	65.5	-65.6%
MSR C 1 st Stage Inlet Enthalpy	BTU/lbm	1,192.7	1,176.7	-1.3%
MSR C 1 st Stage Inlet Pressure	psia	184.6	63.5	-65.6%
MSR C 2 nd Stage Inlet Enthalpy	BTU/lbm	1,226.8	1,209.5	-1.4%
MSR C 2 nd Stage Inlet Pressure	psia	181.8	62.5	-65.6%
MSR D Removal Effectiveness	-	95.0%	1.0	0.0%
MSR D Chevrans Inlet Flow	lbm/hr	3,151,396	1,048,748	-66.7%
MSR D Chevrans Inlet Enthalpy	BTU/lbm	1,104.0	1,128.6	2.2%
MSR D Chevrans Inlet Pressure	psia	190.3	65.5	-65.6%
MSR D 1 st Stage Inlet Enthalpy	BTU/lbm	1,192.7	1,176.7	-1.3%

Attachment A
PEPSE Modeling for 30%, 50%, and 70% Extraction

Description	Units	0%	70%	Δ (70%)
MSR D 1 st Stage Inlet Pressure	psia	184.6	63.5	-65.6%
MSR D 2 nd Stage Inlet Enthalpy	BTU/lbm	1,226.8	1,209.5	-1.4%
MSR D 2nd Stage Inlet Pressure	psia	181.8	62.5	-65.6%

Table A7.3: MSR Drain Impacts – 70% Thermal Extraction

Description	Units	0%	70%	Δ (70%)
MSDT A Drain Flow	lbm/hr	331,167	55,451	-83.3%
MSDT A Drain Enthalpy	BTU/lbm	348.4	266.0	-23.6%
MSDT A Drain Pressure	psia	184.6	63.5	-65.6%
MSDT A Drain Temperature	°F	375.1	296.4	-78.7°F
RH1 A Drain Flow	lbm/hr	135,811	39,071	-71.2%
RH1 A Drain Enthalpy	BTU/lbm	451.2	360.0	-20.2%
RH1 A Drain Pressure	psia	444.2	173.4	-61.0%
RH1 A Drain Temperature	°F	455.0	370.0	-85°F
RH2 A Drain Flow	lbm/hr	200,587	131,899	-34.2%
RH2 A Drain Enthalpy	BTU/lbm	534.5	536.6	0.4%
RH2 A Drain Pressure	psia	865.1	878.3	1.5%
RH2 A Drain Temperature	°F	527.3	529.1	1.8°F
MSDT B Drain Flow	lbm/hr	331,167	55,451	-83.3%
MSDT B Drain Enthalpy	BTU/lbm	348.4	266.0	-23.6%
MSDT B Drain Pressure	psia	184.6	63.5	-65.6%
MSDT B Drain Temperature	°F	375.1	296.4	-78.7°F
RH1 B Drain Flow	lbm/hr	135,811	39,071	-71.2%
RH1 B Drain Enthalpy	BTU/lbm	451.2	360.0	-20.2%
RH1 B Drain Pressure	psia	444.2	173.4	-61.0%
RH1 B Drain Temperature	°F	455.0	370.0	-85°F
RH2 B Drain Flow	lbm/hr	200,731	132,064	-34.2%
RH2 B Drain Enthalpy	BTU/lbm	535.2	536.9	0.3%
RH2 B Drain Pressure	psia	869.3	880.1	1.2%
RH2 B Drain Temperature	°F	527.9	529.3	1.5°F
MSDT C Drain Flow	lbm/hr	331,167	55,451	-83.3%
MSDT C Drain Enthalpy	BTU/lbm	348.4	266.0	-23.6%
MSDT C Drain Pressure	psia	184.6	63.5	-65.6%
MSDT C Drain Temperature	°F	375.1	296.4	-78.7°F
RH1 C Drain Flow	lbm/hr	135,811	39,071	-71.2%
RH1 C Drain Enthalpy	BTU/lbm	451.2	360.0	-20.2%
RH1 C Drain Pressure	psia	444.2	173.4	-61.0%
RH1 C Drain Temperature	°F	455.0	370.0	-85°F

Attachment A
PEPSE Modeling for 30%, 50%, and 70% Extraction

Description	Units	0%	70%	Δ (70%)
RH2 C Drain Flow	lbm/hr	200,371	131,742	-34.3%
RH2 C Drain Enthalpy	BTU/lbm	533.9	536.3	0.5%
RH2 C Drain Pressure	psia	861.3	876.7	1.8%
RH2 C Drain Temperature	°F	526.8	528.9	2.1°F
MSDT D Drain Flow	lbm/hr	331,167	55,451	-83.3%
MSDT D Drain Enthalpy	BTU/lbm	348.4	266.0	-23.6%
MSDT D Drain Pressure	psia	184.6	63.5	-65.6%
MSDT D Drain Temperature	°F	375.1	296.4	-78.7°F
RH1 D Drain Flow	lbm/hr	135,811	39,071	-71.2%
RH1 D Drain Enthalpy	BTU/lbm	451.2	360.0	-20.2%
RH1 D Drain Pressure	psia	444.2	173.4	-61.0%
RH1 D Drain Temperature	°F	455.0	370.0	-85°F
RH2 D Drain Flow	lbm/hr	200,264	131,724	-34.2%
RH2 D Drain Enthalpy	BTU/lbm	533.8	536.3	0.5%
RH2 D Drain Pressure	psia	861.0	876.6	1.8%
RH2 D Drain Temperature	°F	526.7	528.8	2.1°F

Table A7.4: Turbine Impacts – 70% Thermal Extraction

Description	Units	0%	70%	Δ (70%)
MSR to LPT A Flow	lbm/hr	3,673,069	1,230,440	-66.5%
MSR to LPT A Enthalpy	BTU/lbm	1,273.9	1,297.2	1.8%
LPT A Inlet Pressure	psia	175.5	60.4	-65.6%
LPT A Inlet Temperature	°F	504.2	528.6	24.4°F
MSR to LPT B Flow	lbm/hr	3,673,069	1,230,440	-66.5%
MSR to LPT B Enthalpy	BTU/lbm	1,273.9	1,297.2	1.8%
LPT B Inlet Pressure	psia	175.7	60.4	-65.6%
LPT B Inlet Temperature	°F	504.2	528.6	24.3°F
MSR to LPT C Flow	lbm/hr	3,673,069	1,230,440	-66.5%
MSR to LPT C Enthalpy	BTU/lbm	1,273.9	1,297.2	1.8%
LPT C Inlet Pressure	psia	175.7	60.4	-65.6%
LPT C Inlet Temperature	°F	504.2	528.6	24.3°F
HPT to 7th Stage FWHs Flow	lbm/hr	515,692	247,885	-51.9%
HPT to 7th Stage FWHs Enthalpy	BTU/lbm	1,144.6	1,190.0	4.0%
HPT to 7th Stage FWHs Pressure	psia	408.7	148.7	-63.6%
HPT to 6th Stage FWHs Flow	lbm/hr	800,695	576,483	-28.0%
HPT to 6th Stage FWHs Enthalpy	BTU/lbm	1,114.2	1,156.7	3.8%
HPT to 6th Stage FWHs Pressure	psia	287.1	105.3	-63.3%
HPT to 5th Stage FWHs Flow	lbm/hr	746,538	715,294	-4.2%

Attachment A
PEPSE Modeling for 30%, 50%, and 70% Extraction

Description	Units	0%	70%	Δ (70%)
HPT to 5th Stage FWHs Enthalpy	BTU/lbm	1,104.0	1,128.6	2.2%
HPT to 5th Stage FWHs Pressure	psia	186.1	64.0	-65.6%
LPT A to FWH 1A Flow	lbm/hr	219,611	64,887	-70.5%
LPT A to FWH 1A Enthalpy	BTU/lbm	729.4	836.4	14.7%
LPT A to FWH 1A Pressure	psia	5.43	1.3	-76.8%
LPT A to FWH 2A Flow	lbm/hr	196,662	116,204	-40.9%
LPT A to FWH 2A Enthalpy	BTU/lbm	969.8	1,053.3	8.6%
LPT A to FWH 2A Pressure	psia	15.91	3.8	-76.4%
LPT A to FWH 3A Flow	lbm/hr	198,518	181,205	-8.7%
LPT A to FWH 3A Enthalpy	BTU/lbm	1,158.7	1,157.3	-0.1%
LPT A to FWH 3A Pressure	psia	40.6	10.6	-73.9%
LPT A to FWH 4A Flow	lbm/hr	202,828	180,472	-11.0%
LPT A to FWH 4A Enthalpy	BTU/lbm	1,219.2	1,229.8	0.9%
LPT A to FWH 4A Pressure	psia	89.5	27.5	-69.3%
LPT B to FWH 1B Flow	lbm/hr	221,057	64,175	-71.0%
LPT B to FWH 1B Enthalpy	BTU/lbm	730.6	838.8	14.8%
LPT B to FWH 1B Pressure	psia	5.41	1.2	-77.0%
LPT B to FWH 2B Flow	lbm/hr	205,217	120,304	-41.4%
LPT B to FWH 2B Enthalpy	BTU/lbm	972.9	1,061.1	9.1%
LPT B to FWH 2B Pressure	psia	15.87	3.7	-76.6%
LPT B to FWH 3B Flow	lbm/hr	195,125	182,651	-6.4%
LPT B to FWH 3B Enthalpy	BTU/lbm	1,158.7	1,157.0	-0.1%
LPT B to FWH 3B Pressure	psia	40.6	10.5	-74.0%
LPT B to FWH 4B Flow	lbm/hr	204,306	182,293	-10.8%
LPT B to FWH 4B Enthalpy	BTU/lbm	1,219.1	1,229.5	0.9%
LPT B to FWH 4B Pressure	psia	89.5	27.4	-69.4%
LPT C to FWH 1C Flow	lbm/hr	219,850	64,708	-70.6%
LPT C to FWH 1C Enthalpy	BTU/lbm	729.7	836.0	14.6%
LPT C to FWH 1C Pressure	psia	5.42	1.3	-76.9%
LPT C to FWH 2C Flow	lbm/hr	207,613	122,013	-41.2%
LPT C to FWH 2C Enthalpy	BTU/lbm	976.3	1,054.6	8.0%
LPT C to FWH 2C Pressure	psia	15.88	3.7	-76.5%
LPT C to FWH 3C Flow	lbm/hr	195,223	182,602	-6.5%
LPT C to FWH 3C Enthalpy	BTU/lbm	1,158.8	1,157.3	-0.1%
LPT C to FWH 3C Pressure	psia	40.6	10.6	-73.9%
LPT C to FWH 4C Flow	lbm/hr	199,621	178,037	-10.8%
LPT C to FWH 4C Enthalpy	BTU/lbm	1,219.2	1,229.9	0.9%
LPT C to FWH 4C Pressure	psia	89.6	27.5	-69.3%

Attachment A
PEPSE Modeling for 30%, 50%, and 70% Extraction

Table A7.5: Feedwater Heater Impacts – 70% Thermal Extraction

Description	Units	0%	70%	Δ (70%)
DC 1A Discharge Temp	°F	126.3	94.5	-31.8°F
FWH 1A Discharge Temp	°F	161.1	107.1	-54°F
FWH 1A Extraction Pressure	psia	5.43	1.3	-76.8%
FWH 1A Drain Temp	°F	165.3	109.0	-56.3 °F
FWH 2A Discharge Temp	°F	210.1	139.4	-70.7°F
FWH 2A Extraction Pressure	psia	15.91	3.8	-76.4%
FWH 2A Drain Temp	°F	169.8	111.6	-58.2°F
FWH 3A Discharge Temp	°F	263.1	189.0	-74.1°F
FWH 3A Extraction Pressure	psia	40.6	10.6	-73.9%
FWH 3A Drain Temp	°F	224.4	152.3	-72.1°F
FWH 4A Discharge Temp	°F	314.3	237.1	-77.2°F
FWH 4A Extraction Pressure	psia	89.5	27.5	-69.3%
FWH 4A Drain Temp	°F	274.0	198.2	-75.8°F
DC 5A Discharge Temp	°F	331.4	248.4	-83°F
FWH 5A Discharge Temp	°F	369.9	291.0	-78.9°F
FWH 5A Extraction Pressure	psia	186.1	64.0	-65.6%
FWH 5A Drain Temp	°F	375.8	296.8	-79°F
FWH 6A Discharge Temp	°F	409.5	328.2	-81.3°F
FWH 6A Extraction Pressure	psia	287.1	105.3	-63.3%
FWH 6A Drain Temp	°F	374.3	292.4	-82°F
FWH 7A Discharge Temp	°F	440.2	353.5	-86.7°F
FWH 7A Extraction Pressure	psia	408.7	148.7	-63.6%
FWH 7A Drain Temp	°F	420.2	333.4	-86.8°F
DC 1B Discharge Temp	°F	126.6	94.7	-32°F
FWH 1B Discharge Temp	°F	161.7	107.1	-54.6°F
FWH 1B Extraction Pressure	psia	5.41	1.2	-77.0%
FWH 1B Drain Temp	°F	165.1	108.6	-56.5°F
FWH 2B Discharge Temp	°F	212.8	140.8	-72°F
FWH 2B Extraction Pressure	psia	15.87	3.7	-76.6%
FWH 2B Drain Temp	°F	170.2	111.4	-58.7°F
FWH 3B Discharge Temp	°F	265.0	190.8	-74.2°F
FWH 3B Extraction Pressure	psia	40.6	10.5	-74.0%
FWH 3B Drain Temp	°F	225.3	152.3	-72.9°F
FWH 4B Discharge Temp	°F	316.4	239.2	-77.2°F
FWH 4B Extraction Pressure	psia	89.5	27.4	-69.4%
FWH 4B Drain Temp	°F	277.9	201.9	-76°F
DC 5B Discharge Temp	°F	332.2	249.3	-82.9°F

Attachment A
PEPSE Modeling for 30%, 50%, and 70% Extraction

Description	Units	0%	70%	Δ (70%)
FWH 5B Discharge Temp	°F	370.2	291.3	-78.9°F
FWH 5B Extraction Pressure	psia	186.1	64.0	-65.6%
FWH 5B Drain Temp	°F	375.8	296.8	-79°F
FWH 6B Discharge Temp	°F	409.7	328.4	-81.3°F
FWH 6B Extraction Pressure	psia	287.1	105.3	-63.3%
FWH 6B Drain Temp	°F	375.5	293.1	-82.4°F
FWH 7B Discharge Temp	°F	441.5	354.4	-87.1°F
FWH 7B Extraction Pressure	psia	408.7	148.7	-63.6%
FWH 7B Drain Temp	°F	421.9	334.2	-87.6°F
DC 1C Discharge Temp	°F	125.9	94.3	-31.7°F
FWH 1C Discharge Temp	°F	160.8	106.8	-54°F
FWH 1C Extraction Pressure	psia	5.42	1.3	-76.9%
FWH 1C Drain Temp	°F	165.2	108.7	-56.5°F
FWH 2C Discharge Temp	°F	212.7	140.7	-72°F
FWH 2C Extraction Pressure	psia	15.88	3.7	-76.5%
FWH 2C Drain Temp	°F	169.9	111.4	-58.5°F
FWH 3C Discharge Temp	°F	264.6	190.5	-74.1°F
FWH 3C Extraction Pressure	psia	40.6	10.6	-73.9%
FWH 3C Drain Temp	°F	226.6	153.7	-72.9°F
FWH 4C Discharge Temp	°F	315.0	237.9	-77.1°F
FWH 4C Extraction Pressure	psia	89.6	27.5	-69.3%
FWH 4C Drain Temp	°F	274.6	198.9	-75.7°F
FWH 1A TTD	°F	4.7	2.5	-2.2°F
FWH 1A DCA	°F	7.4	7.4	0°F
FWH 2A TTD	°F	5.9	10.9	5.1°F
FWH 2A DCA	°F	8.8	4.5	-4.2°F
FWH 3A TTD	°F	5.0	7.0	2°F
FWH 3A DCA	°F	14.3	12.8	-1.5°F
FWH 4A TTD	°F	5.6	8.2	2.7°F
FWH 4A DCA	°F	10.9	9.2	-1.7°F
FWH 5A TTD	°F	5.9	6.0	0.1°F
FWH 5A DCA	°F	6.2	1.5	-4.7°F
FWH 6A TTD	°F	3.9	3.4	-0.5°F
FWH 6A DCA	°F	4.4	1.4	-3°F
FWH 7A TTD	°F	6.5	4.2	-2.3°F
FWH 7A DCA	°F	7.5	2.3	-5.2°F
FWH 1B TTD	°F	3.9	2.1	-1.8°F
FWH 1B DCA	°F	6.6	6.6	0°F

Attachment A
PEPSE Modeling for 30%, 50%, and 70% Extraction

Description	Units	0%	70%	Δ (70%)
FWH 2B TTD	°F	3.1	9.2	6.1°F
FWH 2B DCA	°F	8.5	4.4	-4.1°F
FWH 3B TTD	°F	3.1	4.9	1.8°F
FWH 3B DCA	°F	12.5	11.6	-0.9°F
FWH 4B TTD	°F	3.5	6.0	2.5°F
FWH 4B DCA	°F	12.9	11.1	-1.8°F
FWH 5B TTD	°F	5.6	5.7	0.1°F
FWH 5B DCA	°F	6.1	1.5	-4.7°F
FWH 6B TTD	°F	3.7	3.2	-0.5°F
FWH 6B DCA	°F	5.3	1.8	-3.5°F
FWH 7B TTD	°F	5.2	3.3	-1.9°F
FWH 7B DCA	°F	9.2	3.2	-6°F
FWH 1C TTD	°F	4.9	2.6	-2.3°F
FWH 1C DCA	°F	9.3	9.3	0°F
FWH 2C TTD	°F	3.2	9.4	6.2°F
FWH 2C DCA	°F	9.1	4.6	-4.4°F
FWH 3C TTD	°F	3.6	5.5	1.9°F
FWH 3C DCA	°F	13.9	12.9	-0.9°F
FWH 4C TTD	°F	5.0	7.5	2.5°F
FWH 4C DCA	°F	10.0	8.4	-1.5°F
Final FW Temperature	°F	440.9	354.0	-86.9°F
Final FW Flow	lbm/hr	16,067,280	14,346,080	-10.7%
Heater Drain Tank Pressure	psia	185.1	63.7	-65.6%
Heater Drain Tank Temperature	°F	336.6	244.7	-91.8°F
FWH 7A Drain Flow	lbm/hr	650,363	383,540	-41.0%
FWH 7B Drain Flow	lbm/hr	667,282	391,774	-41.3%
FWH 6A Drain Flow	lbm/hr	1,051,707	672,514	-36.1%
FWH 6B Drain Flow	lbm/hr	1,066,632	679,283	-36.3%
DC 5A Drain Flow	lbm/hr	1,698,661	1,110,117	-34.6%
DC 5B Drain Flow	lbm/hr	1,709,462	1,113,258	-34.9%
FWH 4A Drain Flow	lbm/hr	202,828	180,472	-11.0%
FWH 4B Drain Flow	lbm/hr	204,306	182,293	-10.8%
FWH 4C Drain Flow	lbm/hr	199,621	178,037	-10.8%
FWH 3A Drain Flow	lbm/hr	401,346	361,677	-9.9%
FWH 3B Drain Flow	lbm/hr	399,431	364,944	-8.6%
FWH 3C Drain Flow	lbm/hr	394,844	360,639	-8.7%
FWH 2A Drain Flow	lbm/hr	598,008	477,881	-20.1%
FWH 2B Drain Flow	lbm/hr	604,648	485,248	-19.7%

Attachment A
PEPSE Modeling for 30%, 50%, and 70% Extraction

Description	Units	0%	70%	Δ (70%)
FWH 2C Drain Flow	lbm/hr	602,457	482,651	-19.9%
DC 1A Drain Flow	lbm/hr	817,619	542,768	-33.6%
DC 1B Drain Flow	lbm/hr	825,705	549,423	-33.5%
DC 1C Drain Flow	lbm/hr	822,307	547,360	-33.4%

Table A7.6: Condenser Impacts – 70% Thermal Extraction

Description	Units	0%	70%	Δ (70%)
Condenser A Shell Pressure	psia	1.242	0.760	-38.8%
Condenser B Shell Pressure	psia	1.381	0.778	-43.6%
Condenser C Shell Pressure	psia	1.642	0.826	-49.7%
CW Inlet Temperature	°F	83.3	83.3	0.0°F
CW Outlet Temperature	°F	105.6	90.3	-15.3°F

Table A7.7: Pump Impacts – 70% Thermal Extraction

Description	Units	0%	70%	Δ (70%)
Condensate Pumps dP	psid	139.9	140.7	0.6%
Condensate Booster Pumps dP	psid	398.5	398.5	0.0%
Condensate Flow	lbm/hr	11,334,490	11,900,900	5.0%
FWP A Flow	lbm/hr	8,033,640	7,173,042	-10.7%
FWP A dP	psid	659.4	672.4	2.0%
FWPT A Steam Flow	lbm/hr	130,855	140,934	7.7%
FWPT A Inlet Pressure	psia	173.9	59.8	-65.6%
FWPT A Inlet Enthalpy	BTU/lbm	1,273.9	1,297.2	1.8%
FWP B Flow	lbm/hr	8,033,640	7,173,042	-10.7%
FWP B dP	psid	659.4	672.4	2.0%
FWPT B Steam Flow	lbm/hr	130,855	140,934	7.7%
FWPT B Inlet Pressure	psia	173.9	59.8	-65.6%
FWPT B Inlet Enthalpy	BTU/lbm	1,273.9	1,297	1.8%

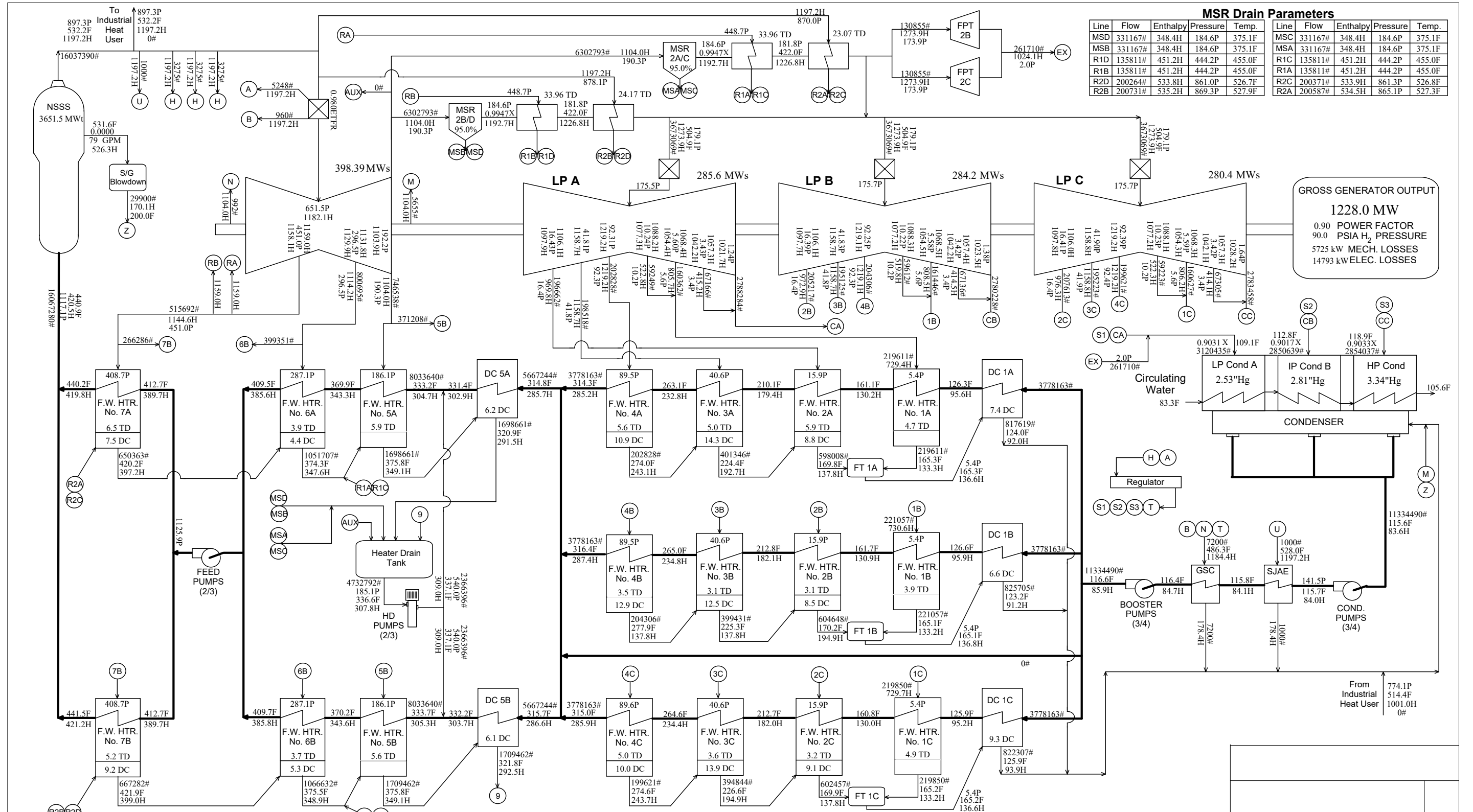

MSR Drain Parameters

Line	Flow	Enthalpy	Pressure	Temp.
MSD	331167#	348.4H	184.6P	375.1F
MSB	331167#	348.4H	184.6P	375.1F
R1D	135811#	451.2H	444.2P	455.0F
R1B	135811#	451.2H	444.2P	455.0F
R2D	200264#	533.8H	861.0P	526.7F
R2B	200731#	535.2H	869.3P	527.9F

GROSS GENERATOR OUTPUT
1228.0 MW
0.90 POWER FACTOR
90.0 PSIA H₂ PRESSURE
5725 kW MECH. LOSSES
14793 kW ELEC. LOSSES

- Notes:
1. Flows are schematic only and may represent two or more parallel paths.
 2. FW heater vent flows are not modeled.
 3. 1st and 2nd stage reheater scavenging steam is not modeled.
 4. ETFR is estimated based on the thermal kit, and not benchmarked.
 5. Generator p.f. is used to compute var losses. It should not be used for electrical system evaluations.
 6. MSR reheat and heating steam P, T, & H shown for the 'B,' 'C' vessels as representative.

Gross Power:	1228.0 MW	Baseline (0% Thermal Extraction)
NSSS Power:	3651.5 MWt	
Gross HR:	10146B/kWh	
P - Pressure, psia	MW - Megawatts	Prepared by: Gabriel Neimark
F - Temperature, F	MWs - Megawatts Shaft Power	
# - Flow Rate, lbm/hr	MWt - Megawatts Thermal	Reviewed by: Nic Richards
× - Quality		

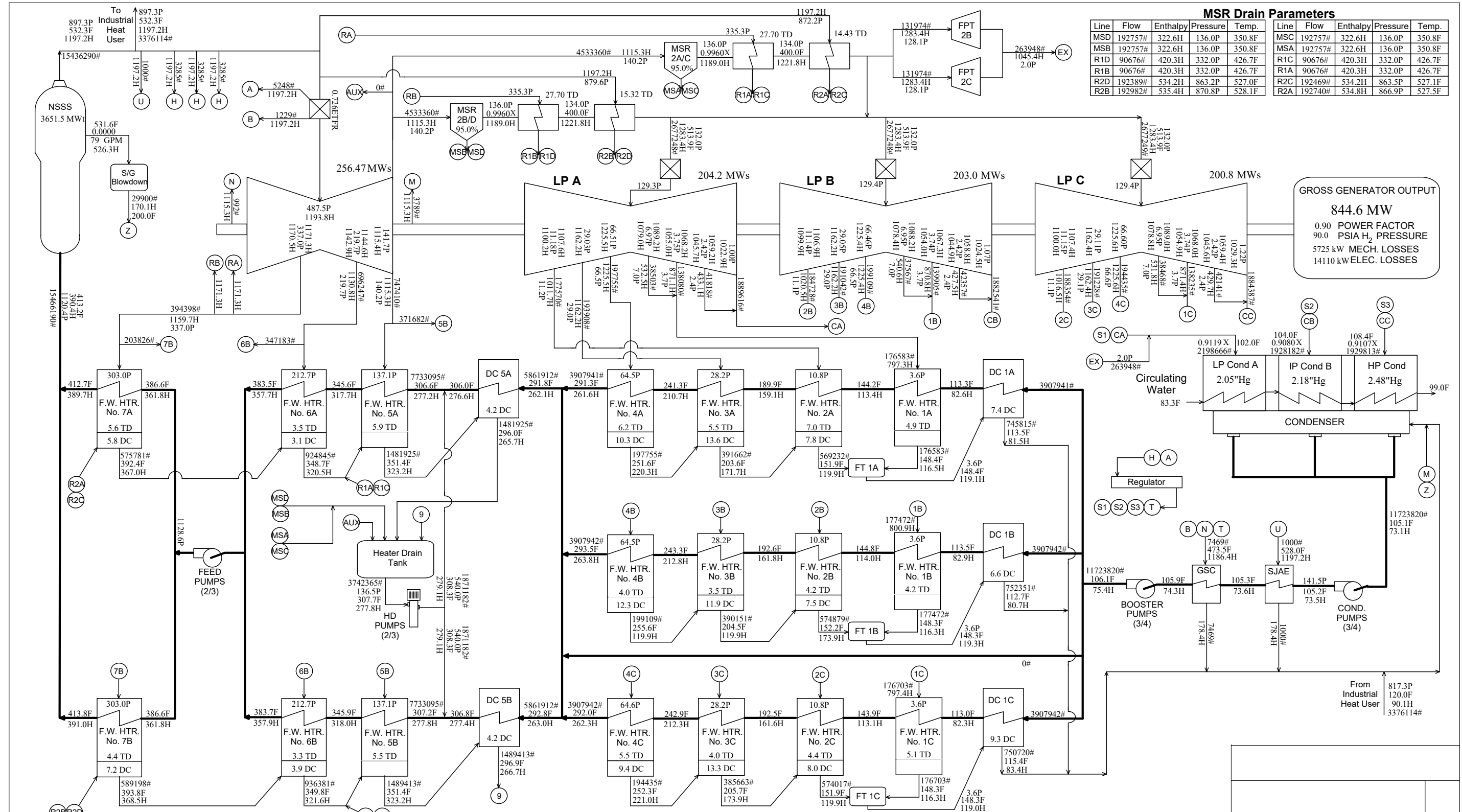

MSR Drain Parameters

Line	Flow	Enthalpy	Pressure	Temp.
MSD	192757#	322.6H	136.0P	350.8F
MSB	192757#	322.6H	136.0P	350.8F
R1D	90676#	420.3H	332.0P	426.7F
R1B	90676#	420.3H	332.0P	426.7F
R2D	192389#	534.2H	863.2P	527.0F
R2B	192982#	535.4H	870.8P	528.1F

GROSS GENERATOR OUTPUT
844.6 MW
 0.90 POWER FACTOR
 90.0 PSIA H₂ PRESSURE
 5725 kW MECH. LOSSES
 14110 kW ELEC. LOSSES

- Notes:
1. Flows are schematic only and may represent two or more parallel paths.
 2. FW heater vent flows are not modeled.
 3. 1st and 2nd stage reheater scavenging steam is not modeled.
 4. ETFR is estimated based on the thermal kit, and not benchmarked.
 5. Generator p.f. is used to compute var losses. It should not be used for electrical system evaluations.
 6. MSR reheat and heating steam P, T, & H shown for the 'B,' 'C' vessels as representative.

Gross Power:	844.6 MW	30% Extraction	
NSSS Power:	3651.5 MWt		
Gross HR:	14751B/kWh		
P - Pressure, psia	MW - Megawatts	Prepared by: Gabriel Neimark	
F - Temperature, F	MWs - Megawatts Shaft Power		Date: 10/26/23
# - Flow Rate, lbm/hr	MWt - Megawatts Thermal		Reviewed by: Nic Richards
× - Quality			Date: 10/26/23

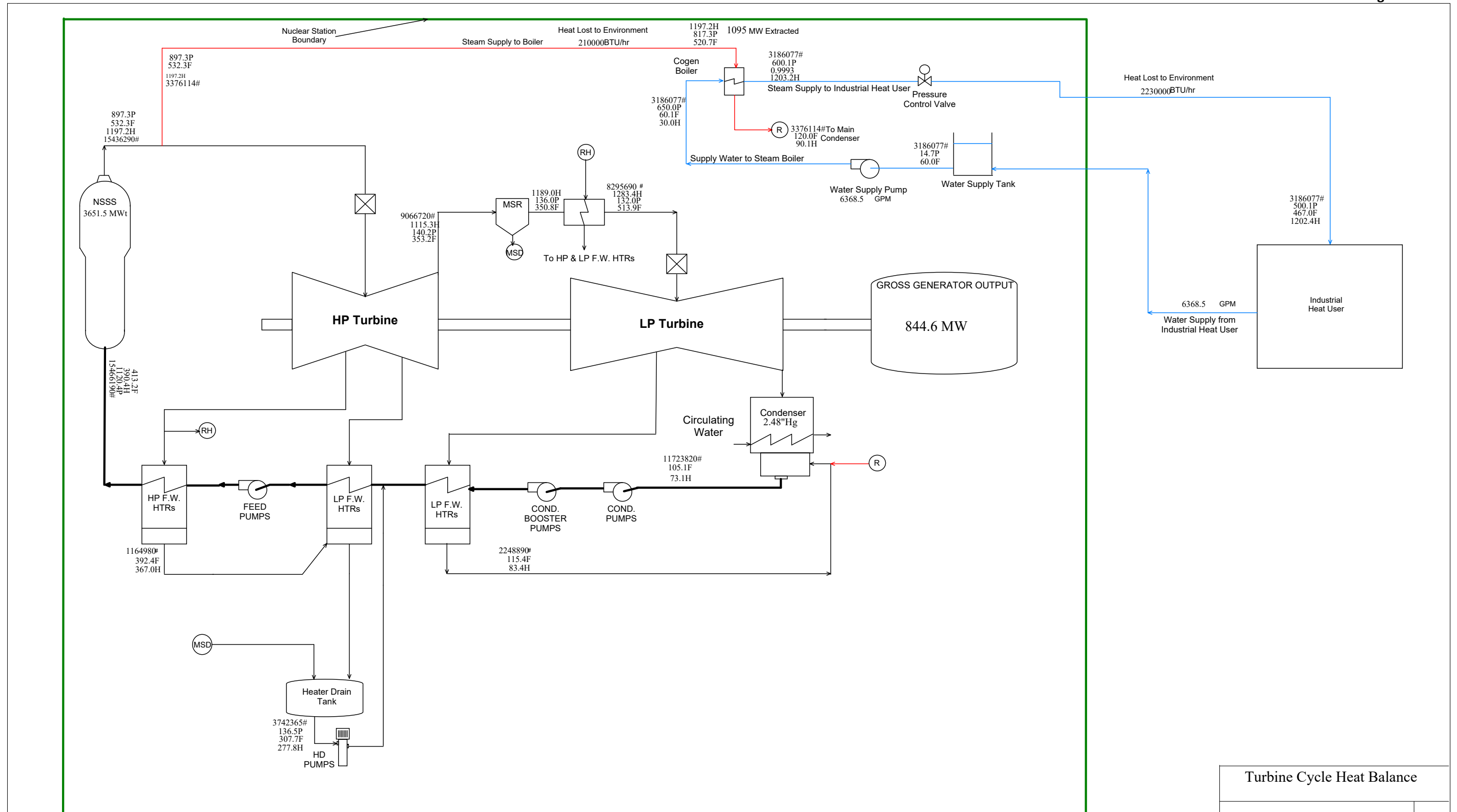

Turbine Cycle Heat Balance	

30% Extraction	
P - Pressure, psia	MW - Megawatts
F - Temperature, F	MWs - Megawatts Shaft Power
H - Enthalpy, Btu/lbm	MWt - Megawatts Thermal
# - Flow Rate, lbm/hr	
× - Quality	
Prepared by: Gabriel Neimark	Date: 10/26/23
Reviewed by: Nic Richards	Date: 10/26/23

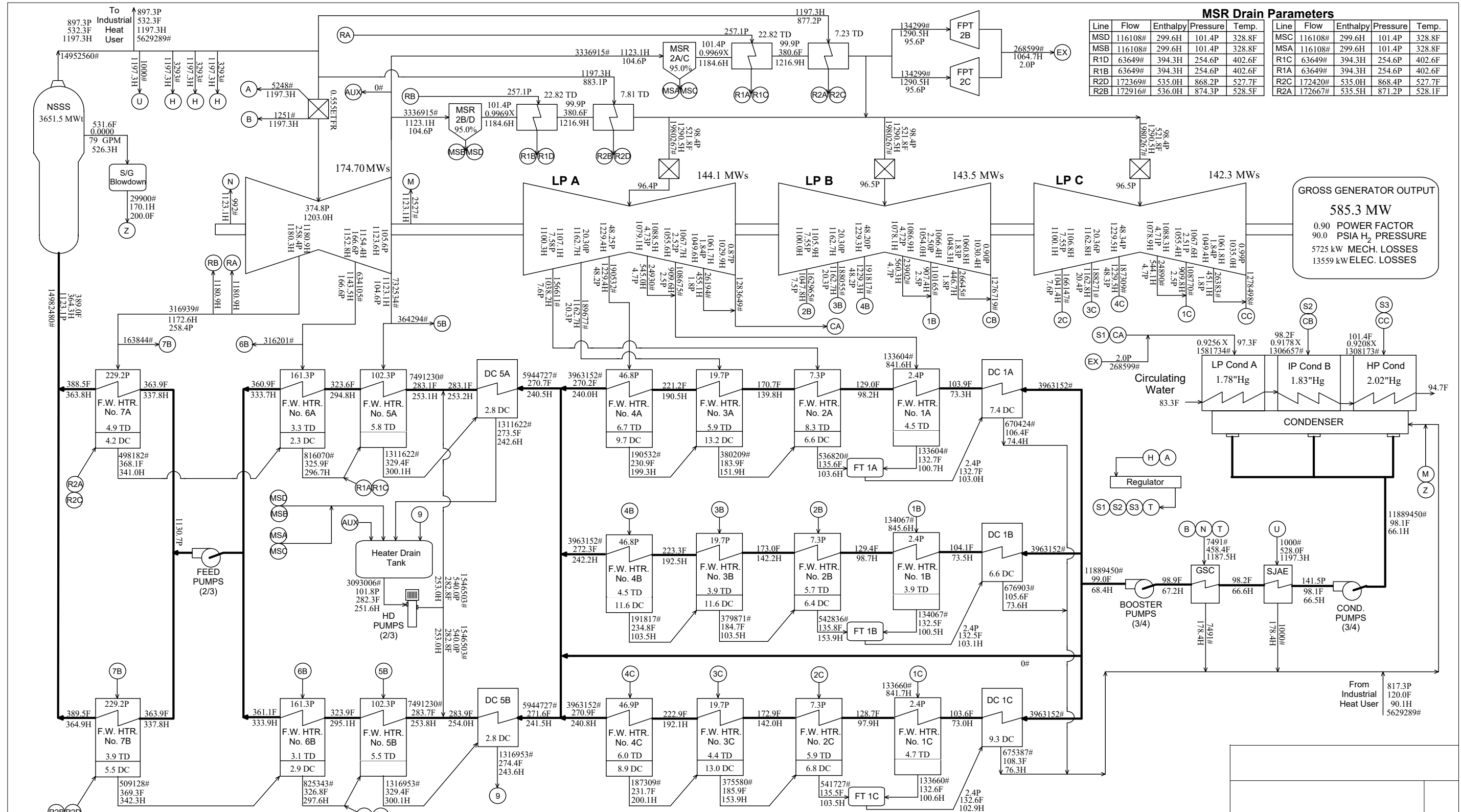

MSR Drain Parameters

Line	Flow	Enthalpy	Pressure	Temp.
MSD	116108#	299.6H	101.4P	328.8F
MSB	116108#	299.6H	101.4P	328.8F
R1D	63649#	394.3H	254.6P	402.6F
R1B	63649#	394.3H	254.6P	402.6F
R2D	172369#	535.0H	868.2P	527.7F
R2B	172916#	536.0H	874.3P	528.5F

GROSS GENERATOR OUTPUT
585.3 MW
0.90 POWER FACTOR
90.0 PSIA H₂ PRESSURE
5725 kW MECH. LOSSES
13559 kW ELEC. LOSSES

- Notes:
1. Flows are schematic only and may represent two or more parallel paths.
 2. FW heater vent flows are not modeled.
 3. 1st and 2nd stage reheater scavenging steam is not modeled.
 4. ETRF is estimated based on the thermal kit, and not benchmarked.
 5. Generator p.f. is used to compute var losses. It should not be used for electrical system evaluations.
 6. MSR reheat and heating steam P, T, & H shown for the 'B,' 'C' vessels as representative.

Gross Power:	585.3 MW	50% Extraction
NSSS Power:	3651.5 MWt	
Gross HR:	21286B/kWh	
P - Pressure, psia	MW - Megawatts	Prepared by: Gabriel Neimark
F - Temperature, F	MWs - Megawatts Shaft Power	
# - Flow Rate, lbm/hr	MWt - Megawatts Thermal	Reviewed by: Nic Richards
× - Quality		Date: 10/26/23

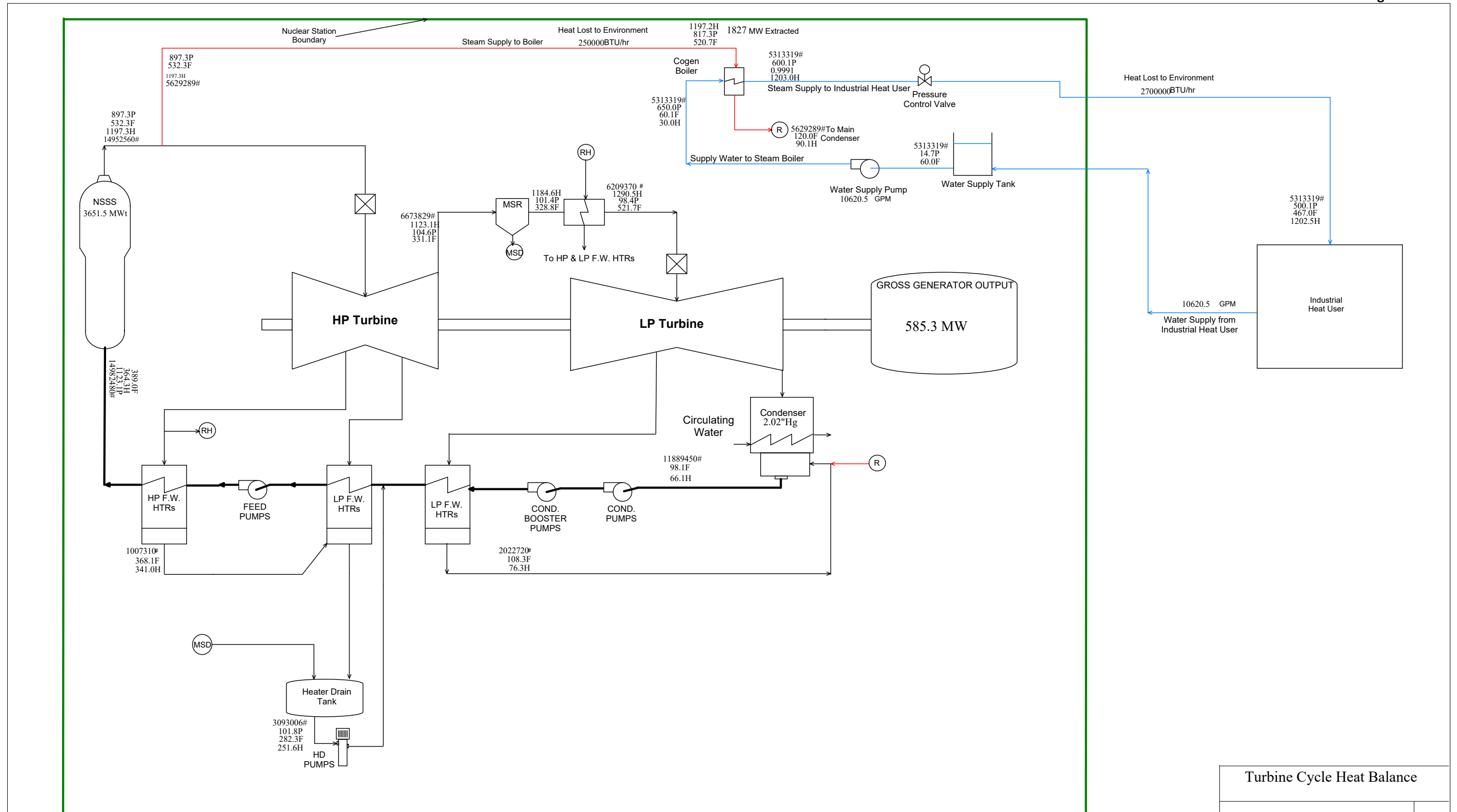

Turbine Cycle Heat Balance	

50% Extraction	
P - Pressure, psia	MW - Megawatts
F - Temperature, F	MWs - Megawatts Shaft Power
H - Enthalpy, Btu/lbm	MWt - Megawatts Thermal
# - Flow Rate, lbm/hr	
x - Quality	
Prepared by: Gabriel Neimark	Date: 10/26/23
Reviewed by: Nic Richards	Date: 10/26/23

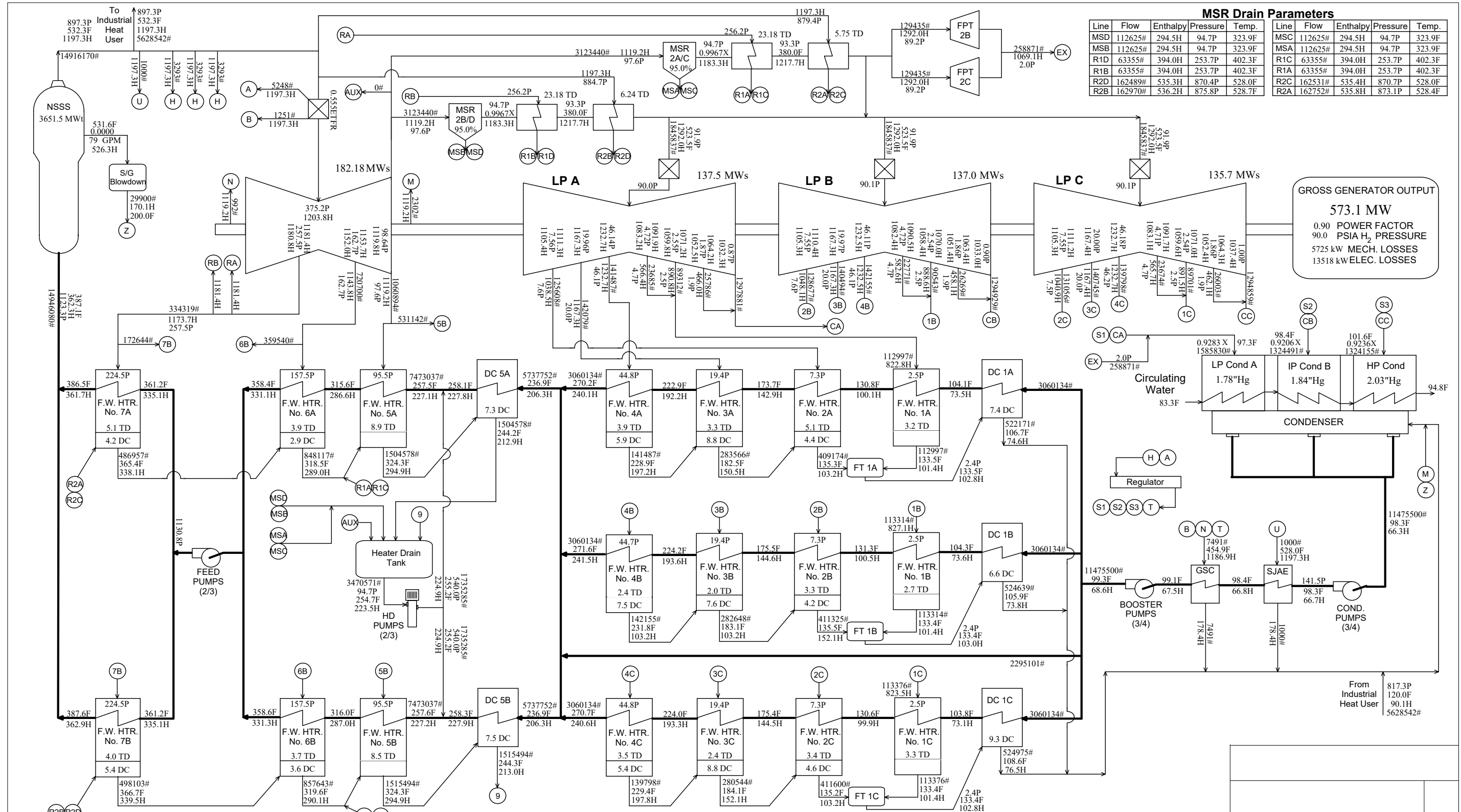

MSR Drain Parameters

Line	Flow	Enthalpy	Pressure	Temp.
MSD	112625#	294.5H	94.7P	323.9F
MSB	112625#	294.5H	94.7P	323.9F
R1D	63355#	394.0H	253.7P	402.3F
R1B	63355#	394.0H	253.7P	402.3F
R2D	16248#	535.3H	870.4P	528.0F
R2B	162970#	536.2H	875.8P	528.7F

Line	Flow	Enthalpy	Pressure	Temp.
MSC	112625#	294.5H	94.7P	323.9F
MSA	112625#	294.5H	94.7P	323.9F
R1C	63355#	394.0H	253.7P	402.3F
R1A	63355#	394.0H	253.7P	402.3F
R2C	162531#	535.4H	870.7P	528.0F
R2A	162752#	535.8H	873.1P	528.4F

GROSS GENERATOR OUTPUT
573.1 MW
 0.90 POWER FACTOR
 90.0 PSIA H₂ PRESSURE
 5725 kW MECH. LOSSES
 13518 kW ELEC. LOSSES

- Notes:
1. Flows are schematic only and may represent two or more parallel paths.
 2. FW heater vent flows are not modeled.
 3. 1st and 2nd stage reheater scavenging steam is not modeled.
 4. ETRF is estimated based on the thermal kit, and not benchmarked.
 5. Generator p.f. is used to compute var losses. It should not be used for electrical system evaluations.
 6. MSR reheat and heating steam P, T, & H shown for the 'B,' 'C' vessels as representative.

Gross Power:	573.1 MW	50% Extraction with 20% LP FWH Bypass
NSSS Power:	3651.5 MWt	
Gross HR:	21739B/kWh	
P - Pressure, psia	MW - Megawatts	Prepared by: Gabriel Neimark
F - Temperature, F	MWs - Megawatts Shaft Power	
# - Flow Rate, lbm/hr	MWt - Megawatts Thermal	Reviewed by: Nic Richards
× - Quality		Date: 10/26/23

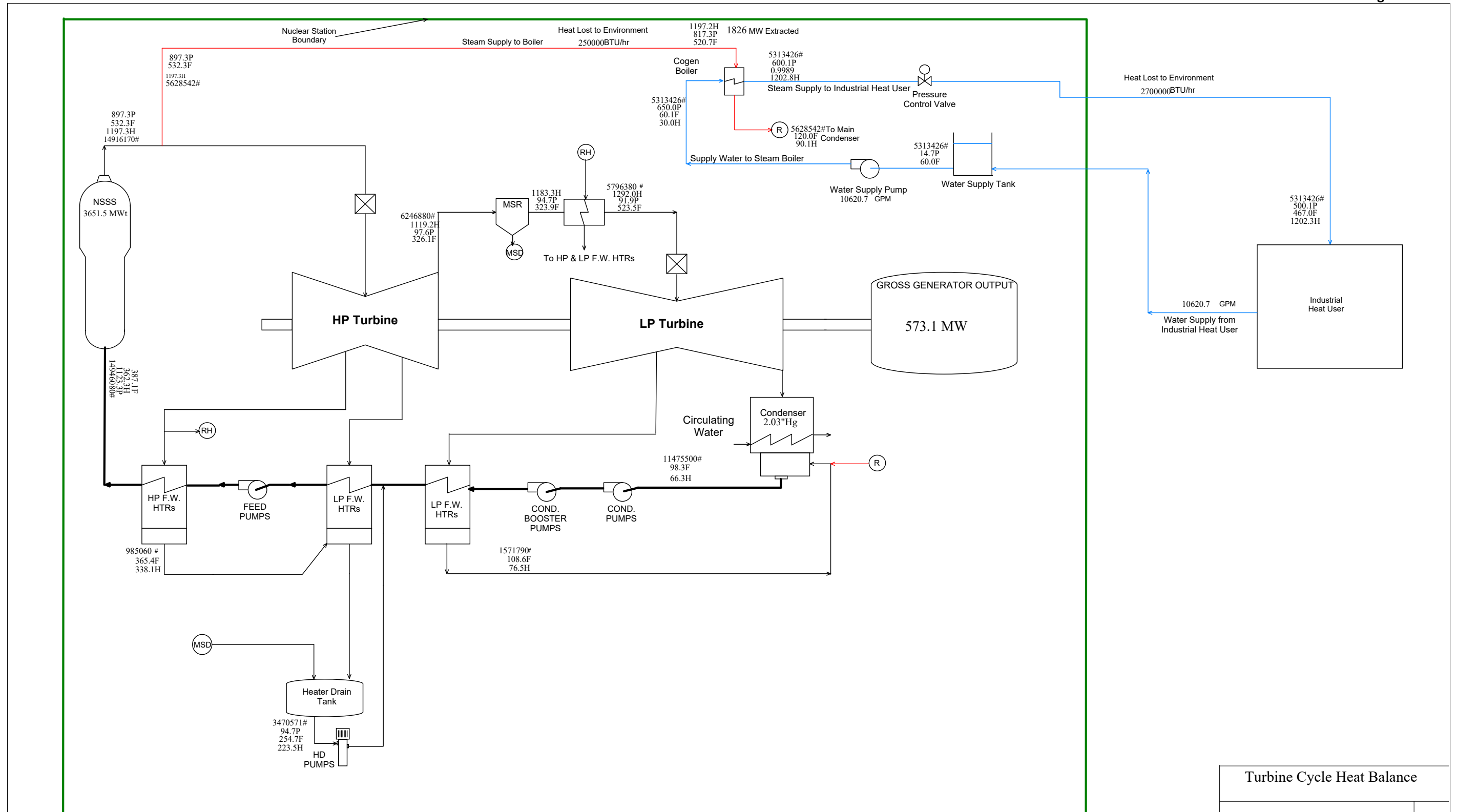

Turbine Cycle Heat Balance	

50% Extraction with 20% LP FWH Bypass

P - Pressure, psia MW - Megawatts
 F - Temperature, F MWs - Megawatts Shaft Power
 H - Enthalpy, Btu/lbm MWt - Megawatts Thermal
 # - Flow Rate, lbm/hr
 x - Quality

Prepared by: Gabriel Neimark	Date: 10/26/23
Reviewed by: Nic Richards	Date: 10/26/23

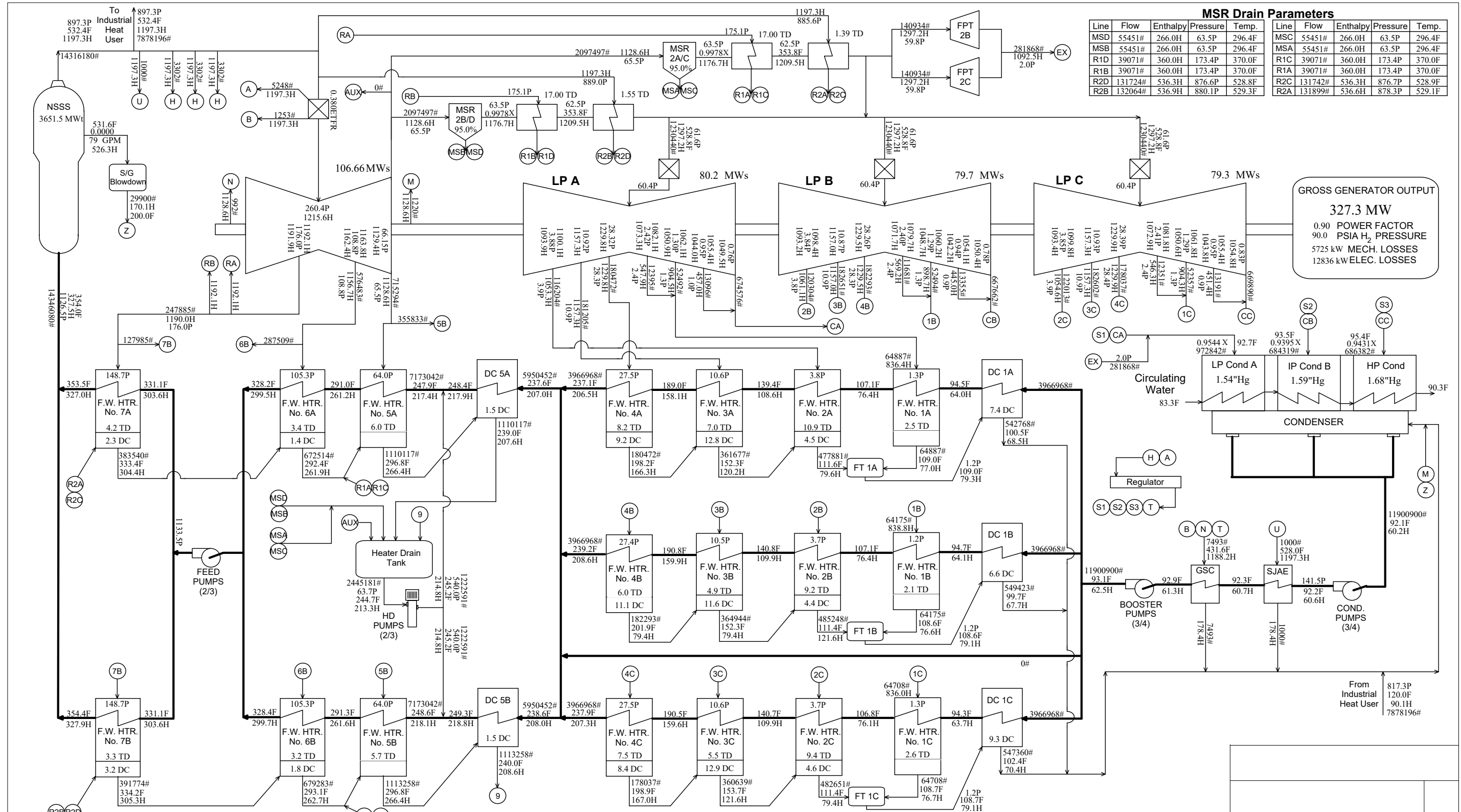

MSR Drain Parameters

Line	Flow	Enthalpy	Pressure	Temp.
MSD	55451#	266.0H	63.5P	296.4F
MSB	55451#	266.0H	63.5P	296.4F
R1D	39071#	360.0H	173.4P	370.0F
R1B	39071#	360.0H	173.4P	370.0F
R2D	131724#	536.3H	876.6P	528.8F
R2B	132064#	536.9H	880.1P	529.3F

GROSS GENERATOR OUTPUT
327.3 MW
 0.90 POWER FACTOR
 90.0 PSIA H₂ PRESSURE
 5725 kW MECH. LOSSES
 12836 kW ELEC. LOSSES

- Notes:
1. Flows are schematic only and may represent two or more parallel paths.
 2. FW heater vent flows are not modeled.
 3. 1st and 2nd stage reheater scavenging steam is not modeled.
 4. ETFR is estimated based on the thermal kit, and not benchmarked.
 5. Generator p.f. is used to compute var losses. It should not be used for electrical system evaluations.
 6. MSR reheat and heating steam P, T, & H shown for the 'B,' 'C' vessels as representative.

Gross Power:	327.3 MW	2556MwT (70%) Extraction
NSSS Power:	3651.5 MWt	
Gross HR:	38069B/kWh	
P - Pressure, psia	MW - Megawatts	Prepared by: Gabriel Neimark
F - Temperature, F	MWs - Megawatts Shaft Power	
# - Flow Rate, lbm/hr	MWt - Megawatts Thermal	Reviewed by: Nic Richards
× - Quality		Date: 11/15/23

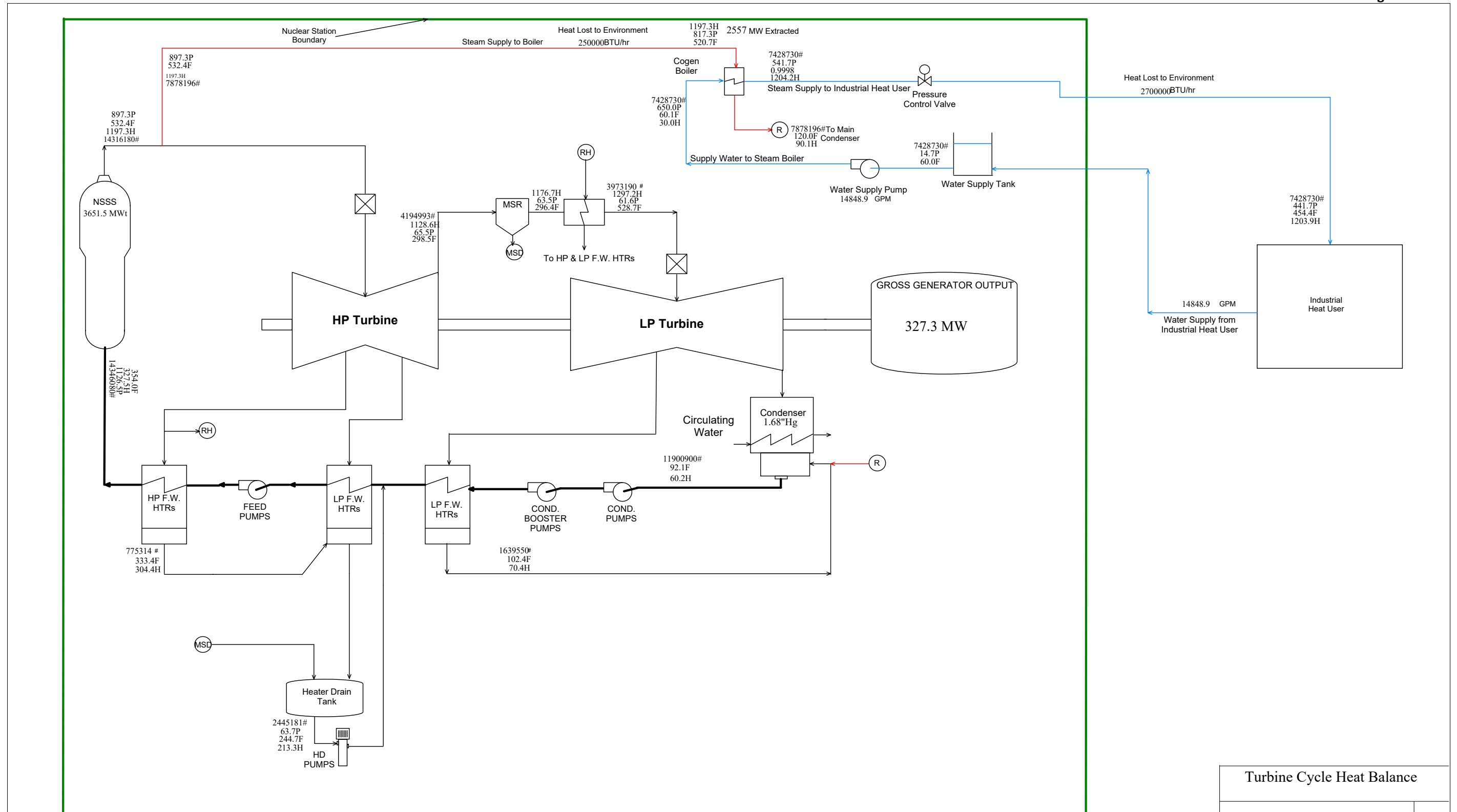

Turbine Cycle Heat Balance	

2556MWt (70%) Extraction

P - Pressure, psia
 F - Temperature, F
 H - Enthalpy, Btu/lbm
 # - Flow Rate, lbm/hr
 x - Quality

MW - Megawatts
 MWs - Megawatts Shaft Power
 MWt - Megawatts Thermal

Prepared by: Gabriel Neimark	Date: 11/15/23
Reviewed by: Nic Richards	Date: 11/15/23

Attachment B – HP and LP Turbine Assessment with 30% Thermal Energy Extracted

Prepared: Nic Richards

Reviewed: Pawel Kut

Attachment B
HP and LP Turbine Assessment – 30% Thermal Extraction

B1.0 PURPOSE

The purpose of this appendix is to assess the turbine performance and expected changes to operating conditions due to operation with 30% turbine cycle thermal energy extracted from the main steam.

B2.0 SYSTEM & COMPONENT DESCRIPTION

A representative turbine cycle is chosen to evaluate the impact of energy extraction. A PWR unit with a single High Pressure Turbine (HPT) and three parallel Low Pressure Turbines (LPTs) is used. The representative cycle contains a Moisture Separator Reheater (MSR) between the HPT and LPTs, where moisture is removed from the HPT exhaust and heated with two stages of regenerative heating. The turbines provide extraction to seven feedwater heater stages.

The representative turbine cycle performance is modeled in a PEPSE™ model which contains cases benchmarked to the turbine vendor's thermal kit. Cases at Valves Wide Open (VWO), rated thermal power (100%), and 75% power are provided.

For the case with 30% turbine cycle thermal energy extracted, the PEPSE heat balance was modified as documented in Attachment A. The modification included removal of steam from the main steam system and return of the condensate to the main condenser after the energy was extracted.

B3.0 METHODOLOGY**B3.1 Enthalpy-Entropy Chart**

Turbine performance modeled by PEPSE is visually represented on an Enthalpy-Entropy Chart. Turbine interstage pressures and enthalpies are taken from the PEPSE model for the Rated Load and 75% Load cases (see Input B5.1) to determine design turbine performance. The entropy of each condition is computed using Excel add-on STMFUNC, and plotted against the corresponding enthalpy. The same properties are extracted from the PEPSE model for the baseline scenario (0% thermal extraction) and 30% turbine cycle thermal energy extracted and plotted for comparison to the design turbine performance.

B3.2 Flow Comparison

The interstage mass flow rates from the baseline scenario and 30% turbine cycle thermal energy extracted case are compared. Any increases in flows are noted. Also, as the HPT is not symmetrical (FWH7 and 2nd Stage Reheat (RH2) extractions are taken from the right side and FWH6 extraction from the left), flow rates are reviewed for any potential imbalance between the two sides created when operating with 30% turbine cycle thermal energy extracted.

B4.0 ASSUMPTIONS

None

Attachment B
HP and LP Turbine Assessment – 30% Thermal Extraction

B5.0 DESIGN INPUTS**B5.1 Turbine Design Conditions at Rated and 75% Load**

Turbine flows, pressures, and enthalpies are taken from the PEPSE model for the rated and 75% Load design case and presented in Table B5-1 below.

Table B5-1 – Turbine Design Values (from PEPSE™)

Location	Rated Load			75% Load		
	Mass Flow [lbm/hr]	Pressure [psia]	Enthalpy [BTU/lbm]	Mass Flow [lbm/hr]	Pressure [psia]	Enthalpy [BTU/lbm]
Throttle Valve Inlet	15,606,360	882.0	1,195	10,980,900	948.9	1,193
HPT Bowl (Left)	7,803,179	834.6	1,195	5,490,452	583.8	1,193
Governing Stage Shell (Left)	7,803,179	666.4	1,179	5,490,452	473.0	1,188
FWH6 Extraction Stage (Left)	6,976,506	302.7	1,128	5,001,862	222.3	1,142
HPT Exhaust (Left)	6,976,506	192.1	1,099	5,001,862	144.9	1,113
HPT Bowl (Right)	7,803,179	834.6	1,195	5,490,452	583.8	1,193
Governing Stage Shell (Right)	7,803,179	666.4	1,178	5,490,452	473.3	1,186
FWH7 + RH2 Extraction Stage (Right)	6,517,590	447.4	1,154	4,791,225	329.6	1,166
HPT Exhaust (Right)	6,517,590	192.1	1,099	4,791,225	144.9	1,113
LPT A Bowl	3,675,072	175.3	1,273	2,743,459	132.2	1,282
FWH4A Extraction Stage	3,471,365	92.2	1,218	2,601,926	69.8	1,226
FWH3A Extraction Stage	3,277,938	41.9	1,158	2,467,812	31.4	1,165
FWH2A Extraction Stage	3,075,305	16.4	1,105	2,328,238	12.4	1,111
MR (to FWH1A) Extraction Stage	3,015,678	10.2	1,088	2,286,391	7.7	1,092
FWH1A Extraction Stage	2,869,644	5.62	1,068	2,206,928	4.31	1,072
MR (to LPT A Exhaust) Extraction Stage	2,801,781	3.44	1,057	2,158,431	2.64	1,060
LPT A Exhaust	2,801,781	1.72	1,026	2,158,431	1.72	1,038
LPT B Bowl	3,675,072	175.5	1,273	2,743,459	132.4	1,282
FWH4B Extraction Stage	3,471,369	92.2	1,218	2,601,930	69.8	1,226

Attachment B
HP and LP Turbine Assessment – 30% Thermal Extraction

Location	Rated Load			75% Load		
	Mass Flow [lbm/hr]	Pressure [psia]	Enthalpy [BTU/lbm]	Mass Flow [lbm/hr]	Pressure [psia]	Enthalpy [BTU/lbm]
FWH3B Extraction Stage	3,277,928	41.9	1,158	2,467,806	31.4	1,165
FWH2B Extraction Stage	3,075,253	16.4	1,105	2,328,200	12.4	1,111
MR (to FWH1B) Extraction Stage	3,015,598	10.2	1,088	2,286,331	7.7	1,092
FWH1B Extraction Stage	2,869,548	5.62	1,068	2,206,856	4.31	1,072
MR (to LPT B Exhaust) Extraction Stage	2,801,669	3.44	1,057	2,158,346	2.64	1,060
LPT B Exhaust	2,801,669	1.72	1,026	2,158,346	1.72	1,037
LPT C Bowl	3,675,072	175.5	1,273	2,743,459	132.4	1,282
FWH4C Extraction Stage	3,471,370	92.2	1,218	2,601,930	69.8	1,226
FWH3C Extraction Stage	3,277,928	41.9	1,158	2,467,806	31.4	1,165
FWH2C Extraction Stage	3,075,259	16.4	1,105	2,328,195	12.4	1,111
MR (to FWH1C) Extraction Stage	3,015,604	10.2	1,088	2,286,326	7.7	1,092
FWH1C Extraction Stage	2,869,642	5.62	1,068	2,206,766	4.31	1,072
MR (to LPT C Exhaust) Extraction Stage	2,801,762	3.44	1,057	2,158,258	2.64	1,060
LPT C Exhaust	2,801,762	1.72	1,026	2,158,258	1.72	1,037

B5.2 Turbine Baseline and 30% Thermal Extraction Conditions

Turbine flows, pressures, and enthalpies are taken from the PEPSE model for the baseline (0% thermal extraction) and 30% Thermal Extraction cases and presented in Table B5-2 below.

Table B5-2 – Turbine Performance Values (from PEPSE™)

Location	Baseline (0% Thermal Extraction)			30% Thermal Extraction		
	Mass Flow [lbm/hr]	Pressure [psia]	Enthalpy [BTU/lbm]	Mass Flow [lbm/hr]	Pressure [psia]	Enthalpy [BTU/lbm]
Throttle Valve Inlet	15,218,400	870.3	1,197	11,272,260	870.3	1,197
HPT Bowl (Left)	7,609,201	801.5	1,197	5,636,129	552.2	1,197
Governing Stage Shell (Left)	7,609,201	651.5	1,182	5,636,129	487.5	1,194

Attachment B
HP and LP Turbine Assessment – 30% Thermal Extraction

Location	Baseline (0% Thermal Extraction)			30% Thermal Extraction		
	Mass Flow [lbm/hr]	Pressure [psia]	Enthalpy [BTU/lbm]	Mass Flow [lbm/hr]	Pressure [psia]	Enthalpy [BTU/lbm]
FWH6 Extraction Stage (Left)	6,808,507	296.5	1,132	4,939,882	219.7	1,145
HPT Exhaust (Left)	6,808,507	192.2	1,104	4,939,882	141.7	1,115
HPT Bowl (Right)	7,609,201	801.5	1,197	5,636,129	552.2	1,197
Governing Stage Shell (Right)	7,609,201	651.6	1,182	5,636,129	487.8	1,193
FWH7 + RH2 Extraction Stage (Right)	6,550,264	451.0	1,159	4,879,028	337.0	1,171
HPT Exhaust (Right)	6,550,264	192.2	1,104	4,879,028	141.7	1,115
LPT A Bowl	3,673,069	175.5	1,274	2,677,248	129.3	1,283
FWH4A Extraction Stage	3,470,241	92.3	1,219	2,479,494	66.5	1,226
FWH3A Extraction Stage	3,271,723	41.8	1,159	2,285,586	29.0	1,162
FWH2A Extraction Stage	3,075,061	16.4	1,106	2,108,017	11.2	1,108
MR (to FWH1A) Extraction Stage	3,015,812	10.2	1,088	2,069,513	7.0	1,089
FWH1A Extraction Stage	2,855,450	5.60	1,068	1,931,433	3.75	1,068
MR (to LPT A Exhaust) Extraction Stage	2,788,284	3.43	1,057	1,889,616	2.42	1,059
LPT A Exhaust	2,788,284	1.24	1,022	1,889,616	1.00	1,023
LPT B Bowl	3,673,069	175.7	1,274	2,677,248	129.4	1,283
FWH4B Extraction Stage	3,468,763	92.3	1,219	2,478,139	66.5	1,225
FWH3B Extraction Stage	3,273,638	41.8	1,159	2,287,097	29.0	1,162
FWH2B Extraction Stage	3,068,421	16.4	1,106	2,102,369	11.1	1,107
MR (to FWH1B) Extraction Stage	3,008,809	10.2	1,088	2,064,802	7.0	1,088
FWH1B Extraction Stage	2,847,364	5.58	1,068	1,924,897	3.74	1,067
MR (to LPT B Exhaust) Extraction Stage	2,780,228	3.42	1,057	1,882,541	2.42	1,059
LPT B Exhaust	2,780,228	1.38	1,023	1,882,541	1.07	1,024

Attachment B
HP and LP Turbine Assessment – 30% Thermal Extraction

Location	Baseline (0% Thermal Extraction)			30% Thermal Extraction		
	Mass Flow [lbm/hr]	Pressure [psia]	Enthalpy [BTU/lbm]	Mass Flow [lbm/hr]	Pressure [psia]	Enthalpy [BTU/lbm]
LPT C Bowl	3,673,069	175.7	1,274	2,677,249	129.4	1,283
FWH4C Extraction Stage	3,473,448	92.4	1,219	2,482,813	66.6	1,226
FWH3C Extraction Stage	3,278,225	41.9	1,159	2,291,586	29.1	1,162
FWH2C Extraction Stage	3,070,612	16.4	1,106	2,103,231	11.1	1,107
MR (to FWH1C) Extraction Stage	3,011,389	10.2	1,088	2,064,763	7.0	1,089
FWH1C Extraction Stage	2,850,762	5.59	1,068	1,926,528	3.74	1,068
MR (to LPT C Exhaust) Extraction Stage	2,783,458	3.42	1,057	1,884,387	2.42	1,059
LPT C Exhaust	2,783,458	1.64	1,028	1,884,387	1.22	1,029

B6.0 REFERENCES

- B6.1 Computer Code PEPSE™ (Performance Evaluation of Power System Efficiencies), Version 84.1 by Scientech Incorporated, S&L Program No. 03.7.551-84.0, Controlled File Path: C:\Program Files (x86)\Applis\PEP55184\
- B6.2 STMFUNC, "Steam Table Function Dynamic Link Library," S&L Program Number 03.7.598-2.0

Attachment B
 HP and LP Turbine Assessment – 30% Thermal Extraction

B7.0 EVALUATIONS

B7.1 H-S Diagram

Turbine performance can be visualized by plotting on an enthalpy-entropy chart (H-S). Figures B7-1 and B7-2 plot the design turbine performance at 100% and 75% thermal power along with the baseline and 30% extraction cases.

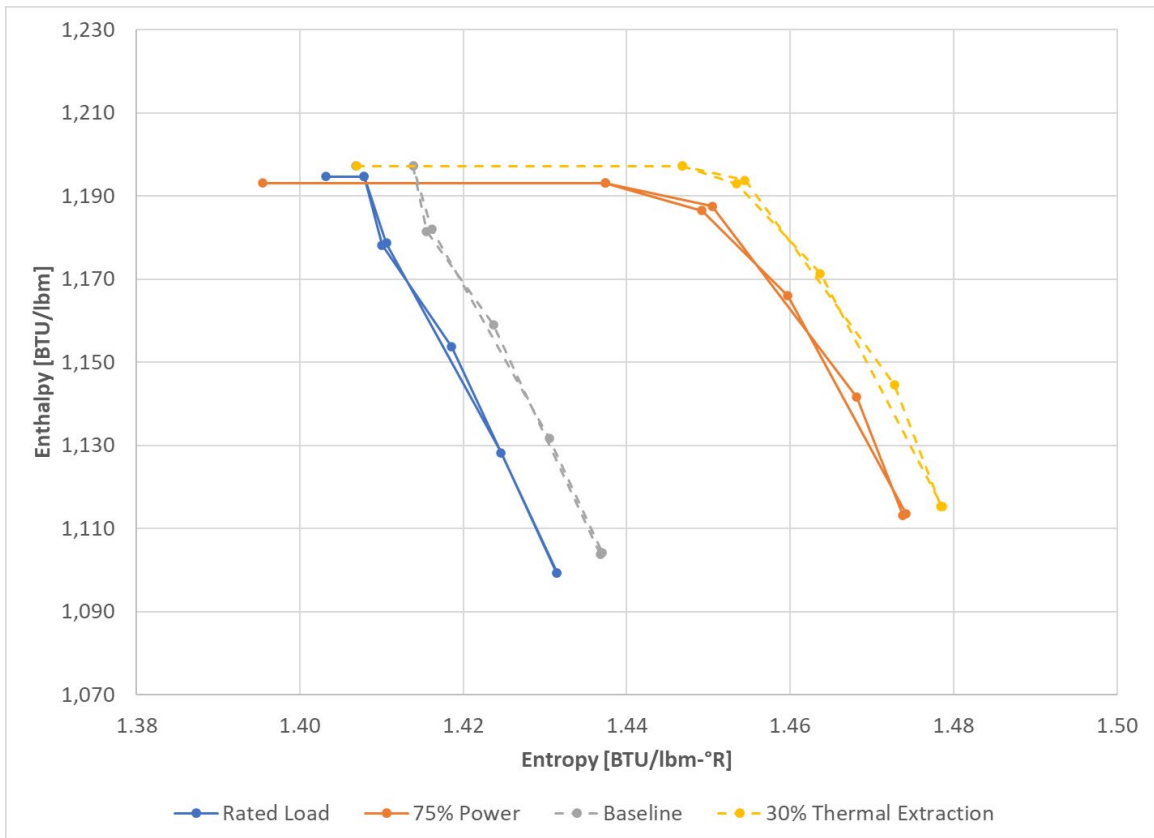

Figure B7-1: Enthalpy-Entropy Chart (HPT)

Attachment B
 HP and LP Turbine Assessment – 30% Thermal Extraction

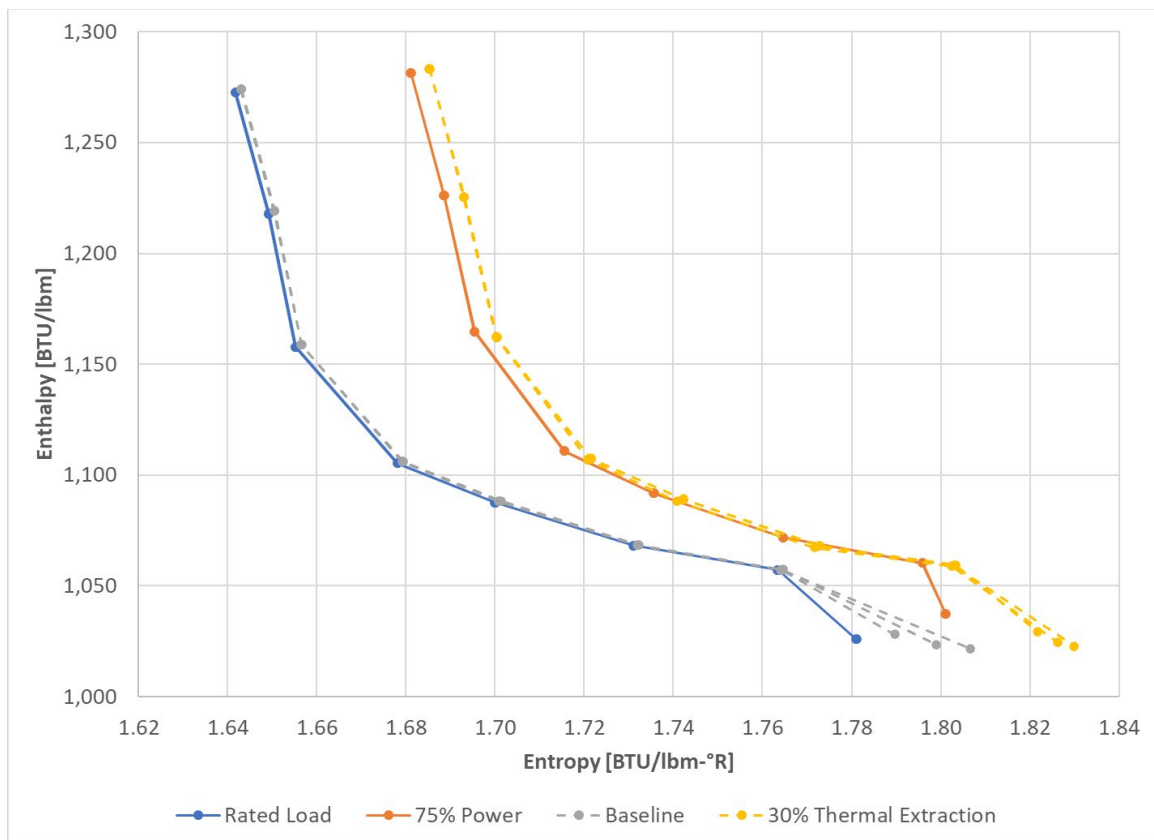

Figure B7-2: Enthalpy-Entropy Chart (LPT)

As shown in Figures B7-1 and B7-2, the Baseline turbine performance trends very closely to the Rated Load case. Similarly, the 30% Extraction turbine performance trends closely to the 75% Power case.

B7.2 Flow Comparison

Table B7-1 provides a comparison of the mass flow rates from baseline scenario to 30% power extraction.

Table B7-1 – Mass Flow Comparison

Location	Baseline (0% Thermal Extraction) [lbm/hr]	30% Thermal Extraction [lbm/hr]	Percent Change [-]
Throttle Valve Inlet	15,218,400	11,272,260	-26%
HPT Bowl (Left)	7,609,201	5,636,129	-26%
Governing Stage Shell (Left)	7,609,201	5,636,129	-26%
FWH6 Extraction Stage (Left)	6,808,507	4,939,882	-27%
HPT Exhaust (Left)	6,808,507	4,939,882	-27%
HPT Bowl (Right)	7,609,201	5,636,129	-26%
Governing Stage Shell (Right)	7,609,201	5,636,129	-26%
FWH7 + RH2 Extraction Stage (Right)	6,550,264	4,879,028	-26%

Attachment B
HP and LP Turbine Assessment – 30% Thermal Extraction

Location	Baseline (0% Thermal Extraction) [lbm/hr]	30% Thermal Extraction [lbm/hr]	Percent Change [-]
HPT Exhaust (Right)	6,550,264	4,879,028	-26%
LPT A Bowl	3,673,069	2,677,248	-27%
FWH4A Extraction Stage	3,470,241	2,479,494	-29%
FWH3A Extraction Stage	3,271,723	2,285,586	-30%
FWH2A Extraction Stage	3,075,061	2,108,017	-31%
MR (to FWH1A) Extraction Stage	3,015,812	2,069,513	-31%
FWH1A Extraction Stage	2,855,450	1,931,433	-32%
MR (to LPT A Exhaust) Extraction Stage	2,788,284	1,889,616	-32%
LPT A Exhaust	2,788,284	1,889,616	-32%
LPT B Bowl	3,673,069	2,677,248	-27%
FWH4B Extraction Stage	3,468,763	2,478,139	-29%
FWH3B Extraction Stage	3,273,638	2,287,097	-30%
FWH2B Extraction Stage	3,068,421	2,102,369	-31%
MR (to FWH1B) Extraction Stage	3,008,809	2,064,802	-31%
FWH1B Extraction Stage	2,847,364	1,924,897	-32%
MR (to LPT B Exhaust) Extraction Stage	2,780,228	1,882,541	-32%
LPT B Exhaust	2,780,228	1,882,541	-32%
LPT C Bowl	3,673,069	2,677,249	-27%
FWH4C Extraction Stage	3,473,448	2,482,813	-29%
FWH3C Extraction Stage	3,278,225	2,291,586	-30%
FWH2C Extraction Stage	3,070,612	2,103,231	-32%
MR (to FWH1C) Extraction Stage	3,011,389	2,064,763	-31%
FWH1C Extraction Stage	2,850,762	1,926,528	-32%
MR (to LPT C Exhaust) Extraction Stage	2,783,458	1,884,387	-32%
LPT C Exhaust	2,783,458	1,884,387	-32%

As shown in Table B7-1, the turbine experiences a ~26% to ~32% reduction in mass flow rate when operating with 30% thermal energy extracted for off-site use. Notably, the HPT interstage flows all decrease by a similar margin (~27%). This is important as the HPT is not symmetric, with FWH7 and 2nd Stage Reheat (RH2) extractions coming off the right side and FWH6 extraction coming from the left. Based on the consistent reduction in flow on either side, additional stress due to imbalanced loading on the turbine is not expected.

Attachment B
HP and LP Turbine Assessment – 30% Thermal Extraction

B8.0 RESULTS AND CONCLUSIONS

A review of the turbine performance modeled in PEPSE for baseline (0% thermal extraction) and 30% thermal energy extraction conditions shows good alignment with the design turbine performance at rated and 75% thermal power conditions. The turbine is expected to experience a reduction in mass flow rate of at least 25% when operating with 30% thermal energy extracted for off-site use. HPT flows are expected to reduce by a similar amount on either side of the HPT flow path. Therefore, additional stress due to imbalanced loading on the turbine is not expected.

Based on the review of the PEPSE heat balance conditions, the turbine is expected to operate within design for operation with up to 30% thermal energy extracted for off-site use. However, final acceptability of operation under this condition must be confirmed with the turbine vendor on a plant specific basis.

The turbine control system is expected to require changes to accommodate operation with thermal energy extracted for off-site use. The evaluation of, and potential changes to, turbine controls needs to be performed separately and is not within the scope of this assessment.

Attachment C – Condenser Evaluation with 30% Thermal Energy Extracted

Prepared: Gabriel Neimark

Reviewed: Nic Richards

C1.0 PURPOSE

The purpose of this evaluation is to examine required duty and expected changes to operating conditions and performance parameters in relation to the design of the Main Condenser. These changes are due to steam extraction for supplying thermal energy off-site. These evaluations are done for the scenario where 30% thermal energy is extracted from main steam.

C2.0 SYSTEM & COMPONENT DESCRIPTION

The main condenser is the steam cycle heat sink. During normal operation it receives and condenses main turbine exhaust steam. Turbine bypass steam is also routed to the main condenser when required. The main condenser is also a collection point for other steam cycle miscellaneous flows, drains, and vents

Although there are three independent zones for steam flow, the condenser has a single pass of Circulating Water (CW). CW enters at the low pressure zone, passes through the intermediate pressure zone and exits at the high pressure zone. The cold surface of the stainless steel tubes condenses the steam into water, which is collected in the hotwell.

The purpose of the main condenser evacuation and off-gas system is to maintain a vacuum in the condenser and to remove noncondensable gas (including air inleakage and other noncondensable gases introduced to the condenser).

For the purpose of this assessment it is assumed that the main steam used for the 30% thermal extraction is condensed and routed back to the main condenser as shown on PEPSE Heat Balance diagrams documented in Attachment A.

C3.0 METHODOLOGY

The operating conditions of the main condenser are evaluated for the 30% thermal extraction scenario and compared to baseline operation. These operating conditions are taken from the PEPSE Heat Balance results documented in Attachment A. The results of this comparison are used to evaluate the impact on condenser thermal performance and flow-induced tube vibration.

The required air removal capacity is not specifically evaluated as, during power operation, the major sources of noncondensable gases in the main condenser are air leaks in the condenser shell, which is not expected to change for the 30% thermal extraction scenario.

C4.0 ASSUMPTIONS

- C4.1 Circulating Water Conditions – The PEPSE results presented in Attachment A assume constant Circulating Water (CW) conditions (inlet temperature and flow rate) between the baseline and 30% thermal energy extraction cases. This is assumed for simplicity and is reasonable as thermal energy extraction is not expected to have any impact on CW availability.

C5.0 DESIGN INPUTS

Operating conditions are taken from the PEPSE Heat Balance results documented in Attachment A and presented in Table C7-1.

C6.0 REFERENCES

None

C7.0 EVALUATIONS

The condenser operating conditions for the baseline and 30% thermal extraction scenarios are compared in Table C7-1.

Table C7-1: Condenser Operating Conditions

Description	Units	0%	30%	Δ (30%)
Condenser A Shell Pressure	psia	1.24	1.01	-18.9%
Condenser A Shell Flow	lbm/hr	3,120,435	2,198,666	-29.5%
Condenser A Duty	BTU/hr	2.92E+09	2.11E+09	-27.8%
Condenser B Shell Pressure	psia	1.38	1.07	-22.5%
Condenser B Shell Flow	lbm/hr	2850639	1,928,182	-32.4%
Condenser B Duty	BTU/hr	2.64E+09	1.83E+09	-30.7%
Condenser C Shell Pressure	psia	1.64	1.22	-25.9%
Condenser C Shell Flow	lbm/hr	2,854,037	1,929,813	-32.4%
Condenser C Duty	BTU/hr	2.65E+09	1.85E+09	-30.4%
Hotwell Temperature	°F	115.6	105.1	-10.5°F
Condensate Flow	lbm/hr	11,334,490	11,723,820	3.43%

As shown in Table C7-1, with constant CW conditions, condenser backpressures decrease when thermal energy is extracted, so this scenario will not trigger a high backpressure alarm or exceed the turbine trip setpoint. Any limits on condensate hotwell temperature will not be challenged as this temperature decreases for the thermal extraction case. Decreased steam flow rates will also reduce the severity of flow-induced vibrations. Since the main steam used for the 30% thermal extraction is condensed and routed back to the main condenser there is a small increase in the total condensate flow. Additionally, since the overall condenser duty goes down with thermal energy extraction, the condenser's ability to accept turbine bypass steam is not affected.

C8.0 RESULTS AND CONCLUSIONS

An evaluation of condenser operating conditions shows that the condenser will continue to meet operation requirements for 30% thermal extraction conditions. Condenser steam flow rates, backpressures, and heat loads decrease for the thermal extraction case, so backpressure limits will not be challenged, and the severity of flow-induced vibrations will be reduced. Due to the additional condensate routed back to the main condenser there is a small increase in the total condensate flow. Additionally, since the overall condenser duty goes down with thermal energy extraction, the condenser's ability to accept turbine bypass steam is not affected.

The evacuation capacity of the condensers is not affected by operating with 30% thermal extraction conditions.

Attachment D – Power Train Pumps Evaluation with 30% Thermal Energy Extracted

Prepared: Gabriel Neimark

Reviewed: Nic Richards

D1.0 PURPOSE

The purpose of this evaluation is to examine the required duty and expected changes to operating conditions and performance parameters in relation to the power train pumps and drivers, consisting of the Condensate Pumps (CDPs), Condensate Booster Pumps (CBPs), Heater Drain Pumps (HDPs), and the Feedwater Pumps (FWPs). Changes to the heater drain tank level control valves are also evaluated. These changes are due to extracting steam from the nuclear power cycle main steam system to supply thermal energy to the plant boundary for off-site use. These evaluations are done for the scenario where 30% thermal energy is extracted.

D2.0 SYSTEM & COMPONENT DESCRIPTION

D2.1 System Description

The power conversion system is a closed cycle, with the CD, CB, and FW systems working to deliver water from the condenser hotwell to the four Steam Generators (S/Gs). The CDPs draw water from the condenser and pump it through the Steam Jet Air Ejector (SJAЕ) condensers and gland steam condensers (GSCs) to the CBPs. The booster pumps provide the required head to pump the condensate through the Low Pressure (LP) FW heaters and to provide sufficient suction head at the two Turbine Driven Feed Pumps (TDFPs). The water collected from the heater drains is stored in the Heater Drain Tank (HDT) and is forwarded into the CB system upstream of the 5th point heaters through the HDPs. In the FW system, the water is pumped through one stage of High Pressure (HP) FW heaters and then on to four S/Gs.

D2.2 Pump Description

The suction energy level of each pump is given in table D2-1. This is used in determining the Preferred Operating Region and minimum NPSH ratio acceptance criteria for the pumps in Section D3.3.

Table D2-1: CDP Best Efficiency Point

	Suction Energy Evaluation (Low / High / Very High)
CDP	High
CBP	Very High
FWP	Very High

D3.0 METHODOLOGY & ACCEPTANCE CRITERIA

D3.1 Methodology

The power train pump systems evaluated in this report are the CDPs, CBPs, FWPs, and the HDPs, along with the associated HD tank control valves. Each system is analyzed through the use of a generic Fathom hydraulic model of the CD, CB, HD forwarding, and FW systems.

The condenser pressure, FW flow, HD flow, and water temperatures are taken from the PEPSE Heat Balance results documented in Attachment A. Cases are run for 1) no thermal extraction, and 2) 30% thermal extraction.

D3.2 Computer Programs and Software

The hydraulic model used in this task report is created using Fathom Version 11.0 [Ref. D6.1]. Fathom is run on S&L PC 13857 under the Windows 10 operating system.

D3.3 Acceptance Criteria

D3.3.1 Condensate Pumps

- a) Acceptance Criterion 3.3.1a: CDP Preferred Operating Region – Under normal operation, the CDPs should operate within the POR. Per HI Standards [Ref. D6.2], the POR for horizontal centrifugal pumps is between 70% and 120% of the BEP.
- b) Acceptance Criterion 3.3.1b: CDP Driver Horsepower – The CDPs and CBPs are driven by a common motor, yet the CDPs operate at a lower speed and are driven by gearbox connected to the motor. The CDP brake horsepower (BHP) should not exceed the rated service horsepower of the gearbox.
- c) Acceptance Criterion 3.3.1c: CDP NPSH Margin – Per Table 9.6.1.1 of the HI Standard 9.6.1 [Ref. D6.3], the guideline for the minimum NPSH margin ratio for high suction energy horizontal pumps in nuclear power applications is 2.0.

D3.3.2 Condensate Booster Pumps

- a) Acceptance Criterion 3.3.2a: CBP Preferred Operating Region – Under normal operation, the CBPs should operate within the POR. Per HI Standards [Ref. D6.2], the POR for horizontal centrifugal pumps is between 70% and 120% of the BEP.

-
- b) Acceptance Criterion 3.3.2b: CBP Driver Horsepower – The CBP is directly driven by the motor common to the CDPs and CBPs. The combined CDP and CBP BHP should not exceed the rated horsepower of this motor.
 - c) Acceptance Criterion 3.3.2c: CBP NPSH Margin – Per Table 9.6.1.1 of the HI Standard 9.6.1 [Ref. D6.3], the guideline for the minimum NPSH margin ratio for very high suction energy horizontal pumps in nuclear power applications is 2.5.

D3.3.3 Heater Drain Tank Pumps (HDPs)

- a) Acceptance Criteria 3.3.3a: Preferred Operating Region – The HI Standard for the allowable operating region [Ref. D6.2] states that for a vertical pump the most conservative POR is between 80% and 115% of the BEP.
- b) Acceptance Criterion 3.3.3b: HDP Driver Horsepower – The HDP BHP should not exceed the rated horsepower of its motor.
- c) Acceptance Criterion 3.3.3c: HDP NPSH Margin – HI Standard 9.6.1 [Ref. D6.2] states that vertical turbine pumps are designed to withstand constant cavitation. Therefore, the minimum NPSH ratio for the HDPs should be 1.0, yet this evaluation will conservatively evaluate the pumps to a minimum NPSH ratio requirement of 2.0.

D3.3.4 Turbine Driven Feed Pumps

- a) Acceptance Criterion 3.3.4a: TDFP Preferred Operating Region – The HI Standard for the allowable operating region [Ref. D6.2] states that the POR for a horizontal, centrifugal pump, is between 70% and 120% of the BEP.
- b) Acceptance Criterion 3.3.4b: TDFP Driver Horsepower – The TDFP BHP should not exceed the rated horsepower of the turbine.
- c) Acceptance Criterion 3.3.4c: TDFP NPSH Margin – Per Table 9.6.1.1 of the HI Standard 9.6.1 [Ref. D6.3], the guideline for the minimum NPSH margin ratio for very high suction energy horizontal pumps in nuclear power applications is 2.5.
- d) Acceptance Criterion 3.3.4d: Turbine Driven Feed Pump Speed – The turbine should have sufficient margin below the overspeed setpoint for the TDFPs.

D3.3.5 Control Valves

- a) Acceptance Criterion 3.3.5a: HD Tank Level Control Valve Position – The HD tank control valves operate together during normal conditions to control the HD pump flow, however it is required that one valve shall pass 100% of the HD flow with margin for control (< 80% open) in the event that one of the valves is failed closed. However, during normal operation with two valves, the valve position should not exceed 50% open.

D4.0 ASSUMPTIONS

- D4.1 Fugitive Flow – An additional 1% of total FW flow is added to the analysis cases to account for flows which are present in the system, but do not reach the S/Gs. Fugitive flow represents any unaccounted flows (i.e., valve leakage) and adds conservatism to the calculation. The fugitive flow is removed from the FW system at the feed pump discharge.

D5.0 DESIGN INPUTS

- D5.1 Operating Temperatures and Flows – The FW flow, HD Pump flow, condenser backpressure, and fluid temperatures are taken from the PEPSE Heat Balance results given in Attachment A. The parameters used as input to the hydraulic model are listed below in Table D5-1.

Table D5-1: PEPSE Input

Description	Units	0%	30%	Δ (30%)
DC 1A Discharge Temp	°F	126.3	113.3	-13.0°F
FWH 1A Discharge Temp	°F	161.1	144.2	-16.9°F
FWH 2A Discharge Temp	°F	210.1	189.9	-20.2°F
FWH 3A Discharge Temp	°F	263.1	241.3	-21.8°F
FWH 4A Discharge Temp	°F	314.3	291.3	-23.0°F
DC 5A Discharge Temp	°F	331.4	306.0	-25.5°F
FWH 5A Discharge Temp	°F	369.9	345.6	-24.3°F
FWH 5A Extraction Pressure	psia	186.1	137.1	-26.3%
FWH 6A Discharge Temp	°F	409.5	383.5	-25.9°F
FWH 7A Discharge Temp	°F	440.2	412.7	-27.5°F
DC 1B Discharge Temp	°F	126.6	113.5	-13.1°F
FWH 1B Discharge Temp	°F	161.7	144.8	-16.9°F
FWH 2B Discharge Temp	°F	212.8	192.6	-20.2°F
FWH 3B Discharge Temp	°F	265.0	243.3	-21.7°F

Attachment D

Power Train Pumps Evaluation – 30% Thermal Extraction

Description	Units	0%	30%	Δ (30%)
FWH 4B Discharge Temp	°F	316.4	293.5	-22.9°F
DC 5B Discharge Temp	°F	332.2	306.8	-25.4°F
FWH 5B Discharge Temp	°F	370.2	345.9	-24.3°F
FWH 5B Extraction Pressure	psia	186.1	137.1	-26.3%
FWH 6B Discharge Temp	°F	409.7	383.7	-25.9°F
FWH 7B Discharge Temp	°F	441.5	413.8	-27.7°F
DC 1C Discharge Temp	°F	125.9	113.0	-13.0°F
FWH 1C Discharge Temp	°F	160.8	143.9	-16.9°F
FWH 2C Discharge Temp	°F	212.7	192.5	-20.3°F
FWH 3C Discharge Temp	°F	264.6	242.9	-21.7°F
FWH 4C Discharge Temp	°F	315.0	292.0	-22.9°F
Average Condenser Pressures	in HG	2.89	2.24	-22.7%
Condensate Temperature	°F	115.6	105.1	-10.5°F
SJAE Outlet Temp	°F	115.8	105.3	-10.5°F
GSC Outlet Temp	°F	116.4	105.9	-10.5°F
FW Flow ¹	lbm/hr	16,067,280	15,466,190	-3.7%
HDT Temp	°F	336.6	307.7	-28.8°F
HD Flow	lbm/hr	4,732,792	3,742,365	-20.9%
HDT Pressure	psia	185.13	136.46	-26.3%

1) PEPSE flows do not include the 1% fugitive flow (see Assumption 4.1). Actual flows input to each feed pump are documented in Table D5-2.

D5.2 Feed Pump Flow - Based on the fugitive flow assumption (Assumption 4.1), Table D5-2 reports the actual flow values input to the FWPs for each case.

Table D5-2: Feed Pump Flows

	0%	30%
Final FW Flow (lbm/hr)	16,067,280	15,466,190
Fugitive Flow (lbm/hr)	160,673	154,662
Total Pump Flow (lbm/hr)	16,227,953	15,620,852
Flow per Pump (lbm/hr)	8,113,976	7,810,426

D6.0 REFERENCES

- D6.1 AFT Fathom™, Version 11.0, “Computer Software for Modeling Incompressible Flow in Pipe Networks,” S&L Program No. 03.7.721-11.0
- D6.2 ANSI/HI 9.6.3-1997, ‘American Nation Standard for Centrifugal/Vertical Pumps – Allowable Operating Region,’ *Hydraulic Institute*, Parsippany, NJ.
- D6.3 ANSI/HI 9.6.1-1998, “American National Standard for Centrifugal and Vertical Pumps for NPSH Margin,” *Hydraulic Institute*, Parsippany, NJ.

D7.0 EVALUATIONS

This section compares the model results for the 0% and 30% thermal extraction cases.

D7.1 Evaluation of the Preferred Operating Region

Centrifugal pumps are optimized for performance and service life at the BEP. At the BEP, hydraulic efficiency is maximized with flow entering the impeller vanes in a shockless manner. Within the POR of the pump, the flow is well controlled, and the pump will not be significantly affected by hydraulic loads, vibration, or flow separation [Ref. D6.2].

Table D7-1: Evaluation of Preferred Operating Region

Pump	Acceptance Criteria	0%	30%	Δ (30%)
CDP	70% - 120%	109.6	113.0	3.1%
CBP	70% - 120%	114.3	117.8	3.1%
TDFP	70% - 120%	99.1	95.2	-3.9%
HDP	80% - 115%	102.8	79.9	-22.3%

For the CDPs, CBPs, and TDFPs, the percent BEP remains within the associated POR, and changes from the base scenario to the 30% extraction case are minimal. The HDPs experience a significant change in operating point and will have to be evaluated on a plant-specific basis. However, it is not expected that any equipment changes will be required.

D7.2 Evaluation of Pump Driver Duty

The power requirement for each pump to perform as hydraulically characterized in the Fathom model is reported as part of the pump performance results. The calculated BHP of the pump must not exceed the rated horsepower of the associated driver, which is a motor and gearbox for the CDPs, a motor for the CBPs, a separate motor for the HDPs, and turbines for FWPs “B” and “C”. The duty on the CDP/CBP motor is taken as the sum of the CDP and CBP required BHP, as the motor must supply enough power to drive both pumps.

Table D7-2: Evaluation of Pump Driver Duty (hp)

Pump	0%	30%	Δ (30%)
CDP Gearbox	664	680	2.3%
CDP/CBP Motor	3157	3224	2.1%
TDFP Turbine	8590	8170	-4.9%
HDP Motor	1894	1877	-0.9%

The duty on the CDP gearbox and CDP/CBP motor increases slightly for the 30% extraction case. These will need to be evaluated against the rated horsepower of their associated drivers. The duty on the TDFP turbine and HDP motor decreases and should continue to meet the acceptance criteria for the 30% extraction case.

D7.3 Evaluation of Net Positive Suction Head Ratio

The NPSH ratio (NPSHa/NPSHr) is a measure of the available suction head margin for a pump. The NPSHa is the net positive suction head available to a pump. The NPSHr of a pump is defined as the NPSH that will cause the total head of the pump to be reduced by 3%, due to flow blockage from cavitation vapor in the impeller vanes [Ref. D6.3]. In order to limit noise, vibration, and overall reliability, minimum NPSH ratios for each pump are established as acceptance criteria, per the guideline values in Table 9.6.1.1 of the *Hydraulic Institute Standard on Centrifugal and Vertical Pumps for NPSH Margin* [Ref. D6.3]. The required NPSH ratio for the horizontal pumps (CDP, CBP, and FWP) is determined based on the pump suction energy level. Pumps with high suction energy require higher NPSH margins than those with low suction energy. As shown in the pump descriptions (see Section D2.2), the CDPs have high suction energy, while the CBPs and FWPs have very high suction energy. Vertical pumps often operate without NPSH margin, and only require that the NPSHa exceed the NPSHr. Though vertical pumps require an NPSH ratio of 1, a general acceptance criteria for of 2.0 is used for conservatism.

Table D7-3: Evaluation of NPSH Ratio

Pump	HI / ANSI Guideline	0%	30%	Δ (30%)
CDP	≥ 2.0	1.86	1.76	-5.5%
CBP	≥ 2.5	2.86	2.39	-16.5%
TDFP	≥ 2.5	2.42	3.55	46.7%
HDP	≥ 2.0	16.27	16.13	-0.9%

The NPSH ratio for the TDFPs significantly improves, and while the NPSH ratio decreases for the HDPs, this change is small. The CDP NPSH ratio is below the HI/ANSI guideline for both cases, but it is not expected that thermal extraction will significantly increase the risk of cavitation since the change from the baseline scenario is relatively small (~5.5%). The NPSH ratio for CBPs decreases more significantly (over 16%) and it falls below the guideline for the 30% extraction case. Therefore, although no physical changes are expected to the CDPs, CBPs, and HDPs, they should be evaluated for acceptance on a plant-specific basis for the 30% extraction case.

D7.4 Evaluation of Pump Suction and Discharge Pressure

Suction and discharge pressures for each pump are compared in Tables D7-4 and D7-5. This evaluation is used to see which pumps may be at risk of falling below alarm setpoints.

Table D7-4: Pump Suction Pressures (psig)

Pump	0%	30%	Δ (30%)
CDP	-5.1	-5.5	-3.9%
CBP	99.2	94.9	-3.8%
TDFP	425.0	412.3	-2.9%
HDP	184.8	136.5	-24.2%

Table D7-5: Pump Discharge Pressures (psig)

Pump	0%	30%	Δ (30%)
CDP	129.5	127.1	-1.6%
CBP	584.3	570.3	-2.3%
TDFP	1130.5	1122.1	-0.7%
HDP	696.1	763.6	9.5%

Overall, suction and discharge pressures decrease for the 30% thermal extraction case. Suction pressures will need to be evaluated on a plant-specific basis to ensure that they do not fall below low alarm setpoints.

D7.5 Evaluation of Turbine Driven Feedwater Pump Speed

The FW flow through the pumps is regulated by the speed of the driving turbine, which receives steam from the main steam system. In the Fathom model, the turbine speed is calculated based on the required flow and developed head required of the TDFPs.

Table D7-6: Evaluation of FWP Turbine Speed (rpm)

	0%	30%	Δ (30%)
Max Calculated Turbine Speed	5,022	4,934	-1.8%

The max calculated turbine speed decreases, so the margin improves for the 30% extraction case and should not challenge the acceptance criteria for TDFP speed.

D7.6 Evaluation of Heater Drain Tank Level Control Valves

The heater drain tank level control valves are evaluated for controlling margin. Acceptable control margin corresponds to a valve position of less than 50% open, so that each operating valve maintains the ability to pass all of the drain flow.

Table D7-7: Heater Drain Level Control Valve Evaluation

	Acceptance Criteria	Valve Position (% Open)		Δ (30%)
		0%	30%	
HD Level Control Valve	$\leq 50\%$	26.0	16.9	-35.1%

Based on these results, the HD tank level control valves meet the acceptance criteria, and the margin improves for the 30% extraction case.

D8.0 RESULTS AND CONCLUSIONS

Analysis of the power train pumps for the 30% thermal extraction scenario shows that overall, changes from the baseline operating conditions are minimal. Pump operating point changes by less than 5% for all pumps except for the heater drain pumps which see a reduction in percent BEP of ~22%. It is not expected that any equipment changes will be needed to address this, but the HDPs will have to be evaluated with plant-specific operating conditions and design margins. Changes to pump driver duty are also small. However, the duty on the CDPs and CBPs increase and will need to be evaluated against the rated horsepower of their associated drivers on a plant-specific basis. The CBPs also require plant-specific evaluation due to a ~17% decrease in NPSH ratio. The CDP and HDPs NPSH ratios are also decreasing by a small amount. The NPSH ratio for the TDFPs significantly improves. Therefore, although no physical changes are expected the CDPs, CBPs, and HDPs, they should be evaluated for acceptance on a plant-specific basis for the 30% extraction case.

Pump suction pressures decrease for all power train pumps and will need to be evaluated against existing low alarm setpoints on a plant-specific basis.

The feedwater and heater drain flows are reduced, so margins for the feedwater pump turbine speed and heater drain tank level control valves improve for the thermal extraction case.

Attachment E – Moisture Separator Reheater Evaluation with 30% Thermal Energy Extracted

Prepared: Gabriel Neimark

Reviewed: Nic Richards

E1.0 PURPOSE

The purpose of this evaluation is to examine expected changes to operating conditions of the Moisture Separator Reheaters (MSRs). These changes are due to steam extraction for supplying thermal energy off-site. This evaluation is done for the scenario where 30% thermal energy is extracted from the main steam.

E2.0 SYSTEM & COMPONENT DESCRIPTION

The MSRs take wet exhaust steam from the High Pressure Turbine (HPT) and pass it through a series of chevrons to remove moisture. The steam then goes through two stages of heat exchangers where it is heated before being sent to the Low Pressure Turbines (LPTs).

E3.0 METHODOLOGY

The operating conditions of the MSRs are evaluated for the 30% thermal extraction scenario and compared to baseline (0% thermal extraction) operation. These operating conditions are taken from the PEPSE Heat Balance results documented in Attachment A. Evaluation of the MSR drains is done in Attachment H.

E4.0 ASSUMPTIONS

None

E5.0 DESIGN INPUTS

Operating conditions are taken from the PEPSE Heat Balance results documented in Attachment A and presented in Table E7-1.

E6.0 REFERENCES

None

E7.0 EVALUATIONS

The MSR operating conditions for the baseline and 30% thermal extraction scenarios are compared in Table E7-1.

Table E7-1: MSR Operating Conditions

Description	Units	0%	30%	Δ (30%)
MSR Removal Effectiveness	-	0.95	0.95	0.00%
MSR Chevrons Inlet Flow	lbm/hr	3,151,396	2,266,680	-28.1%
MSR Chevrons Inlet Enthalpy	BTU/lbm	1,104	1,115	1.02%
MSR Chevrons Inlet Pressure	psia	190.3	140.2	-26.3%
MSR 1st Stage Inlet Enthalpy	BTU/lbm	1,193	1,189	-0.31%
MSR 1st Stage Inlet Pressure	psia	184.6	136.0	-26.3%

Attachment E

Moisture Separator Reheater Evaluation – 30% Thermal Extraction

Description	Units	0%	30%	Δ (30%)
MSR 2nd Stage Inlet Enthalpy	BTU/lbm	1,227	1,222	-0.41%
MSR 2nd Stage Inlet Pressure	psia	181.8	134.0	-26.3%

As shown in Table E7-1, flow to the MSRs and the pressure at each stage is reduced for the 30% thermal extraction case, with minimal change in enthalpies. Therefore, it is not expected that the MSRs will be negatively impacted by operating with thermal extraction conditions. The ~28% reduction in mass flow results in conditions similar to normal 75% thermal power with no thermal energy extraction.

E8.0 RESULTS AND CONCLUSIONS

The moisture separator reheaters will not be affected by operating under thermal extraction conditions. Pressures and steam flows decrease such that operating conditions are similar to 75% thermal power conditions which is an acceptable operating point for the MSRs.

Attachment F – Feedwater Heater Evaluation with 30% Thermal Energy Extracted

Prepared: Gabriel Neimark

Reviewed: Nic Richards

F1.0 PURPOSE

The purpose of this evaluation is to examine required duty and expected changes to operating conditions and performance parameters in relation to the design of the Feedwater Heaters. These changes are due to extracting steam from the nuclear power cycle main steam system to supply thermal energy to the plant boundary for off-site use. These evaluations are done for the scenario where 30% thermal energy is extracted.

F2.0 SYSTEM & COMPONENT DESCRIPTION

The Condensate (CD) and Feedwater (FW) Systems deliver feedwater (condensed steam) to the steam generators. The CD system first directs flow through three parallel strings of low pressure feedwater heaters (1st point external drain cooler and 1st through 4th point heaters). Flow then passes through two parallel strings of low pressure feedwater heaters (5th point external drain cooler, 5th and 6th point heaters) to the turbine driven steam generator feed pumps (SGFP). FW flow then continues through two parallel high pressure feedwater heaters (7th point heaters) to the steam generators. The feedwater heaters receive extraction steam flow and moisture separator reheater drain flow from the main turbine system.

F3.0 METHODOLOGY AND ACCEPTANCE CRITERIA**F3.1 Methodology****F3.1.1 Tube Side Nozzle Velocity**

The water velocity in these nozzles must be limited to minimize metal erosion in the head and tube sheet areas caused by feedwater impingement. The velocity used with the HEI guidelines [Ref. F6.2] is based on the density of liquid water at 60°F.

F3.1.2 Tube Velocity

In order to avoid excessive tube erosion, the tube velocity should be limited. The flow area is based on the total number of tubes for each pass minus the number of plugged tubes. In accordance with HEI guidelines [Ref. F6.2], the density used in computing the tube velocity is based on the density of liquid water at the average tube temperature.

F3.1.3 Tube Side Pressure Drop and Partition Plate Differential Pressure

The tube side pressure drop principally affects two design issues, (i) the differential pressure across the pass partition plate (PPP), and (ii) the total pressure drop in the feedwater train. The pass partition plate is integral to the head of the feedwater heater, and separates the fluid entering the first tube pass from the fluid exiting the second tube pass. Moderately high differential pressures across the PPP can cause cracking of the welds in the plate or displacement of the partition gasket, which results in leakage and reduced heater performance. No guidelines are stated in HEI for the differential pressure across the PPP. Additional pressure loss in the feedwater train impacts the power train pumps, which are evaluated in Attachment D.

HEI [Ref. F6.2] provides an approximate method of calculating total tube side pressure drop, which consists of the sum of the following terms (see definitions below):

$$\Delta P_{total} = \Delta P_{tubes} + \Delta P_{NI} + \Delta P_{NO} + \Delta P_E \quad (Eq. F3-1)$$

where:

- ΔP_{total} -total tube side pressure drop, psid
- ΔP_{tubes} -pressure loss through tubes, psid
- ΔP_{NI} -pressure loss through channel inlet nozzle, psid
- ΔP_{NO} -pressure loss through channel outlet nozzle, psid
- ΔP_E -tube entrance, exit, and turning losses, psid

Pressure loss across inlet channel and outlet nozzle do not impact the pressure loss across the pass partition plate. Therefore, only the pressure loss through the tubes and the tube entrance, exit, and turning losses impact the PPP pressure drop.

These pressure drops are defined as follows from the HEI standards [Ref. F6.2]:

ΔP Inside Tubes

$$\Delta P_{tubes} = \frac{1.396 \times 10^{-7}}{C} \cdot f \cdot \left(\frac{w}{A_t} \right)^2 \cdot \frac{L}{d} \quad (Eq. F3-2)$$

where:

$$f = 0.0014 + 0.125 \cdot Re^{-0.32}$$

$$Re = \frac{w \cdot d}{0.201389 \cdot \mu \cdot A_t}$$

Tube Entrance, Exit, and Turn Losses

$$\Delta P_E = \frac{2.896 \times 10^{-9}}{C} \cdot K_t \cdot \left(\frac{w}{A_t} \right)^2 \cdot \frac{N}{2} \quad (Eq. F3-3)$$

where:

w	- feedwater mass flow rate, lb _m /hr
L	- total length of tube travel, ft
A_t	- flow area of tubes per pass accounting for tube plugging, in ²
d	- nominal inside diameter of tubes, in
C	- density correction factor from Fig. 3a [Ref. F6.2]
f	- friction factor
K_t	- loss correction factor for tube configuration from Fig. 3b [Ref. F6.2]
N	- number of tube passes
Re	- Reynolds number for individual tube at calculated flow rate per tube
μ	- tube side absolute viscosity, centipoise

Review of Equations F3-2 and F3-3 show most factors are based on the physical design of the FWH and are not sensitive to changes in operating conditions. The density correction factor and friction factor are slightly impacted, but over the range of operating conditions expected, the impact is inconsequential compared to the change in feedwater mass flow rate (which is a squared term). Therefore, to review the impact on PPP pressure loss, only the change in mass flow rate squared is reviewed.

F3.1.4 Steam Inlet and Drain Outlet Nozzle Velocity

Steam velocities entering the shell side of the heater must be limited in order to prevent overstressing of the impingement plate, erosion damage (i.e., to the impingement plate, tube support plates, and heater shell) and to control vibration of the tubes in the high velocity regions where steam is introduced to the tube bundle. Steam velocity is based on the fluid conditions from the heat balance, and it is compared against the recommended limit from the HEI standard [Ref. F6.2].

The steam velocity entering the heater is the mass flow rate of steam entering the heater from the heat balance, divided by the density of the steam, divided by the flow area of a single steam inlet nozzle, divided by the number of steam inlet nozzles per heater.

The velocity in the condensate drain outlet nozzle is calculated as the mass flow rate from the heat balance, divided by the density of liquid discharging from the heater, divided by the flow area of the drain nozzle.

F3.1.5 Drain Inlet Nozzle Mass Flux

The limits for this parameter are provided to minimize and/or avoid the following:

- erosion of the inlet nozzle and heater shell areas adjacent to the nozzle,
- structural damage to the impingement plate and adjacent tube support plates,
- tube degradation in the areas adjacent to the impingement plate, and
- vibration of tubes in high velocity regions where the two-phase mixture is introduced to the tube bundle.

HEI characterizes the inlet conditions through the use of a mass flux parameter, which is equal to the square of the mass flux rate divided by the fluid inlet density. The density is evaluated using the inlet enthalpy and heater shell pressure from the heat balance.

F3.1.6 Operating Pressure and Temperature

Tube side and shell side operating temperatures and shell side pressures for the baseline and 30% thermal extraction case are compared to determine the impact on design value margin. These parameters are taken from the heat balances in Attachment A.

F3.1.7 Drain Cooler Tube Vibration

The main sources of vibration in drain coolers are vortex shedding and fluidelastic whirling [Ref. F6.3]. In order to prevent resonant tube vibration from vortex shedding, the natural frequency of the unsupported tube span should remain larger than the vortex shedding frequency. TEMA requires that the natural frequency exceed the vortex shedding frequency. The natural frequency of the tube span is dependent on the physical design of the FWH and is therefore not impacted by changes to operating conditions associated with operating with thermal power extraction. The vortex shedding frequency is proportional to the cross flow velocity at the tubes. Since the cross flow area will not change with thermal power extraction, the total volumetric drain cooler flow is reviewed for changes due to operation with 30% thermal energy extraction.

Another possible mechanism for vibrational damage is fluidelastic whirling. This process occurs when the displacement of one tube alters the flow field resulting in forces on other tubes. If the exciting force from the flowing fluid exceeds damping, the self-excited vibration will set up. In order to prevent this excitation, the critical whirling velocity must exceed the cross flow velocity. The critical velocity is calculated using the methodology of TEMA [pages 94 & 95, Ref. F6.3].

A review of the TEMA equations shows that the critical velocity is based on physical parameters with a minor relationship to density. As the density is not significantly changing in the drain cooler due to operation with thermal power extraction, critical velocity can be considered constant for the purposes of this evaluation. Therefore, as with vortex shedding, only the cross flow velocity will be impacted by reviewing the total volumetric drain cooler flow changes due to operation with 30% thermal energy extraction.

F3.2 **Acceptance Criteria**

F3.2.1 Acceptance Criterion 1 – Tube side nozzle velocity should be less than 10 ft/s, according to HEI [Ref. F6.2].

F3.2.2 Acceptance Criterion 2 – Tube velocity should be less than 10 ft/s, according to HEI [Ref. F6.2].

F3.2.3 Acceptance Criterion 3 – Steam inlet nozzle velocity should be less than the HEI recommendation:

$$V \leq \frac{250}{P_{STEAM}^{0.09}} \quad (\text{Eq. F3-4})$$

F3.2.4 Acceptance Criterion 4 – Condensate drain outlet velocity should be less than the HEI recommendation [Ref. F6.2] as follows:

- 4 ft/sec for sub-cooled drains,
- 4 ft/sec for saturated drains with level control in the heater, and
- 2 ft/sec for saturated drains where the level is not controlled in the heater

Velocity in the heater drain outlet nozzle must be limited to (a) avoid excessive drag loads on drain cooler tubes in the vicinity of the nozzle, and (b) prevent flashing in the downstream piping connected to the heater outlet nozzle.

F3.2.5 Acceptance Criterion 5 – Drain inlet nozzle mass flux G should be limited to the following according to HEI [Ref. F6.2]:

$$G \leq 250 \text{ lb}_m/\text{sec}/\text{ft}^2 \quad (\text{Eq. F3-5})$$

$$\frac{G^2}{\rho} \leq 4000 \text{ lb}_m/\text{ft}/\text{sec}^2 \quad (\text{Eq. F3-6})$$

F3.2.6 Acceptance Criterion 6 – In order to be acceptable for tube vibration, the following criteria must be met:

- $f_n/f_e > 1$, in order to prevent resonant vortex shedding frequencies [Ref. F6.3]
- $V_{crit}/V > 1$, in order to prevent excessively large vibration amplitudes [Ref. F6.3]

As discussed in Section F3.1.7, the natural frequency and critical velocity can be considered constant relative to changes in operating conditions. Similarly, the vortex shedding frequency and cross flow velocity are directly proportional to drain cooler volumetric flow. Therefore, if drain cooler volumetric flow decreases, margins to the ratio criteria will increase.

F4.0 ASSUMPTIONS

None.

F5.0 DESIGN INPUTS

F5.1 Operating Conditions – Mass flow rates, pressures, temperatures, and enthalpies for various operating parameters are taken from the PEPSE results given in Attachment A.

F5.2 Feedwater Heater Tubes – The number of tubes, tube dimensions, total length of tube travel, design tube pressure drop, and percent tube plugging are given in Table F5-1 based on typical plant data.

Table F5-1: FWH Tube Side Dimensions

Heater Nos	# of Tubes	Tube Size	Thickness (in)	Tube I.D. (in)	Total Tube Length (ft)	Pressure Drop (psi)	Tube Plugging (-)
1 st EDC	396	1	0.035	0.930	15' 5"	6.6	15%
1 st Point	1201	5/8	0.035	0.555	33' 8"	15	5%
2 nd Point	797	3/4	0.035	0.680	46' 11"	15.7	5%
3 rd Point	767	3/4	0.035	0.680	42' 7"	15.1	5%
4 th Point	673	7/8	0.035	0.805	39' 7"	8.6	5%
5 th EDC	2798	5/8	0.035	0.555	13' 8"	3.1	15%
5 th Point	1842	3/4	0.035	0.680	29' 3"	10.5	5%
6 th Point	2037	3/4	0.035	0.680	33' 3"	9.4	5%
7 th Point	3583	5/8	0.058	0.509	24' 2"	10.9	5%

F5.3 Nozzle Sizes – The heater nozzle dimensions and the number of nozzles of each type are given in Table F5-2 based on typical plant data.

Table F5-2: FWH Nozzle Sizes

Heater Nos	Feedwater Inlet Nozzles		Feedwater Outlet Nozzles		Extraction Steam Nozzles			Inlet Drain Nozzles		Outlet Drain Nozzles	
	Dia (in)	I.D. (in)	Dia (in)	I.D. (in)	Qty.	Dia (in)	I.D. (in)	Dia (in)	I.D. (in)	Dia (in)	I.D. (in)
1 st EDC	18"	16.12	18"	16.12	-	-	-	18"	17.250	18"	17.25
1 st Point	18"	16.12	18"	16.12	4	30"	29.00	-	-	10"	10.02
2 nd Point	18"	16.12	18"	16.12	2	28"	27.00	12"	11.750	14"	13.25
3 rd Point	18"	16.12	18"	16.12	2	18"	17.00	8"	7.625	12"	12.00
4 th Point	18"	16.12	18"	16.12	1	20"	19.00	-	-	8"	7.98
5 th EDC	24"	21.56	24"	21.56	-	-	-	30"	29.250	30"	29.25
5 th Point	28"	26.13	28"	26.13	1	22"	20.25	See Note 1	See Note 1	26"	25.25
6 th Point	28"	26.13	28"	26.13	1	18"	16.88	18"	17.00	20"	19.25
7 th Point	28"	25.4	24"	20.4	1	14"	13.12	10" (x2)	9.562	18"	17.25

¹The fifth point FWHs have an 18-inch nozzle for cascading FWH drains (ID = 17.000") and two 8-inch nozzle for drains from each first stage reheater drain tank (ID = 7.625").

F6.0 REFERENCES

- F6.1 STMFUNC (Steam Table Function Dynamic Link Library) S&L Program Number 03.7.598 2.0, dated 06-11-2018.
- F6.2 Standards for Closed Feedwater Heaters. Heat Exchange Institute, Inc. Sixth Edition, 1998.
- F6.3 Standards of the Tubular Exchanger Manufacturers Association, Tubular Exchanger Manufacturers Association, Inc. Seventh Edition, 1988.

F7.0 EVALUATIONS**F7.1 Evaluation of Condensate/Feedwater Nozzle Velocities**

The following channel end nozzle velocities were computed for the feedwater heaters.

Table F7-1: Condensate/Feedwater Heater Nozzle Velocities (ft/s)

FW Heater	HEI Limit	Baseline (0% Extraction)	30% Extraction	Δ (30%)
1 st EDC	10	11.9	12.3	3.4%
1 st Point	10	11.9	12.3	3.4%
2 nd Point	10	11.9	12.3	3.4%
3 rd Point	10	11.9	12.3	3.4%
4 th Point	10	11.9	12.3	3.4%
5 th EDC	10	10.0	10.3	3.4%
5 th Point	10	9.6	9.2	-3.7%
6 th Point	10	9.6	9.2	-3.7%
7 th Point Inlet	10	10.2	9.8	-3.7%
7 th Point Outlet	10	15.8	15.2	-3.7%

Tube side nozzle velocities exceed the HEI guidelines for the several of the FWHeaters but changes from the baseline case are small or decrease, and it is not expected that feedwater nozzle wear will be an issue due to these changes.

F7.2 Evaluation of Tube Velocities

The following tube velocities were computed for the feedwater heaters. They are based on the density using the average tube temperature.

Attachment F
Feedwater Heater Evaluation – 30% Thermal Extraction

Table F7-2: Tube Velocity (ft/s)

FW Heater	HEI Limit	Baseline (0% Extraction)	30% Extraction	Δ (30%)
1 st EDC	10	10.7	11.0	3.1%
1 st Point	10	8.9	9.2	3.0%
2 nd Point	10	9.1	9.3	2.7%
3 rd Point	10	9.6	9.9	2.5%
4 th Point	10	8.1	8.2	2.2%
5 th EDC	10	7.0	7.1	2.0%
5 th Point	10	9.1	8.6	-5.2%
6 th Point	10	8.5	8.0	-5.4%
7 th Point	10	8.8	8.3	-5.8%

Tube velocities remain below or marginally exceed the HEI guidelines for the 30% thermal extraction case. Because changes are small, it is not expected that this will impact FWH tube degradation.

F7.3 Tube Side Pressure Drop

The following change in mass flow rates are used to evaluate the impact on PPP pressure loss based on the methodology outlined in Section 3.1.3. As the mass flow rate term is squared in the pressure loss equations, the ratio of flow rates is squared to determine the percent change in PPP pressure drop.

Table F7-3: Pass Partition Plate Pressure Loss

FW Heater	Baseline (0% Extraction) (lbm/hr)	30% Extraction (lbm/hr)	Ratio of Flow Rates (30%/Baseline)	Ratio of Flow Rates Squared (30%/Baseline) ²	PPP dP % Change
1 st EDC	3,778,163	3,907,940	103%	107%	7.0%
1 st Point	3,778,163	3,907,940	103%	107%	7.0%
2 nd Point	3,778,163	3,907,940	103%	107%	7.0%
3 rd Point	3,778,163	3,907,940	103%	107%	7.0%
4 th Point	3,778,163	3,907,940	103%	107%	7.0%
5 th EDC	5,667,245	5,861,910	103%	107%	7.0%
5 th Point	8,033,640	7,733,095	96%	93%	-7.3%
6 th Point	8,033,640	7,733,095	96%	93%	-7.3%
7 th Point	8,033,640	7,733,095	96%	93%	-7.3%

Attachment F
Feedwater Heater Evaluation – 30% Thermal Extraction

The pressure loss across the PP is expected to increase in FWHe 1 through 4 and both external drain coolers. However, the expected increase in tube side pressure drop for the thermal extraction case is not expected to appreciably impact reliable operation of the heaters.

F7.4 Steam Inlet and Drain Outlet Nozzle Velocity

The following steam inlet and drain outlet nozzle velocities were computed for the feedwater heaters.

Table F7-4: Steam Inlet Nozzle Velocity (ft/s)

FW Heater	HEI Limit	Baseline (0% Extraction)	30% Extraction	Δ (30%)
1 st Point	215	137	181	32.6%
2 nd Point	195	148	206	38.9%
3 rd Point	179	179	249	39.1%
4 th Point	167	156	214	37.5%
5 th Point	156	101	115	37.2%
6 th Point	150	103	139	19.8%
7 th Point	146	80	123	5.39%

Table F7-5: Drain Outlet Nozzle Velocity (ft/s)

FW Heater	HEI Limit	Baseline (0% Extraction)	30% Extraction	Δ (30%)
1 st EDC	4.0	2.3	2.1	-9.13%
1 st Point	4.0	1.8	1.5	-20.2%
2 nd Point	4.0	2.9	2.7	-5.49%
3 rd Point	4.0	2.4	2.3	-3.27%
4 th Point	4.0	2.8	2.7	-3.63%
5 th EDC	4.0	1.8	1.5	-14.1%
5 th Point	4.0	2.5	2.1	-14.3%
6 th Point	4.0	2.7	2.3	-13.7%
7 th Point	4.0	2.2	1.9	-13.6%

Steam inlet nozzle velocities for the thermal extraction case increase for all FWHe and exceed the HEI guideline for the 2nd, 3rd and 4th point heaters. Shell wear rates will likely increase, and it should be noted that changes to steam inlet velocity can affect the wear pattern of the shell, and future inspections should be mindful for changes.

Drain outlet velocities decrease for the thermal extraction case, so HEI guidelines are not challenged, and wear rates may decrease.

F7.5 Drain Inlet Nozzle Mass Flux

The mass flux and mass flux parameter of flashing condensate flows entering the shell side of the feedwater heaters are as follows:

Table F7-6: Heater Drain Inlet Nozzle Mass Flux and Mass Flux Parameter

FW Heater	Mass Flux (lbm/s/ft ²)				Mass Flux Parameter (lbm/ft/s ²)			
	HEI Limit	Baseline (0% Extraction)	30% Extraction	Δ (30%)	HEI Limit	Baseline (0% Extraction)	30% Extraction	Δ (30%)
1 st EDC	250	141	129	-8.9%	4,000	4,755	4,110	-13.6%
2 nd Point	250	148	144	-2.4%	4,000	6,491	7,214	11.1%
3 rd Point	250	179	174	-2.5%	4,000	4,141	4,741	14.5%
5 th EDC	250	102	89	-12.9%	4,000	190	142	-25.3%
5 th Point (cascading)	250	188	165	-12.2%	4,000	647	490	-24.3%
5 th Point (MSR)	250	119	79	-33.2%	4,000	4409	2,414	-45.2%
6 th Point	250	118	104	-11.7%	4,000	515	404	-21.7%
7 th Point	250	112	107	-3.9%	4,000	2,177	3,231	48.4%

Drain inlet mass fluxes remain below HEI guidelines, but the mass flux parameters for various heaters exceed the guidelines for the thermal extraction case. For most FWHs, however, the mass flux parameter decreases, or the increase is small (<15%). The FWH 7 inlet mass flux parameter increases by nearly 50% due to the change in density from the lower shell pressure. If the subject station does not show sufficient margin to allow for this increase, the additional flashing steam could increase wear rates at the drain inlet and future inspections should be mindful for changes.

F7.6 Operating Pressure and Temperature

Shell side operating pressure and tube side and shell side operating temperatures are compared for the baseline and 30% thermal extraction cases in Tables F7-7 through F7-9. The shell side operating temperature is the saturation temperature of steam at the operating shell side pressure.

Attachment F
Feedwater Heater Evaluation – 30% Thermal Extraction

Table F7-7: Shell Side Operating Pressures (psia)

FW Heater	Baseline (0% Extraction)	30% Extraction	Δ (30%)
1 st EDC	5.4	3.6	-33.0%
1 st Point	5.4	3.6	-33.0%
2 nd Point	15.9	10.8	-32.0%
3 rd Point	40.6	28.2	-30.6%
4 th Point	89.5	64.5	-28.0%
5 th EDC	186.1	137.1	-26.3%
5 th Point	186.1	137.1	-26.3%
6 th Point	287.1	212.7	-25.9%
7 th Point	408.7	303.0	-25.9%

Table F7-8: Shell Side Operating Temperatures (°F)

FW Heater	Baseline (0% Extraction)	30% Extraction	Δ (30%)
1 st EDC	165.6	149.0	-16.6°F
1 st Point	165.6	149.0	-16.6°F
2 nd Point	215.9	196.8	-19.1°F
3 rd Point	268.1	246.7	-21.4°F
4 th Point	319.9	297.4	-22.4°F
5 th EDC	375.8	351.4	-24.4°F
5 th Point	375.8	351.4	-24.4°F
6 th Point	413.3	387.0	-26.3°F
7 th Point	446.7	418.3	-28.4°F

Table F7-9: Tube Side Operating Temperatures (°F)

FW Heater	Baseline (0% Extraction)	30% Extraction	Δ (30%)
1 st EDC	126.6	113.5	-13.1°F
1 st Point	161.7	144.8	-16.9°F
2 nd Point	212.8	192.6	-20.2°F
3 rd Point	265.0	243.3	-21.7°F
4 th Point	316.4	293.5	-22.9°F
5 th EDC	332.2	306.8	-25.4°F
5 th Point	370.2	345.9	-24.3°F

Attachment F
Feedwater Heater Evaluation – 30% Thermal Extraction

FW Heater	Baseline (0% Extraction)	30% Extraction	Δ (30%)
6 th Point	409.7	383.7	-25.9°F
7 th Point	441.5	413.8	-27.7°F

Operating temperatures and pressures decrease for all FWHs, so margins with design values will improve for the thermal extraction case.

F7.7 Drain Cooler Tube Vibration

Tube vibration in the 1st through 7th point heater drain coolers is evaluated by comparing the drain cooler volumetric flow rates.

Table F7-10: Drain Cooler Vibration

FW Heater No.	Drain Volumetric Flow (gpm)		
	Baseline (0% Extraction)	30% Extraction	Δ (30%)
1 st EDC	1,671	1,518	-9.1%
2 nd Point	1,240	1,172	-5.5%
3 rd Point	842	814	-3.3%
4 th Point	439	423	-3.6%
5 th EDC	3,767	3,235	-14.1%
6 th Point	2,434	2,100	-13.7%
7 th Point	1,578	1,363	-13.6%

As shown in Table F7-10, the volumetric flow through all drain coolers is expected to decrease during operation with 30% thermal extraction, resulting in increased margin for tube vibration parameters. Therefore, tube vibration is not expected to be caused by operating with thermal extraction.

F8.0 RESULTS AND CONCLUSIONS

Tube and tube side nozzle velocities exceed the HEI guidelines for several of the FWHs, but changes from the baseline case are small or decrease, so it is not expected that FWH tube degradation or nozzle wear will be an issue due to thermal extraction. Steam inlet nozzle velocities for the thermal extraction case increase for all FWHs and exceed the HEI guideline for the 2nd, 3rd and 4th point heaters, so shell wear rates will likely increase. It should also be noted that changes to steam inlet velocity can affect the wear pattern of the shell, and future inspections should be mindful for changes. Drain outlet velocities decrease for the thermal extraction case, so HEI guidelines are not challenged, and wear rates may decrease.

Attachment F
Feedwater Heater Evaluation – 30% Thermal Extraction

The pressure loss across the pass partition plate is expected to increase in FWHs 1 through 4 and both external drain coolers. However, the expected increase in tube side pressure drop for the thermal extraction case is not expected to appreciably impact reliable operation of the heaters.

Drain inlet mass fluxes remain below HEI guidelines, but the mass flux parameters for various heaters exceed the guidelines for the thermal extraction case. For most FWHs, however, the mass flux parameter decreases, or the increase is small (<15%). The FWH 7 inlet mass flux parameter increases by nearly 50% due to the change in density from the lower shell pressure. If the subject station does not show sufficient margin to allow for this increase, the additional flashing steam could increase wear rates at the drain inlet and future inspections should be mindful for changes.

Operating temperatures and pressures decrease for all FWHs, so margins with design values will improve for the thermal extraction case. Volumetric flow through all drain coolers is also expected to decrease during operation with 30% thermal extraction, resulting in increased margin for tube vibration parameters. Therefore, tube vibration is not expected to be caused by operating with thermal extraction.

Attachment G - Extraction Steam Evaluation with 30% Thermal Energy Extracted

Prepared: Gabriel Neimark

Reviewed: Nic Richards

G1.0 PURPOSE

The purpose of this evaluation is to examine expected changes to operating conditions and performance parameters in relation to the design of the Extraction Steam (ES) System. These changes are due to operation with 30% thermal energy extracted from the main steam.

G2.0 SYSTEM & COMPONENT DESCRIPTION

To maximize steam cycle efficiency, the ES System diverts steam taken from the turbine to the feedwater heaters. There are three stages of extraction from the High Pressure (HP) turbine, and four stages of extraction from each Low Pressure (LP) turbine. The Extraction Steam is used to heat the feedwater in seven separate feedwater heater stages.

There are three trains for the 1st through 4th point LP feedwater heaters, two trains for the 5th and 6th point LP feedwater heaters, and two trains for the 7th point HP feedwater heater.

G3.0 METHODOLOGY**G3.1 Methodology****G3.1.1 Extraction Steam Lines Pressure Drop**

Pressure drop in the ES lines will be evaluated using simplified incompressible flow methodology based on the Crane Technical Paper [pp. 3-4, Ref. G6.3]. The following equation will be utilized to estimate the ES lines pressure drop:

$$\Delta P = 2.80 \times 10^{-7} \frac{KW^2v}{d^4} \quad \text{Eq. G3-1}$$

where:

- ΔP = Pressure Drop [psi]
- K = Resistance Coefficient [ul]
- W = Mass Flow Rate [lbm/hr]
- v = Specific Volume [ft³/lbm]
- d = Piping Inside Diameter [in]

The K value for each segment of the ES piping, the saturation pressures of each feedwater heater shell, and the total mass flow rate of the ES from the PEPSE evaluation in Attachment A will be used to compute the pressure drop for each available line.

G3.1.2 Operating Conditions

ES line pressures and temperatures from the PEPSE analysis in Attachment A are compared for the baseline and 30% thermal extraction scenarios. These comparisons are used to generalize the impacts on relevant valve and expansion joint service conditions.

G3.1.3 Extraction Steam Expansion Joint Liner Thickness

The required expansion joint liner thicknesses for the baseline and 30% extraction cases are calculated using the following methodology and compared. Based on Section 4.10.2 of the EJMA standard [Ref. G6.1], the minimum liner thickness for expansion joints between 12 to 24-inch diameters is 0.048-in and 0.060-in for diameters of 26 to 48-in. When the internal sleeve length exceeds 18-in, the standard liner thickness is to be multiplied by $(L/18)^{0.5}$ where L is the internal sleeve length in inches. When the flow velocity exceeds 100 ft/sec, the standard liner thickness is to be multiplied by $(V/100)^{0.5}$ where V is the liner velocity and is computed by (equation per page 3-2, [Ref. G6.3]):

$$V = 0.0509 \frac{Wv}{d^2} \quad \text{Eq. G3-2}$$

where:

- V = Mean Velocity of Flow [ft/sec]
- W = Mass Flow Rate [lb_m/hr]
- v = Specific Volume [ft³/lb_m]
- d = Piping Inside Diameter [in]

Where extremely turbulent flow is generated within 10 pipe diameters upstream of the expansion joint by valves, tees, and elbows, the flow velocity used in calculating the liner thickness shall be determined by multiplying the actual flow velocity by four [Ref. G6.1]. Since the expansion joint assemblies have high Reynolds's numbers, the 'turbulent flow multiplier' is used.

When the fluid temperature exceeds 300°F, the thickness increase factor shall be equal to E_{sc}/E_{sh} where E_{sc} is the internal sleeve modulus of elasticity at 300°F and E_{sh} is the internal sleeve modulus of elasticity at the media temperature [Ref. G6.1]. The only extraction line that experiences temperatures above 300°F is FWH 4 and the change in modulus of elasticity due to temperature change at baseline to 30% thermal power extraction conditions is expected to be negligible. Therefore, the temperature increase factor is ignored.

G4.0 ASSUMPTIONS

G4.1 Pressure Drop – Pressure loss is computed based on incompressible flow equations. Per Crane [Ref. G6.3], if the calculated pressure drop is less than about 10% of the inlet pressure, reasonable accuracy will be obtained if specific volume is based on either upstream or downstream conditions. Similarly, for pressure drop between 10% and 40% of inlet pressure, specific volume based on the average upstream and downstream conditions can be used. For conservatism, the specific volume of steam/steam water mixture is based on the feedwater heater shell pressure and the turbine extraction point enthalpy. Using the end-point pressure to determine specific volume is conservative with respect to pressure drop and line velocity.

G4.2 Flow Rate – It is assumed that the flow rate is equal in all heater trains from the HP Turbine. The flow rate is used as input for the calculation of ES line pressure drop. While some flow variation

between trains may exist, it will affect the losses associated with piping to only a small degree. The piping loss is a very small part of the total line loss, which accounts for losses due to various components such as elbows and valves. Loss factors for these components are typically conservative in nature. Also note that the higher flow from either string from the PEPSE analysis (see Attachment A) is used. This should provide adequate allowance and margin for differences between heater strings.

G5.0 DESIGN INPUTS

G5.1 Operating Parameters

ES flows, temperatures, pressures, and enthalpies are taken from the PEPSE results given in Attachment A. For this analysis, the maximum values for mass flow, pressure, and enthalpy from the three strings for FWHs 1-4 are used. The pressure subscripts 'US' and 'DS' indicate upstream and downstream, respectively. Specific volume is based on downstream pressure, yielding a higher result which is conservative with respect to flow velocity. This is consistent with Assumption G4.1. Temperature is based on upstream pressure, yielding a higher temperature which is conservative with respect to maximum rated temperature for equipment. Both specific volume and temperature are calculated with the Excel STMFUNC add-in [Ref. G6.2].

Table G5-1: Heat Balance Data – 0% Extraction

Parameter	Mass Flow W (lb _m /hr)	Pressure P _{DS} (psia)	Pressure P _{US} (psia)	Enthalpy h (Btu/lb _m)	Spec. Vol v _{DS} (ft ³ /lb _m)	Temp. T _{US} (°F)
HP Turbine to 1 st Stg. Rhtr	1.36E+05	448.7	451.0	1159.0	0.97	456.5
HP Turbine to 7th Stg. FWH	5.16E+05	408.7	451.0	1144.6	1.05	456.5
HP Turbine to 6th Stg. FWH	8.01E+05	287.1	296.5	1114.2	1.44	416.3
HP Turbine to 5th Stg. FWH	7.47E+05	186.1	190.3	1104.0	2.18	377.6
LP Turbine to 4th Stg. FWH	6.13E+05	89.6	92.4	1219.2	5.39	382.5
LP Turbine to 3rd Stg. FWH	5.96E+05	40.6	41.9	1158.8	10.2	270.1
LP Turbine to 2nd Stg. FWH	6.23E+05	15.9	16.4	976.3	20.4	217.7
LP Turbine to 1st Stg. FWH	6.63E+05	5.4	5.4	730.6	40.7	165.7

Table G5-2: Heat Balance Data – 30% Extraction

Parameter	Mass Flow W (lb _m /hr)	Pressure P _{DS} (psig)	Pressure P _{US} (psig)	Enthalpy h (Btu/lb _m)	Spec. Vol v _{DS} (ft ³ /lb _m)	Temp. T _{US} (°F)
HP Turbine to 1 st Stg. Rhtr	9.07E+04	335.3	337.0	1171.3	1.33	428.1
HP Turbine to 7th Stg. FWH	3.94E+05	303.0	337.0	1159.7	1.45	428.1
HP Turbine to 6th Stg. FWH	6.96E+05	212.7	219.7	1130.8	1.98	389.8
HP Turbine to 5th Stg. FWH	7.47E+05	137.1	140.2	1115.3	2.99	353.2
LP Turbine to 4th Stg. FWH	5.97E+05	64.6	66.6	1225.6	7.60	386.4
LP Turbine to 3rd Stg. FWH	5.82E+05	28.2	29.1	1162.4	14.5	248.6
LP Turbine to 2nd Stg. FWH	5.65E+05	10.8	11.2	1020.5	31.2	198.5
LP Turbine to 1st Stg. FWH	5.32E+05	3.6	3.6	800.9	67.2	149.1

G5.2 Expansion Joint Design Data

The input used to calculate the expansion joint required liner thickness is given below based on a typical plant configuration.

Table G5-3: Expansion Joint Design Data

Expansion Joint Location	Nom. Dia.	Liner ID	Liner Length
	[in.]	[in.]	[in.]
4 th Point Heater	14	11.75	9.63
3 rd Point Heater	18	15.75	9.75
2 nd Point Heater	28	25.25	9.75
1 st Point Heater	30	27.25	15.25

G5.3 Line Information

The extraction steam piping information used to calculate pressure drop for each line is given below based on a typical plant configuration.

Table G5-4: ES Line Information

	Piping Segment	Pipe ID (in)	Total K
HPT to 7th Stg FWH	Turb Extraction A	13.12	2.491
	Turb Extraction B	13.12	2.772
	Turb Extraction	18.81	3.945
	To Heater 7A	13.12	3.09
	To Heater 7B	13.12	3.342
HPT to 6th Stg FWH	Turb Extraction A	16.88	1.738
	Turb Extraction B	16.88	1.623
	Turb Extraction	22.62	4.204
	To Heater 6A	16.88	3.59
	To Heater 6B	16.88	3.814
HPT to 5th Stg FWH	Turb Extraction A	18.81	2.917
	Turb Extraction B	18.81	2.368
	Turb Extraction	29.00	4.043
	To Heater 5A	22.62	3.179
	To Heater 5B	22.62	3.63
LPT to 4th Stg FWH	Turb Extraction	13.00	2.467
	To Heater 4A	19.00	6.113
	Turb Extraction	13.00	2.467
	To Heater 4B	19.00	5.683
	Turb Extraction	13.00	2.467
	To Heater 4C	19.00	6.141
LPT to 3rd Stg FWH	Turb Extraction	17.00	3.047
	Turb Extraction	23.00	3.518
	To Heater 3A	17.00	2.317
	Turb Extraction	17.00	3.098
	Turb Extraction	23.00	3.45
	To Heater 3B	17.00	2.339
	Turb Extraction	17.00	3.098
	Turb Extraction	23.00	3.5
	To Heater 3C	17.00	2.339
LPT to 2nd Stg FWH	Turb Extraction	27.00	1.872
	Turb Extraction	39.00	3.001
	To Heater 2A	27.00	2.038
	Turb Extraction	27.00	1.872
	Turb Extraction	39.00	3.076
	To Heater 2B	27.00	2.038
	Turb Extraction	27.00	1.872

Attachment G
Extraction Steam Evaluation – 30% Thermal Extraction

	Piping Segment	Pipe ID (in)	Total K
	Turb Extraction	39.00	3.072
	To Heater 2C	27.00	2.056
LPT to 1st Stg FWH	To Heater 1A	29.00	2.439
	To Heater 1A	29.00	2.116
	To Heater 1A	29.00	2.705
	To Heater 1A	29.00	2.345

G6.0 REFERENCES

- G6.1 Standards of the Expansion Joint Manufacturers Association (EJMA), Inc., Ninth Edition, 2008.
- G6.2 STMFUNC (Steam Table Function Dynamic Link Library) S&L Program Number 03.7.598 2.0, dated 06-11-2018.
- G6.3 Crane Technical Paper No. 410, *Flow of Fluids Through Valves, Fittings, and Pipe*, Twenty Fifth Printing, 1991.
- G6.4 Standards of the Expansion Joint Manufacturers Association (EJMA), Inc., Ninth Edition, 2008.

G7.0 EVALUATIONS

G7.1 Pressure Drop

ES line pressure drops are compared for the baseline and 30% thermal extraction scenarios in Table G7-1.

Table G7-1: ES Line Pressure Drop

	Upstream Pressure [psia]			Pressure Drop [psid]		
	0%	30%	Delta	0%	30%	Delta
HPT to 7th Stg FWH	451.0	337.0	-25.3%	6.50	5.24	-19.4%
HPT to 6th Stg FWH	296.5	219.7	-25.9%	8.46	8.82	4.2%
HPT to 5th Stg FWH	190.3	140.2	-26.3%	4.97	6.82	37.4%
LPT to 4th Stg FWH	92.39	66.6	-27.9%	4.33	5.80	33.9%
LPT to 3rd Stg FWH	41.9	29.11	-30.5%	3.24	4.41	35.8%
LPT to 2nd Stg FWH	16.43	11.18	-32.0%	0.78	0.98	25.9%
LPT to 1st Stg FWH	5.428	3.637	-33.0%	0.13	0.14	6.4%

The pressure drop in the lines from the HPT to 7th stage FWHs decreases, but all other extraction steam lines see an increase in pressure drop for the 30% thermal extraction case due to higher flow velocities. The most significant changes are in lines to the 2nd, 3rd, 4th, and 5th stage FWHs which have an increase in pressure drop of greater than 25%.

G7.2 Operating Conditions

ES line pressures and temperatures for the baseline and 30% thermal extraction scenarios are compared in Table G7-2.

Table G7-2: ES Line Operating Conditions

	Line Pressure [psia]			Line Temperature [°F]		
	0%	30%	Delta	0%	30%	Delta
HPT to 1st Stg Rhtr	448.7	335.3	-25.3%	456.50	428.15	-28.4°F
HPT to 7th Stg FWH	408.7	303.0	-25.9%	456.50	428.15	-28.4°F
HPT to 6th Stg FWH	287.1	212.7	-25.9%	416.29	389.77	-26.5°F
HPT to 5th Stg FWH	186.1	137.1	-26.3%	377.64	353.15	-24.5°F
LPT to 4th Stg FWH	89.6	64.6	-27.9%	382.52	386.44	3.9°F
LPT to 3rd Stg FWH	40.6	28.2	-30.5%	270.06	248.61	-21.4°F
LPT to 2nd Stg FWH	15.9	10.8	-32.0%	217.68	198.51	-19.2°F
LPT to 1st Stg FWH	5.4	3.6	-33.0%	165.73	149.10	-16.6°F

Pressures and temperatures decrease for the thermal extraction case in all lines other than a small temperature increase (<5°F) in the 4th Stg FWH line. Based on these results, margins for design pressures and temperatures will largely improve for relevant valves and expansion joints.

G7.3 Expansion Joint Required Liner Thickness

Required liner thicknesses for the baseline and 30% thermal extraction scenarios are compared in Table G7-3.

Table G7-3: Expansion Joint Required Liner Thickness

	Required Liner Thickness [in]		
	0%	30%	Delta
LPT to 4th Stg FWH	0.137	0.160	17.2%
LPT to 3rd Stg FWH	0.138	0.163	17.9%
LPT to 2nd Stg FWH	0.156	0.184	17.8%
LPT to 1st Stg FWH	0.149	0.172	15.1%

Liner thickness requirements increase for the thermal extraction case. Existing expansion joints will need to be evaluated on a plant-specific basis and may need to be replaced to ensure they meet these new requirements.

G8.0 RESULTS AND CONCLUSIONS

Analysis of the extraction steam system for the 30% thermal extraction scenario shows that overall, extraction steam line pressure drops increase due to higher flow velocities, with lines to the 2nd, 3rd, 4th, and 5th stage feedwater heaters seeing an increase of over 25%. Expansion joint liner thickness requirements also increase by up to ~18%, and existing expansion joints will need to be evaluated on a plant-specific basis and may need to be replaced to ensure they meet these new requirements.

Pressures and temperatures mostly decrease during operation with thermal extraction, so margins for design pressures and temperatures will largely improve for valves and expansion joints in the extraction steam system. The only exception is a slight temperature increase (<5°F) in the 4th Stage FWH extraction line. This slight increase is expected to be within the design margin of a typical plant.

Attachment H – Heater Drain System Assessment with 30% Thermal Energy Extracted

Prepared: Nic Richards

Reviewed: Pawel Kut

Attachment H
Heater Drain System Assessment – 30% Thermal Extraction

H1.0 PURPOSE

The purpose of this appendix is to assess the heater drain system performance and expected changes to operating conditions due to operation with 30% turbine cycle thermal energy extracted from the main steam.

H2.0 SYSTEM & COMPONENT DESCRIPTION**H2.1 System Description**

There are seven stages of feedwater heating for normal operations. Two parallel trains ('A' and 'B' trains), each consisting of a feedwater heater (FWH) 5, 6 and 7, are available for normal operation. Drains cascade back to the heater drain tank (HDT) starting at FWH 7. Flow for each train passes through the FWH 5 external drain coolers before entering the HDT. Emergency drains to the condenser are available for FWHs 5, 6, and 7.

Three parallel FWH drain trains ('A' train, 'B' train, and 'C' train), each consisting of a FWH 1, 2, 3, and 4, are available for normal operation. Drains cascade from FWH 4 to the flash tanks through FWHs 3 and 2. FWHs 1 drain to the flash tanks as well. Each flash tank drains to the condenser via the FWH 1 external drain coolers. Emergency drains to the condenser are available for FWHs 4, 3, and 2, as well as the flash tanks.

Four MSR drain trains ('A' train, 'B' train, 'C' train, and 'D' train), each consisting of a moisture separator drain tank (MSDT), 1st stage reheater drain tank (RH1DT), and a 2nd stage reheater drain tank (RH2DT), are available for normal operation as well. The MSDT drains are directed to the HDT. The 1st and 2nd stage reheater drains are directed to FWHs 5 and 7, respectively. Emergency drain lines to the condenser are available for each of the drain lines.

H2.2 Component Description*a) Normal and Emergency Drain Control Valves*

The normal and emergency drain flow paths for each component are described below:

Table H2-1 – Component Flow Path Descriptions

Service	Source	Destination
7 th Point Normal	FWH 7	FWH 6
7 th Point Emergency	FWH 7	Condenser
6 th Point Normal	FWH 6	FWH 5
6 th Point Emergency	FWH 6	Condenser
5 th Point Normal	FWH 5	DC 5
5 th Point Emergency	FWH 5	Condenser
Drain Cooler 5 Normal	DC 5	HDT
Drain Cooler 5 Emergency	N/A	N/A
4 th Point Normal	FWH 4	FWH 3
4 th Point Emergency	FWH 4	Condenser

Attachment H
Heater Drain System Assessment – 30% Thermal Extraction

Service	Source	Destination
3rd Point Normal	FWH 3	FWH 2
3rd Point Emergency	FWH 3	Condenser
2nd Point Normal	FWH 2	Flash Tanks
2nd Point Emergency	FWH 2	Condenser
1st Point Normal	FWH 1	Flash Tanks
1st Point Emergency	N/A	N/A
Flash Tank Normal	Flash Tanks	DC 1
Flash Tank Emergency	Flash Tanks	Condenser
Drain Coolers 1 Normal	DC 1	Condenser
Drain Coolers 1 Emergency	N/A	N/A
HDT Normal	FWH Drain Tank	Condensate Booster System
HDT Emergency	FWH Drain Tank	Condenser
RH2DT Normal	2 nd Stage Drain Tanks	FWH 7
RH2DT Emergency	2 nd Stage Drain Tanks	Condenser
RH1DT Normal	1 st Stage Drain Tanks	FWH 5
RH1DT Emergency	1 st Stage Drain Tanks	Condenser
MSDT Normal	MSR Shell Drain Tanks	HDT
MSDT Emergency	MSR Shell Drain Tanks	Condenser

b) Drain Tanks

Drain tanks are provided to collect condensed steam from the moisture separators, 1st and 2nd stage reheaters, and feedwater heaters. The drain tanks in the HD system include:

- i) Heater Drain Tank
- ii) Moisture Separator Drain Tanks
- iii) 1st Stage Reheater Drain Tanks
- iv) 2nd Stage Reheater Drain Tanks
- v) Flash Tanks

c) Heater Drain Pumps

The HDPs function to pump drains collected in the HDT forward to the condensate system through control valves. There are three 50% capacity HDPs. Normally two pumps operate with a third in standby. These pumps and control valves are evaluated in the Power Train Pumps Assessment (see Attachment D)

Attachment H
Heater Drain System Assessment – 30% Thermal Extraction

H3.0 METHODOLOGY**H3.1 Required Drain Control Valve (DCV) Capacity**

The flow capacity (C_v) of a control valve is a function of the valve body, valve trim, valve stem position, fluid properties of inlet liquid, and downstream backpressure. The methodology for evaluating the capacity is the standard industry method as outlined in the Masoneilan Control Valve Sizing Handbook [Ref. H6.1]. For the evaluations here, the required duty (in lb_m/hr) is taken from the heat balances (see Design Input H5.1). The C_v required of the valve is then determined and the required valve flow coefficient during 30% thermal power extraction operating conditions is compared against the baseline valve C_v to determine the impact operating with thermal power extraction has on the level control valves.

The steps in the determination are as follows:

- Determine the required mass flow rate (see Design Input H5.1 for inputs used).
- Determine the valve inlet water temperature and pressure (see Design Input H5.1 for inputs used).
- Determine valve inlet pressure (see Section H3.1.2).
- Determine the pressure differential at which the valve chokes. This is termed the ‘allowable pressure differential’ as any further decrease in downstream pressure (increase in valve pressure differential) will not increase the mass flow rate through the valve. Required input for this includes the pressure recovery factor (F_L), the inlet pressure (P_1), the critical pressure ratio factor (F_F), and the saturation vapor pressure at the valve inlet (P_v).
- Determine the valve outlet pressure if no choking occurs (see Section H3.1.4) to determine valve pressure drop without choking (valve inlet pressure minus valve outlet pressure).
- Set the ‘available pressure drop’ across the valve equal to the smaller of the two pressure drops from above.
- Determine the required C_v based on the volumetric flow rate, the entering fluid specific gravity, and the available pressure drop.
- Compare the required C_v to the VWO C_v .

H3.1.1 *Valve Inlet Pressure*

The inlet pressure to the control valve is calculated based on the upstream heater shell side pressure. Elevation head between the operating level in the heater and the centerline elevation of the valve is then added/subtracted from this pressure. Next, the pressure drop through the drain cooler or upstream FWH is subtracted, if applicable. Pressure loss in the piping between the upstream heater and the valve is computed using Crane [Ref. H6.2]. These pressure differentials are based on generic plant input.

Attachment H
Heater Drain System Assessment – 30% Thermal Extraction

H3.1.2 Allowable Pressure Drop

The allowable pressure drop is based on the choked pressure drop of the valve and is defined as follows [Ref. H6.1]:

$$\Delta P_{ch} = F_L^2 (P_1 - F_F P_V) \quad \text{Eq. H3-1}$$

where:

ΔP_{ch}	Pressure differential at which the flow chokes [psid]
F_L	Pressure recovery factor (see Assumption H4.1)
P_1	Valve inlet pressure [psia]
F_F	Critical pressure ratio factor (see Equation H3-3)
P_V	Vapor pressure of water at inlet temperature [psia]

and

$$F_F = 0.96 - 0.28 \sqrt{P_V / P_C} \quad \text{Eq. H3-2}$$

where:

F_F	Critical pressure ratio
P_V	Valve inlet vapor pressure [psia]
P_C	Critical pressure of water, 3206 psia [Ref. H6.1]

H3.1.3 Pressure Drop Based on Friction Flow in the Downstream Piping

In addition to the allowable pressure drop based on the valve characteristics, there is also an available pressure drop across the valve based on frictional pressure drop and elevation changes in the downstream piping. These pressure differentials are based on generic plant input. The resulting outlet pressure is then subtracted from the inlet pressure (see Section H3.1.2), giving an available pressure drop across the valve.

H3.1.4 Control Valve Liquid Flow Coefficient C_V

Control valve C_V is defined as [Ref. H6.1]:

$$C_V = \frac{q}{F_P \sqrt{\Delta P_a}} \sqrt{\frac{G_F}{\Delta P_a}} \quad \text{Eq. H3-3}$$

where:

C_V	Valve flow sizing coefficient
q	Flow rate [gpm]
F_P	Piping geometry factor
ΔP_a	Allowable pressure drop across the valve [psid]
G_f	Specific gravity of fluid

Attachment H
Heater Drain System Assessment – 30% Thermal Extraction

In the expression above, q and G_f are based on the entering fluid volumetric flow rate, pressure and temperature. The pressure drop is taken as the minimum of (i) the allowable pressure drop based on choked flow considerations and of (ii) the available pressure drop from frictional and elevation head pressure drop evaluations. Pipe fittings are accounted for in the generic pipe plant losses so the piping geometry factor is not used.

H3.2 Tank Parameters

Operating parameters of the system tanks are reviewed to evaluate the impact of operating with thermal power extraction.

H4.0 ASSUMPTIONS

H4.1 Valve Pressure Recovery Factor (F_L)

A generic pressure recovery factor of $F_L = 0.85$ is used based on typical industry values.

H5.0 DESIGN INPUTS

H5.1 FWH Drain Baseline and 30% Thermal Extraction Conditions

Drain flows, pressures, and temperatures are taken from Attachment A and averaged across the available strings. The average values for the baseline and 30% Thermal Extraction cases are presented in Table H5-1 below.

Table H5-1 – Average FWH Drain Conditions

Parameter	Units	Baseline (0% Thermal Extraction)	30% Thermal Extraction
MSDT Drain Flow	lbm/hr	331,167	192,757
MSDT Drain Pressure	psia	184.6	136.0
MSDT Drain Temperature	°F	375.1	350.8
RH1DT Drain Flow	lbm/hr	135,811	90,676
RH1DT Drain Pressure	psia	444.2	332.0
RH1DT Drain Temperature	°F	455.0	426.7
RH2DT Drain Flow	lbm/hr	200,488	192,645
RH2DT Drain Pressure	psia	864.2	866.1
RH2DT Drain Temperature	°F	527.2	527.4
FWH 3 LPT to Pressure	psia	40.6	28.2
FWH 4 LPT to Flow	lbm/hr	202,252	197,100
FWH 4 LPT to Pressure	psia	89.5	64.5
FWH 1 Extraction Pressure	psia	5.42	3.63
FWH 1 Drain Temp	°F	165.2	148.4
FWH 2 Extraction Pressure	psia	15.9	10.8
FWH 2 Drain Temp	°F	169.9	152.0
FWH 3 Extraction Pressure	psia	40.6	28.2

Attachment H
Heater Drain System Assessment – 30% Thermal Extraction

Parameter	Units	Baseline (0% Thermal Extraction)	30% Thermal Extraction
FWH 3 Drain Temp	°F	225.4	204.6
FWH 4 Extraction Pressure	psia	89.5	64.5
FWH 4 Drain Temp	°F	275.5	253.2
FWH 5 Extraction Pressure	psia	186.1	137.1
FWH 5 Drain Temp	°F	375.8	351.4
FWH 6 Extraction Pressure	psia	287.1	212.7
FWH 6 Drain Temp	°F	374.9	349.3
FWH 7 Extraction Pressure	psia	408.7	303.0
FWH 7 Drain Temp	°F	421.0	393.1
FWH 7 Drain Flow	lbm/hr	658,822	582,489
FWH 6 Drain Flow	lbm/hr	1,059,170	930,613
DC 5 Drain Flow	lbm/hr	1,704,062	1,485,669
FWH 4 Drain Flow	lbm/hr	202,252	197,100
FWH 3 Drain Flow	lbm/hr	398,540	389,159
FWH 2 Drain Flow	lbm/hr	601,704	572,709
DC 1 Drain Flow	lbm/hr	821,877	749,629
Condenser Shell Pressure	psia	1.42	1.10

H6.0 REFERENCES

- H6.1 BHMN-Valve-Sizing-Handbook-TS-19540C-0222, "Masoneilan Control Valve Sizing Handbook," Baker Hughes, 02/2022
- H6.2 Flow of Fluids Through Valve, Fittings, and Pipe, Crane Technical Paper No. 410, 1991
- H6.3 STMFUNC, "Steam Table Function Dynamic Link Library," S&L Program Number 03.7.598-2.0

Attachment H
Heater Drain System Assessment – 30% Thermal Extraction

H7.0 EVALUATIONS**H7.1 Valve Flow Capacity****H7.1.1 *Valve Flow***

Valve volumetric flow is computed based on the mass flow rate and fluid temperature. The liquid density is computed using Excel add-on STMFUNC [Ref. H6.3]. Table H7-1 provides a comparison of the volumetric mass flow rates.

Table H7-1 – Drain Volumetric Flow Comparison

Description	Baseline (0% Extraction) [gpm]	30% Extraction [gpm]	Percent Change [-]
Flash Tank Normal	1,683	1,527	-9.3%
FWH 2 Normal	1,234	1,168	-5.4%
FWH 3 Normal	836	809	-3.2%
FWH 4 Normal	434	419	-3.6%
FWH 6 Normal	2,416	2,086	-13.7%
FWH 7 Normal	1,557	1,346	-13.5%
MSDT Normal	756	433	-42.8%
RHDT1 Normal	331	215	-34.9%
RHDT2 Normal	527	507	-3.9%
Flash Tank Emergency	1,683	1,527	-9.3%
FWH 2 Emergency	1,234	1,168	-5.4%
FWH 3 Emergency	836	809	-3.2%
FWH 4 Emergency	434	419	-3.6%
FWH 5 Emergency	3,890	3,335	-14.3%
FWH 6 Emergency	2,416	2,086	-13.7%
FWH 7 Emergency	1,557	1,346	-13.5%
MSDT Emergency	756	433	-42.8%
RHDT1 Emergency	331	215	-34.9%
RHDT2 Emergency	527	507	-3.9%

As shown in Table H7-1, drain flows decrease between 3% and ~40% when 30% thermal power is extracted.

H7.1.2 *Valve Pressure Drop*

The pressure drop across the valve is the minimum of the allowable pressure drop due to choked flow (see Section H3.1.2) and the available pressure drop from valve inlet to outlet based on flow conditions and frictional losses (see Section H3.1.3). Table H7-2 provides the computed pressure losses. The minimum pressure loss for each valve is shown in bold text.

Attachment H

Heater Drain System Assessment – 30% Thermal Extraction

Table H7-2 – Drain Valve Pressure Loss

Description	Baseline (0% Extraction)		30% Extraction		Percent Change	
	Choked dP [psid]	Available dP [psid]	Choked dP [psid]	Available dP [psid]	Choked dP [-]	Available dP [-]
Flash Tank Normal	2.7	7.3	2.9	6.2	8.0%	-14.6%
FWH 2 Normal	2.3	3.2	0.5	0.5	-77.6%	-83.4%
FWH 3 Normal	9.1	14.6	4.7	7.6	-48.7%	-48.0%
FWH 4 Normal	32.1	44.5	23.5	32.2	-26.5%	-27.6%
FWH 6 Normal	85.0	95.9	63.3	70.8	-25.5%	-26.2%
FWH 7 Normal	90.9	108.1	65.3	76.9	-28.1%	-28.8%
MSDT Normal	19.6	5.9	15.1	6.5	-23.0%	11.0%
RHDT1 Normal	42.7	249.3	28.1	187.3	-34.0%	-24.9%
RHDT2 Normal	115.6	454.6	116.0	562.4	0.4%	23.7%
Flash Tank Emergency	4.1	9.2	4.1	7.8	-0.7%	-15.1%
FWH 2 Emergency	5.5	11.7	3.7	7.6	-32.5%	-35.0%
FWH 3 Emergency	15.0	37.1	10.6	25.4	-29.1%	-31.4%
FWH 4 Emergency	38.4	92.0	30.0	67.8	-21.9%	-26.3%
FWH 5 Emergency	23.0	196.4	18.5	148.1	-19.4%	-24.6%
FWH 6 Emergency	86.9	283.3	65.3	209.6	-24.9%	-26.0%
FWH 7 Emergency	97.5	405.9	72.0	300.9	-26.1%	-25.9%
MSDT Emergency	16.4	186.0	11.8	137.9	-28.2%	-25.9%
RHDT1 Emergency	47.6	444.7	32.9	333.2	-30.9%	-25.1%
RHDT2 Emergency	116.8	862.6	117.3	865.2	0.4%	0.3%

As shown in Table H7-2, all drain control valves experience choked flow conditions except the moisture separator drain tank. With respect to valve capacity, a decrease in valve pressure loss is non-conservative, as the pressure loss is in the denominator (see Equation H3-3). Therefore, nearly all valves see a non-conservative reduction in allowable pressure loss, with the exception of the 2nd stage reheater drain tank. In most cases, the reduction in allowable pressure drop is significant, with FWH 2 normal drains seeing greater than 80% reduction in available dP. The resulting impact on required C_v is discussed in Section H7.3.

H7.1.3 Required Valve C_v

The resulting required valve C_v values are presented in Table H7-3.

Table H7-3 – Drain Valve Required C_v Capacity

Description	Baseline (0% Extraction) [-]	30% Extraction [-]	Percent Change [-]
Flash Tank Normal	1019	892	-12.5%
FWH 2 Normal	796	1595	100.5%

Attachment H
Heater Drain System Assessment – 30% Thermal Extraction

Description	Baseline (0% Extraction) [-]	30% Extraction [-]	Percent Change [-]
FWH 3 Normal	271	367	35.8%
FWH 4 Normal	74	84	13.1%
FWH 6 Normal	245	248	0.9%
FWH 7 Normal	150	155	3.2%
MSDT Normal	292	160	-45.2%
RHDT1 Normal	46	37	-18.8%
RHDT2 Normal	43	41	-4.1%
Flash Tank Emergency	823	751	-8.7%
FWH 2 Emergency	520	600	15.5%
FWH 3 Emergency	211	243	15.4%
FWH 4 Emergency	68	74	9.7%
FWH 5 Emergency	759	731	-3.7%
FWH 6 Emergency	243	244	0.5%
FWH 7 Emergency	145	147	1.7%
MSDT Emergency	175	119	-31.9%
RHDT1 Emergency	43	34	-20.7%
RHDT2 Emergency	43	41	-4.1%

As shown in Table H7-3, the required C_v capacity for all FWHs increases with 30% thermal power extraction. Flash tank and the various MSR drain tanks all see reduced capacity requirements. FWHs 4, 6, and 7 exhibit required increases of less than 15%, which is typically within the operating margin of a well sized drain control valve. Therefore, no equipment changes would be expected, but a station specific review is required. FWHs 2 and 3, on the other hand, show significant increase in required flow capacity, with FWH 2 requiring approximately double the baseline capacity. Therefore, it is expected that a station specific review of these FWHs would result in requiring valve replacement prior to operation with thermal power extracted.

H7.2 Drain Tank Parameters

The operating parameters for the drain tanks (MSDT, RH1DT, RH2DT, & Flash Tank) are reviewed in Table H7-4.

Table H7-4 – Drain Tank Conditions

Parameter	Units	Baseline (0% Extraction)	30% Extraction	Change
MSDT Drain Flow	<i>lbm/hr</i>	331,167	192,757	-41.8%
RH1DT Drain Flow	<i>lbm/hr</i>	135,811	90,676	-33.2%
RH2DT Drain Flow	<i>lbm/hr</i>	200,488	192,645	-3.9%
Flash Tank Drain Flow	<i>lbm/hr</i>	821,877	749,629	-8.8%
MSDT Drain Pressure	<i>psia</i>	184.6	136.0	-26.3%

Attachment H
Heater Drain System Assessment – 30% Thermal Extraction

Parameter	Units	Baseline (0% Extraction)	30% Extraction	Change
RH1DT Drain Pressure	<i>psia</i>	444.2	332.0	-25.3%
RH2DT Drain Pressure	<i>psia</i>	864.2	866.1	0.2%
Flash Tank Drain Pressure	<i>psia</i>	5.42	3.63	-33.0%
MSDT Drain Temperature	<i>°F</i>	375.1	350.8	-24.3°F
RH1DT Drain Temperature	<i>°F</i>	455.0	426.7	-28.3°F
RH2DT Drain Temperature	<i>°F</i>	527.2	527.4	0.3°F
Flash Tank Drain Temperature	<i>°F</i>	165.2	148.4	-16.8°F

As shown in Table H7-4, mass flow rates decrease for all drain tanks. Pressure and temperatures also increase for all tanks except the 2nd stage reheater drain tank. Conditions for RH2DT show minimal change. As all parameters either decrease or show minimal change, the heater drain system drain tanks are expected to operate normally during thermal power extraction operation.

H8.0 RESULTS AND CONCLUSIONS

The required C_v capacity for all the flash tank and the various MSR drain tanks DCVs show reduced capacity requirements when operating with thermal power extraction. DCVs for all FWHs will require greater flow passing capability. FWHs 4, 6, and 7 exhibit required increases of less than 15%, which is typically within the operating margin of a well sized drain control valve. Therefore, no equipment changes would be expected, but a station specific review is required. FWHs 2 and 3, on the other hand, show significant increase in required flow capacity, with FWH 2 requiring approximately double the baseline capacity. Therefore, it is expected that a station specific review of these FWHs would result in requiring valve replacement prior to operation with thermal power extracted for FWHs 2 and 3.

Operating parameters for all heater drain system drain tanks either decrease or show minimal change and are expected to operate normally during thermal power extraction operation.

Attachment I – HP and LP Turbine Assessment with 50% Thermal Energy Extracted

Prepared: Henry Fidlow

Reviewed: Nic Richards

Attachment I
HP and LP Turbine Assessment – 50% Thermal Extraction

11.0 PURPOSE

The purpose of this appendix is to assess the turbine performance and expected changes to operating conditions due to operation with 50% turbine cycle thermal energy extracted from the main steam. This evaluation is performed for two scenarios: (1) 50% thermal energy extracted from main steam, and (2) 50% thermal energy extracted from main steam with 20% condensate flow bypass around the low-pressure feedwater heaters.

12.0 SYSTEM & COMPONENT DESCRIPTION

A representative turbine cycle is chosen to evaluate the impact of energy extraction. A PWR unit with a single High Pressure Turbine (HPT) and three parallel Low Pressure Turbines (LPTs) is used. The representative cycle contains a Moisture Separator Reheater (MSR) between the HPT and LPTS, where moisture is removed from the HPT exhaust and heated with two stages of regenerative heating. The turbines provide extraction to seven feedwater heater stages.

The representative turbine cycle performance is modeled in a PEPSE™ model which contains cases benchmarked to the turbine vendor's thermal kit. Cases at Valves Wide Open (VWO), rated thermal power (100%), and 50% power are provided.

For the case with 50% turbine cycle thermal energy extracted, the PEPSE heat balance was modified as documented in Attachment A. The modification included removal of steam from the main steam system and return of the condensate to the main condenser after the energy was extracted.

13.0 METHODOLOGY**13.1 Enthalpy-Entropy Chart**

Turbine performance modeled by PEPSE is visually represented on an Enthalpy-Entropy Chart. Turbine interstage pressures and enthalpies are taken from the PEPSE model for the Rated Load and 50% Load cases (see Input I5.1) to determine design turbine performance. The entropy of each condition is computed using Excel add-on STMFUNC, and plotted against the corresponding enthalpy. The same properties are extracted from the PEPSE model for the baseline scenario (0% thermal extraction) and 50% turbine cycle thermal energy extracted and plotted for comparison to the design turbine performance.

13.2 Flow Comparison

The interstage mass flow rates from the baseline scenario and 50% turbine cycle thermal energy extracted case are compared. Any increases in flows are noted. Also, as the HPT is not symmetrical (FWH7 and 2nd Stage Reheat (RH2) extractions are taken from the right side and FWH6 extraction from the left), flow rates are reviewed for any potential imbalance between the two sides created when operating with 50% turbine cycle thermal energy extracted.

14.0 ASSUMPTIONS

None

Attachment I
HP and LP Turbine Assessment – 50% Thermal Extraction

15.0 DESIGN INPUTS**15.1 Turbine Design Conditions at Rated and 50% Load**

Turbine flows, pressures, and enthalpies are taken from the PEPSE model for the rated and 50% Load design case and presented in Table I5-1 below.

Table I5-1 – Turbine Design Values (from PEPSE™)

Location	Rated Load			50% Load		
	Mass Flow [lbm/hr]	Pressure [psia]	Enthalpy [BTU/lbm]	Mass Flow [lbm/hr]	Pressure [psia]	Enthalpy [BTU/lbm]
Throttle Valve Inlet	15,606,360	882.0	1,195	6,773,168	999.3	1,191
HPT Bowl (Left)	7,803,179	834.6	1,195	3,386,584	362.5	1,191
Governing Stage Shell (Left)	7,803,179	666.4	1,179	3,386,584	293.4	1,198
FWH6 Extraction Stage (Left)	6,976,506	302.7	1,128	3,142,344	144.2	1,157
HPT Exhaust (Left)	6,976,506	192.1	1,099	3,142,344	96.6	1,129
HPT Bowl (Right)	7,803,179	834.6	1,195	3,386,584	362.5	1,191
Governing Stage Shell (Right)	7,803,179	666.4	1,178	3,386,584	294.1	1,198
FWH7 + RH2 Extraction Stage (Right)	6,517,590	447.4	1,154	3,114,517	214.5	1,180
HPT Exhaust (Right)	6,517,590	192.1	1,099	3,114,517	96.6	1,130
LPT A Bowl	3,675,072	175.3	1,273	1,812,948	88.1	1,289
FWH4A Extraction Stage	3,471,365	92.2	1,218	1,729,224	46.8	1,233
FWH3A Extraction Stage	3,277,938	41.9	1,158	1,647,395	21.2	1,171
FWH2A Extraction Stage	3,075,305	16.4	1,105	1,565,210	8.3	1,115
MR (to FWH1A) Extraction Stage	3,015,678	10.2	1,088	1,540,147	5.2	1,095
FWH1A Extraction Stage	2,869,644	5.62	1,068	1,515,631	2.93	1,076
MR (to LPT A Exhaust) Extraction Stage	2,801,781	3.44	1,057	1,486,296	2.11	1,068
LPT A Exhaust	2,801,781	1.72	1,026	1,486,296	1.72	1,059
LPT B Bowl	3,675,072	175.5	1,273	1,812,948	88.2	1,289
FWH4B Extraction Stage	3,471,369	92.2	1,218	1,729,219	46.8	1,233

Attachment I
HP and LP Turbine Assessment – 50% Thermal Extraction

Location	Rated Load			50% Load		
	Mass Flow [lbm/hr]	Pressure [psia]	Enthalpy [BTU/lbm]	Mass Flow [lbm/hr]	Pressure [psia]	Enthalpy [BTU/lbm]
FWH3B Extraction Stage	3,277,928	41.9	1,158	1,647,392	21.2	1,171
FWH2B Extraction Stage	3,075,253	16.4	1,105	1,565,185	8.3	1,115
MR (to FWH1B) Extraction Stage	3,015,598	10.2	1,088	1,540,107	5.2	1,095
FWH1B Extraction Stage	2,869,548	5.62	1,068	1,515,582	2.93	1,076
MR (to LPT B Exhaust) Extraction Stage	2,801,669	3.44	1,057	1,486,239	2.11	1,068
LPT B Exhaust	2,801,669	1.72	1,026	1,486,239	1.72	1,059
LPT C Bowl	3,675,072	175.5	1,273	1,812,948	88.2	1,289
FWH4C Extraction Stage	3,471,370	92.2	1,218	1,729,219	46.8	1,233
FWH3C Extraction Stage	3,277,928	41.9	1,158	1,647,392	21.2	1,171
FWH2C Extraction Stage	3,075,259	16.4	1,105	1,565,182	8.3	1,115
MR (to FWH1C) Extraction Stage	3,015,604	10.2	1,088	1,540,104	5.2	1,095
FWH1C Extraction Stage	2,869,642	5.62	1,068	1,515,533	2.93	1,076
MR (to LPT C Exhaust) Extraction Stage	2,801,762	3.44	1,057	1,486,191	2.11	1,068
LPT C Exhaust	2,801,762	1.72	1,026	1,486,191	1.72	1,059

Attachment I
HP and LP Turbine Assessment – 50% Thermal Extraction

15.2 Turbine Baseline and 50% Thermal Extraction Conditions

Turbine flows, pressures, and enthalpies are taken from the PEPSE model for the baseline and 50% Thermal Extraction cases and presented in Tables 15-2 and 15-3 below.

Table 15-2 – Turbine Performance Values (from PEPSE™) for 50% Thermal Extraction

Location	Baseline (0% Thermal Extraction)			50% Thermal Extraction		
	Mass Flow [lbm/hr]	Pressure [psia]	Enthalpy [BTU/lbm]	Mass Flow [lbm/hr]	Pressure [psia]	Enthalpy [BTU/lbm]
Throttle Valve Inlet	15,218,400	870.3	1,197	8,615,524	870.3	1,197
HPT Bowl (Left)	7,609,201	801.5	1,197	4,307,762	408.5	1,197
Governing Stage Shell (Left)	7,609,201	651.5	1,182	4,307,762	374.8	1,203
FWH6 Extraction Stage (Left)	6,808,507	296.5	1,132	3,673,657	166.6	1,154
HPT Exhaust (Left)	6,808,507	192.2	1,104	3,673,657	105.6	1,123
HPT Bowl (Right)	7,609,201	801.5	1,197	4,307,762	408.5	1,197
Governing Stage Shell (Right)	7,609,201	651.6	1,182	4,307,762	375.5	1,203
FWH7 + RH2 Extraction Stage (Right)	6,550,264	451.0	1,159	3,736,225	258.4	1,181
HPT Exhaust (Right)	6,550,264	192.2	1,104	3,736,225	105.6	1,124
LPT A Bowl	3,673,069	175.5	1,274	1,980,267	96.4	1,290
FWH4A Extraction Stage	3,470,241	92.3	1,219	1,789,735	48.2	1,229
FWH3A Extraction Stage	3,271,723	41.8	1,159	1,600,058	20.3	1,163
FWH2A Extraction Stage	3,075,061	16.4	1,106	1,443,447	7.6	1,107
MR (to FWH1A) Extraction Stage	3,015,812	10.2	1,088	1,418,517	4.7	1,089
FWH1A Extraction Stage	2,855,450	5.60	1,068	1,309,843	2.52	1,068
MR (to LPT A Exhaust) Extraction Stage	2,788,284	3.43	1,057	1,283,649	1.84	1,062
LPT A Exhaust	2,788,284	1.24	1,022	1,283,649	0.87	1,030
LPT B Bowl	3,673,069	175.7	1,274	1,980,267	96.5	1,290
FWH4B Extraction Stage	3,468,763	92.3	1,219	1,788,450	48.2	1,229
FWH3B Extraction Stage	3,273,638	41.8	1,159	1,600,396	20.3	1,163

Attachment I
HP and LP Turbine Assessment – 50% Thermal Extraction

Location	Baseline (0% Thermal Extraction)			50% Thermal Extraction		
	Mass Flow [lbm/hr]	Pressure [psia]	Enthalpy [BTU/lbm]	Mass Flow [lbm/hr]	Pressure [psia]	Enthalpy [BTU/lbm]
FWH2B Extraction Stage	3,068,421	16.4	1,106	1,437,431	7.5	1,106
MR (to FWH1B) Extraction Stage	3,008,809	10.2	1,088	1,413,529	4.7	1,087
FWH1B Extraction Stage	2,847,364	5.58	1,068	1,303,364	2.50	1,066
MR (to LPT B Exhaust) Extraction Stage	2,780,228	3.42	1,057	1,276,719	1.83	1,061
LPT B Exhaust	2,780,228	1.38	1,023	1,276,719	0.90	1,030
LPT C Bowl	3,673,069	175.7	1,274	1,980,267	96.5	1,290
FWH4C Extraction Stage	3,473,448	92.4	1,219	1,792,958	48.3	1,230
FWH3C Extraction Stage	3,278,225	41.9	1,159	1,604,687	20.4	1,163
FWH2C Extraction Stage	3,070,612	16.4	1,106	1,438,541	7.6	1,107
MR (to FWH1C) Extraction Stage	3,011,389	10.2	1,088	1,413,650	4.7	1,088
FWH1C Extraction Stage	2,850,762	5.59	1,068	1,304,880	2.51	1,068
MR (to LPT C Exhaust) Extraction Stage	2,783,458	3.42	1,057	1,278,498	1.84	1,062
LPT C Exhaust	2,783,458	1.64	1,028	1,278,498	0.99	1,035

Attachment I
HP and LP Turbine Assessment – 50% Thermal Extraction

Table I5-3 – Turbine Performance Values (from PEPSE™) for 50% Thermal Extraction with Bypass

Location	Baseline (0% Thermal Extraction)			50% Thermal Extraction w/ Bypass		
	Mass Flow [lbm/hr]	Pressure [psia]	Enthalpy [BTU/lbm]	Mass Flow [lbm/hr]	Pressure [psia]	Enthalpy [BTU/lbm]
Throttle Valve Inlet	15,218,400	870.3	1,197	8,619,505	870.3	1,197
HPT Bowl (Left)	7,609,201	801.5	1,197	4,309,753	408.7	1,197
Governing Stage Shell (Left)	7,609,201	651.5	1,182	4,309,753	375.2	1,204
FWH6 Extraction Stage (Left)	6,808,507	296.5	1,132	3,589,053	162.7	1,154
HPT Exhaust (Left)	6,808,507	192.2	1,104	3,589,053	98.6	1,118
HPT Bowl (Right)	7,609,201	801.5	1,197	4,309,753	408.7	1,197
Governing Stage Shell (Right)	7,609,201	651.6	1,182	4,309,753	375.9	1,204
FWH7 + RH2 Extraction Stage (Right)	6,550,264	451.0	1,159	3,722,015	257.5	1,181
HPT Exhaust (Right)	6,550,264	192.2	1,104	3,722,015	98.6	1,120
LPT A Bowl	3,673,069	175.5	1,274	1,845,837	90.0	1,292
FWH4A Extraction Stage	3,470,241	92.3	1,219	1,704,350	46.1	1,233
FWH3A Extraction Stage	3,271,723	41.8	1,159	1,562,271	20.0	1,167
FWH2A Extraction Stage	3,075,061	16.4	1,106	1,436,663	7.6	1,111
MR (to FWH1A) Extraction Stage	3,015,812	10.2	1,088	1,412,978	4.7	1,092
FWH1A Extraction Stage	2,855,450	5.60	1,068	1,323,666	2.55	1,071
MR (to LPT A Exhaust) Extraction Stage	2,788,284	3.43	1,057	1,297,881	1.87	1,064
LPT A Exhaust	2,788,284	1.24	1,022	1,297,881	0.87	1,032
LPT B Bowl	3,673,069	175.7	1,274	1,845,837	90.1	1,292
FWH4B Extraction Stage	3,468,763	92.3	1,219	1,703,682	46.1	1,233
FWH3B Extraction Stage	3,273,638	41.8	1,159	1,563,189	20.0	1,167
FWH2B Extraction Stage	3,068,421	16.4	1,106	1,434,512	7.6	1,110
MR (to FWH1B) Extraction Stage	3,008,809	10.2	1,088	1,411,741	4.7	1,090

Attachment I
HP and LP Turbine Assessment – 50% Thermal Extraction

Location	Baseline (0% Thermal Extraction)			50% Thermal Extraction w/ Bypass		
	Mass Flow [lbm/hr]	Pressure [psia]	Enthalpy [BTU/lbm]	Mass Flow [lbm/hr]	Pressure [psia]	Enthalpy [BTU/lbm]
FWH1B Extraction Stage	2,847,364	5.58	1,068	1,321,198	2.54	1,070
MR (to LPT B Exhaust) Extraction Stage	2,780,228	3.42	1,057	1,294,929	1.86	1,063
LPT B Exhaust	2,780,228	1.38	1,023	1,294,929	0.90	1,033
LPT C Bowl	3,673,069	175.7	1,274	1,845,837	90.1	1,292
FWH4C Extraction Stage	3,473,448	92.4	1,219	1,706,039	46.2	1,233
FWH3C Extraction Stage	3,278,225	41.9	1,159	1,565,294	20.0	1,167
FWH2C Extraction Stage	3,070,612	16.4	1,106	1,434,238	7.5	1,111
MR (to FWH1C) Extraction Stage	3,011,389	10.2	1,088	1,410,563	4.7	1,092
FWH1C Extraction Stage	2,850,762	5.59	1,068	1,320,862	2.54	1,071
MR (to LPT C Exhaust) Extraction Stage	2,783,458	3.42	1,057	1,294,859	1.86	1,064
LPT C Exhaust	2,783,458	1.64	1,028	1,294,859	1.00	1,037

16.0 REFERENCES

- 16.1 Computer Code PEPSE™ (Performance Evaluation of Power System Efficiencies), Version 84.1 by Scientech Incorporated, S&L Program No. 03.7.551-84.0, Controlled File Path: C:\Program Files (x86)\Applist\PEP55184\
- 16.2 STMFUNC, "Steam Table Function Dynamic Link Library," S&L Program Number 03.7.598-2.0

Attachment I
 HP and LP Turbine Assessment – 50% Thermal Extraction

17.0 EVALUATIONS

17.1 H-S Diagram

Turbine performance can be visualized by plotting on an enthalpy-entropy chart (H-S). Figures I7-1 and I7-2 plot the design turbine performance at 100% and 50% thermal power along with the baseline and 50% extraction cases (with and without bypass).

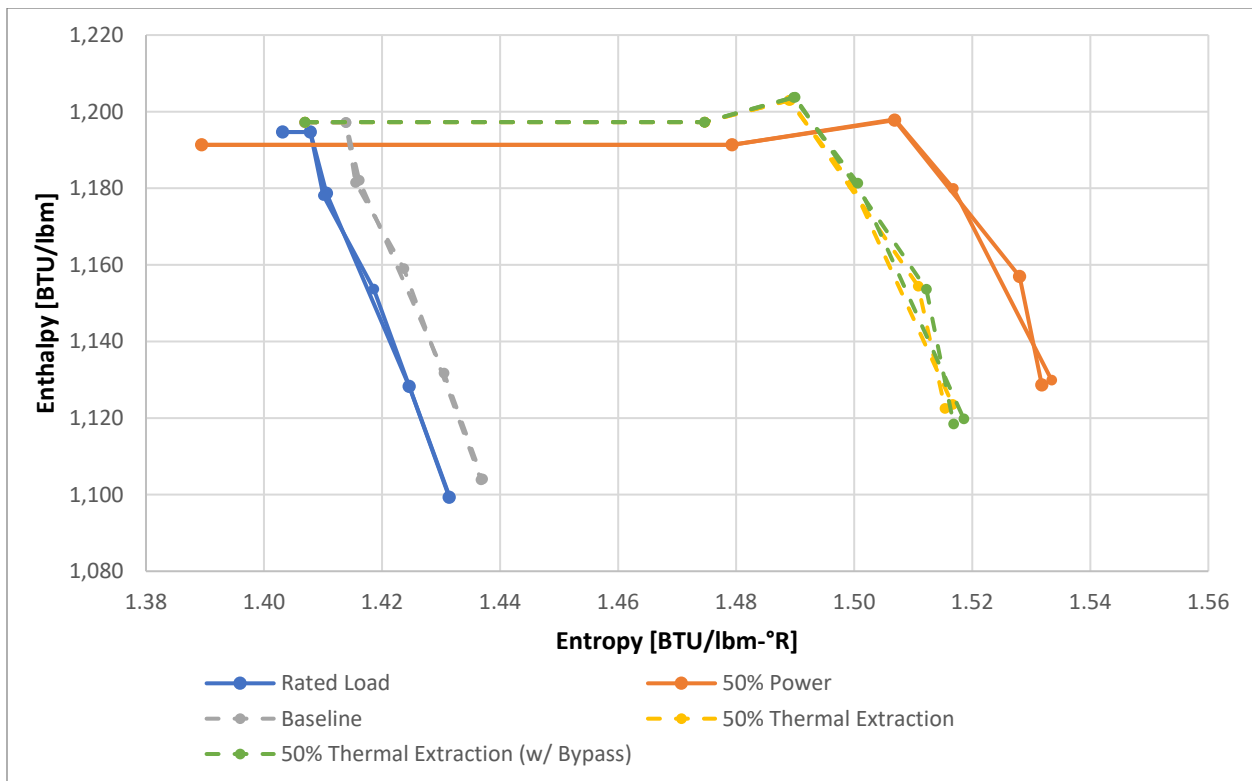

Figure I7-1: Enthalpy-Entropy Chart (HPT)

Attachment I
 HP and LP Turbine Assessment – 50% Thermal Extraction

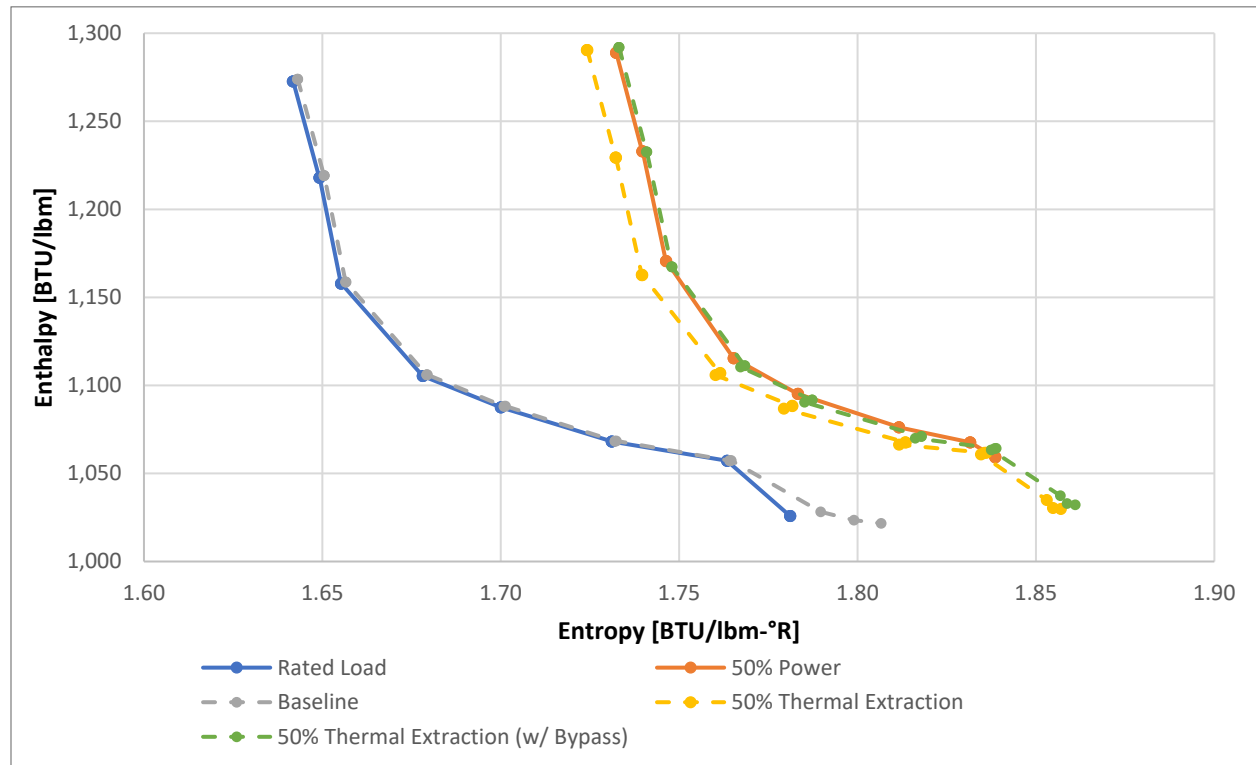

Figure I7-2: Enthalpy-Entropy Chart (LPT)

As shown in Figures I7-1 and I7-2, the Baseline turbine performance trends very closely to the Rated Load case. Similarly, the 50% Extraction turbine performance trends closely to the 50% Power case. In Figure I7-1, values for the left and right sides of the HPT are shown separately. Based on the behavior shown, performance between the two sides is nearly identical.

I7.2 Flow Comparison

Table I7-1 provides a comparison of the mass flow rates from baseline scenario to the 50% power extraction scenarios (with and without bypass).

Table I7-1 – Mass Flow Comparison

Location	Baseline [lbm/hr]	50% Thermal Extraction		50% Thermal Extraction w/ Bypass	
		Mass Flow [lbm/hr]	Percent Change [-]	Mass Flow [lbm/hr]	Percent Change [-]
Throttle Valve Inlet	15,218,400	8,615,524	-43%	8,619,505	-43%
HPT Bowl (Left)	7,609,201	4,307,762	-43%	4,309,753	-43%
Governing Stage Shell (Left)	7,609,201	4,307,762	-43%	4,309,753	-43%
FWH6 Extraction Stage (Left)	6,808,507	3,673,657	-46%	3,589,053	-47%
HPT Exhaust (Left)	6,808,507	3,673,657	-46%	3,589,053	-47%

Attachment I
HP and LP Turbine Assessment – 50% Thermal Extraction

Location	Baseline [lbm/hr]	50% Thermal Extraction		50% Thermal Extraction w/ Bypass	
		Mass Flow [lbm/hr]	Percent Change [-]	Mass Flow [lbm/hr]	Percent Change [-]
HPT Bowl (Right)	7,609,201	4,307,762	-43%	4,309,753	-43%
Governing Stage Shell (Right)	7,609,201	4,307,762	-43%	4,309,753	-43%
FWH7 + RH2 Extraction Stage (Right)	6,550,264	3,736,225	-43%	3,722,015	-43%
HPT Exhaust (Right)	6,550,264	3,736,225	-43%	3,722,015	-43%
LPT A Bowl	3,673,069	1,980,267	-46%	1,845,837	-50%
FWH4A Extraction Stage	3,470,241	1,789,735	-48%	1,704,350	-51%
FWH3A Extraction Stage	3,271,723	1,600,058	-51%	1,562,271	-52%
FWH2A Extraction Stage	3,075,061	1,443,447	-53%	1,436,663	-53%
MR (to FWH1A) Extraction Stage	3,015,812	1,418,517	-53%	1,412,978	-53%
FWH1A Extraction Stage	2,855,450	1,309,843	-54%	1,323,666	-54%
MR (to LPT A Exhaust) Extraction Stage	2,788,284	1,283,649	-54%	1,297,881	-53%
LPT A Exhaust	2,788,284	1,283,649	-54%	1,297,881	-53%
LPT B Bowl	3,673,069	1,980,267	-46%	1,845,837	-50%
FWH4B Extraction Stage	3,468,763	1,788,450	-48%	1,703,682	-51%
FWH3B Extraction Stage	3,273,638	1,600,396	-51%	1,563,189	-52%
FWH2B Extraction Stage	3,068,421	1,437,431	-53%	1,434,512	-53%
MR (to FWH1B) Extraction Stage	3,008,809	1,413,529	-53%	1,411,741	-53%
FWH1B Extraction Stage	2,847,364	1,303,364	-54%	1,321,198	-54%
MR (to LPT B Exhaust) Extraction Stage	2,780,228	1,276,719	-54%	1,294,929	-53%
LPT B Exhaust	2,780,228	1,276,719	-54%	1,294,929	-53%
LPT C Bowl	3,673,069	1,980,267	-46%	1,845,837	-50%
FWH4C Extraction Stage	3,473,448	1,792,958	-48%	1,706,039	-51%
FWH3C Extraction Stage	3,278,225	1,604,687	-51%	1,565,294	-52%
FWH2C Extraction Stage	3,070,612	1,438,541	-53%	1,434,238	-53%
MR (to FWH1C) Extraction Stage	3,011,389	1,413,650	-53%	1,410,563	-53%
FWH1C Extraction Stage	2,850,762	1,304,880	-54%	1,320,862	-54%
MR (to LPT C Exhaust) Extraction Stage	2,783,458	1,278,498	-54%	1,294,859	-53%
LPT C Exhaust	2,783,458	1,278,498	-54%	1,294,859	-53%

As shown in Table I7-1, across both 50% thermal extraction scenarios, the turbine experiences a reduction in mass flow rate between ~43% and ~54%. Notably, the HPT interstage flows all decrease by a similar margin (43% - 47%). This is important as the HPT is not symmetric, with FWH7 and 2nd Stage Reheat (RH2) extractions coming off the right side and FWH6 extraction coming from the left. Based on the relatively consistent reduction in flow on either side, additional stress due to imbalanced loading on the turbine is not expected.

Attachment I
HP and LP Turbine Assessment – 50% Thermal Extraction

18.0 RESULTS AND CONCLUSIONS

A review of the turbine performance modeled in PEPSE for baseline and 50% thermal energy extraction conditions shows strong alignment with the design turbine performance at rated and 50% thermal power conditions. The turbine is expected to experience a reduction in mass flow rate of approximately 50% when operating with 50% thermal energy extracted for off-site use. HPT flows are expected to reduce by a similar amount on either side of the HPT flow path. Therefore, additional stress due to imbalanced loading on the turbine is not expected. Partial low pressure feedwater heater bypass does not negatively impact turbine performance.

Based on the review of the PEPSE heat balance conditions, the turbine is expected to operate within design for operation with up to 50% thermal energy extracted with and without partial low-pressure feedwater heater bypass. However, final acceptability of operation under this condition must be confirmed with the turbine vendor on a plant specific basis.

The turbine control system is expected to require changes to accommodate operation with thermal energy extracted for off-site use. The evaluation of, and potential changes to, turbine controls needs to be performed separately and is not within the scope of this assessment.

Attachment J – Condenser Evaluation with 50% Thermal Energy Extracted

Prepared: Henry Fidlow

Reviewed: Nic Richards

J1.0 PURPOSE

The purpose of this evaluation is to examine required duty and expected changes to operating conditions and performance parameters in relation to the design of the Main Condenser. These changes are due to steam extraction for supplying thermal energy off-site. This evaluation is performed for two scenarios: (1) 50% thermal energy extracted from main steam, and (2) 50% thermal energy extracted from main steam with 20% condensate flow bypass around the low-pressure feedwater heaters.

J2.0 SYSTEM & COMPONENT DESCRIPTION

The main condenser is the steam cycle heat sink. During normal operation it receives and condenses main turbine exhaust steam. Turbine bypass steam is also routed to the main condenser when required. The main condenser is also a collection point for other steam cycle miscellaneous flows, drains, and vents

Although there are three independent zones for steam flow, the condenser has a single pass of Circulating Water (CW). CW enters at the low pressure zone, passes through the intermediate pressure zone and exits at the high pressure zone. The cold surface of the stainless steel tubes condenses the steam into water, which is collected in the hotwell.

The purpose of the main condenser evacuation and off-gas system is to maintain a vacuum in the condenser and to remove noncondensable gas (including air inleakage and other noncondensable gases introduced to the condenser).

For the purpose of this assessment it is assumed that the main steam used for the 50% thermal extraction is condensed and routed back to the main condenser as shown on PEPSE Heat Balance diagrams documented in Attachment A.

J3.0 METHODOLOGY

The operating conditions of the main condenser are evaluated for these 50% thermal extraction scenarios and compared to baseline operation. These operating conditions are taken from the PEPSE Heat Balance results documented in Attachment A. The results of this comparison are used to evaluate the impact on condenser thermal performance and flow-induced tube vibration.

The required air removal capacity is not specifically evaluated as, during power operation, the major sources of noncondensable gases in the main condenser are air leaks in the condenser shell, which is not expected to change for the 50% thermal extraction scenarios.

J4.0 ASSUMPTIONS

- J4.1 Circulating Water Conditions – The PEPSE results presented in Attachment A assume constant Circulating Water (CW) conditions (inlet temperature and flow rate) between the baseline and 50% thermal energy extraction cases. This is assumed for simplicity and is reasonable as thermal energy extraction is not expected to have any impact on CW availability.

Attachment J
Condenser Evaluation – 50% Thermal Extraction

J5.0 DESIGN INPUTS

Operating conditions are taken from the PEPSE Heat Balance results documented in Attachment A and presented in Table J7-1.

J6.0 REFERENCES

None

J7.0 EVALUATIONS

The condenser operating conditions for the baseline and 50% thermal extraction scenarios are compared in Table J7-1.

Table J7-1: Condenser Operating Conditions

Description	Units	0%	50%	Δ (50%)	50% w/ Bypass	Δ (50% w/ Bypass)
Condenser A Shell Pressure	psia	1.24	0.87	-29.6%	0.88	-29.5%
Condenser A Shell Flow	lbm/hr	3,120,435	1,581,734	-49.3%	1,585,830	-49.2%
Condenser A Duty	BTU/hr	2.92E+09	1.57E+09	-46.1%	1.58E+09	-45.9%
Condenser B Shell Pressure	psia	1.38	0.90	-34.9%	0.90	-34.5%
Condenser B Shell Flow	lbm/hr	2850639	1,306,657	-54.2%	1,324,491	-53.5%
Condenser B Duty	BTU/hr	2.64E+09	1.29E+09	-51.1%	1.31E+09	-50.4%
Condenser C Shell Pressure	psia	1.64	0.99	-39.8%	1.00	-39.4%
Condenser C Shell Flow	lbm/hr	2,854,037	1,308,173	-54.2%	1,324,155	-53.6%
Condenser C Duty	BTU/hr	2.65E+09	1.31E+09	-50.5%	1.33E+09	-49.9%
Hotwell Temperature	°F	115.6	98.1	-17.5°F	98.3	-17.3°F
Condensate Flow	lbm/hr	11,334,490	11,889,450	4.90%	11,475,500	1.2%

As shown in Table J7-1, with constant CW conditions, condenser backpressures decrease when thermal energy is extracted, so this scenario will not trigger a high backpressure alarm or exceed the turbine trip setpoint. Any limits on condensate hotwell temperature will not be challenged as this temperature decreases for the thermal extraction case. Decreased steam flow rates will also reduce the severity of flow-induced vibrations. Since the main steam used for the 50% thermal extraction is condensed and routed back to the main condenser there is a small increase in the total condensate flow. Additionally, since the overall condenser duty goes down with thermal energy extraction, the condenser's ability to accept turbine bypass steam is not affected. The 20% bypass around the low pressure FWHS has negligible impact on the condenser compared to no bypass.

J8.0 RESULTS AND CONCLUSIONS

An evaluation of condenser operating conditions shows that the condenser will continue to meet operation requirements for 50% thermal extraction conditions. Condenser steam flow rates, backpressures, and heat loads decrease for the thermal extraction case, so backpressure limits will not be challenged, and the severity of flow-induced vibrations will be reduced. Due to the additional condensate routed back to the main condenser there is a small increase in the total condensate flow. Additionally, since the overall condenser duty goes down with thermal energy extraction, the condenser's ability to accept turbine bypass steam is not affected. Partial low pressure feedwater heater bypass has negligible impact on condenser operation.

The evacuation capacity of the condensers is not affected by operating with 50% thermal extraction conditions.

Attachment K – Power Train Pumps Evaluation with 50% Thermal Energy Extracted

Prepared: Henry Fidlow

Reviewed: Nic Richards

K1.0 PURPOSE

The purpose of this evaluation is to examine the required duty and expected changes to operating conditions and performance parameters in relation to the power train pumps and drivers, consisting of the Condensate Pumps (CDPs), Condensate Booster Pumps (CBPs), Heater Drain Pumps (HDPs), and the Feedwater Pumps (FWPs). Changes to the heater drain tank level control valves are also evaluated. These changes are due to extracting steam from the nuclear power cycle main steam system to supply thermal energy to the plant boundary for off-site use. This evaluation is performed for two scenarios: (1) 50% thermal energy extracted from main steam, and (2) 50% thermal energy extracted from main steam with 20% condensate flow bypass around the low-pressure feedwater heaters.

K2.0 SYSTEM & COMPONENT DESCRIPTION

K2.1 System Description

The power conversion system is a closed cycle, with the CD, CB, and FW systems working to deliver water from the condenser hotwell to the four Steam Generators (S/Gs). The CDPs draw water from the condenser and pump it through the Steam Jet Air Ejector (SJAE) condensers and gland steam condensers (GSCs) to the CBPs. The booster pumps provide the required head to pump the condensate through the Low Pressure (LP) FW heaters and to provide sufficient suction head at the two Turbine Driven Feed Pumps (TDFPs). The water collected from the heater drains is stored in the Heater Drain Tank (HDT) and is forwarded into the CB system upstream of the 5th point heaters through the HDPs. In the FW system, the water is pumped through one stage of High Pressure (HP) FW heaters and then on to four S/Gs.

K2.2 Pump Description

The suction energy level of each pump is given in Table K2-1. This is used in determining the Preferred Operating Region and minimum NPSH ratio acceptance criteria for the pumps in Section K3.3.

Table K2-1: CDP Best Efficiency Point

	Suction Energy Evaluation (Low / High / Very High)
CDP	High
CBP	Very High
FWP	Very High

K3.0 METHODOLOGY & ACCEPTANCE CRITERIA

K3.1 Methodology

The power train pump systems evaluated in this report are the CDPs, CBPs, FWP, and the HDPs, along with the associated HD tank control valves. Each system is analyzed through the use of a generic Fathom hydraulic model of the CD, CB, HD forwarding, and FW systems.

The condenser pressure, FW flow, HD flow, and water temperatures are taken from the PEPSE Heat Balance results documented in Attachment A. Cases are run for 1) no thermal extraction, 2) 50% thermal extraction, and 3) 50% thermal extraction with 20% LP FWH bypass.

K3.2 Computer Programs and Software

The hydraulic model used in this task report is created using Fathom Version 11.0 [Ref. K6.1]. Fathom is run on S&L PL 13761 under the Windows 10 operating system.

K3.3 Acceptance Criteria

K3.3.1 Condensate Pumps

- a) Acceptance Criterion 3.3.1a: CDP Preferred Operating Region – Under normal operation, the CDPs should operate within the POR. Per HI Standards [Ref. K6.2], the POR for horizontal centrifugal pumps is between 70% and 120% of the BEP.
- b) Acceptance Criterion 3.3.1b: CDP Driver Horsepower – The CDPs and CBPs are driven by a common motor, yet the CDPs operate at a lower speed and are driven by gearbox connected to the motor. The CDP brake horsepower (BHP) should not exceed the rated service horsepower of the gearbox.
- c) Acceptance Criterion 3.3.1c: CDP NPSH Margin – Per Table 9.6.1.1 of the HI Standard 9.6.1 [Ref. K6.3], the guideline for the minimum NPSH margin ratio for high suction energy horizontal pumps in nuclear power applications is 2.0.

K3.3.2 Condensate Booster Pumps

- a) Acceptance Criterion 3.3.2a: CBP Preferred Operating Region – Under normal operation, the CBPs should operate within the POR. Per HI Standards [Ref. K6.2], the POR for horizontal centrifugal pumps is between 70% and 120% of the BEP.

-
- b) Acceptance Criterion 3.3.2b: CBP Driver Horsepower – The CBP is directly driven by the motor common to the CDPs and CBPs. The combined CDP and CBP BHP should not exceed the rated horsepower of this motor.
 - c) Acceptance Criterion 3.3.2c: CBP NPSH Margin – Per Table 9.6.1.1 of the HI Standard 9.6.1 [Ref. K6.3], the guideline for the minimum NPSH margin ratio for very high suction energy horizontal pumps in nuclear power applications is 2.5.

K3.3.3 Heater Drain Tank Pumps (HDPs)

- a) Acceptance Criteria 3.3.3a: Preferred Operating Region – The HI Standard for the allowable operating region [Ref. K6.2] states that for a vertical pump the most conservative POR is between 80% and 115% of the BEP.
- b) Acceptance Criterion 3.3.3b: HDP Driver Horsepower – The HDP BHP should not exceed the rated horsepower of its motor.
- c) Acceptance Criterion 3.3.3c: HDP NPSH Margin – HI Standard 9.6.1 [Ref. K6.2] states that vertical turbine pumps are designed to withstand constant cavitation. Therefore, the minimum NPSH ratio for the HDPs should be 1.0, yet this evaluation will conservatively evaluate the pumps to a minimum NPSH ratio requirement of 2.0.

K3.3.4 Turbine Driven Feed Pumps

- a) Acceptance Criterion 3.3.4a: TDFP Preferred Operating Region – The HI Standard for the allowable operating region [Ref. K6.2] states that the POR for a horizontal, centrifugal pump, is between 70% and 120% of the BEP.
- b) Acceptance Criterion 3.3.4b: TDFP Driver Horsepower – The TDFP BHP should not exceed the rated horsepower of the turbine.
- c) Acceptance Criterion 3.3.4c: TDFP NPSH Margin – Per Table 9.6.1.1 of the HI Standard 9.6.1 [Ref. K6.3], the guideline for the minimum NPSH margin ratio for very high suction energy horizontal pumps in nuclear power applications is 2.5.
- d) Acceptance Criterion 3.3.4d: Turbine Driven Feed Pump Speed – The turbine should have sufficient margin below the overspeed setpoint for the TDFPs.

K3.3.5 Control Valves

- a) Acceptance Criterion 3.3.5a: HD Tank Level Control Valve Position – The HD tank control valves operate together during normal conditions to control the HD pump flow, however it is required that one valve shall pass 100% of the HD flow with margin for control (< 80% open) in the event that one of the valves is failed closed. However, during normal operation with two valves, the valve position should not exceed 50% open.

K4.0 ASSUMPTIONS

- K4.1 Fugitive Flow – An additional 1% of total FW flow is added to the analysis cases to account for flows which are present in the system, but do not reach the S/Gs. Fugitive flow represents any unaccounted flows (i.e., valve leakage) and adds conservatism to the calculation. The fugitive flow is removed from the FW system at the feed pump discharge.

K5.0 DESIGN INPUTS

- K5.1 Operating Temperatures and Flows – The FW flow, HD Pump flow, condenser backpressure, and fluid temperatures are taken from the PEPSE Heat Balance results given in Attachment A. The parameters used as input to the hydraulic model are listed below in Table K5-1.

Table K5-1: PEPSE Input

Description	Units	0%	50%	Δ (50%)	50% w/ Bypass	Δ (50% w/ Bypass)
DC 1A Discharge Temp	°F	126.3	103.9	-22.4°F	104.1	-22.2°F
FWH 1A Discharge Temp	°F	161.1	129.0	-32.1°F	130.8	-30.3°F
FWH 2A Discharge Temp	°F	210.1	170.7	-39.4°F	173.7	-36.4°F
FWH 3A Discharge Temp	°F	263.1	221.2	-41.9°F	222.9	-40.2°F
FWH 4A Discharge Temp	°F	314.3	270.2	-44.1°F	270.2	-44.1°F
DC 5A Discharge Temp	°F	331.4	283.1	-48.3°F	258.1	-73.3°F
FWH 5A Discharge Temp	°F	369.9	323.6	-46.3°F	315.6	-54.3°F
FWH 6A Discharge Temp	°F	409.5	360.9	-48.6°F	358.4	-51.1°F
FWH 7A Discharge Temp	°F	440.2	388.5	-51.7°F	386.5	-53.7°F
DC 1B Discharge Temp	°F	126.6	104.1	-22.5°F	104.3	-22.3°F
FWH 1B Discharge Temp	°F	161.7	129.4	-32.3°F	131.3	-30.4°F
FWH 2B Discharge Temp	°F	212.8	173.0	-39.8°F	175.5	-37.3°F
FWH 3B Discharge Temp	°F	265.0	223.3	-41.7°F	224.2	-40.8°F

Description	Units	0%	50%	Δ (50%)	50% w/ Bypass	Δ (50% w/ Bypass)
FWH 4B Discharge Temp	°F	316.4	272.3	-44.1°F	271.6	-44.8°F
DC 5B Discharge Temp	°F	332.2	283.9	-48.3°F	258.3	-73.9°F
FWH 5B Discharge Temp	°F	370.2	323.9	-46.3°F	316.0	-54.2°F
FWH 6B Discharge Temp	°F	409.7	361.1	-48.6°F	358.6	-51.1°F
FWH 7B Discharge Temp	°F	441.5	389.5	-52°F	387.6	-53.9°F
DC 1C Discharge Temp	°F	125.9	103.6	-22.3°F	103.8	-22.1°F
FWH 1C Discharge Temp	°F	160.8	128.7	-32.1°F	130.6	-30.2°F
FWH 2C Discharge Temp	°F	212.7	172.9	-39.8°F	175.4	-37.3°F
FWH 3C Discharge Temp	°F	264.6	222.9	-41.7°F	224.0	-40.6°F
FWH 4C Discharge Temp	°F	315.0	270.9	-44.1°F	270.7	-44.3°F
Average Condenser Pressures	in HG	2.89	1.88	-35.2%	1.88	-34.9%
Condensate Temperature	°F	115.6	98.1	-17.5°F	98.3	-17.3°F
SJAE Outlet Temp	°F	115.8	98.2	-17.6°F	98.4	-17.4°F
GSC Outlet Temp	°F	116.4	98.9	-17.5°F	99.1	-17.3°F
FW Flow ¹	lbm/hr	16,067,280	14,982,480	-6.8%	14,946,080	-7.0%
HDT Temp	°F	336.6	282.3	-54.3°F	254.7	-81.9°F
HD Flow	lbm/hr	4,732,792	3,093,006	-34.6%	3,470,571	-26.7%
HDT Pressure	psia	185.1	101.7	-45.1%	94.7	-48.8%

1) PEPSE flows do not include the 1% fugitive flow (see Assumption 4.1). Actual flows input to each feed pump are documented in Table K5-2.

K5.2 Feed Pump Flow - Based on the fugitive flow assumption (Assumption 4.1), Table K5-2 reports the actual flow values input to the FWP's for each case.

Table K5-2: Feed Pump Flows

	0%	50%	50% w/ Bypass
Final FW Flow (lbm/hr)	16,067,280	14,982,480	14,946,080
Fugitive Flow (lbm/hr)	160,673	149,825	149,461
Total Pump Flow (lbm/hr)	16,227,953	15,132,305	15,095,541
Flow per Pump (lbm/hr)	8,113,976	7,566,152	7,547,770

K6.0 REFERENCES

- K6.1 AFT Fathom™, Version 11.0, “Computer Software for Modeling Incompressible Flow in Pipe Networks,” S&L Program No. 03.7.721-11.0
- K6.2 ANSI/HI 9.6.3-1997, ‘American Nation Standard for Centrifugal/Vertical Pumps – Allowable Operating Region,’ *Hydraulic Institute*, Parsippany, NJ.
- K6.3 ANSI/HI 9.6.1-1998, “American National Standard for Centrifugal and Vertical Pumps for NPSH Margin,” *Hydraulic Institute*, Parsippany, NJ.

K7.0 EVALUATIONS

This section compares the model results for the 0% and 50% thermal extraction cases.

K7.1 Evaluation of the Preferred Operating Region

Centrifugal pumps are optimized for performance and service life at the BEP. At the BEP, hydraulic efficiency is maximized with flow entering the impeller vanes in a shockless manner. Within the POR of the pump, the flow is well controlled, and the pump will not be significantly affected by hydraulic loads, vibration, or flow separation [Ref. K6.2].

Table K7-1: Evaluation of Preferred Operating Region for 50% Thermal Extraction

Pump	Acceptance Criteria	0%	50%	Δ (50%)	50% w/ Bypass	Δ (50% w/ Bypass)
CDP	70% - 120%	109.6	114.3	4.3%	110.4	0.7%
CBP	70% - 120%	114.3	119.2	4.3%	115.1	0.7%
TDFP	70% - 120%	99.1	92.4	-6.8%	94.9	-4.3%
HDP	80% - 115%	102.8	65.1	-36.7%	72.0	-29.9%

For the CDPs, CBPs, and TDFPs, the percent BEP remains within the associated POR, and changes from the base scenario to the 50% extraction case are minimal. The HDPs experience a significant change in operating point, falling outside of the acceptance criterion by approximately 15%. With partial LP FWH bypass, this drop is not as significant, falling outside of the acceptance criterion by 8%. The HDPs will have to be evaluated on a plant-specific basis, and vendors will need to be engaged to determine whether the pumps can appropriately operate at the POR for extended durations. However, it is not expected that any equipment changes will be required.

K7.2 Evaluation of Pump Driver Duty

The power requirement for each pump to perform as hydraulically characterized in the Fathom model is reported as part of the pump performance results. The calculated BHP of the pump must not exceed the rated horsepower of the associated driver, which is a motor and gearbox for the CDPs, a motor for the CBPs, a separate motor for the HDPs, and turbines for FWPs “B” and “C”. The duty on the CDP/CBP motor is taken as the sum of the CDP and CBP required BHP, as the motor must supply enough power to drive both pumps.

Table K7-2: Evaluation of Pump Driver Duty (hp) for 50% Thermal Extraction

Pump	0%	50%	Δ (50%)	50% w/ Bypass	Δ (50% w/ Bypass)
CDP Gearbox	664	686	3.3%	670	0.9%
CDP/CBP Motor	3,157	3,253	3.0%	3,184	0.8%
TDFP Turbine	8,590	7,773	-9.5%	7,188	-16.3%
HDP Motor	1,894	1,844	-2.6%	1,900	0.3%

The duty on the CDP gearbox and CDP/CBP motor increases slightly for the 50% extraction case with no partial LP FWH bypass. These will need to be evaluated against the rated horsepower of their associated drivers. The duty on the TDFP turbine and HDP motor decreases and should continue to meet the acceptance criteria for the 50% extraction case without partial LP FWH bypass. In all cases for the partial LP FWH bypass scenario, increases are less than 1%, and should continue to meet the acceptance criteria.

K7.3 Evaluation of Net Positive Suction Head Ratio

The NPSH ratio (NPSHa/NPSHr) is a measure of the available suction head margin for a pump. The NPSHa is the net positive suction head available to a pump. The NPSHr of a pump is defined as the NPSH that will cause the total head of the pump to be reduced by 3%, due to flow blockage from cavitation vapor in the impeller vanes [Ref. K6.3]. In order to limit noise, vibration, and overall reliability, minimum NPSH ratios for each pump are established as acceptance criteria, per the guideline values in Table 9.6.1.1 of the *Hydraulic Institute Standard on Centrifugal and Vertical Pumps for NPSH Margin* [Ref. K6.3]. The required NPSH ratio for the horizontal pumps (CDP, CBP, and FWP) is determined based on the pump suction energy level. Pumps with high suction energy require higher NPSH margins than those with low suction energy. As shown in the pump descriptions (see Section K2.2), the CDPs have high suction energy, while the CBPs and FWPs have very high suction energy. Vertical pumps often operate without NPSH

margin, and only require that the NPSHa exceed the NPSHr. Though vertical pumps require an NPSH ratio of 1, a general acceptance criteria of 2.0 is used for conservatism.

Table K7-3: Evaluation of NPSH Ratio for 50% Thermal Extraction

Pump	HI / ANSI Guideline	0%	50%	Δ (50%)	50% w/ Bypass	Δ (50% w/ Bypass)
CDP	≥ 2.0	1.86	1.73	-7.4%	1.87	0.3%
CBP	≥ 2.5	2.86	2.22	-22.4%	2.75	-4.0%
TDFP	≥ 2.5	2.42	4.58	89.0%	5.59	130.7%
HDP	≥ 2.0	16.27	12.58	-22.7%	15.60	-4.1%

The NPSH ratio for the TDFPs significantly improves in both 50% thermal extraction scenarios compared to the baseline scenario. With no partial LP FWH bypass, the CDP, CBP, and HDP NPSH ratios decrease rather significantly. The CDP and CBP NPSH ratios are below the HI/ANSI guideline for both cases; nevertheless, the ~7% and ~22% decreases are not expected to significantly increase the risk of cavitation. Conversely, for the partial LP FWH bypass scenario, only the CDP NPSH ratio is below the HI/ANSI guideline, and in that case it is actually increasing, hence it should reduce the risk of cavitation compared to the baseline scenario. Although no physical changes are expected to the CDPs, CBPs, and HDPs, they should be evaluated for acceptance on a plant-specific basis for the 50% thermal extraction case. Partial LP FWH bypass is shown to improve NPSH ratio for these pumps compared to no bypass.

K7.4 Evaluation of Pump Suction and Discharge Pressure

Suction and discharge pressures for each pump are compared in Tables K7-4 and K7-5. This evaluation is used to see which pumps are at risk of falling below alarm setpoints.

Table K7-4: Pump Suction Pressures (psig) for 50% Thermal Extraction

Pump	0%	50%	Δ (50%)	50% w/ Bypass	Δ (50% w/ Bypass)
CDP	-5.1	-5.7	-5.9%	-5.6	-5.0%
CBP	99.2	93.2	-5.3%	98.2	-0.9%
TDFP	425.0	409.4	-3.5%	457.8	7.5%
HDP	184.8	102.1	-41.5%	95.3	-44.9%

Table K7-5: Pump Discharge Pressures (psig) for 50% Thermal Extraction

Pump	0%	50%	Δ (50%)	50% w/ Bypass	Δ (50% w/ Bypass)
CDP	129.5	126.2	-2.3%	129.0	-0.3%
CBP	584.3	564.8	-3.3%	582.7	-0.3%
TDFP	1,130.5	1,115.8	-1.3%	1,115.3	-1.3%
HDP	696.1	795.7	14.0%	772.4	10.7%

Overall, suction and discharge pressures remain relatively unchanged or decrease slightly for the 50% thermal extraction cases. The exceptions are the HDP suction pressure, which decreases by 40-45% under either 50% thermal extraction scenario, and the HDP discharge pressure, which increases by 10-15% for 50% thermal extraction. Suction pressures will need to be evaluated on a plant-specific basis to ensure that they do not fall below low alarm setpoints.

K7.5 Evaluation of Turbine Driven Feedwater Pump Speed

The FW flow through the pumps is regulated by the speed of the driving turbine, which receives steam from the main steam system. In the Fathom model, the turbine speed is calculated based on the required flow and developed head required of the TDFPs.

Table K7-6: Evaluation of FWP Turbine Speed (rpm) for 50% Thermal Extraction

	0%	50%	Δ (50%)	50% w/ Bypass	Δ (50% w/ Bypass)
Max Calculated Turbine Speed	5,022	4,847	-3.5%	4,702	-6.4%

The max calculated turbine speed decreases, so the margin improves for the 50% thermal extraction cases and should not challenge the TDFP speed acceptance criteria.

K7.6 Evaluation of Heater Drain Tank Level Control Valves

The heater drain tank level control valves are evaluated for controlling margin. Acceptable control margin corresponds to a valve position of less than 50% open, so that each operating valve maintains the ability to pass all of the drain flow.

Table K7-7: Heater Drain Level Control Valve Evaluation for 50% Thermal Extraction

	Acceptance Criteria	Valve Position (% Open)			Δ (50%)	Δ (50% w/ Bypass)
		0%	50%	50% w/ Bypass		
HD Level Control Valve	$\leq 50\%$	26.0	13.0	16.5	-50.2%	-36.8%

Based on these results, the HD tank level control valves meet the acceptance criteria, and the margin improves for both 50% extraction cases.

K8.0 RESULTS AND CONCLUSIONS

Analysis of the power train pumps for the 50% thermal extraction scenario shows that overall, changes from the baseline operating conditions are minimal. Pump operating point changes by less than 10% for all pumps except for the heater drain pumps which see a reduction in percent BEP of 30% to 37% with and without partial LP FWH bypass, respectively. It is not expected that any equipment changes will be needed to address this, but the HDPs will have to be evaluated with plant-specific operating conditions and design margins. Changes to pump driver duty are also small or decrease. However, the duty on the CDPs and CBPs increase and will need to be evaluated against the rated horsepower of their associated drivers on a plant-specific basis. Without partial LP FWH bypass, the CDPs and CBPs require plant-specific evaluation due to the ~7 and ~22% decrease in NPSH ratio, respectively. Conversely the 50% extraction scenario with partial LP FWH bypass sees much smaller impacts to these NPSH ratios. Although no physical changes are expected, the CDPs, CBPs, and HDPs should be evaluated for acceptance on a plant-specific basis for both 50% thermal extraction cases. It is observed that operating with partial LP FWH bypass improves pump performance compared to no bypass.

Pump suction pressures decrease for all pumps and will need to be evaluated against existing low alarm setpoints on a plant-specific basis. The exception is the TDFP suction pressure increases with partial LP FWH bypass.

The feedwater and heater drain flows are reduced, so margins for the feedwater pump turbine speed and heater drain tank level control valves improve for both thermal extraction cases.

Attachment L – Moisture Separator Reheater Evaluation with 50% Thermal Energy Extracted

Prepared: Henry Fidlow

Reviewed: Nic Richards

L1.0 PURPOSE

The purpose of this evaluation is to examine expected changes to operating conditions of the Moisture Separator Reheaters (MSRs). These changes are due to steam extraction for supplying thermal energy off-site. This evaluation is performed for two scenarios: (1) 50% thermal energy extracted from main steam, and (2) 50% thermal energy extracted from main steam with 20% condensate flow bypass around the low-pressure feedwater heaters.

L2.0 SYSTEM & COMPONENT DESCRIPTION

The MSRs take wet exhaust steam from the High Pressure Turbine (HPT) and pass it through a series of chevrons to remove moisture. The steam then goes through two stages of heat exchangers where it is heated before being sent to the Low Pressure Turbines (LPTs).

L3.0 METHODOLOGY

The operating conditions of the MSRs are evaluated for the 50% thermal extraction scenarios and compared to baseline operation. These operating conditions are taken from the PEPSE Heat Balance results documented in Attachment A. Evaluation of the MSR drains with 50% thermal energy extraction is performed in Attachment O.

L4.0 ASSUMPTIONS

None

L5.0 DESIGN INPUTS

Operating conditions are taken from the PEPSE Heat Balance results documented in Attachment A and presented in Table L7-1.

L6.0 REFERENCES

None

L7.0 EVALUATIONS

The MSR operating conditions for the baseline and 50% thermal extraction scenarios are compared in Table L7-1.

Table L7-1: MSR Operating Conditions

Description	Units	0%	50%	Δ (50%)	50% w/ Bypass	Δ (50% w/ Bypass)
MSR Removal Effectiveness	-	0.95	0.95	0.00%	0.95	0.00%
MSR Chevrons Inlet Flow	lbm/hr	3,151,396	1,668,457	-47.1%	1,561,720	-50.4%
MSR Chevrons Inlet Enthalpy	BTU/lbm	1,104	1,123	1.73%	1,119	1.37%
MSR Chevrons Inlet Pressure	psia	190.3	104.6	-45.0%	97.6	-48.7%
MSR 1st Stage Inlet Enthalpy	BTU/lbm	1,193	1,185	-0.68%	1,183	-0.79%
MSR 1st Stage Inlet Pressure	psia	184.6	101.4	-45.0%	94.7	-48.7%
MSR 2nd Stage Inlet Enthalpy	BTU/lbm	1,227	1,217	-0.81%	1,218	-0.74%
MSR 2nd Stage Inlet Pressure	psia	181.8	99.9	-45.0%	93.3	-48.7%

As shown in Table L7-1, flow to the MSRs and the pressure at each stage is reduced for the 50% thermal extraction cases, with minimal change in enthalpies. Therefore, it is not expected that the MSRs will be negatively impacted by operating with thermal extraction conditions. The 47% to 50% reduction in mass flow results in conditions similar to normal 50% thermal power with no thermal energy extraction. Partial bypassing of the low-pressure FWHs results in a small increase in pressure drop compared to no bypass, but this change is not expected to impact MSR operation.

L8.0 RESULTS AND CONCLUSIONS

The moisture separator reheaters will not be affected by operating under thermal extraction conditions. Pressures and steam flows decrease such that operating conditions are similar to 50% thermal power conditions which is an acceptable operating point for the MSRs. Partial low pressure feedwater heater bypass has negligible impact on MSR operation.

Attachment M – Feedwater Heater Evaluation with 50% Thermal Energy Extracted

Prepared: Henry Fidlow

Reviewed: Nic Richards

M1.0 PURPOSE

The purpose of this evaluation is to examine required duty and expected changes to operating conditions and performance parameters in relation to the design of the Feedwater Heaters. These changes are due to extracting steam from the nuclear power cycle main steam system to supply thermal energy to the plant boundary for off-site use. This evaluation is performed for two scenarios: (1) 50% thermal energy extracted from main steam, and (2) 50% thermal energy extracted from main steam with 20% condensate flow bypass around the low-pressure feedwater heaters.

M2.0 SYSTEM & COMPONENT DESCRIPTION

The Condensate (CD) and Feedwater (FW) Systems deliver feedwater (condensed steam) to the steam generators. The CD system first directs flow through three parallel strings of low pressure feedwater heaters (1st point external drain cooler and 1st through 4th point heaters). Flow then passes through two parallel strings of low pressure feedwater heaters (5th point external drain cooler, 5th and 6th point heaters) to the turbine driven steam generator feed pumps (SGFP). FW flow then continues through two parallel high pressure feedwater heaters (7th point heaters) to the steam generators. The feedwater heaters receive extraction steam flow and moisture separator reheater drain flow from the main turbine system.

M3.0 METHODOLOGY AND ACCEPTANCE CRITERIA**M3.1 Methodology****M3.1.1 Tube Side Nozzle Velocity**

The water velocity in these nozzles must be limited to minimize metal erosion in the head and tube sheet areas caused by feedwater impingement. The velocity used with the HEI guidelines [Ref. M6.2] is based on the density of liquid water at 60°F.

M3.1.2 Tube Velocity

In order to avoid excessive tube erosion, the tube velocity should be limited. The flow area is based on the total number of tubes for each pass minus the number of plugged tubes. In accordance with HEI guidelines [Ref. M6.2], the density used in computing the tube velocity is based on the density of liquid water at the average tube temperature.

M3.1.3 Tube Side Pressure Drop and Partition Plate Differential Pressure

The tube side pressure drop principally affects two design issues, (i) the differential pressure across the pass partition plate (PPP), and (ii) the total pressure drop in the feedwater train. The pass partition plate is integral to the head of the feedwater heater, and separates the fluid entering the first tube pass from the fluid exiting the second tube pass. Moderately high differential pressures across the PPP can cause cracking of the welds in the plate or displacement of the partition gasket, which results in leakage and reduced heater performance. No guidelines are stated in HEI for the differential pressure across the PPP. Additional pressure loss in the feedwater train impacts the power train pumps, which are evaluated for 50% thermal extraction in Attachment K.

HEI [Ref. M6.2] provides an approximate method of calculating total tube side pressure drop, which consists of the sum of the following terms (see definitions below):

$$\Delta P_{total} = \Delta P_{tubes} + \Delta P_{NI} + \Delta P_{NO} + \Delta P_E \quad (Eq. M3-1)$$

where:

- ΔP_{total} -total tube side pressure drop, psid
- ΔP_{tubes} -pressure loss through tubes, psid
- ΔP_{NI} -pressure loss through channel inlet nozzle, psid
- ΔP_{NO} -pressure loss through channel outlet nozzle, psid
- ΔP_E -tube entrance, exit, and turning losses, psid

Pressure loss across inlet channel and outlet nozzle do not impact the pressure loss across the pass partition plate. Therefore, only the pressure loss through the tubes and the tube entrance, exit, and turning losses impact the PPP pressure drop.

These pressure drops are defined as follows from the HEI standards [Ref. M6.2]:

 ΔP Inside Tubes

$$\Delta P_{tubes} = \frac{1.396 \times 10^{-7}}{C} \cdot f \cdot \left(\frac{w}{A_t} \right)^2 \cdot \frac{L}{d} \quad (Eq. M3-2)$$

where:

$$f = 0.0014 + 0.125 \cdot Re^{-0.32}$$

$$Re = \frac{w \cdot d}{0.201389 \cdot \mu \cdot A_t}$$

Tube Entrance, Exit, and Turn Losses

$$\Delta P_E = \frac{2.896 \times 10^{-9}}{C} \cdot K_t \cdot \left(\frac{w}{A_t} \right)^2 \cdot \frac{N}{2} \quad (Eq. M3-3)$$

where:

w	- feedwater mass flow rate, lb _m /hr
L	- total length of tube travel, ft
A_t	- flow area of tubes per pass accounting for tube plugging, in ²
d	- nominal inside diameter of tubes, in
C	- density correction factor from Fig. 3a [Ref. M6.2]
f	- friction factor
K_t	- loss correction factor for tube configuration from Fig. 3b [Ref. M6.2]
N	- number of tube passes
Re	- Reynolds number for individual tube at calculated flow rate per tube
μ	- tube side absolute viscosity, centipoise

Review of Equations M3-2 and M3-3 show most factors are based on the physical design of the FWH and are not sensitive to changes in operating conditions. The density correction factor and friction factor are slightly impacted, but over the range of operating conditions expected, the impact is inconsequential compared to the change in feedwater mass flow rate (which is a squared term). Therefore, to review the impact on PPP pressure loss, only the change in mass flow rate squared is reviewed.

M3.1.4 Steam Inlet and Drain Outlet Nozzle Velocity

Steam velocities entering the shell side of the heater must be limited in order to prevent overstressing of the impingement plate, erosion damage (i.e., to the impingement plate, tube support plates, and heater shell) and to control vibration of the tubes in the high velocity regions where steam is introduced to the tube bundle. Steam velocity is based on the fluid conditions from the heat balance, and it is compared against the recommended limit from the HEI standard [Ref. M6.2].

The steam velocity entering the heater is the mass flow rate of steam entering the heater from the heat balance, divided by the density of the steam, divided by the flow area of a single steam inlet nozzle, divided by the number of steam inlet nozzles per heater.

The velocity in the condensate drain outlet nozzle is calculated as the mass flow rate from the heat balance, divided by the density of liquid discharging from the heater, divided by the flow area of the drain nozzle.

M3.1.5 Drain Inlet Nozzle Mass Flux

The limits for this parameter are provided to minimize and/or avoid the following:

- erosion of the inlet nozzle and heater shell areas adjacent to the nozzle,
- structural damage to the impingement plate and adjacent tube support plates,
- tube degradation in the areas adjacent to the impingement plate, and
- vibration of tubes in high velocity regions where the two-phase mixture is introduced to the tube bundle.

HEI characterizes the inlet conditions through the use of a mass flux parameter, which is equal to the square of the mass flux rate divided by the fluid inlet density. The density is evaluated using the inlet enthalpy and heater shell pressure from the heat balance.

M3.1.6 Operating Pressure and Temperature

Tube side and shell side operating temperatures and shell side pressures for the baseline and 50% thermal extraction cases are compared to determine the impact on design value margin. These parameters are taken from the heat balances in Attachment A.

M3.1.7 Drain Cooler Tube Vibration

The main sources of vibration in drain coolers are vortex shedding and fluidelastic whirling [Ref. M6.3]. In order to prevent resonant tube vibration from vortex shedding, the natural frequency of the unsupported tube span should remain larger than the vortex shedding frequency. TEMA requires that the natural frequency exceed the vortex shedding frequency. The natural frequency of the tube span is dependent on the physical design of the FWH and is therefore not impacted by changes to operating conditions associated with operating with thermal power extraction. The vortex shedding frequency is proportional to the cross flow velocity at the tubes. Since the cross flow area will not change with thermal power extraction, the total volumetric drain cooler flow is reviewed for changes due to operation with 50% thermal energy extraction.

Another possible mechanism for vibrational damage is fluidelastic whirling. This process occurs when the displacement of one tube alters the flow field resulting in forces on other tubes. If the exciting force from the flowing fluid exceeds damping, the self-excited vibration will set up. In order to prevent this excitation, the critical whirling velocity must exceed the cross flow velocity. The critical velocity is calculated using the methodology of TEMA [pages 94 & 95, Ref. M6.3].

A review of the TEMA equations shows that the critical velocity is based on physical parameters with a minor relationship to density. As the density is not significantly changing in the drain cooler due to operation with thermal power extraction, critical velocity can be considered constant for the purposes of this evaluation. Therefore, as with vortex shedding, only the cross flow velocity will be impacted by reviewing the total volumetric drain cooler flow changes due to operation with 50% thermal energy extraction.

M3.2 **Acceptance Criteria**

M3.2.1 Acceptance Criterion 1 – Tube side nozzle velocity should be less than 10 ft/s, according to HEI [Ref. M6.2].

M3.2.2 Acceptance Criterion 2 – Tube velocity should be less than 10 ft/s, according to HEI [Ref. M6.2].

M3.2.3 Acceptance Criterion 3 – Steam inlet nozzle velocity should be less than the HEI recommendation:

$$V \leq \frac{250}{P_{STEAM}^{0.09}} \quad (Eq. M3-4)$$

M3.2.4 Acceptance Criterion 4 – Condensate drain outlet velocity should be less than the HEI recommendation [Ref. M6.2] as follows:

- 4 ft/sec for sub-cooled drains,
- 4 ft/sec for saturated drains with level control in the heater, and
- 2 ft/sec for saturated drains where the level is not controlled in the heater

Velocity in the heater drain outlet nozzle must be limited to (a) avoid excessive drag loads on drain cooler tubes in the vicinity of the nozzle, and (b) prevent flashing in the downstream piping connected to the heater outlet nozzle.

M3.2.5 Acceptance Criterion 5 – Drain inlet nozzle mass flux G should be limited to the following according to HEI [Ref. M6.2]:

$$G \leq 250 \text{ lb}_m/\text{sec}/\text{ft}^2 \quad (\text{Eq. M3-5})$$

$$\frac{G^2}{\rho} \leq 4000 \text{ lb}_m/\text{ft}/\text{sec}^2 \quad (\text{Eq. M3-6})$$

M3.2.6 Acceptance Criterion 6 – In order to be acceptable for tube vibration, the following criteria must be met:

- $f_n/f_e > 1$, in order to prevent resonant vortex shedding frequencies [Ref. M6.3]
- $V_{crit}/V > 1$, in order to prevent excessively large vibration amplitudes [Ref. M6.3]

As discussed in Section M3.1.7, the natural frequency and critical velocity can be considered constant relative to changes in operating conditions. Similarly, the vortex shedding frequency and cross flow velocity are directly proportional to drain cooler volumetric flow. Therefore, if drain cooler volumetric flow decreases, margins to the ratio criteria will increase.

M4.0 ASSUMPTIONS

None.

M5.0 DESIGN INPUTS

M5.1 Operating Conditions – Mass flow rates, pressures, temperatures, and enthalpies for various operating parameters are taken from the PEPSE results given in Attachment A.

M5.2 Feedwater Heater Tubes – The number of tubes, tube dimensions, total length of tube travel, design tube pressure drop, and percent tube plugging are given in Table M5-1 based on typical plant data.

Attachment M
Feedwater Heater Evaluation – 50% Thermal Extraction

Table M5-1: FWH Tube Side Dimensions

Heater Nos	# of Tubes	Tube Size	Thickness (in)	Tube I.D. (in)	Total Tube Length (ft)	Pressure Drop (psi)	Tube Plugging (-)
1 st EDC	396	1	0.035	0.930	15' 5"	6.6	15%
1 st Point	1201	5/8	0.035	0.555	33' 8"	15	5%
2 nd Point	797	3/4	0.035	0.680	46' 11"	15.7	5%
3 rd Point	767	3/4	0.035	0.680	42' 7"	15.1	5%
4 th Point	673	7/8	0.035	0.805	39' 7"	8.6	5%
5 th EDC	2798	5/8	0.035	0.555	13' 8"	3.1	15%
5 th Point	1842	3/4	0.035	0.680	29' 3"	10.5	5%
6 th Point	2037	3/4	0.035	0.680	33' 3"	9.4	5%
7 th Point	3583	5/8	0.058	0.509	24' 2"	10.9	5%

M5.3 Nozzle Sizes – The heater nozzle dimensions and the number of nozzles of each type are given in Table M5-2 based on typical plant data.

Table M5-2: FWH Nozzle Sizes

Heater Nos	Feedwater Inlet Nozzles		Feedwater Outlet Nozzles		Extraction Steam Nozzles			Inlet Drain Nozzles		Outlet Drain Nozzles	
	Dia (in)	I.D. (in)	Dia (in)	I.D. (in)	Qty.	Dia (in)	I.D. (in)	Dia (in)	I.D. (in)	Dia (in)	I.D. (in)
1 st EDC	18"	16.12	18"	16.12	-	-	-	18"	17.250	18"	17.25
1 st Point	18"	16.12	18"	16.12	4	30"	29.00	-	-	10"	10.02
2 nd Point	18"	16.12	18"	16.12	2	28"	27.00	12"	11.750	14"	13.25
3 rd Point	18"	16.12	18"	16.12	2	18"	17.00	8"	7.625	12"	12.00
4 th Point	18"	16.12	18"	16.12	1	20"	19.00	-	-	8"	7.98
5 th EDC	24"	21.56	24"	21.56	-	-	-	30"	29.250	30"	29.25
5 th Point	28"	26.13	28"	26.13	1	22"	20.25	See Note 1	See Note 1	26"	25.25
6 th Point	28"	26.13	28"	26.13	1	18"	16.88	18"	17.00	20"	19.25
7 th Point	28"	25.4	24"	20.4	1	14"	13.12	10" (x2)	9.562	18"	17.25

¹The fifth point FWHs have an 18-inch nozzle for cascading FWH drains (ID = 17.000") and two 8-inch nozzle for drains from each first stage reheater drain tank (ID = 7.625").

M6.0 REFERENCES

- M6.1 STMFUNC (Steam Table Function Dynamic Link Library) S&L Program Number 03.7.598 2.0, dated 06-11-2018.
- M6.2 Standards for Closed Feedwater Heaters. Heat Exchange Institute, Inc. Sixth Edition, 1998.
- M6.3 Standards of the Tubular Exchanger Manufacturers Association, Tubular Exchanger Manufacturers Association, Inc. Seventh Edition, 1988.

M7.0 EVALUATIONS**M7.1 Evaluation of Condensate/Feedwater Nozzle Velocities**

The following channel end nozzle velocities were computed for the feedwater heaters.

Table M7-1: Condensate/Feedwater Heater Nozzle Velocities (ft/s) for 50% Thermal Extraction

FW Heater	HEI Limit	Baseline (0% Extraction)	50% Extraction	Δ (50%)	50% Extraction w/ Bypass	Δ (50% w/ Bypass)
1 st EDC	10	11.9	12.5	4.9%	12.0	1.2%
1 st Point	10	11.9	12.5	4.9%	12.0	1.2%
2 nd Point	10	11.9	12.5	4.9%	12.0	1.2%
3 rd Point	10	11.9	12.5	4.9%	12.0	1.2%
4 th Point	10	11.9	12.5	4.9%	12.0	1.2%
5 th EDC	10	10.0	10.4	4.9%	10.1	1.2%
5 th Point	10	9.6	9.0	-6.8%	8.9	-7.0%
6 th Point	10	9.6	9.0	-6.8%	8.9	-7.0%
7 th Point Inlet	10	10.2	9.5	-6.8%	9.5	-7.0%
7 th Point Outlet	10	15.8	14.7	-6.8%	14.7	-7.0%

Tube side nozzle velocities exceed the HEI guidelines for several of the FWHs, but changes from the baseline case are small or decrease. Therefore, it is not expected that feedwater nozzle wear will be an issue due to these changes.

M7.2 Evaluation of Tube Velocities

The following tube velocities were computed for the feedwater heaters. They are based on the density using the average tube temperature.

Table M7-2: Tube Velocity (ft/s) for 50% Thermal Extraction

FW Heater	HEI Limit	Baseline (0% Extraction)	50% Extraction	Δ (50%)	50% Extraction w/ Bypass	Δ (50% w/ Bypass)
1 st EDC	10	10.7	11.2	4.4%	10.8	0.8%
1 st Point	10	8.9	9.3	4.1%	9.0	0.5%
2 nd Point	10	9.1	9.4	3.6%	9.1	0.1%
3 rd Point	10	9.6	9.9	3.1%	9.6	-0.4%
4 th Point	10	8.1	8.3	2.6%	8.0	-0.9%
5 th EDC	10	7.0	7.1	2.2%	6.8	-2.8%
5 th Point	10	9.1	8.3	-9.4%	8.2	-10.4%
6 th Point	10	8.5	7.6	-9.7%	7.6	-10.3%
7 th Point	10	8.8	7.9	-10.3%	7.9	-10.7%

Tube velocities remain below or marginally exceed the HEI guidelines for the 50% thermal extraction cases. Since changes are small, it is not expected that this will impact FWH tube degradation.

M7.3 Tube Side Pressure Drop

The following change in mass flow rates are used to evaluate the impact on PPP pressure loss based on the methodology outlined in Section M3.1.3. As the mass flow rate term is squared in the pressure loss equations, the ratio of flow rates is squared to determine the percent change in PPP pressure drop.

Table F7-3: Pass Partition Plate Pressure Loss for 50% Thermal Extraction

FW Heater	Baseline (0% Extraction) (lbm/hr)	50% Extraction (lbm/hr)	Ratio of Flow Rates (50%/Baseline)	Ratio of Flow Rates Squared (50%/Baseline) ²	PPP dP % Change
1 st EDC	3,778,163	3,963,150	105%	110%	10%
1 st Point	3,778,163	3,963,150	105%	110%	10%
2 nd Point	3,778,163	3,963,150	105%	110%	10%
3 rd Point	3,778,163	3,963,150	105%	110%	10%
4 th Point	3,778,163	3,963,150	105%	110%	10%
5 th EDC	5,667,245	5,944,725	105%	110%	10%
5 th Point	8,033,640	7,491,240	93%	87%	-13%
6 th Point	8,033,640	7,491,240	93%	87%	-13%
7 th Point	8,033,640	7,491,240	93%	87%	-13%

Table F7-4: Pass Partition Plate Pressure Loss for 50% Thermal Extraction with LP FWH Bypass

FW Heater	Baseline (0% Extraction) (lbm/hr)	50% Extraction w/ Bypass (lbm/hr)	Ratio of Flow Rates (50% with Bypass/Baseline)	Ratio of Flow Rates Squared (50% with Bypass/Baseline) ²	PPP dP % Change
1 st EDC	3,778,163	3,825,167	101%	103%	3%
1 st Point	3,778,163	3,825,167	101%	103%	3%
2 nd Point	3,778,163	3,825,167	101%	103%	3%
3 rd Point	3,778,163	3,825,167	101%	103%	3%
4 th Point	3,778,163	3,825,167	101%	103%	3%
5 th EDC	5,667,245	5,737,750	101%	103%	3%
5 th Point	8,033,640	7,473,040	93%	87%	-13%
6 th Point	8,033,640	7,473,040	93%	87%	-13%
7 th Point	8,033,640	7,473,040	93%	87%	-13%

The pressure loss across the PP is expected to increase in FWHs 1 through 4 and both external drain coolers. However, the expected increase in tube side pressure drop for the 50% thermal extraction cases is not expected to appreciably impact reliable operation of the heaters. This increase is less pronounced in the partial LP FWH bypass scenario compared to the case with no bypass.

M7.4 Steam Inlet and Drain Outlet Nozzle Velocity

The following steam inlet and drain outlet nozzle velocities were computed for the feedwater heaters.

Table M7-5: Steam Inlet Nozzle Velocity (ft/s) for 50% Thermal Extraction

FW Heater	HEI Limit	Baseline (0% Extraction)	50% Extraction	Δ (50%)	50% Extraction w/ Bypass	Δ (50% w/ Bypass)
1 st Point	215	137	215	57.3%	175	27.8%
2 nd Point	195	148	272	83.7%	215	45.0%
3 rd Point	179	179	348	94.5%	269	50.3%
4 th Point	167	156	287	84.5%	224	44.1%
5 th Point	156	101	183	80.8%	282	178.6%
6 th Point	150	103	150	45.6%	174	69.5%
7 th Point	146	80	91	13.5%	98	22.4%

Table M7-6: Drain Outlet Nozzle Velocity (ft/s) for 50% Thermal Extraction

FW Heater	HEI Limit	Baseline (0% Extraction)	50% Extraction	Δ (50%)	50% Extraction w/ Bypass	Δ (50% w/ Bypass)
1 st EDC	4.0	2.3	1.9	-18.4%	1.5	-36.7%
1 st Point	4.0	1.8	1.1	-40.0%	0.9	-49.2%
2 nd Point	4.0	2.9	2.6	-11.2%	1.9	-32.7%
3 rd Point	4.0	2.4	2.2	-6.8%	1.7	-30.6%
4 th Point	4.0	2.8	2.6	-8.07%	1.9	-32.0%
5 th EDC	4.0	1.8	1.3	-25.0%	1.5	-14.9%
5 th Point	4.0	2.5	1.9	-25.3%	2.1	-14.3%
6 th Point	4.0	2.7	2.0	-25.1%	2.1	-22.5%
7 th Point	4.0	2.2	1.6	-26.7%	1.6	-28.4%

For the 50% thermal extraction scenario with no LP FWH bypass, steam inlet nozzle velocities increase for all FWHs and exceed the HEI guideline for the 2nd, 3rd, 4th, and 5th point heaters. For the 50% thermal extraction scenario with partial LP FWH bypass, steam inlet nozzle velocities increase for all FWHs and exceed the HEI guideline for the 2nd, 3rd, 4th, 5th, and 6th point heaters. The increases in velocity on the 2nd, 3rd, and 4th point heaters are greater for the scenario with no LP FWH bypass, while the 5th and 6th point heater inlet nozzle velocities are greater for the partial LP FWH bypass scenario. Shell wear rates will likely increase, and it should be noted that changes to steam inlet velocity can affect the wear pattern of the shell. Future inspections should be mindful of these changes. Flow accelerated corrosion (FAC) evaluations should be performed to determine the operating impacts of these increased velocities.

Drain outlet velocities decrease for both thermal extraction cases, so HEI guidelines are not challenged, and wear rates may decrease.

M7.5 Drain Inlet Nozzle Mass Flux

The mass flux and mass flux parameter of flashing condensate flows entering the shell side of the feedwater heaters are shown in Tables M7-7 and M7-8 for each of the 50% thermal extraction scenarios.

Table M7-7: Heater Drain Inlet Nozzle Mass Flux and Mass Flux Parameter for 50% Thermal Extraction

FW Heater	Mass Flux (lbm/s/ft ²)				Mass Flux Parameter (lbm/ft/s ²)			
	HEI Limit	Baseline (0% Extraction)	50% Extraction	Δ (50%)	HEI Limit	Baseline (0% Extraction)	50% Extraction	Δ (50%)
1 st EDC	250	141	116	-18.0%	4,000	4,755	3,704	-22.1%
2 nd Point	250	148	140	-5.3%	4,000	6,491	7,663	18.1%
3 rd Point	250	179	168	-6.1%	4,000	4,141	5,177	25.0%
5 th EDC	250	102	78	-23.0%	4,000	190	109	-42.4%
5 th Point (cascading)	250	188	145	-22.6%	4,000	647	375	-42.0%
5 th Point (MSR)	250	119	56	-53.1%	4,000	4,409	1,480	-66.4%
6 th Point	250	118	90	-23.7%	4,000	515	291	-43.6%
7 th Point	250	112	96	-13.9%	4,000	2,177	3,878	78.1%

Table M7-8: Heater Drain Inlet Nozzle Mass Flux and Mass Flux Parameter for 50% Thermal Extraction with LP FWH Bypass

FW Heater	Mass Flux (lbm/s/ft ²)				Mass Flux Parameter (lbm/ft/s ²)			
	HEI Limit	Baseline	50% Extraction w/ Bypass	Δ (50% w/ Bypass)	HEI Limit	Baseline	50% Extraction w/ Bypass	Δ (50% w/ Bypass)
1 st EDC	250	141	90	-36.4%	4,000	4,755	1,385	-70.9%
2 nd Point	250	148	105	-29.3%	4,000	6,491	3,249	-49.9%
3 rd Point	250	179	125	-30.4%	4,000	4,141	2,139	-48.4%
5 th EDC	250	102	90	-11.3%	4,000	190	144	-24.0%
5 th Point (cascading)	250	188	151	-19.6%	4,000	647	403	-37.7%
5 th Point (MSR)	250	119	56	-53.4%	4,000	4409	1,632	-63.0%
6 th Point	250	118	88	-25.4%	4,000	515	261	-49.4%
7 th Point	250	112	91	-18.8%	4,000	2,177	3,549	63.0%

For the 50% thermal extraction case with no LP FWH bypass, drain inlet mass fluxes remain below HEI guidelines, but the mass flux parameters for the 2nd and 3rd point heaters exceed the guidelines. Under the partial LP FWH bypass scenario, none of the mass fluxes or mass flux parameters exceed HEI guidelines.

Attachment M
Feedwater Heater Evaluation – 50% Thermal Extraction

For most FWHs, the mass flux parameter decreases, or the increase is small (<25%). The FWH 7 inlet mass flux parameter increases by ~60-80% between the two scenarios, and is caused by the change in density from the lower shell pressure. If the subject station does not show sufficient margin to allow for this increase, the additional flashing steam could increase wear rates at the drain inlet and future inspections should be mindful for changes.

M7.6 Operating Pressure and Temperature

Shell side operating pressure and tube side and shell side operating temperatures are compared for the baseline and 50% thermal extraction cases in Tables M7-9 through M7-11. The shell side operating temperature is the saturation temperature of steam at the operating shell side pressure.

Table M7-9: Shell Side Operating Pressures (psia) for 50% Thermal Extraction

FW Heater	Baseline (0% Extraction)	50% Extraction	Δ (50%)	50% Extraction w/ Bypass	Δ (50% w/ Bypass)
1 st EDC	5.4	2.4	-55.1%	2.5	-54.4%
1 st Point	5.4	2.4	-55.1%	2.5	-54.4%
2 nd Point	15.9	7.3	-54.0%	7.3	-54.0%
3 rd Point	40.6	19.7	-51.5%	19.4	-52.3%
4 th Point	89.5	46.8	-47.8%	44.7	-50.0%
5 th EDC	186.1	102.3	-45.0%	95.5	-48.7%
5 th Point	186.1	102.3	-45.0%	95.5	-48.7%
6 th Point	287.1	161.3	-43.8%	157.5	-45.1%
7 th Point	408.7	229.2	-43.9%	224.5	-45.1%

Table M7-10: Shell Side Operating Temperatures (°F) for 50% Thermal Extraction

FW Heater	Baseline (0% Extraction)	50% Extraction	Δ (50%)	50% Extraction w/ Bypass	Δ (50% w/ Bypass)
1 st EDC	165.6	133.3	-32.3°F	133.9	-31.7°F
1 st Point	165.6	133.3	-32.3°F	133.9	-31.7°F
2 nd Point	215.9	178.8	-37.1°F	178.8	-37.1°F
3 rd Point	268.1	227.1	-41.0°F	226.2	-41.8°F
4 th Point	319.9	276.8	-43.1°F	274.1	-45.8°F
5 th EDC	375.8	329.5	-46.4°F	324.5	-51.3°F
5 th Point	375.8	329.5	-46.4°F	324.5	-51.3°F
6 th Point	413.3	364.2	-49.1°F	362.3	-51.1°F
7 th Point	446.7	393.4	-53.3°F	391.6	-55.1°F

Attachment M
Feedwater Heater Evaluation – 50% Thermal Extraction

Table M7-11: Tube Side Operating Temperatures (°F) for 50% Thermal Extraction

FW Heater	Baseline (0% Extraction)	50% Extraction	Δ (50%)	50% Extraction w/ Bypass	Δ (50% w/ Bypass)
1 st EDC	126.6	103.9	-22.4°F	104.1	-22.2°F
1 st Point	161.7	129.0	-32.1°F	130.8	-30.2°F
2 nd Point	212.8	170.7	-39.5°F	173.7	-36.4°F
3 rd Point	265.0	221.2	-41.9°F	222.9	-40.2°F
4 th Point	316.4	270.2	-44.2°F	270.2	-44.1°F
5 th EDC	332.2	283.1	-48.3°F	258.1	-73.3°F
5 th Point	370.2	323.6	-46.3°F	315.6	-54.3°F
6 th Point	409.7	360.9	-48.6°F	358.4	-51.1°F
7 th Point	441.5	388.5	-51.8°F	386.5	-53.7°F

Operating temperatures and pressures decrease for all FWHe, so margins to design values will improve for the thermal extraction cases.

M7.7 Drain Cooler Tube Vibration

Tube vibration in the 1st through 7th point heater drain coolers is evaluated by comparing the drain cooler volumetric flow rates.

Table M7-12: Drain Cooler Vibration for 50% Thermal Extraction

FW Heater No.	Drain Volumetric Flow (gpm)				
	Baseline (0% Extraction)	50% Extraction	Δ (50%)	50% Extraction w/ Bypass	Δ (50% w/ Bypass)
1 st EDC	1,671	1,364	-18.4%	1,058	-36.7%
2 nd Point	1,240	1,101	-11.2%	835	-32.7%
3 rd Point	842	784	-6.8%	585	-30.6%
4 th Point	439	404	-8.1%	299	-32.0%
5 th EDC	3,767	2,826	-25.0%	3,205	-14.9%
6 th Point	2,434	1,824	-25.1%	1,887	-22.5%
7 th Point	1,578	1,157	-26.7%	1,130	-28.4%

As shown in Table M7-12, the volumetric flow through all drain coolers is expected to decrease during operation with 50% thermal extraction, resulting in increased margin for tube vibration parameters. Therefore, tube vibration is not expected to be caused by operating with 50% thermal extraction.

M8.0 RESULTS AND CONCLUSIONS

Tube and tube side nozzle velocities exceed the HEI guidelines for several of the FWHs, but changes from the baseline case are small or decrease, so it is not expected that FWH tube degradation or nozzle wear will be an issue due to 50% thermal extraction. Steam inlet nozzle velocities for both 50% thermal extraction cases increase for all FWHs and exceed the HEI guidelines for the 2nd, 3rd, 4th, 5th, and 6th (for partial LP FWH bypass scenario only) point heaters, so shell wear rates will likely increase. This increase is more pronounced for the partial LP FWH bypass scenario on the 5th and 6th heaters, while the increase is greater for the scenario with no LP FWH bypass on the 2nd, 3rd, and 4th point heaters. It should also be noted that changes to steam inlet velocity can affect the wear pattern of the shell, and future inspections should be mindful for changes. Flow accelerated corrosion (FAC) evaluations should be performed to determine the operating impacts of these increased velocities. Drain outlet velocities decrease for the 50% thermal extraction cases, so HEI guidelines are not challenged, and wear rates may decrease.

The pressure loss across the pass partition plate is expected to increase in FWHs 1 through 4 and both external drain coolers. However, the expected increase in tube side pressure drop for the 50% thermal extraction cases is not expected to appreciably impact reliable operation of the heaters.

For the 50% thermal extraction case with no bypass, drain inlet mass fluxes remain below HEI guidelines, but the mass flux parameters for the 2nd and 3rd point heaters exceed the guidelines. Under the partial LP FWH bypass scenario, none of the mass fluxes or mass flux parameters exceed HEI guidelines.

For most FWHs, the mass flux parameter decreases, or the increase is small (<25%). The FWH 7 inlet mass flux parameter increases by 60-80% across the two scenarios, due to the change in density from the lower shell pressure. If the subject station does not show sufficient margin to allow for this increase, the additional flashing steam could increase wear rates at the drain inlet. Future inspections should be mindful of these changes.

Operating temperatures and pressures decrease for all FWHs, so margins to design values will improve for the thermal extraction cases. Volumetric flow through all drain coolers is also expected to decrease during operation with 50% thermal extraction, resulting in increased margin for tube vibration parameters. Therefore, tube vibration is not expected to be caused by operating with 50% thermal extraction.

Attachment N - Extraction Steam Evaluation with 50% Thermal Energy Extracted

Prepared: Henry Fidlow

Reviewed: Nic Richards

N1.0 PURPOSE

The purpose of this evaluation is to examine expected changes to operating conditions and performance parameters in relation to the design of the Extraction Steam (ES) System. This evaluation is performed for two scenarios: (1) 50% thermal energy extracted from main steam, and (2) 50% thermal energy extracted from main steam with 20% condensate flow bypass around the low-pressure feedwater heaters.

N2.0 SYSTEM & COMPONENT DESCRIPTION

To maximize steam cycle efficiency, the ES System diverts steam taken from the turbine to the feedwater heaters. There are three stages of extraction from the High Pressure (HP) turbine, and four stages of extraction from each Low Pressure (LP) turbine. The Extraction Steam is used to heat the feedwater in seven separate feedwater heater stages.

There are three trains for the 1st through 4th point LP feedwater heaters, two trains for the 5th and 6th point LP feedwater heaters, and two trains for the 7th point HP feedwater heater.

N3.0 METHODOLOGY

N3.1 Methodology

N3.1.1 Extraction Steam Lines Pressure Drop

Pressure drop in the ES lines will be evaluated using simplified incompressible flow methodology based on the Crane Technical Paper [pp. 3-4, Ref. N6.3]. The following equation will be utilized to estimate the ES lines pressure drop:

$$\Delta P = 2.80 \times 10^{-7} \frac{KW^2 v}{d^5} \quad \text{Eq. N3-1}$$

where:

- ΔP = Pressure Drop [psi]
- K = Resistance Coefficient [ul]
- W = Mass Flow Rate [lbm/hr]
- v = Specific Volume [ft³/lbm]
- d = Piping Inside Diameter [in]

The K value for each segment of the ES piping, the saturation pressures of each feedwater heater shell, and the total mass flow rate of the ES from the PEPSE evaluation in Attachment A will be used to compute the pressure drop for each available line.

N3.1.2 Operating Conditions

ES line pressures and temperatures from the PEPSE analysis in Attachment A are compared for the baseline and 50% thermal extraction scenarios (with and without partial low pressure feedwater heater bypass). These comparisons are used to generalize the impacts on relevant valve and expansion joint service conditions.

N3.1.3 Extraction Steam Expansion Joint Liner Thickness

The required expansion joint liner thicknesses for the baseline and 50% extraction cases are calculated using the following methodology and compared. Based on Section 4.10.2 of the EJMA standard [Ref. N6.1], the minimum liner thickness for expansion joints between 12 to 24-inch diameters is 0.048-in and 0.060-in for diameters of 26 to 48-in. When the internal sleeve length exceeds 18-in, the standard liner thickness is to be multiplied by $(L/18)^{0.5}$ where L is the internal sleeve length in inches. When the flow velocity exceeds 100 ft/sec, the standard liner thickness is to be multiplied by $(V/100)^{0.5}$ where V is the liner velocity and is computed by (equation per page 3-2, [Ref. N6.3]):

$$V = 0.0509 \frac{Wv}{d^2}$$

Eq. N3-2

where:

- V = Mean Velocity of Flow [ft/sec]
- W = Mass Flow Rate [lb_m/hr]
- v = Specific Volume [ft³/lb_m]
- d = Piping Inside Diameter [in]

Where extremely turbulent flow is generated within 10 pipe diameters upstream of the expansion joint by valves, tees, and elbows, the flow velocity used in calculating the liner thickness shall be determined by multiplying the actual flow velocity by four [Ref. N6.1]. Since the expansion joint assemblies have high Reynolds's numbers, the 'turbulent flow multiplier' is used.

When the fluid temperature exceeds 300°F, the thickness increase factor shall be equal to E_{sc}/E_{sh} where E_{sc} is the internal sleeve modulus of elasticity at 300°F and E_{sh} is the internal sleeve modulus of elasticity at the media temperature [Ref. N6.1]. The only extraction line that experiences temperatures above 300°F is FWH 4 and the change in modulus of elasticity due to temperature change at baseline to 50% thermal power extraction conditions is expected to be negligible. Therefore, the temperature increase factor is ignored.

N4.0 ASSUMPTIONS

N4.1 Pressure Drop – Pressure loss is computed based on incompressible flow equations. Per Crane [Ref. N6.3], if the calculated pressure drop is less than about 10% of the inlet pressure, reasonable accuracy will be obtained if specific volume is based on either upstream or downstream conditions. Similarly, for pressure drop between 10% and 40% of inlet pressure, specific volume based on the average upstream and downstream conditions can be used. For conservatism, the specific volume of steam/steam water mixture is based on the feedwater heater shell pressure and the turbine extraction point enthalpy. Using the end-point pressure to determine specific volume is conservative with respect to pressure drop and line velocity.

N4.2 Flow Rate – It is assumed that the flow rate is equal in all heater trains from the HP Turbine. The flow rate is used as input for the calculation of ES line pressure drop. While some flow variation between trains may exist, it will affect the losses associated with piping to only a small degree. The piping loss is a very small part of the total line loss, which accounts for losses due to various components such as elbows and valves. Loss factors for these components are typically conservative in nature. Also note that the higher flow from either string from the PEPSE analysis (see Attachment A) is used. This should provide adequate allowance and margin for differences between heater strings.

N5.0 DESIGN INPUTS

N5.1 Operating Parameters

ES flows, temperatures, pressures, and enthalpies are taken from the PEPSE results given in Attachment A. For this analysis, the maximum values for mass flow, pressure, and enthalpy from the three strings for FWHs 1-4 are used. The pressure subscripts 'US' and 'DS' indicate upstream and downstream, respectively. Specific volume is based on downstream pressure, yielding a higher result which is conservative with respect to flow velocity. This is consistent with Assumption N4.1. Temperature is based on upstream pressure, yielding a higher temperature which is conservative with respect to maximum rated temperature for equipment. Both specific volume and temperature are calculated with the Excel STMFUNC add-in [Ref. N6.2].

Table N5-1: Heat Balance Data – 0% Extraction

Parameter	Mass Flow W (lb _m /hr)	Pressure P _{DS} (psia)	Pressure P _{US} (psia)	Enthalpy h (Btu/lb _m)	Spec. Vol v _{DS} (ft ³ /lb _m)	Temp. T _{US} (°F)
HP Turbine to 1 st Stg. Rhtr	1.36E+05	448.7	451.0	1159.0	0.97	456.5
HP Turbine to 7th Stg. FWH	5.16E+05	408.7	451.0	1144.6	1.05	456.5
HP Turbine to 6th Stg. FWH	8.01E+05	287.1	296.5	1114.2	1.44	416.3
HP Turbine to 5th Stg. FWH	7.47E+05	186.1	190.3	1104.0	2.18	377.6
LP Turbine to 4th Stg. FWH	6.13E+05	89.6	92.4	1219.2	5.39	382.5
LP Turbine to 3rd Stg. FWH	5.96E+05	40.6	41.9	1158.8	10.2	270.1

Attachment N

Extraction Steam Evaluation – 50% Thermal Extraction

Parameter	Mass Flow W (lb _m /hr)	Pressure P _{DS} (psia)	Pressure P _{US} (psia)	Enthalpy h (Btu/lb _m)	Spec. Vol v _{DS} (ft ³ /lb _m)	Temp. T _{US} (°F)
LP Turbine to 2nd Stg. FWH	6.23E+05	15.9	16.4	976.3	20.4	217.7
LP Turbine to 1st Stg. FWH	6.63E+05	5.4	5.4	730.6	40.7	165.7

Table N5-2: Heat Balance Data – 50% Extraction

Parameter	Mass Flow W (lb _m /hr)	Pressure P _{DS} (psig)	Pressure P _{US} (psig)	Enthalpy h (Btu/lb _m)	Spec. Vol v _{DS} (ft ³ /lb _m)	Temp. T _{US} (°F)
HP Turbine to 1 st Stg. Rhtr	6.36E+04	257.1	258.4	1180.9	1.7	403.9
HP Turbine to 7th Stg. FWH	3.17E+05	229.2	258.4	1172.6	1.9	403.9
HP Turbine to 6th Stg. FWH	6.34E+05	161.3	166.6	1143.5	2.6	366.8
HP Turbine to 5th Stg. FWH	7.33E+05	102.3	104.6	1123.1	4.0	331.1
LP Turbine to 4th Stg. FWH	5.75E+05	46.9	48.3	1229.5	10.6	388.6
LP Turbine to 3rd Stg. FWH	5.69E+05	19.7	20.4	1162.8	20.8	241.5
LP Turbine to 2nd Stg. FWH	4.98E+05	7.3	7.6	1047.8	46.7	180.4
LP Turbine to 1st Stg. FWH	4.02E+05	2.4	2.4	845.6	105.3	133.5

Table N5-3: Heat Balance Data – 50% Extraction with Partial LP FWH Bypass

Parameter	Mass Flow W (lb _m /hr)	Pressure P _{DS} (psig)	Pressure P _{US} (psig)	Enthalpy h (Btu/lb _m)	Spec. Vol v _{DS} (ft ³ /lb _m)	Temp. T _{US} (°F)
HP Turbine to 1 st Stg. Rhtr	6.34E+04	256.2	257.5	1181.4	1.8	403.6
HP Turbine to 7th Stg. FWH	3.34E+05	224.5	257.5	1173.7	2.0	403.6
HP Turbine to 6th Stg. FWH	7.21E+05	157.5	162.7	1143.8	2.7	364.9
HP Turbine to 5th Stg. FWH	1.06E+06	95.5	97.6	1119.2	4.3	326.1
LP Turbine to 4th Stg. FWH	4.26E+05	44.8	46.2	1232.7	11.2	394.3
LP Turbine to 3rd Stg. FWH	4.26E+05	19.4	20.0	1167.4	21.4	250.5
LP Turbine to 2nd Stg. FWH	3.93E+05	7.3	7.6	1048.1	46.8	180.3
LP Turbine to 1st Stg. FWH	3.40E+05	2.5	2.5	827.1	101.5	134.0

N5.2 Expansion Joint Design Data

The input used to calculate the expansion joint required liner thickness is given below based on a typical plant configuration.

Table N5-4: Expansion Joint Design Data

Expansion Joint Location	Nom. Dia.	Liner ID	Liner Length
	[in.]	[in.]	[in.]
4 th Point Heater	14	11.75	9.63
3 rd Point Heater	18	15.75	9.75
2 nd Point Heater	28	25.25	9.75
1 st Point Heater	30	27.25	15.25

N5.3 Line Information

The extraction steam piping information used to calculate pressure drop for each line is given below based on a typical plant configuration.

Table N5-5: ES Line Information

	Piping Segment	Pipe ID (in)	Total K
HPT to 7th Stg FWH	Turb Extraction A	13.12	2.491
	Turb Extraction B	13.12	2.772
	Turb Extraction	18.81	3.945
	To Heater 7A	13.12	3.09
	To Heater 7B	13.12	3.342
HPT to 6th Stg FWH	Turb Extraction A	16.88	1.738
	Turb Extraction B	16.88	1.623
	Turb Extraction	22.62	4.204
	To Heater 6A	16.88	3.59
	To Heater 6B	16.88	3.814
HPT to 5th Stg FWH	Turb Extraction A	18.81	2.917
	Turb Extraction B	18.81	2.368
	Turb Extraction	29.00	4.043
	To Heater 5A	22.62	3.179
	To Heater 5B	22.62	3.63
LPT to 4th Stg FWH	Turb Extraction	13.00	2.467
	To Heater 4A	19.00	6.113
	Turb Extraction	13.00	2.467

Attachment N
Extraction Steam Evaluation – 50% Thermal Extraction

	Piping Segment	Pipe ID (in)	Total K
	To Heater 4B	19.00	5.683
	Turb Extraction	13.00	2.467
	To Heater 4C	19.00	6.141
LPT to 3rd Stg FWH	Turb Extraction	17.00	3.047
	Turb Extraction	23.00	3.518
	To Heater 3A	17.00	2.317
	Turb Extraction	17.00	3.098
	Turb Extraction	23.00	3.45
	To Heater 3B	17.00	2.339
	Turb Extraction	17.00	3.098
	Turb Extraction	23.00	3.5
	To Heater 3C	17.00	2.339
	LPT to 2nd Stg FWH	Turb Extraction	27.00
Turb Extraction		39.00	3.001
To Heater 2A		27.00	2.038
Turb Extraction		27.00	1.872
Turb Extraction		39.00	3.076
To Heater 2B		27.00	2.038
Turb Extraction		27.00	1.872
Turb Extraction		39.00	3.072
To Heater 2C		27.00	2.056
LPT to 1st Stg FWH	To Heater 1A	29.00	2.439
	To Heater 1A	29.00	2.116
	To Heater 1A	29.00	2.705
	To Heater 1A	29.00	2.345

N6.0 REFERENCES

- N6.1 Standards of the Expansion Joint Manufacturers Association (EJMA), Inc., Ninth Edition, 2008.
- N6.2 STMFUNC (Steam Table Function Dynamic Link Library) S&L Program Number 03.7.598 2.0, dated 06-11-2018.
- N6.3 Crane Technical Paper No. 410, *Flow of Fluids Through Valves, Fittings, and Pipe*, Twenty Fifth Printing, 1991.
- N6.4 Standards of the Expansion Joint Manufacturers Association (EJMA), Inc., Ninth Edition, 2008.

N7.0 EVALUATIONS**N7.1 Pressure Drop**

ES line pressure drops are compared for the baseline and 50% thermal extraction scenarios in Tables N7-1 and N7-2.

Table N7-1: ES Line Pressure Drop for 50% Thermal Extraction

	Upstream Pressure [psia]			Pressure Drop [psid]		
	0%	50%	Delta	0%	50%	Delta
HPT to 7th Stg FWH	451.0	258.4	-42.7%	6.50	4.53	-30.2%
HPT to 6th Stg FWH	296.5	166.6	-43.8%	8.46	9.76	15.3%
HPT to 5th Stg FWH	190.3	104.6	-45.0%	4.97	8.81	77.4%
LPT to 4th Stg FWH	92.39	48.34	-47.7%	4.33	7.49	73.0%
LPT to 3rd Stg FWH	41.9	20.36	-51.4%	3.24	6.02	85.6%
LPT to 2nd Stg FWH	16.43	7.581	-53.9%	0.78	1.15	46.7%
LPT to 1st Stg FWH	5.428	2.441	-55.0%	0.13	0.13	-4.8%

Table N7-2: ES Line Pressure Drop for 50% Thermal Extraction with Partial LP FWH Bypass

	Upstream Pressure [psia]			Pressure Drop [psid]		
	0%	50% w/ Bypass	Delta	0%	50% w/ Bypass	Delta
HPT to 7th Stg FWH	451.0	257.5	-42.9%	6.50	5.15	-20.7%
HPT to 6th Stg FWH	296.5	162.7	-45.1%	8.46	12.91	52.6%
HPT to 5th Stg FWH	190.3	97.6	-48.7%	4.97	19.67	295.9%
LPT to 4th Stg FWH	92.39	46.18	-50.1%	4.33	4.34	0.3%
LPT to 3rd Stg FWH	41.9	19.96	-52.4%	3.24	3.49	7.5%
LPT to 2nd Stg FWH	16.43	7.56	-54.0%	0.78	0.71	-8.5%
LPT to 1st Stg FWH	5.428	2.472	-54.5%	0.13	0.09	-34.4%

For the scenario with no LP FWH bypass, the pressure drop in the lines from the HPT to 7th stage FWHs and LPTs to 1st stage FWHs decreases, but all other extraction steam lines see an increase in pressure drop for the 50% thermal extraction case due to higher flow velocities. The most significant changes are in lines to the 3rd, 4th, and 5th stage FWHs which have an increase in pressure drop of greater than 70%.

With the addition of partial low pressure FWH bypass, the increased pressure drop at the 5th and 6th stage FWHs becomes significantly more pronounced. For the 5th stage heater specifically, the pressure drop is approximately 20% of the upstream pressure.

N7.2 Operating Conditions

ES line pressures and temperatures for the baseline and 50% thermal extraction scenarios are compared in Tables N7-3 and N7-4.

Table N7-3: ES Line Operating Conditions for 50% Thermal Extraction

	Line Pressure [psia]			Line Temperature [°F]		
	0%	50%	Delta	0%	50%	Delta
HPT to 1st Stg Rhtr	448.7	257.1	-42.7%	456.50	403.90	-52.6°F
HPT to 7th Stg FWH	408.7	229.2	-43.9%	456.50	403.90	-52.6°F
HPT to 6th Stg FWH	287.1	161.3	-43.8%	416.29	366.80	-49.5°F
HPT to 5th Stg FWH	186.1	102.3	-45.0%	377.64	331.06	-46.6°F
LPT to 4th Stg FWH	89.6	46.9	-47.7%	382.52	388.57	6.1°F
LPT to 3rd Stg FWH	40.6	19.7	-51.4%	270.06	241.47	-28.6°F
LPT to 2nd Stg FWH	15.9	7.3	-53.9%	217.68	180.42	-37.3°F
LPT to 1st Stg FWH	5.4	2.4	-55.0%	165.73	133.53	-32.2°F

Table N7-4: ES Line Operating Conditions for 50% Thermal Extraction with Partial LP FWH Bypass

	Line Pressure [psia]			Line Temperature [°F]		
	0%	50% w/ Bypass	Delta	0%	50% w/ Bypass	Delta
HPT to 1st Stg Rhtr	448.7	256.2	-42.9%	456.50	403.59	-52.9°F
HPT to 7th Stg FWH	408.7	224.5	-45.1%	456.50	403.59	-52.9°F
HPT to 6th Stg FWH	287.1	157.5	-45.1%	416.29	364.87	-51.4°F
HPT to 5th Stg FWH	186.1	95.5	-48.7%	377.64	326.09	-51.6°F
LPT to 4th Stg FWH	89.6	44.8	-50.0%	382.52	394.27	11.8°F
LPT to 3rd Stg FWH	40.6	19.4	-52.3%	270.06	250.51	-19.5°F
LPT to 2nd Stg FWH	15.9	7.3	-54.0%	217.68	180.30	-37.4°F
LPT to 1st Stg FWH	5.4	2.5	-54.5%	165.73	134.00	-31.7°F

Pressures and temperatures decrease for the thermal extraction cases in all lines other than a small temperature increase (~10°F) in the 4th Stg FWH line. Based on these results, margins for design pressures and temperatures will largely improve for relevant valves and expansion joints.

N7.3 Expansion Joint Required Liner Thickness

Required liner thicknesses for the baseline and 50% thermal extraction scenarios are compared in Tables N7-5 and N7-6.

Table N7-5: Expansion Joint Required Liner Thickness for 50% Thermal Extraction

	Required Liner Thickness [in]		
	0%	50%	Delta
LPT to 4th Stg FWH	0.137	0.186	35.7%
LPT to 3rd Stg FWH	0.138	0.193	39.4%
LPT to 2nd Stg FWH	0.156	0.211	35.4%
LPT to 1st Stg FWH	0.149	0.187	25.3%

Table N7-6: Required Liner Thickness for 50% Thermal Extraction with Partial LP FWH Bypass

	Required Liner Thickness [in]		
	0%	50% w/ Bypass	Delta
LPT to 4th Stg FWH	0.137	0.164	20.0%
LPT to 3rd Stg FWH	0.138	0.170	22.6%
LPT to 2nd Stg FWH	0.156	0.188	20.4%
LPT to 1st Stg FWH	0.149	0.169	13.1%

Liner thickness requirements increase for the thermal extraction cases. This increase is less pronounced for the partial LP FWH bypass scenario. Nevertheless, existing expansion joints will need to be evaluated on a plant-specific basis and may need to be replaced to ensure they meet these new requirements.

N8.0 RESULTS AND CONCLUSIONS

Analysis of the extraction steam system for the 50% thermal extraction scenario with no LP FWH bypass shows that overall, extraction steam line pressure drops increase due to higher flow velocities, with lines to the 3rd, 4th, and 5th stage feedwater heaters seeing an increase of over 70%. Under the partial LP FWH bypass scenario, the 5th and 6th stage feedwater heaters see increases of ~300% and ~50% respectively. Expansion joint liner thickness requirements also increase by up to 40% with no LP FWH bypass and 25% with partial LP FWH bypass. Existing expansion joints will need to be evaluated on a plant-specific basis and may need to be replaced to ensure they meet these new requirements.

Pressures and temperatures mostly decrease during operation with thermal extraction, so margins for design pressures and temperatures will largely improve for valves and expansion joints in the extraction steam system. The only exception is a slight temperature increase (~10°F) in the 4th Stage FWH extraction line. This slight increase is expected to be within the design margin of a typical plant.

Attachment O – Heater Drain System Assessment with 50% Thermal Energy Extracted

Prepared: Henry Fidlow / Nic Richards

Reviewed: Gabriel Neimark / Pawel Kut

Attachment O
Heater Drain System Assessment – 50% Thermal Extraction

O1.0 PURPOSE

The purpose of this appendix is to assess the heater drain system performance and expected changes to operating conditions due to operation with 50% turbine cycle thermal energy extracted from the main steam. This evaluation is performed for two scenarios: (1) 50% thermal energy extracted from main steam, and (2) 50% thermal energy extracted from main steam with 20% condensate flow bypass around the low-pressure feedwater heaters.

O2.0 SYSTEM & COMPONENT DESCRIPTION**O2.1 System Description**

There are seven stages of feedwater heating for normal operations. Two parallel trains ('A' and 'B' trains), each consisting of a feedwater heater (FWH) 5, 6 and 7, are available for normal operation. Drains cascade back to the heater drain tank (HDT) starting at FWH 7. Flow for each train passes through the FWH 5 external drain coolers before entering the HDT. Emergency drains to the condenser are available for FWHs 5, 6, and 7.

Three parallel FWH drain trains ('A' train, 'B' train, and 'C' train), each consisting of a FWH 1, 2, 3, and 4, are available for normal operation. Drains cascade from FWH 4 to the flash tanks through FWHs 3 and 2. FWHs 1 drain to the flash tanks as well. Each flash tank drains to the condenser via the FWH 1 external drain coolers. Emergency drains to the condenser are available for FWHs 4, 3, and 2, as well as the flash tanks.

Four MSR drain trains ('A' train, 'B' train, 'C' train, and 'D' train), each consisting of a moisture separator drain tank (MSDT), 1st stage reheater drain tank (RH1DT), and a 2nd stage reheater drain tank (RH2DT), are available for normal operation as well. The MSDT drains are directed to the HDT. The 1st and 2nd stage reheater drains are directed to FWHs 5 and 7, respectively. Emergency drain lines to the condenser are available for each of the drain lines.

O2.2 Component Description*a) Normal and Emergency Drain Control Valves*

The normal and emergency drain flow paths for each component are described below:

Table O2-1 – Component Flow Path Descriptions

Service	Source	Destination
7 th Point Normal	FWH 7	FWH 6
7 th Point Emergency	FWH 7	Condenser
6 th Point Normal	FWH 6	FWH 5
6 th Point Emergency	FWH 6	Condenser
5 th Point Normal	FWH 5	DC 5
5 th Point Emergency	FWH 5	Condenser
Drain Cooler 5 Normal	DC 5	HDT
Drain Cooler 5 Emergency	N/A	N/A

Attachment O
Heater Drain System Assessment – 50% Thermal Extraction

Service	Source	Destination
4 th Point Normal	FWH 4	FWH 3
4 th Point Emergency	FWH 4	Condenser
3rd Point Normal	FWH 3	FWH 2
3rd Point Emergency	FWH 3	Condenser
2nd Point Normal	FWH 2	Flash Tanks
2nd Point Emergency	FWH 2	Condenser
1st Point Normal	FWH 1	Flash Tanks
1st Point Emergency	N/A	N/A
Flash Tank Normal	Flash Tanks	DC 1
Flash Tank Emergency	Flash Tanks	Condenser
Drain Coolers 1 Normal	DC 1	Condenser
Drain Coolers 1 Emergency	N/A	N/A
HDT Normal	FWH Drain Tank	Condensate Booster System
HDT Emergency	FWH Drain Tank	Condenser
RH2DT Normal	2 nd Stage Drain Tanks	FWH 7
RH2DT Emergency	2 nd Stage Drain Tanks	Condenser
RH1DT Normal	1 st Stage Drain Tanks	FWH 5
RH1DT Emergency	1 st Stage Drain Tanks	Condenser
MSDT Normal	MSR Shell Drain Tanks	HDT
MSDT Emergency	MSR Shell Drain Tanks	Condenser

b) Drain Tanks

Drain tanks are provided to collect condensed steam from the moisture separators, 1st and 2nd stage reheaters, and feedwater heaters. The drain tanks in the HD system include:

- i) Heater Drain Tank
- ii) Moisture Separator Drain Tanks
- iii) 1st Stage Reheater Drain Tanks
- iv) 2nd Stage Reheater Drain Tanks
- v) Flash Tanks

c) Heater Drain Pumps

The HDPs function to pump drains collected in the HDT forward to the condensate system through control valves. There are three 50% capacity HDPs. Normally two pumps operate with a third in standby. These pumps and control valves are evaluated in the Power Train Pumps Assessment (see Attachment K)

Attachment O
Heater Drain System Assessment – 50% Thermal Extraction

O3.0 METHODOLOGY**O3.1 Required Drain Control Valve (DCV) Capacity**

The flow capacity (C_v) of a control valve is a function of the valve body, valve trim, valve stem position, fluid properties of inlet liquid, and downstream backpressure. The methodology for evaluating the capacity is the standard industry method as outlined in the Masoneilan Control Valve Sizing Handbook [Ref. O6.1]. For the evaluations here, the required duty (in lb_m/hr) is taken from the heat balances (see Design Input O5.1). The C_v required of the valve is then determined and the required valve flow coefficient during 50% thermal power extraction operating conditions is compared against the baseline valve C_v to determine the impact operating with thermal power extraction has on the level control valves.

The steps in the determination are as follows:

- Determine the required mass flow rate (see Design Input O5.1 for inputs used).
- Determine the valve inlet water temperature and pressure (see Design Input O5.1 for inputs used).
- Determine valve inlet pressure (see Section O3.1.1).
- Determine the pressure differential at which the valve chokes. This is termed the ‘allowable pressure differential’ as any further decrease in downstream pressure (increase in valve pressure differential) will not increase the mass flow rate through the valve. Required input for this includes the pressure recovery factor (F_L), the inlet pressure (P_1), the critical pressure ratio factor (F_F), and the saturation vapor pressure at the valve inlet (P_v).
- Determine the valve outlet pressure if no choking occurs (see Section O3.1.3) to determine valve pressure drop without choking (valve inlet pressure minus valve outlet pressure).
- Set the ‘available pressure drop’ across the valve equal to the smaller of the two pressure drops from above.
- Determine the required C_v based on the volumetric flow rate, the entering fluid specific gravity, and the available pressure drop.
- Compare the required C_v to the VWO C_v .

O3.1.1 Valve Inlet Pressure

The inlet pressure to the control valve is calculated based on the upstream heater shell side pressure. Elevation head between the operating level in the heater and the centerline elevation of the valve is then added/subtracted from this pressure. Next, the pressure drop through the drain cooler or upstream FWH is subtracted, if applicable. Pressure loss in the piping between the upstream heater and the valve is computed using Crane [Ref. O6.2]. These pressure differentials are based on generic plant input.

Attachment O
Heater Drain System Assessment – 50% Thermal Extraction

O3.1.2 Allowable Pressure Drop

The allowable pressure drop is based on the choked pressure drop of the valve and is defined as follows [Ref. O6.1]:

$$\Delta P_{ch} = F_L^2 (P_1 - F_F P_V) \quad \text{Eq. O3-1}$$

where:

ΔP_{ch}	Pressure differential at which the flow chokes [psid]
F_L	Pressure recovery factor (see Assumption O4.1)
P_1	Valve inlet pressure [psia]
F_F	Critical pressure ratio factor (see Equation O3-3)
P_V	Vapor pressure of water at inlet temperature [psia]

and

$$F_F = 0.96 - 0.28 \sqrt{P_V / P_C} \quad \text{Eq. O3-2}$$

where:

F_F	Critical pressure ratio
P_V	Valve inlet vapor pressure [psia]
P_C	Critical pressure of water, 3206 psia [Ref. O6.1]

O3.1.3 Pressure Drop Based on Friction Flow in the Downstream Piping

In addition to the allowable pressure drop based on the valve characteristics, there is also an available pressure drop across the valve based on frictional pressure drop and elevation changes in the downstream piping. These pressure differentials are based on generic plant input. The resulting outlet pressure is then subtracted from the inlet pressure (see Section O3.1.1), giving an available pressure drop across the valve.

O3.1.4 Control Valve Liquid Flow Coefficient C_V

Control valve C_V is defined as [Ref. O6.1]:

$$C_V = \frac{q}{F_P \sqrt{\Delta P_a}} \sqrt{\frac{G_F}{\Delta P_a}} \quad \text{Eq. O3-3}$$

where:

C_V	Valve flow sizing coefficient
q	Flow rate [gpm]
F_P	Piping geometry factor
ΔP_a	Allowable pressure drop across the valve [psid]
G_f	Specific gravity of fluid

Attachment O
Heater Drain System Assessment – 50% Thermal Extraction

In the expression above, q and G_f are based on the entering fluid volumetric flow rate, pressure and temperature. The pressure drop is taken as the minimum of (i) the allowable pressure drop based on choked flow considerations and of (ii) the available pressure drop from frictional and elevation head pressure drop evaluations. Pipe fittings are accounted for in the generic pipe plant losses so the piping geometry factor is not used.

O3.2 Tank Parameters

Operating parameters of the system tanks are reviewed to evaluate the impact of operating with thermal power extraction.

O4.0 ASSUMPTIONS

O4.1 Valve Pressure Recovery Factor (F_L)

A generic pressure recovery factor of $F_L = 0.85$ is used based on typical industry values.

O5.0 DESIGN INPUTS

O5.1 FWH Drain Baseline and 50% Thermal Extraction Conditions

Drain flows, pressures, and temperatures are taken from Attachment A and averaged across the available strings. The average values for the baseline and 50% Thermal Extraction cases are presented in Table O5-1 below.

Table O5-1 – Average FWH Drain Conditions

Parameter	Units	Baseline (0% Extraction)	50% Extraction	50% Extraction w/ Bypass
MSDT Drain Flow	lbm/hr	331,167	116,108	112,625
MSDT Drain Pressure	psia	184.6	101.4	94.7
MSDT Drain Temperature	°F	375.1	328.8	323.9
RH1DT Drain Flow	lbm/hr	135,811	63,649	63,355
RH1DT Drain Pressure	psia	444.2	254.6	253.7
RH1DT Drain Temperature	°F	455.0	402.6	402.3
RH2DT Drain Flow	lbm/hr	200,488	172,593	162,685
RH2DT Drain Pressure	psia	864.2	870.5	872.5
RH2DT Drain Temperature	°F	527.2	528.0	528.3
FWH 3 LPT to Pressure	psia	40.6	19.7	19.4
FWH 4 LPT to Flow	lbm/hr	202,252	189,886	141,146
FWH 4 LPT to Pressure	psia	89.5	46.8	44.8
FWH 1 Extraction Pressure	psia	5.42	2.43	2.47
FWH 1 Drain Temp	°F	165.2	132.6	133.4
FWH 2 Extraction Pressure	psia	15.9	7.3	7.3
FWH 2 Drain Temp	°F	169.9	135.7	135.3
FWH 3 Extraction Pressure	psia	40.6	19.7	19.4

Attachment O
Heater Drain System Assessment – 50% Thermal Extraction

Parameter	Units	Baseline (0% Extraction)	50% Extraction	50% Extraction w/ Bypass
FWH 3 Drain Temp	°F	225.4	184.8	183.2
FWH 4 Extraction Pressure	psia	89.5	46.8	44.8
FWH 4 Drain Temp	°F	275.5	232.5	230.0
FWH 5 Extraction Pressure	psia	186.1	102.3	95.5
FWH 5 Drain Temp	°F	375.8	329.4	324.3
FWH 6 Extraction Pressure	psia	287.1	161.3	157.5
FWH 6 Drain Temp	°F	374.9	326.4	319.1
FWH 7 Extraction Pressure	psia	408.7	229.2	224.5
FWH 7 Drain Temp	°F	421.0	368.7	366.0
FWH 7 Drain Flow	lbm/hr	658,822	503,655	492,530
FWH 6 Drain Flow	lbm/hr	1,059,170	820,706	852,880
DC 5 Drain Flow	lbm/hr	1,704,062	1,314,288	1,510,036
FWH 4 Drain Flow	lbm/hr	202,252	189,886	141,146
FWH 3 Drain Flow	lbm/hr	398,540	378,554	282,253
FWH 2 Drain Flow	lbm/hr	601,704	540,461	410,700
DC 1 Drain Flow	lbm/hr	821,877	674,238	523,929
Condenser Shell Pressure	psia	1.42	0.92	0.93

O6.0 REFERENCES

- O6.1 BHMN-Valve-Sizing-Handbook-TS-19540C-0222, "Masoneilan Control Valve Sizing Handbook," Baker Hughes, 02/2022
- O6.2 Flow of Fluids Through Valve, Fittings, and Pipe, Crane Technical Paper No. 410, 1991
- O6.3 STMFUNC, "Steam Table Function Dynamic Link Library," S&L Program Number 03.7.598-2.0

Attachment O
Heater Drain System Assessment – 50% Thermal Extraction

O7.0 EVALUATIONS**O7.1 Valve Flow Capacity****O7.1.1 *Valve Flow***

Valve volumetric flow is computed based on the mass flow rate and fluid temperature. The liquid density is computed using Excel add-on STMFUNC [Ref. O6.3]. Table O7-1 provides a comparison of the volumetric mass flow rates.

Table O7-1 – Drain Volumetric Flow Comparison

Description	Baseline [gpm]	50% Extraction		50% Extraction w/ Bypass	
		Flow Rate [gpm]	Percent Change [-]	Flow Rate [gpm]	Percent Change [-]
Flash Tank Normal	1,683	1,367	-18.8%	1,062	-36.9%
FWH 2 Normal	1,234	1,096	-11.2%	833	-32.5%
FWH 3 Normal	836	781	-6.6%	582	-30.4%
FWH 4 Normal	434	399	-8.1%	297	-31.7%
FWH 6 Normal	2,416	1,814	-24.9%	1,876	-22.3%
FWH 7 Normal	1,557	1,144	-26.5%	1,117	-28.3%
MSDT Normal	756	257	-66.0%	248	-67.1%
RHDT1 Normal	331	148	-55.2%	147	-55.4%
RHDT2 Normal	527	455	-13.8%	429	-18.7%
Flash Tank Emergency	1,683	1,367	-18.8%	1,062	-36.9%
FWH 2 Emergency	1,234	1,096	-11.2%	833	-32.5%
FWH 3 Emergency	836	781	-6.6%	291	-65.2%
FWH 4 Emergency	434	399	-8.1%	297	-31.7%
FWH 5 Emergency	3,890	2,910	-25.2%	3,333	-14.3%
FWH 6 Emergency	2,416	1,814	-24.9%	1,876	-22.3%
FWH 7 Emergency	1,557	1,144	-26.5%	1,117	-28.3%
MSDT Emergency	756	257	-66.0%	248	-67.1%
RHDT1 Emergency	331	148	-55.2%	147	-55.4%
RHDT2 Emergency	527	455	-13.8%	429	-18.7%

As shown in Table O7-1, drain flows decrease between 6% and 67% when 50% thermal power is extracted. The drain flow decrease on the low-pressure feedwater heaters is greater under the bypass scenario compared to no bypass at 50% thermal extraction.

Attachment O
Heater Drain System Assessment – 50% Thermal Extraction

07.1.2 Valve Pressure Drop

The pressure drop across the valve is the minimum of the allowable pressure drop due to choked flow (see Section O3.1.2) and the available pressure drop from valve inlet to outlet based on flow conditions and frictional losses (see Section O3.1.3). Tables O7-2 and O7-3 provide the computed pressure losses for each thermal extraction scenario. The minimum pressure loss for each valve is shown in **bold** text.

Table O7-2 – Drain Valve Pressure Loss for 50% Thermal Extraction

Description	Baseline (0% Extraction)		50% Extraction		Percent Change	
	Choked dP [psid]	Available dP [psid]	Choked dP [psid]	Available dP [psid]	Choked dP [-]	Available dP [-]
Flash Tank Normal	2.7	7.3	3.1	5.6	16.0%	-23.4%
FWH 2 Normal	2.3	3.2	-0.6	-1.1	-126.3%	-134.0%
FWH 3 Normal	9.1	14.6	1.7	2.9	-81.2%	-79.8%
FWH 4 Normal	32.1	44.5	17.4	23.4	-45.6%	-47.4%
FWH 6 Normal	85.0	95.9	48.8	54.5	-42.6%	-43.1%
FWH 7 Normal	90.9	108.1	47.8	54.7	-47.4%	-49.4%
MSDT Normal	19.6	5.9	12.2	7.0	-37.8%	18.4%
RHDT1 Normal	42.7	249.3	19.0	145.3	-55.5%	-41.7%
RHDT2 Normal	115.6	454.6	117.0	641.0	1.3%	41.0%
Flash Tank Emergency	4.1	9.2	4.0	6.9	-1.0%	-25.3%
FWH 2 Emergency	5.5	11.7	2.6	5.0	-52.7%	-57.2%
FWH 3 Emergency	15.0	37.1	7.8	17.6	-48.3%	-52.6%
FWH 4 Emergency	38.4	92.0	24.0	50.8	-37.6%	-44.8%
FWH 5 Emergency	23.0	196.4	15.7	113.7	-31.7%	-42.1%
FWH 6 Emergency	86.9	283.3	50.8	158.7	-41.6%	-44.0%
FWH 7 Emergency	97.5	405.9	54.6	227.5	-44.0%	-44.0%
MSDT Emergency	16.4	186.0	8.8	103.5	-46.4%	-44.3%
RHDT1 Emergency	47.6	444.7	23.7	256.2	-50.2%	-42.4%
RHDT2 Emergency	116.8	862.6	118.5	870.8	1.5%	1.0%

Table O7-3 – Drain Valve Pressure Loss for 50% Thermal Extraction with Bypass

Description	Baseline (0% Extraction)		50% Extraction w/ Bypass		Percent Change	
	Choked dP [psid]	Available dP [psid]	Choked dP [psid]	Available dP [psid]	Choked dP [-]	Available dP [-]
Flash Tank Normal	2.7	7.3	3.5	6.2	31.2%	-14.8%
FWH 2 Normal	2.3	3.2	1.0	1.2	-57.5%	-62.3%
FWH 3 Normal	9.1	14.6	3.8	5.5	-58.6%	-62.1%
FWH 4 Normal	32.1	44.5	17.7	23.9	-44.9%	-46.1%

Attachment O
Heater Drain System Assessment – 50% Thermal Extraction

Description	Baseline (0% Extraction)		50% Extraction w/ Bypass		Percent Change	
	Choked dP [psid]	Available dP [psid]	Choked dP [psid]	Available dP [psid]	Choked dP [-]	Available dP [-]
FWH 6 Normal	85.0	95.9	52.1	57.4	-38.7%	-40.2%
FWH 7 Normal	90.9	108.1	47.9	53.9	-47.3%	-50.1%
MSDT Normal	19.6	5.9	11.7	7.0	-40.5%	19.8%
RHDT1 Normal	42.7	249.3	18.9	151.2	-55.7%	-39.4%
RHDT2 Normal	115.6	454.6	117.5	647.9	1.7%	42.5%
Flash Tank Emergency	4.1	9.2	4.1	7.0	-0.4%	-24.2%
FWH 2 Emergency	5.5	11.7	4.3	7.3	-22.5%	-37.3%
FWH 3 Emergency	15.0	37.1	9.9	20.3	-34.0%	-45.2%
FWH 4 Emergency	38.4	92.0	24.3	51.2	-36.7%	-44.4%
FWH 5 Emergency	23.0	196.4	15.2	106.9	-34.0%	-45.6%
FWH 6 Emergency	86.9	283.3	54.1	154.7	-37.8%	-45.4%
FWH 7 Emergency	97.5	405.9	54.8	222.8	-43.8%	-45.1%
MSDT Emergency	16.4	186.0	8.2	96.8	-49.7%	-47.9%
RHDT1 Emergency	47.6	444.7	23.6	255.3	-50.4%	-42.6%
RHDT2 Emergency	116.8	862.6	119.1	873.3	2.0%	1.2%

As shown in Table O7-2, all drain control valves experience choked flow conditions except for the moisture separator drain tank and FWH 2 under normal operating conditions. The FWH 2 normal drain control valve exhibits excessive inlet and outlet pressure drop resulting in a negative pressure loss, which is not possible. Adjustments to the plant operation (opening of the emergency dump valve or opening of the LP FWH bypass) would be required in order to maintain normal operation under 50% thermal extraction. With respect to valve capacity, a decrease in valve pressure loss is non-conservative, as the pressure loss is in the denominator (see Equation O3-3). Therefore, nearly all valves see a non-conservative reduction in allowable pressure loss, with the exception of the flash tank normal drain valves, moisture separator drain tank normal drain valves, and 2nd stage reheater drain tank emergency and normal drain valves. In most cases, the reduction in allowable pressure drop is significant. The resulting impact on required C_v is discussed in Section O7.1.3.

To address the negative pressure loss issue faced by FWH 2 normal DCV, the low-pressure FWH bypass scenario is developed, using 20% condensate flow bypass. Under this scenario, it is observed that the drain control valve experiences choked flow with a pressure drop of 1 psi. Similar to the no bypass scenario, a majority of the valves experience a non-conservative reduction in allowable pressure loss. However, the exceptions for the bypass scenario are the flash tank normal drain valves, moisture separator drain tank normal drain valves, and 2nd stage reheater drain tank normal and emergency drain control valves.

Attachment O
Heater Drain System Assessment – 50% Thermal Extraction

07.1.3 Required Valve C_v

The resulting required valve C_v values are presented in Table O7-4. Increases in C_v are shown in **bold** text.

Table O7-4 – Drain Valve Required C_v Capacity

Description	Baseline (0% Extraction) [-]	50% Extraction		50% Extraction w/ Bypass	
		C_v [-]	Percent Change [-]	C_v [-]	Percent Change [-]
Flash Tank Normal	1019	772	-24.2%	565	-44.6%
FWH 2 Normal	796	N/A	N/A	829	4.2%
FWH 3 Normal	271	588	117.2%	295	9.1%
FWH 4 Normal	74	93	26.0%	69	-7.0%
FWH 6 Normal	245	247	0.7%	248	1.0%
FWH 7 Normal	150	155	3.4%	151	0.9%
MSDT Normal	292	93	-68.3%	89	-69.4%
RHDT1 Normal	46	31	-31.3%	31	-31.5%
RHDT2 Normal	43	37	-14.4%	34	-19.5%
Flash Tank Emergency	823	675	-18.0%	523	-36.4%
FWH 2 Emergency	520	675	29.8%	401	-22.9%
FWH 3 Emergency	211	276	31.0%	182	-13.6%
FWH 4 Emergency	68	79	17.6%	59	-13.2%
FWH 5 Emergency	759	698	-8.1%	814	7.3%
FWH 6 Emergency	243	242	-0.2%	243	0.3%
FWH 7 Emergency	145	145	0.1%	142	-2.3%
MSDT Emergency	175	82	-52.8%	82	-52.8%
RHDT1 Emergency	43	28	-35.1%	28	-35.2%
RHDT2 Emergency	43	36	-14.5%	34	-19.6%

As shown in Table O7-4, the required C_v capacity for the low-pressure FWHs increases significantly with 50% thermal power extraction and no bypass. FWHs 6 and 7 exhibit required increases of less than 5%, which is typically within the operating margin of a well sized drain control valve. Therefore, no equipment changes would be expected for these FWH DCVs, but a station specific review is required. FWH 4 normal and emergency DCVs require an increased C_v capacity of 26% and 18%, respectively, and would require station specific review for valve acceptability. FWH 3 normal and emergency DCVs shows significantly increased flow capacity requirements, and would likely both need to be replaced, along with the FWH 2 emergency DCV. For the reference plant, the FWH 2 normal DCV cannot meet the flow capacity requirements of 50% thermal extraction and would require operational and/or design changes in order to satisfy system requirements. This would need to be determined based on the plant specific evaluation. The FWH 5 emergency DCV as well as the flash tank and the various MSR drain tank DCVs all see reduced capacity requirements.

Attachment O
Heater Drain System Assessment – 50% Thermal Extraction

To address the flow capacity issue on the FWH 2 normal DCV, the 20% condensate flow bypass scenario is developed. With this operational change nearly all FWH DCVs experience a reduction in required C_v . The only valves expected to potentially require valve/trim replacement would be the FWH 2 and 3 normal DCVs, which experience required C_v increases of 4% and 9% respectively. The FWH 5 emergency DCV required C_v increase by ~7%, but emergency DCVs typically have sufficient margin to accommodate an increase of this magnitude. Station specific review would be required to determine if these valves/trims need to be replaced.

07.2 Drain Tank Parameters

The operating parameters for the drain tanks (MSDT, RH1DT, RH2DT, & Flash Tank) are reviewed for the 50% thermal extraction scenarios in Tables O7-5 and O7-6.

Table O7-5 – Drain Tank Conditions for 50% Thermal Extraction

Parameter	Units	Baseline (0% Extraction)	50% Thermal Extraction	Percent Change [-]
MSDT Drain Flow	<i>lbm/hr</i>	331,167	116,108	-64.9%
RH1DT Drain Flow	<i>lbm/hr</i>	135,811	63,649	-53.1%
RH2DT Drain Flow	<i>lbm/hr</i>	200,488	172,593	-13.9%
Flash Tank Drain Flow	<i>lbm/hr</i>	821,877	674,238	-18.0%
MSDT Drain Pressure	<i>psia</i>	184.6	101.4	-45.0%
RH1DT Drain Pressure	<i>psia</i>	444.2	254.6	-42.7%
RH2DT Drain Pressure	<i>psia</i>	864.2	870.5	0.7%
Flash Tank Drain Pressure	<i>psia</i>	5.42	2.43	-55.1%
MSDT Drain Temperature	$^{\circ}\text{F}$	375.1	328.8	-46.3 $^{\circ}\text{F}$
RH1DT Drain Temperature	$^{\circ}\text{F}$	455.0	402.6	-52.4 $^{\circ}\text{F}$
RH2DT Drain Temperature	$^{\circ}\text{F}$	527.2	528.0	0.9 $^{\circ}\text{F}$
Flash Tank Drain Temperature	$^{\circ}\text{F}$	165.2	132.6	-32.6 $^{\circ}\text{F}$

Table O7-6 – Drain Tank Conditions for 50% Thermal Extraction with Bypass

Parameter	Units	Baseline (0% Extraction)	50% Thermal Extraction w/ Bypass	Percent Change [-]
MSDT Drain Flow	<i>lbm/hr</i>	331,167	112,625	-66.0%
RH1DT Drain Flow	<i>lbm/hr</i>	135,811	63,355	-53.4%
RH2DT Drain Flow	<i>lbm/hr</i>	200,488	162,685	-18.9%
Flash Tank Drain Flow	<i>lbm/hr</i>	821,877	523,929	-36.3%
MSDT Drain Pressure	<i>psia</i>	184.6	94.7	-48.7%
RH1DT Drain Pressure	<i>psia</i>	444.2	253.7	-42.9%
RH2DT Drain Pressure	<i>psia</i>	864.2	872.5	1.0%
Flash Tank Drain Pressure	<i>psia</i>	5.42	2.47	-54.5%
MSDT Drain Temperature	$^{\circ}\text{F}$	375.1	323.9	-13.7%
RH1DT Drain Temperature	$^{\circ}\text{F}$	455.0	402.3	-11.6%

Attachment O
Heater Drain System Assessment – 50% Thermal Extraction

Parameter	Units	Baseline (0% Extraction)	50% Thermal Extraction w/ Bypass	Percent Change [-]
RH2DT Drain Temperature	°F	527.2	528.3	0.2%
Flash Tank Drain Temperature	°F	165.2	133.4	-19.2%

As shown in Tables O7-5 and O7-6, mass flow rates decrease for all drain tanks. Pressure and temperatures also decrease for all tanks except the 2nd stage reheater drain tank. Conditions for RH2DT show minimal change. As all parameters either decrease or show minimal change, the heater drain system drain tanks are expected to operate normally during thermal power extraction operation, with or without bypass.

O8.0 RESULTS AND CONCLUSIONS

The required C_v capacity is reduced for the FWH 5, flash tank, and the various MSR drain tanks DCVs when operating with 50% thermal power extraction. With no bypass, the DCVs for a majority of the feedwater heaters would require greater flow passing capability. FWHs 6 and 7 exhibit required increases of less than 5%, therefore no equipment changes are expected. FWH 4 requirements increase by 26% and will require station specific review to determine if valve replacement is necessary. FWHs 2 and 3 show significant increase in required flow capacity; therefore, it is expected that a station specific review of these FWHs would require valve/trim replacement prior to operation with thermal power extracted.

By modifying plant operation by allowing for 20% condensate flow bypass around the low-pressure feedwater heaters, the increase in required flow capacity for the feedwater heaters is significantly reduced. Through this change, the FWH 2 and 3 normal DCVs and FWH 5 emergency DCV experience increases in required C_v of <10% and should be evaluated to determine if replacement would be needed on a site-specific basis. All other DCVs should experience a decrease in C_v or negligible (<1%) increase, and are not expected to require replacement. However, this may require modification to the LP FWH bypass valve to allow for specified flow control.

Operating parameters for all heater drain system drain tanks either decrease or show minimal change and are expected to operate normally during 50% thermal power extraction with or without bypass.

Attachment P – Feedwater Heater Evaluation with 70% Thermal Energy Extracted

Prepared: Gabriel Neimark

Reviewed: Nic Richards

P1.0 PURPOSE

The purpose of this evaluation is to examine required duty and expected changes to operating conditions and performance parameters in relation to the design of the Feedwater Heaters. These changes are due to extracting steam from the nuclear power cycle main steam system to supply thermal energy to the plant boundary for off-site use. This evaluation is performed for the scenario where 70% thermal energy is extracted from main steam.

P2.0 SYSTEM & COMPONENT DESCRIPTION

The Condensate (CD) and Feedwater (FW) Systems deliver feedwater (condensed steam) to the steam generators. The CD system first directs flow through three parallel strings of low pressure feedwater heaters (1st point external drain cooler and 1st through 4th point heaters). Flow then passes through two parallel strings of low pressure feedwater heaters (5th point external drain cooler, 5th and 6th point heaters) to the turbine driven steam generator feed pumps (SGFP). FW flow then continues through two parallel high pressure feedwater heaters (7th point heaters) to the steam generators. The feedwater heaters receive extraction steam flow and moisture separator reheater drain flow from the main turbine system.

P3.0 METHODOLOGY AND ACCEPTANCE CRITERIA**P3.1 Methodology****P3.1.1 Tube Side Nozzle Velocity**

The water velocity in these nozzles must be limited to minimize metal erosion in the head and tube sheet areas caused by feedwater impingement. The velocity used with the HEI guidelines [Ref. P6.2] is based on the density of liquid water at 60°F.

P3.1.2 Tube Velocity

In order to avoid excessive tube erosion, the tube velocity should be limited. The flow area is based on the total number of tubes for each pass minus the number of plugged tubes. In accordance with HEI guidelines [Ref. P6.2], the density used in computing the tube velocity is based on the density of liquid water at the average tube temperature.

P3.1.3 Tube Side Pressure Drop and Partition Plate Differential Pressure

The tube side pressure drop principally affects two design issues, (i) the differential pressure across the pass partition plate (PPP), and (ii) the total pressure drop in the feedwater train. The pass partition plate is integral to the head of the feedwater heater, and separates the fluid entering the first tube pass from the fluid exiting the second tube pass. Moderately high differential pressures across the PPP can cause cracking of the welds in the plate or displacement of the partition gasket, which results in leakage and reduced heater performance. No guidelines are stated in HEI for the differential pressure across the PPP.

HEI [Ref. P6.2] provides an approximate method of calculating total tube side pressure drop, which consists of the sum of the following terms (see definitions below):

$$\Delta P_{total} = \Delta P_{tubes} + \Delta P_{NI} + \Delta P_{NO} + \Delta P_E \quad (Eq. P3-1)$$

where:

- ΔP_{total} -total tube side pressure drop, psid
- ΔP_{tubes} -pressure loss through tubes, psid
- ΔP_{NI} -pressure loss through channel inlet nozzle, psid
- ΔP_{NO} -pressure loss through channel outlet nozzle, psid
- ΔP_E -tube entrance, exit, and turning losses, psid

Pressure loss across inlet channel and outlet nozzle do not impact the pressure loss across the pass partition plate. Therefore, only the pressure loss through the tubes and the tube entrance, exit, and turning losses impact the PPP pressure drop.

These pressure drops are defined as follows from the HEI standards [Ref. P6.2]:

ΔP Inside Tubes

$$\Delta P_{tubes} = \frac{1.396 \times 10^{-7}}{C} \cdot f \cdot \left(\frac{w}{A_t} \right)^2 \cdot \frac{L}{d} \quad (Eq. P3-2)$$

where:

$$f = 0.0014 + 0.125 \cdot Re^{-0.32}$$

$$Re = \frac{w \cdot d}{0.201389 \cdot \mu \cdot A_t}$$

Tube Entrance, Exit, and Turn Losses

$$\Delta P_E = \frac{2.896 \times 10^{-9}}{C} \cdot K_t \cdot \left(\frac{w}{A_t} \right)^2 \cdot \frac{N}{2} \quad (Eq. P3-3)$$

where:

- w - feedwater mass flow rate, lb_m/hr
- L - total length of tube travel, ft
- A_t - flow area of tubes per pass accounting for tube plugging, in²
- d - nominal inside diameter of tubes, in
- C - density correction factor from Fig. 3a [Ref. P6.2]
- f - friction factor
- K_t - loss correction factor for tube configuration from Fig. 3b [Ref. P6.2]
- N - number of tube passes
- Re - Reynolds number for individual tube at calculated flow rate per tube
- μ - tube side absolute viscosity, centipoise

Review of Equations P3-2 and P3-3 show most factors are based on the physical design of the FWH and are not sensitive to changes in operating conditions. The density correction factor and friction factor are slightly impacted, but over the range of operating conditions expected, the impact is inconsequential compared to the change in feedwater mass flow rate (which is a squared term). Therefore, to review the impact on PPP pressure loss, only the change in mass flow rate squared is reviewed.

P3.1.4 Steam Inlet and Drain Outlet Nozzle Velocity

Steam velocities entering the shell side of the heater must be limited in order to prevent overstressing of the impingement plate, erosion damage (i.e., to the impingement plate, tube support plates, and heater shell) and to control vibration of the tubes in the high velocity regions where steam is introduced to the tube bundle. Steam velocity is based on the fluid conditions from the heat balance, and it is compared against the recommended limit from the HEI standard [Ref. P6.2].

The steam velocity entering the heater is the mass flow rate of steam entering the heater from the heat balance, divided by the density of the steam, divided by the flow area of a single steam inlet nozzle, divided by the number of steam inlet nozzles per heater.

The velocity in the condensate drain outlet nozzle is calculated as the mass flow rate from the heat balance, divided by the density of liquid discharging from the heater, divided by the flow area of the drain nozzle.

P3.1.5 Drain Inlet Nozzle Mass Flux

The limits for this parameter are provided to minimize and/or avoid the following:

- erosion of the inlet nozzle and heater shell areas adjacent to the nozzle,
- structural damage to the impingement plate and adjacent tube support plates,
- tube degradation in the areas adjacent to the impingement plate, and
- vibration of tubes in high velocity regions where the two-phase mixture is introduced to the tube bundle.

HEI characterizes the inlet conditions through the use of a mass flux parameter, which is equal to the square of the mass flux rate divided by the fluid inlet density. The density is evaluated using the inlet enthalpy and heater shell pressure from the heat balance.

P3.1.6 Operating Pressure and Temperature

Tube side and shell side operating temperatures and shell side pressures for the baseline and 70% thermal extraction cases are compared to determine the impact on design value margin. These parameters are taken from the heat balances in Attachment A.

P3.1.7 Drain Cooler Tube Vibration

The main sources of vibration in drain coolers are vortex shedding and fluidelastic whirling [Ref. P6.3]. In order to prevent resonant tube vibration from vortex shedding, the natural frequency of the unsupported tube span should remain larger than the vortex shedding frequency. TEMA requires that the natural frequency exceed the vortex shedding frequency. The natural frequency of the tube span is dependent on the physical design of the FWH and is therefore not impacted by changes to operating conditions associated with operating with thermal power extraction. The vortex shedding frequency is proportional to the cross flow velocity at the tubes. Since the cross flow area will not change with thermal power extraction, the total volumetric drain cooler flow is reviewed for changes due to operation with 70% thermal energy extraction.

Another possible mechanism for vibrational damage is fluidelastic whirling. This process occurs when the displacement of one tube alters the flow field resulting in forces on other tubes. If the exciting force from the flowing fluid exceeds damping, the self-excited vibration will set up. In order to prevent this excitation, the critical whirling velocity must exceed the cross flow velocity. The critical velocity is calculated using the methodology of TEMA [pages 94 & 95, Ref. P6.3].

A review of the TEMA equations shows that the critical velocity is based on physical parameters with a minor relationship to density. As the density is not significantly changing in the drain cooler due to operation with thermal power extraction, critical velocity can be considered constant for the purposes of this evaluation. Therefore, as with vortex shedding, only the cross flow velocity will be impacted by reviewing the total volumetric drain cooler flow changes due to operation with 70% thermal energy extraction.

P3.2 **Acceptance Criteria**

P3.2.1 Acceptance Criterion 1 – Tube side nozzle velocity should be less than 10 ft/s, according to HEI [Ref. P6.2].

P3.2.2 Acceptance Criterion 2 – Tube velocity should be less than 10 ft/s, according to HEI [Ref. P6.2].

P3.2.3 Acceptance Criterion 3 – Steam inlet nozzle velocity should be less than the HEI recommendation:

$$V \leq \frac{250}{P_{STEAM}^{0.09}} \quad (Eq. P3-4)$$

P3.2.4 Acceptance Criterion 4 – Condensate drain outlet velocity should be less than the HEI recommendation [Ref. P6.2] as follows:

- 4 ft/sec for sub-cooled drains,
- 4 ft/sec for saturated drains with level control in the heater, and
- 2 ft/sec for saturated drains where the level is not controlled in the heater

Velocity in the heater drain outlet nozzle must be limited to (a) avoid excessive drag loads on drain cooler tubes in the vicinity of the nozzle, and (b) prevent flashing in the downstream piping connected to the heater outlet nozzle.

P3.2.5 Acceptance Criterion 5 – Drain inlet nozzle mass flux G should be limited to the following according to HEI [Ref. P6.2]:

$$G \leq 250 \text{ lb}_m/\text{sec}/\text{ft}^2 \quad (\text{Eq. P3-5})$$

$$\frac{G^2}{\rho} \leq 4000 \text{ lb}_m/\text{ft}/\text{sec}^2 \quad (\text{Eq. P3-6})$$

P3.2.6 Acceptance Criterion 6 – In order to be acceptable for tube vibration, the following criteria must be met:

- $f_n/f_e > 1$, in order to prevent resonant vortex shedding frequencies [Ref. P6.3]
- $V_{crit}/V > 1$, in order to prevent excessively large vibration amplitudes [Ref. P6.3]

As discussed in Section P3.1.7, the natural frequency and critical velocity can be considered constant relative to changes in operating conditions. Similarly, the vortex shedding frequency and cross flow velocity are directly proportional to drain cooler volumetric flow. Therefore, if drain cooler volumetric flow decreases, margins to the ratio criteria will increase.

P4.0 ASSUMPTIONS

None.

P5.0 DESIGN INPUTS

P5.1 Operating Conditions – Mass flow rates, pressures, temperatures, and enthalpies for various operating parameters are taken from the PEPSE results given in Attachment A.

P5.2 Feedwater Heater Tubes – The number of tubes, tube dimensions, total length of tube travel, design tube pressure drop, and percent tube plugging are given in Table P5-1 based on typical plant data.

Table P5-1: FWH Tube Side Dimensions

Heater Nos	# of Tubes	Tube Size	Thickness (in)	Tube I.D. (in)	Total Tube Length (ft)	Pressure Drop (psi)	Tube Plugging (-)
1 st EDC	396	1	0.035	0.930	15' 5"	6.6	15%
1 st Point	1201	5/8	0.035	0.555	33' 8"	15	5%
2 nd Point	797	3/4	0.035	0.680	46' 11"	15.7	5%
3 rd Point	767	3/4	0.035	0.680	42' 7"	15.1	5%
4 th Point	673	7/8	0.035	0.805	39' 7"	8.6	5%
5 th EDC	2798	5/8	0.035	0.555	13' 8"	3.1	15%
5 th Point	1842	3/4	0.035	0.680	29' 3"	10.5	5%
6 th Point	2037	3/4	0.035	0.680	33' 3"	9.4	5%
7 th Point	3583	5/8	0.058	0.509	24' 2"	10.9	5%

P5.3 Nozzle Sizes – The heater nozzle dimensions and the number of nozzles of each type are given in Table P5-2 based on typical plant data.

Table P5-2: FWH Nozzle Sizes

Heater Nos	Feedwater Inlet Nozzles		Feedwater Outlet Nozzles		Extraction Steam Nozzles			Inlet Drain Nozzles		Outlet Drain Nozzles	
	Dia (in)	I.D. (in)	Dia (in)	I.D. (in)	Qty.	Dia (in)	I.D. (in)	Dia (in)	I.D. (in)	Dia (in)	I.D. (in)
1 st EDC	18"	16.12	18"	16.12	-	-	-	18"	17.250	18"	17.25
1 st Point	18"	16.12	18"	16.12	4	30"	29.00	-	-	10"	10.02
2 nd Point	18"	16.12	18"	16.12	2	28"	27.00	12"	11.750	14"	13.25
3 rd Point	18"	16.12	18"	16.12	2	18"	17.00	8"	7.625	12"	12.00
4 th Point	18"	16.12	18"	16.12	1	20"	19.00	-	-	8"	7.98
5 th EDC	24"	21.56	24"	21.56	-	-	-	30"	29.250	30"	29.25
5 th Point	28"	26.13	28"	26.13	1	22"	20.25	See Note 1	See Note 1	26"	25.25
6 th Point	28"	26.13	28"	26.13	1	18"	16.88	18"	17.00	20"	19.25
7 th Point	28"	25.4	24"	20.4	1	14"	13.12	10" (x2)	9.562	18"	17.25

¹The fifth point FWHs have an 18-inch nozzle for cascading FWH drains (ID = 17.000") and two 8-inch nozzle for drains from each first stage reheater drain tank (ID = 7.625").

P6.0 REFERENCES

- P6.1 STMFUNC (Steam Table Function Dynamic Link Library) S&L Program Number 03.7.598 2.0, dated 06-11-2018.
- P6.2 Standards for Closed Feedwater Heaters. Heat Exchange Institute, Inc. Sixth Edition, 1998.
- P6.3 Standards of the Tubular Exchanger Manufacturers Association, Tubular Exchanger Manufacturers Association, Inc. Seventh Edition, 1988.

P7.0 EVALUATIONS**P7.1 Evaluation of Condensate/Feedwater Nozzle Velocities**

The following channel end nozzle velocities were computed for the feedwater heaters.

Table P7-1: Condensate/Feedwater Heater Nozzle Velocities (ft/s) for 70% Thermal Extraction

FW Heater	HEI Limit	Baseline (0% Extraction)	70% Extraction	Δ (70%)
1 st EDC	10	11.9	12.5	5.0%
1 st Point	10	11.9	12.5	5.0%
2 nd Point	10	11.9	12.5	5.0%
3 rd Point	10	11.9	12.5	5.0%
4 th Point	10	11.9	12.5	5.0%
5 th EDC	10	10.0	10.5	5.0%
5 th Point	10	9.6	8.6	-10.7%
6 th Point	10	9.6	8.6	-10.7%
7 th Point Inlet	10	10.2	9.1	-10.7%
7 th Point Outlet	10	15.8	14.1	-10.7%

Tube side nozzle velocities exceed the HEI guidelines for several of the FWHs, but changes from the baseline case are small or decrease. Therefore, it is not expected that feedwater nozzle wear will be an issue due to these changes.

P7.2 Evaluation of Tube Velocities

The following tube velocities were computed for the feedwater heaters. They are based on the density using the average tube temperature.

Table P7-2: Tube Velocity (ft/s) for 70% Thermal Extraction

FW Heater	HEI Limit	Baseline		Δ (70%)
		(0% Extraction)	70% Extraction	
1 st EDC	10	10.7	11.2	4.3%
1 st Point	10	8.9	9.3	3.8%
2 nd Point	10	9.1	9.4	2.9%
3 rd Point	10	9.6	9.8	2.0%
4 th Point	10	8.1	8.2	1.2%
5 th EDC	10	7.0	7.0	0.6%
5 th Point	10	9.1	7.8	-14.8%
6 th Point	10	8.5	7.2	-15.3%
7 th Point	10	8.8	7.4	-16.0%

Most tube velocities remain below the HEI guidelines for the 70% thermal extraction case. For the 1st EDC, the tube velocity is above the guideline, but the increase from the baseline scenario is minimal. Since changes are small, it is not expected that this will impact FWH tube degradation.

P7.3 Tube Side Pressure Drop

The following change in mass flow rates are used to evaluate the impact on PPP pressure loss based on the methodology outlined in Section P3.1.3. As the mass flow rate term is squared in the pressure loss equations, the ratio of flow rates is squared to determine the percent change in PPP pressure drop.

Table P7-3: Pass Partition Plate Pressure Loss for 70% Thermal Extraction

FW Heater	Baseline (0% Extraction) (lbm/hr)	70% Extraction (lbm/hr)	Ratio of Flow Rates (70%/Baseline)	Ratio of Flow Rates Squared (70%/Baseline) ²	PPP dP % Change
1 st EDC	3,778,163	3,966,967	105%	110%	10%
1 st Point	3,778,163	3,966,967	105%	110%	10%
2 nd Point	3,778,163	3,966,967	105%	110%	10%
3 rd Point	3,778,163	3,966,967	105%	110%	10%
4 th Point	3,778,163	3,966,967	105%	110%	10%
5 th EDC	5,667,245	5,950,450	105%	110%	10%
5 th Point	8,033,640	7,173,040	89%	80%	-20%
6 th Point	8,033,640	7,173,040	89%	80%	-20%
7 th Point	8,033,640	7,173,040	89%	80%	-20%

Attachment P
Feedwater Heater Evaluation – 70% Thermal Extraction

The pressure loss across the PP is expected to increase in FWHs 1 through 4 and both external drain coolers. However, the expected increase in tube side pressure drop for the 70% thermal extraction cases is not expected to appreciably impact reliable operation of the heaters.

P7.4 Steam Inlet and Drain Outlet Nozzle Velocity

The following steam inlet and drain outlet nozzle velocities were computed for the feedwater heaters.

Table P7-4: Steam Inlet Nozzle Velocity (ft/s) for 70% Thermal Extraction

FW Heater	HEI Limit	Baseline (0% Extraction)	70% Extraction	Δ (70%)
1 st Point	215	137	197	43.9%
2 nd Point	195	148	387	161.5%
3 rd Point	179	179	614	243.1%
4 th Point	167	156	466	199.4%
5 th Point	156	101	283	179.8%
6 th Point	150	103	210	103.8%
7 th Point	146	80	111	38.5%

Table P7-5: Drain Outlet Nozzle Velocity (ft/s) for 70% Thermal Extraction

FW Heater	HEI Limit	Baseline (0% Extraction)	70% Extraction	Δ (70%)
1 st EDC	4.0	2.3	1.5	-33.8%
1 st Point	4.0	1.8	0.5	-71.1%
2 nd Point	4.0	2.9	2.3	-21.1%
3 rd Point	4.0	2.4	2.1	-11.6%
4 th Point	4.0	2.8	2.4	-13.9%
5 th EDC	4.0	1.8	1.1	-37.6%
5 th Point	4.0	2.5	1.5	-38.0%
6 th Point	4.0	2.7	1.6	-39.5%
7 th Point	4.0	2.2	1.2	-44.9%

For the 70% thermal extraction scenario, steam inlet nozzle velocities increase for all FWHs and exceed the HEI guideline for the 2nd, 3rd, 4th, 5th, and 6th point heaters. This will increase stress on the impingement plates for these heaters, and the structural integrity of these plates will need to be evaluated to determine if they can withstand these conditions. Shell wear rates will also likely increase, and it should be noted that changes to steam inlet velocity can affect the wear pattern of the shell. Future inspections should be mindful of these changes. Flow accelerated

corrosion (FAC) evaluations should be performed to determine the operating impacts of these increased velocities.

Drain outlet velocities decrease, so HEI guidelines are not challenged, and wear rates may decrease.

P7.5 Drain Inlet Nozzle Mass Flux

The mass flux and mass flux parameter of flashing condensate flows entering the shell side of the feedwater heaters are shown in Table P7-6 for the 70% thermal extraction scenario.

Table P7-6: Heater Drain Inlet Nozzle Mass Flux and Mass Flux Parameter for 70% Thermal Extraction

FW Heater	Mass Flux (lbm/s/ft ²)				Mass Flux Parameter (lbm/ft/s ²)			
	HEI Limit	Baseline (0% Extraction)	70% Extraction	Δ (70%)	HEI Limit	Baseline (0% Extraction)	70% Extraction	Δ (70%)
1 st EDC	250	141	94	-33.5%	4,000	4,755	4947	4.0%
2 nd Point	250	148	135	-9.1%	4,000	6,491	6780	4.5%
3 rd Point	250	179	160	-10.8%	4,000	4,141	6333	52.9%
5 th EDC	250	102	66	-34.9%	4,000	190	77	-59.6%
5 th Point (cascading)	250	188	120	-36.3%	4,000	647	249	-61.5%
5 th Point (MSR)	250	119	34	-71.2%	4,000	4,409	828	-81.2%
6 th Point	250	118	69	-41.3%	4,000	515	149	-71.1%
7 th Point	250	112	74	-34.2%	4,000	2,177	4005	84.0%

For the 70% thermal extraction case, drain inlet mass fluxes remain below HEI guidelines, but the mass flux parameters for the 1st EDC and 2nd, 3rd, and 7th point heaters exceed the guidelines. This is an additional indicator that the impingement plates are at risk for structural damage under 70% thermal extraction conditions. These plates will need to be evaluated on plant-specific basis. If the subject station does not show sufficient margin to allow for these increases, the additional flashing steam could also increase wear rates at the drain inlet and future inspections should be mindful for changes.

P7.6 Operating Pressure and Temperature

Shell side operating pressure and tube side and shell side operating temperatures are compared for the baseline and 70% thermal extraction cases in Tables P7-7 through P7-9. The shell side operating temperature is the saturation temperature of steam at the operating shell side pressure.

Table P7-7: Shell Side Operating Pressures (psia) for 70% Thermal Extraction

FW Heater	Baseline (0% Extraction)	70% Extraction	Δ (70%)
1 st EDC	5.4	1.2	-77.0%
1 st Point	5.4	1.2	-77.0%
2 nd Point	15.9	3.7	-76.6%
3 rd Point	40.6	10.5	-74.0%
4 th Point	89.5	27.4	-69.4%
5 th EDC	186.1	64.0	-65.6%
5 th Point	186.1	64.0	-65.6%
6 th Point	287.1	105.3	-63.3%
7 th Point	408.7	148.7	-63.6%

Table P7-8: Shell Side Operating Temperatures (°F) for 70% Thermal Extraction

FW Heater	Baseline (0% Extraction)	70% Extraction	Δ (70%)
1 st EDC	165.6	109.2	-56.4°F
1 st Point	165.6	109.2	-56.4°F
2 nd Point	215.9	150.0	-65.9°F
3 rd Point	268.1	195.7	-72.4°F
4 th Point	319.9	245.2	-74.7°F
5 th EDC	375.8	297.0	-78.8°F
5 th Point	375.8	297.0	-78.8°F
6 th Point	413.3	331.6	-81.8°F
7 th Point	446.7	357.7	-89.0°F

Table P7-9: Tube Side Operating Temperatures (°F) for 70% Thermal Extraction

FW Heater	Baseline (0% Extraction)	70% Extraction	Δ (70%)
1 st EDC	126.6	94.5	-31.8°F
1 st Point	161.7	107.1	-54.0°F
2 nd Point	212.8	139.4	-70.7°F
3 rd Point	265.0	189.0	-74.1°F
4 th Point	316.4	237.1	-77.2°F
5 th EDC	332.2	248.4	-83.0°F
5 th Point	370.2	291.0	-78.9°F

FW Heater	Baseline (0% Extraction)	70% Extraction	Δ (70%)
6 th Point	409.7	328.2	-81.3°F
7 th Point	441.5	353.5	-86.7°F

Operating temperatures and pressures decrease for all FWHs, so margins to design values will improve for the thermal extraction cases.

P7.7 Drain Cooler Tube Vibration

Tube vibration in the 1st through 7th point heater drain coolers is evaluated by comparing the drain cooler volumetric flow rates.

Table P7-10: Drain Cooler Vibration for 70% Thermal Extraction

FW Heater No.	Drain Volumetric Flow (gpm)		
	Baseline (0% Extraction)	70% Extraction	Δ (70%)
1 st EDC	1,671	1,105	-33.8%
2 nd Point	1,240	978	-21.1%
3 rd Point	842	744	-11.6%
4 th Point	439	378	-13.9%
5 th EDC	3,767	2,349	-37.6%
6 th Point	2,434	1,472	-39.5%
7 th Point	1,578	870	-44.9%

As shown in Table P7-10, the volumetric flow through all drain coolers is expected to decrease during operation with 70% thermal extraction, resulting in increased margin for tube vibration parameters. Therefore, tube vibration is not expected to be caused by operating with 70% thermal extraction.

P8.0 RESULTS AND CONCLUSIONS

Tube and tube side nozzle velocities exceed the HEI guidelines for several of the FWHs, but changes from the baseline case are small or decrease, so it is not expected that FWH tube degradation or nozzle wear will be an issue due to 70% thermal extraction. Steam inlet nozzle velocities increase for all FWHs and exceed the HEI guidelines for the 2nd, 3rd, 4th, 5th, and 6th point heaters. This may cause over-stressing of the impingement plates, and shell wear rates will likely increase. It should also be noted that changes to steam inlet velocity can affect the wear pattern of the shell, and future inspections should be mindful for changes. Flow accelerated corrosion (FAC) evaluations should be performed to determine the operating impacts of these increased velocities. Drain outlet velocities decrease for the 70% thermal extraction case, so HEI guidelines are not challenged, and wear rates may decrease.

The pressure loss across the pass partition plate is expected to increase in FWHs 1 through 4 and both external drain coolers. However, the expected increase in tube side pressure drop for the 70% thermal extraction case is not expected to appreciably impact reliable operation of the heaters.

For the 70% thermal extraction case, drain inlet mass fluxes remain below HEI guidelines, but the mass flux parameters for the 1st EDC and 2nd, 3rd, and 7th point heaters exceed the guidelines. This is an additional indicator that the impingement plates are at risk for structural damage under 70% thermal extraction conditions. These plates will need to be evaluated on plant-specific basis. If the subject station does not show sufficient margin to allow for these increases, the additional flashing steam could also increase wear rates at the drain inlet and future inspections should be mindful for changes.

Operating temperatures and pressures decrease for all FWHs, so margins to design values will improve for the thermal extraction cases. Volumetric flow through all drain coolers is also expected to decrease during operation with 70% thermal extraction, resulting in increased margin for tube vibration parameters. Therefore, tube vibration is not expected to be caused by operating with 70% thermal extraction.

Attachment Q - Extraction Steam Evaluation with 70% Thermal Energy Extracted

Prepared: Gabriel Neimark

Reviewed: Nic Richards

Q1.0 PURPOSE

The purpose of this evaluation is to examine expected changes to operating conditions and performance parameters in relation to the design of the Extraction Steam (ES) System. This evaluation is performed for the scenario where 70% thermal energy is extracted from main steam.

Q2.0 SYSTEM & COMPONENT DESCRIPTION

To maximize steam cycle efficiency, the ES System diverts steam taken from the turbine to the feedwater heaters. There are three stages of extraction from the High Pressure (HP) turbine, and four stages of extraction from each Low Pressure (LP) turbine. The Extraction Steam is used to heat the feedwater in seven separate feedwater heater stages.

There are three trains for the 1st through 4th point LP feedwater heaters, two trains for the 5th and 6th point LP feedwater heaters, and two trains for the 7th point HP feedwater heater.

Q3.0 METHODOLOGY**Q3.1 Methodology****Q3.1.1 Extraction Steam Lines Pressure Drop**

Pressure drop in the ES lines will be evaluated using simplified incompressible flow methodology based on the Crane Technical Paper [pp. 3-4, Ref. Q6.3]. The following equation will be utilized to estimate the ES lines pressure drop:

$$\Delta P = 2.80 \times 10^{-7} \frac{KW^2 v}{d^5} \quad \text{Eq. Q3-1}$$

where:

ΔP = Pressure Drop [psi]
 K = Resistance Coefficient [ul]
 W = Mass Flow Rate [lbm/hr]
 v = Specific Volume [ft³/lbm]
 d = Piping Inside Diameter [in]

The K value for each segment of the ES piping, the saturation pressures of each feedwater heater shell, and the total mass flow rate of the ES from the PEPSE evaluation in Attachment A will be used to compute the pressure drop for each available line.

Q3.1.2 Operating Conditions

ES line pressures and temperatures from the PEPSE analysis in Attachment A are compared for the baseline and 70% thermal extraction scenarios. These comparisons are used to generalize the impacts on relevant valve and expansion joint service conditions.

Q3.1.3 Extraction Steam Expansion Joint Liner Thickness

The required expansion joint liner thicknesses for the baseline and 70% extraction cases are calculated using the following methodology and compared. Based on Section 4.10.2 of the EJMA standard [Ref. Q6.1], the minimum liner thickness for expansion joints between 12 to 24-inch diameters is 0.048-in and 0.060-in for diameters of 26 to 48-in. When the internal sleeve length exceeds 18-in, the standard liner thickness is to be multiplied by $(L/18)^{0.5}$ where L is the internal sleeve length in inches. When the flow velocity exceeds 100 ft/sec, the standard liner thickness is to be multiplied by $(V/100)^{0.5}$ where V is the liner velocity and is computed by (equation per page 3-2, [Ref. Q6.3]):

$$V = 0.0509 \frac{Wv}{d^2} \quad \text{Eq. Q3-2}$$

where:

V = Mean Velocity of Flow [ft/sec]

W = Mass Flow Rate [lb_m/hr]

v = Specific Volume [ft³/lb_m]

d = Piping Inside Diameter [in]

Where extremely turbulent flow is generated within 10 pipe diameters upstream of the expansion joint by valves, tees, and elbows, the flow velocity used in calculating the liner thickness shall be determined by multiplying the actual flow velocity by four [Ref. Q6.1]. Since the expansion joint assemblies have high Reynolds's numbers, the 'turbulent flow multiplier' is used.

When the fluid temperature exceeds 300°F, the thickness increase factor shall be equal to E_{sc}/E_{sh} where E_{sc} is the internal sleeve modulus of elasticity at 300°F and E_{sh} is the internal sleeve modulus of elasticity at the media temperature [Ref. Q6.1]. The only extraction line that experiences temperatures above 300°F is FWH 4 and the change in modulus of elasticity due to temperature change at baseline to 70% thermal power extraction conditions is expected to be negligible. Therefore, the temperature increase factor is ignored.

Q4.0 ASSUMPTIONS

Q4.1 Pressure Drop – Pressure loss is computed based on incompressible flow equations. Per Crane [Ref. Q6.3], if the calculated pressure drop is less than about 10% of the inlet pressure, reasonable accuracy will be obtained if specific volume is based on either upstream or downstream conditions. Similarly, for pressure drop between 10% and 40% of inlet pressure, specific volume based on the average upstream and downstream conditions can be used. For conservatism, the specific volume of steam/steam water mixture is based on the feedwater heater shell pressure and the turbine extraction point enthalpy. Using the end-point pressure to determine specific volume is conservative with respect to pressure drop and line velocity.

Q4.2 Flow Rate – It is assumed that the flow rate is equal in all heater trains from the HP Turbine. The flow rate is used as input for the calculation of ES line pressure drop. While some flow variation between trains may exist, it will affect the losses associated with piping to only a small degree. The piping loss is a very small part of the total line loss, which accounts for losses due to various components such as elbows and valves. Loss factors for these components are typically conservative in nature. Also note that the higher flow from either string from the PEPSE analysis (see Attachment A) is used. This should provide adequate allowance and margin for differences between heater strings.

Q5.0 DESIGN INPUTS

Q5.1 Operating Parameters

ES flows, temperatures, pressures, and enthalpies are taken from the PEPSE results given in Attachment A. For this analysis, the maximum values for mass flow, pressure, and enthalpy from the three strings for FWHs 1-4 are used. The pressure subscripts 'US' and 'DS' indicate upstream and downstream, respectively. Specific volume is based on downstream pressure, yielding a higher result which is conservative with respect to flow velocity. This is consistent with Assumption Q4.1. Temperature is based on upstream pressure, yielding a higher temperature which is conservative with respect to maximum rated temperature for equipment. Both specific volume and temperature are calculated with the Excel STMFUNC add-in [Ref. Q6.2].

Table Q5-1: Heat Balance Data – 0% Extraction

Parameter	Mass Flow W (lb _m /hr)	Pressure P _{DS} (psia)	Pressure P _{US} (psia)	Enthalpy h (Btu/lb _m)	Spec. Vol v _{DS} (ft ³ /lb _m)	Temp. T _{US} (°F)
HP Turbine to 1 st Stg. Rhtr	1.36E+05	448.7	451.0	1159.0	0.97	456.5
HP Turbine to 7th Stg. FWH	5.16E+05	408.7	451.0	1144.6	1.05	456.5
HP Turbine to 6th Stg. FWH	8.01E+05	287.1	296.5	1114.2	1.44	416.3
HP Turbine to 5th Stg. FWH	7.47E+05	186.1	190.3	1104.0	2.18	377.6
LP Turbine to 4th Stg. FWH	6.13E+05	89.6	92.4	1219.2	5.39	382.5
LP Turbine to 3rd Stg. FWH	5.96E+05	40.6	41.9	1158.8	10.2	270.1
LP Turbine to 2nd Stg. FWH	6.23E+05	15.9	16.4	976.3	20.4	217.7
LP Turbine to 1st Stg. FWH	6.63E+05	5.4	5.4	730.6	40.7	165.7

Table Q5-2: Heat Balance Data – 70% Extraction

Parameter	Mass Flow W (lb _m /hr)	Pressure P _{DS} (psig)	Pressure P _{US} (psig)	Enthalpy h (Btu/lb _m)	Spec. Vol v _{DS} (ft ³ /lb _m)	Temp. T _{US} (°F)
HP Turbine to 1 st Stg. Rhtr	3.91E+04	175.1	176.0	1192.1	2.6	371.2
HP Turbine to 7th Stg. FWH	2.48E+05	148.7	176.0	1190.0	3.0	371.2
HP Turbine to 6th Stg. FWH	5.76E+05	105.3	108.8	1156.7	4.1	334.0
HP Turbine to 5th Stg. FWH	7.15E+05	64.0	65.5	1128.6	6.4	298.5
LP Turbine to 4th Stg. FWH	5.47E+05	27.5	28.4	1229.9	18.0	383.2
LP Turbine to 3rd Stg. FWH	5.48E+05	10.6	10.9	1157.3	38.0	223.4
LP Turbine to 2nd Stg. FWH	3.66E+05	3.8	3.9	1061.1	90.0	151.7
LP Turbine to 1st Stg. FWH	1.95E+05	1.3	1.3	838.8	198.2	109.6

Q5.2 Expansion Joint Design Data

The input used to calculate the expansion joint required liner thickness is given below based on a typical plant configuration.

Table Q5-3: Expansion Joint Design Data

Expansion Joint Location	Nom. Dia.	Liner ID	Liner Length
	[in.]	[in.]	[in.]
4 th Point Heater	14	11.75	9.63
3 rd Point Heater	18	15.75	9.75
2 nd Point Heater	28	25.25	9.75
1 st Point Heater	30	27.25	15.25

Q5.3 Line Information

The extraction steam piping information used to calculate pressure drop for each line is given below based on a typical plant configuration.

Table Q5-4: ES Line Information

	Piping Segment	Pipe ID (in)	Total K
HPT to 7th Stg FWH	Turb Extraction A	13.12	2.491
	Turb Extraction B	13.12	2.772
	Turb Extraction	18.81	3.945
	To Heater 7A	13.12	3.09
	To Heater 7B	13.12	3.342
HPT to 6th Stg FWH	Turb Extraction A	16.88	1.738

Attachment Q
Extraction Steam Evaluation – 70% Thermal Extraction

	Piping Segment	Pipe ID (in)	Total K
	Turb Extraction B	16.88	1.623
	Turb Extraction	22.62	4.204
	To Heater 6A	16.88	3.59
	To Heater 6B	16.88	3.814
HPT to 5th Stg FWH	Turb Extraction A	18.81	2.917
	Turb Extraction B	18.81	2.368
	Turb Extraction	29.00	4.043
	To Heater 5A	22.62	3.179
	To Heater 5B	22.62	3.63
LPT to 4th Stg FWH	Turb Extraction	13.00	2.467
	To Heater 4A	19.00	6.113
	Turb Extraction	13.00	2.467
	To Heater 4B	19.00	5.683
	Turb Extraction	13.00	2.467
	To Heater 4C	19.00	6.141
LPT to 3rd Stg FWH	Turb Extraction	17.00	3.047
	Turb Extraction	23.00	3.518
	To Heater 3A	17.00	2.317
	Turb Extraction	17.00	3.098
	Turb Extraction	23.00	3.45
	To Heater 3B	17.00	2.339
	Turb Extraction	17.00	3.098
	Turb Extraction	23.00	3.5
	To Heater 3C	17.00	2.339
LPT to 2nd Stg FWH	Turb Extraction	27.00	1.872
	Turb Extraction	39.00	3.001
	To Heater 2A	27.00	2.038
	Turb Extraction	27.00	1.872
	Turb Extraction	39.00	3.076
	To Heater 2B	27.00	2.038
	Turb Extraction	27.00	1.872
	Turb Extraction	39.00	3.072
	To Heater 2C	27.00	2.056
LPT to 1st Stg FWH	To Heater 1A	29.00	2.439
	To Heater 1A	29.00	2.116
	To Heater 1A	29.00	2.705
	To Heater 1A	29.00	2.345

Q6.0 REFERENCES

- Q6.1 Standards of the Expansion Joint Manufacturers Association (EJMA), Inc., Ninth Edition, 2008.
- Q6.2 STMFUNC (Steam Table Function Dynamic Link Library) S&L Program Number 03.7.598 2.0, dated 06-11-2018.
- Q6.3 Crane Technical Paper No. 410, *Flow of Fluids Through Valves, Fittings, and Pipe*, Twenty Fifth Printing, 1991.
- Q6.4 Standards of the Expansion Joint Manufacturers Association (EJMA), Inc., Ninth Edition, 2008.

Q7.0 EVALUATIONSQ7.1 Pressure Drop

ES line pressure drops are compared for the baseline and 70% thermal extraction scenarios in Tables Q7-1.

Table Q7-1: ES Line Pressure Drop for 70% Thermal Extraction

	Upstream Pressure [psia]			Pressure Drop [psid]		
	0%	70%	Delta	0%	70%	Delta
HPT to 7th Stg FWH	451.0	176.0	-61.0%	6.50	4.33	-33.4%
HPT to 6th Stg FWH	296.5	108.8	-63.3%	8.46	12.42	46.8%
HPT to 5th Stg FWH	190.3	65.5	-65.6%	4.97	13.32	168.1%
LPT to 4th Stg FWH	92.39	28.39	-69.3%	4.33	11.53	166.3%
LPT to 3rd Stg FWH	41.9	10.93	-73.9%	3.24	10.21	214.6%
LPT to 2nd Stg FWH	16.43	3.88	-76.4%	0.78	1.19	52.5%
LPT to 1st Stg FWH	5.428	1.259	-76.8%	0.13	0.06	-58.0%

The pressure drop in the lines from the HPT to 7th stage FWHs and LPTs to 1st stage FWHs decreases, but all other extraction steam lines see an increase in pressure drop for the 70% thermal extraction case due to higher flow velocities. The most significant changes are in lines to the 3rd, 4th, and 5th stage FWHs which have an increase in pressure drop of greater than 150%.

Q7.2 Operating Conditions

ES line pressures and temperatures for the baseline and 70% thermal extraction scenarios are compared in Tables Q7-2.

Table Q7-2: ES Line Operating Conditions for 70% Thermal Extraction

	Line Pressure [psia]			Line Temperature [°F]		
	0%	70%	Delta	0%	70%	Delta
HPT to 1st Stg Rhtr	448.7	256.2	-42.9%	456.5	371.2	-85.3°F
HPT to 7th Stg FWH	408.7	224.5	-45.1%	456.5	371.2	-85.3°F
HPT to 6th Stg FWH	287.1	157.5	-45.1%	416.3	334.0	-82.3°F
HPT to 5th Stg FWH	186.1	95.5	-48.7%	377.6	298.5	-79.2°F
LPT to 4th Stg FWH	89.6	44.8	-50.0%	382.5	383.2	0.6°F
LPT to 3rd Stg FWH	40.6	19.4	-52.3%	270.1	223.4	-46.7°F
LPT to 2nd Stg FWH	15.9	7.3	-54.0%	217.7	151.7	-66.0°F
LPT to 1st Stg FWH	5.4	2.5	-54.5%	165.7	109.6	-56.2°F

Pressures and temperatures decrease for the thermal extraction cases in all lines other than a small temperature increase (< 1°F) in the 4th Stg FWH line. Based on these results, margins for design pressures and temperatures will largely improve for relevant valves and expansion joints.

Q7.3 Expansion Joint Required Liner Thickness

Required liner thicknesses for the baseline and 70% thermal extraction scenarios are compared in Tables Q7-3.

Table Q7-3: Expansion Joint Required Liner Thickness for 70% Thermal Extraction

	Required Liner Thickness [in]		
	0%	70%	Delta
LPT to 4th Stg FWH	0.137	0.236	72.8%
LPT to 3rd Stg FWH	0.138	0.256	84.9%
LPT to 2nd Stg FWH	0.156	0.251	61.1%
LPT to 1st Stg FWH	0.149	0.178	19.6%

Liner thickness requirements increase for the thermal extraction case. Existing expansion joints will need to be evaluated on a plant-specific basis and may need to be replaced to ensure they meet these new requirements.

Q8.0 RESULTS AND CONCLUSIONS

Analysis of the extraction steam system for the 70% thermal extraction scenario shows that overall, extraction steam line pressure drops increase due to higher flow velocities, with lines to the 3rd, 4th, and 5th stage feedwater heaters seeing an increase of over 150%. Expansion joint liner thickness requirements also increase by up to 85%. Existing expansion joints will need to be evaluated on a plant-specific basis and may need to be replaced to ensure they meet these new requirements.

Attachment Q
Extraction Steam Evaluation – 70% Thermal Extraction

Pressures and temperatures mostly decrease during operation with thermal extraction, so margins for design pressures and temperatures will largely improve for valves and expansion joints in the extraction steam system. The only exception is a slight temperature increase ($< 1^{\circ}\text{F}$) in the 4th Stage FWH extraction line. This slight increase is expected to be within the design margin of a typical plant.

Attachment R – Heater Drain System Assessment with 70% Thermal Energy Extracted

Prepared: Gabriel Neimark

Reviewed: Nic Richards

Attachment R
Heater Drain System Assessment – 70% Thermal Extraction

R1.0 PURPOSE

The purpose of this appendix is to assess the heater drain system performance and expected changes to operating conditions due to operation with 70% turbine cycle thermal energy extracted from the main steam.

R2.0 SYSTEM & COMPONENT DESCRIPTION**R2.1 System Description**

There are seven stages of feedwater heating for normal operations. Two parallel trains ('A' and 'B' trains), each consisting of a feedwater heater (FWH) 5, 6 and 7, are available for normal operation. Drains cascade back to the heater drain tank (HDT) starting at FWH 7. Flow for each train passes through the FWH 5 external drain coolers before entering the HDT. Emergency drains to the condenser are available for FWHs 5, 6, and 7.

Three parallel FWH drain trains ('A' train, 'B' train, and 'C' train), each consisting of a FWH 1, 2, 3, and 4, are available for normal operation. Drains cascade from FWH 4 to the flash tanks through FWHs 3 and 2. FWHs 1 drain to the flash tanks as well. Each flash tank drains to the condenser via the FWH 1 external drain coolers. Emergency drains to the condenser are available for FWHs 4, 3, and 2, as well as the flash tanks.

Four MSR drain trains ('A' train, 'B' train, 'C' train, and 'D' train), each consisting of a moisture separator drain tank (MSDT), 1st stage reheater drain tank (RH1DT), and a 2nd stage reheater drain tank (RH2DT), are available for normal operation as well. The MSDT drains are directed to the HDT. The 1st and 2nd stage reheater drains are directed to FWHs 5 and 7, respectively. Emergency drain lines to the condenser are available for each of the drain lines.

R2.2 Component Description*a) Normal and Emergency Drain Control Valves*

The normal and emergency drain flow paths for each component are described below:

Table R2-1 – Component Flow Path Descriptions

Service	Source	Destination
7 th Point Normal	FWH 7	FWH 6
7 th Point Emergency	FWH 7	Condenser
6 th Point Normal	FWH 6	FWH 5
6 th Point Emergency	FWH 6	Condenser
5 th Point Normal	FWH 5	DC 5
5 th Point Emergency	FWH 5	Condenser
Drain Cooler 5 Normal	DC 5	HDT
Drain Cooler 5 Emergency	N/A	N/A
4 th Point Normal	FWH 4	FWH 3
4 th Point Emergency	FWH 4	Condenser

Attachment R
Heater Drain System Assessment – 70% Thermal Extraction

Service	Source	Destination
3rd Point Normal	FWH 3	FWH 2
3rd Point Emergency	FWH 3	Condenser
2nd Point Normal	FWH 2	Flash Tanks
2nd Point Emergency	FWH 2	Condenser
1st Point Normal	FWH 1	Flash Tanks
1st Point Emergency	N/A	N/A
Flash Tank Normal	Flash Tanks	DC 1
Flash Tank Emergency	Flash Tanks	Condenser
Drain Coolers 1 Normal	DC 1	Condenser
Drain Coolers 1 Emergency	N/A	N/A
HDT Normal	FWH Drain Tank	Condensate Booster System
HDT Emergency	FWH Drain Tank	Condenser
RH2DT Normal	2 nd Stage Drain Tanks	FWH 7
RH2DT Emergency	2 nd Stage Drain Tanks	Condenser
RH1DT Normal	1 st Stage Drain Tanks	FWH 5
RH1DT Emergency	1 st Stage Drain Tanks	Condenser
MSDT Normal	MSR Shell Drain Tanks	HDT
MSDT Emergency	MSR Shell Drain Tanks	Condenser

b) Drain Tanks

Drain tanks are provided to collect condensed steam from the moisture separators, 1st and 2nd stage reheaters, and feedwater heaters. The drain tanks in the HD system include:

- i) Heater Drain Tank
- ii) Moisture Separator Drain Tanks
- iii) 1st Stage Reheater Drain Tanks
- iv) 2nd Stage Reheater Drain Tanks
- v) Flash Tanks

c) Heater Drain Pumps

The HDPs function to pump drains collected in the HDT forward to the condensate system through control valves. There are three 50% capacity HDPs. Normally two pumps operate with a third in standby. These pumps and control valves are evaluated in the Power Train Pumps Assessment (see Attachment K)

Attachment R
Heater Drain System Assessment – 70% Thermal Extraction

R3.0 METHODOLOGY**R3.1 Required Drain Control Valve (DCV) Capacity**

The flow capacity (C_v) of a control valve is a function of the valve body, valve trim, valve stem position, fluid properties of inlet liquid, and downstream backpressure. The methodology for evaluating the capacity is the standard industry method as outlined in the Masoneilan Control Valve Sizing Handbook [Ref. R6.1]. For the evaluations here, the required duty (in lb_m/hr) is taken from the heat balances (see Design Input R5.1). The C_v required of the valve is then determined and the required valve flow coefficient during 70% thermal power extraction operating conditions is compared against the baseline valve C_v to determine the impact operating with thermal power extraction has on the level control valves.

The steps in the determination are as follows:

- Determine the required mass flow rate (see Design Input R5.1 for inputs used).
- Determine the valve inlet water temperature and pressure (see Design Input R5.1 for inputs used).
- Determine valve inlet pressure (see Section R3.1.1).
- Determine the pressure differential at which the valve chokes. This is termed the ‘allowable pressure differential’ as any further decrease in downstream pressure (increase in valve pressure differential) will not increase the mass flow rate through the valve. Required input for this includes the pressure recovery factor (F_L), the inlet pressure (P_1), the critical pressure ratio factor (F_F), and the saturation vapor pressure at the valve inlet (P_v).
- Determine the valve outlet pressure if no choking occurs (see Section R3.1.3) to determine valve pressure drop without choking (valve inlet pressure minus valve outlet pressure).
- Set the ‘available pressure drop’ across the valve equal to the smaller of the two pressure drops from above.
- Determine the required C_v based on the volumetric flow rate, the entering fluid specific gravity, and the available pressure drop.
- Compare the required C_v to the VWO C_v .

R3.1.1 *Valve Inlet Pressure*

The inlet pressure to the control valve is calculated based on the upstream heater shell side pressure. Elevation head between the operating level in the heater and the centerline elevation of the valve is then added/subtracted from this pressure. Next, the pressure drop through the drain cooler or upstream FWH is subtracted, if applicable. Pressure loss in the piping between the upstream heater and the valve is computed using Crane [Ref. R6.2]. These pressure differentials are based on generic plant input.

Attachment R
Heater Drain System Assessment – 70% Thermal Extraction

R3.1.2 Allowable Pressure Drop

The allowable pressure drop is based on the choked pressure drop of the valve and is defined as follows [Ref. R6.1]:

$$\Delta P_{ch} = F_L^2 (P_1 - F_F P_V) \quad \text{Eq. R3-1}$$

where:

ΔP_{ch}	Pressure differential at which the flow chokes [psid]
F_L	Pressure recovery factor (see Assumption R4.1)
P_1	Valve inlet pressure [psia]
F_F	Critical pressure ratio factor (see Equation R3-3)
P_V	Vapor pressure of water at inlet temperature [psia]

and

$$F_F = 0.96 - 0.28 \sqrt{P_V / P_C} \quad \text{Eq. R3-2}$$

where:

F_F	Critical pressure ratio
P_V	Valve inlet vapor pressure [psia]
P_C	Critical pressure of water, 3206 psia [Ref. R6.1]

R3.1.3 Pressure Drop Based on Friction Flow in the Downstream Piping

In addition to the allowable pressure drop based on the valve characteristics, there is also an available pressure drop across the valve based on frictional pressure drop and elevation changes in the downstream piping. These pressure differentials are based on generic plant input. The resulting outlet pressure is then subtracted from the inlet pressure (see Section R3.1.1), giving an available pressure drop across the valve.

R3.1.4 Control Valve Liquid Flow Coefficient C_V

Control valve C_V is defined as [Ref. R6.1]:

$$C_V = \frac{q}{F_P \sqrt{\Delta P_a}} \sqrt{\frac{G_F}{\Delta P_a}} \quad \text{Eq. R3-3}$$

where:

C_V	Valve flow sizing coefficient
q	Flow rate [gpm]
F_P	Piping geometry factor
ΔP_a	Allowable pressure drop across the valve [psid]
G_f	Specific gravity of fluid

Attachment R
Heater Drain System Assessment – 70% Thermal Extraction

In the expression above, q and G_f are based on the entering fluid volumetric flow rate, pressure and temperature. The pressure drop is taken as the minimum of (i) the allowable pressure drop based on choked flow considerations and of (ii) the available pressure drop from frictional and elevation head pressure drop evaluations. Pipe fittings are accounted for in the generic pipe plant losses so the piping geometry factor is not used.

R3.2 Tank Parameters

Operating parameters of the system tanks are reviewed to evaluate the impact of operating with thermal power extraction.

R4.0 ASSUMPTIONS

R4.1 Valve Pressure Recovery Factor (F_L)

A generic pressure recovery factor of $F_L = 0.85$ is used based on typical industry values.

R5.0 DESIGN INPUTS

R5.1 FWH Drain Baseline and 70% Thermal Extraction Conditions

Drain flows, pressures, and temperatures are taken from Attachment A and averaged across the available strings. The average values for the baseline and 70% Thermal Extraction cases are presented in Table R5-1 below.

Table R5-1 – Average FWH Drain Conditions

Parameter	Units	Baseline (0% Extraction)	70% Extraction
MSDT Drain Flow	lbm/hr	331,167	55,451
MSDT Drain Pressure	psia	184.6	63.5
MSDT Drain Temperature	°F	375.1	296.4
RH1DT Drain Flow	lbm/hr	135,811	39,071
RH1DT Drain Pressure	psia	444.2	173.4
RH1DT Drain Temperature	°F	455.0	370.0
RH2DT Drain Flow	lbm/hr	200,488	131,857
RH2DT Drain Pressure	psia	864.2	877.9
RH2DT Drain Temperature	°F	527.2	529.0
FWH 3 LPT to Pressure	psia	40.6	10.6
FWH 4 LPT to Flow	lbm/hr	202,252	180,267
FWH 4 LPT to Pressure	psia	89.5	27.5
FWH 1 Extraction Pressure	psia	5.42	1.25
FWH 1 Drain Temp	°F	165.2	108.8
FWH 2 Extraction Pressure	psia	15.9	3.7
FWH 2 Drain Temp	°F	169.9	111.5
FWH 3 Extraction Pressure	psia	40.6	10.6

Attachment R
Heater Drain System Assessment – 70% Thermal Extraction

Parameter	Units	Baseline (0% Extraction)	70% Extraction
FWH 3 Drain Temp	°F	225.4	152.8
FWH 4 Extraction Pressure	psia	89.5	27.5
FWH 4 Drain Temp	°F	275.5	199.7
FWH 5 Extraction Pressure	psia	186.1	64.0
FWH 5 Drain Temp	°F	375.8	296.8
FWH 6 Extraction Pressure	psia	287.1	105.3
FWH 6 Drain Temp	°F	374.9	292.7
FWH 7 Extraction Pressure	psia	408.7	148.7
FWH 7 Drain Temp	°F	421.0	333.8
FWH 7 Drain Flow	lbm/hr	658,822	387,657
FWH 6 Drain Flow	lbm/hr	1,059,170	675,899
DC 5 Drain Flow	lbm/hr	1,704,062	1,111,688
FWH 4 Drain Flow	lbm/hr	202,252	180,267
FWH 3 Drain Flow	lbm/hr	398,540	362,420
FWH 2 Drain Flow	lbm/hr	601,704	481,927
DC 1 Drain Flow	lbm/hr	821,877	546,517
Condenser Shell Pressure	psia	1.42	0.79

R6.0 REFERENCES

- R6.1 BHMN-Valve-Sizing-Handbook-TS-19540C-0222, "Masoneilan Control Valve Sizing Handbook," Baker Hughes, 02/2022
- R6.2 Flow of Fluids Through Valve, Fittings, and Pipe, Crane Technical Paper No. 410, 1991
- R6.3 STMFUNC, "Steam Table Function Dynamic Link Library," S&L Program Number 03.7.598-2.0

Attachment R
Heater Drain System Assessment – 70% Thermal Extraction

R7.0 EVALUATIONS**R7.1 Valve Flow Capacity****R7.1.1 *Valve Flow***

Valve volumetric flow is computed based on the mass flow rate and fluid temperature. The liquid density is computed using Excel add-on STMFUNC [Ref. R6.3]. Table R7-1 provides a comparison of the volumetric mass flow rates.

Table R7-1 – Drain Volumetric Flow Comparison

Description	Baseline [gpm]	70% Extraction	
		Flow Rate [gpm]	Percent Change [-]
Flash Tank Normal	1,683	1,101	-34.6%
FWH 2 Normal	1,234	972	-21.3%
FWH 3 Normal	836	739	-11.5%
FWH 4 Normal	434	374	-13.9%
FWH 6 Normal	2,416	1,465	-39.4%
FWH 7 Normal	1,557	861	-44.7%
MSDT Normal	756	120	-84.1%
RHDT1 Normal	331	89	-73.1%
RHDT2 Normal	527	348	-34.1%
Flash Tank Emergency	1,683	1,101	-34.6%
FWH 2 Emergency	1,234	972	-21.3%
FWH 3 Emergency	836	739	-11.5%
FWH 4 Emergency	434	374	-13.9%
FWH 5 Emergency	3,890	2,415	-37.9%
FWH 6 Emergency	2,416	1,465	-39.4%
FWH 7 Emergency	1,557	861	-44.7%
MSDT Emergency	756	120	-84.1%
RHDT1 Emergency	331	89	-73.1%
RHDT2 Emergency	527	348	-34.1%

As shown in Table R7-1, drain flows decrease between 11% and 85% when 70% thermal power is extracted.

Attachment R
Heater Drain System Assessment – 70% Thermal Extraction

R7.1.2 Valve Pressure Drop

The pressure drop across the valve is the minimum of the allowable pressure drop due to choked flow (see Section R3.1.2) and the available pressure drop from valve inlet to outlet based on flow conditions and frictional losses (see Section R3.1.3). Table R7-2 provides the computed pressure losses for each thermal extraction scenario. The minimum pressure loss for each valve is shown in **bold** text.

Table R7-2 – Drain Valve Pressure Loss for 70% Thermal Extraction

Description	Baseline (0% Extraction)		70% Extraction		Percent Change	
	Choked dP [psid]	Available dP [psid]	Choked dP [psid]	Available dP [psid]	Choked dP [-]	Available dP [-]
Flash Tank Normal	2.7	7.3	3.4	5.1	28.1%	-30.3%
FWH 2 Normal	2.3	3.2	-1.6	-2.4	-167.2%	-174.2%
FWH 3 Normal	9.1	14.6	-1.5	-2.1	-116.9%	-114.3%
FWH 4 Normal	32.1	44.5	10.7	13.7	-66.8%	-69.1%
FWH 6 Normal	85.0	95.9	33.1	37.0	-61.1%	-61.4%
FWH 7 Normal	90.9	108.1	28.8	30.4	-68.3%	-71.9%
MSDT Normal	19.6	5.9	9.4	7.4	-52.2%	26.7%
RHDT1 Normal	42.7	249.3	10.4	102.5	-75.7%	-58.9%
RHDT2 Normal	115.6	454.6	118.8	729.7	2.8%	60.5%
Flash Tank Emergency	4.1	9.2	4.0	5.9	-1.2%	-35.7%
FWH 2 Emergency	5.5	11.7	1.7	2.7	-69.3%	-76.8%
FWH 3 Emergency	15.0	37.1	4.6	9.2	-69.4%	-75.1%
FWH 4 Emergency	38.4	92.0	17.3	32.3	-54.9%	-64.9%
FWH 5 Emergency	23.0	196.4	13.0	76.0	-43.4%	-61.3%
FWH 6 Emergency	86.9	283.3	35.1	103.1	-59.6%	-63.6%
FWH 7 Emergency	97.5	405.9	35.8	147.4	-63.3%	-63.7%
MSDT Emergency	16.4	186.0	5.9	65.8	-64.0%	-64.6%
RHDT1 Emergency	47.6	444.7	15.2	175.3	-68.2%	-60.6%
RHDT2 Emergency	116.8	862.6	120.6	880.1	3.3%	2.0%

As shown in Table R7-2, all drain control valves experience choked flow conditions except for the moisture separator drain tank under normal operating conditions. The FWH 2 and 3 normal drain control valves exhibits excessive inlet and outlet pressure drop resulting in a negative pressure loss, which is not possible. Adjustments to the plant operation would be required in order to maintain normal operation. This could include opening of the emergency dump valves or opening of the LP FWH bypass as is shown in Attachment O for the 50% thermal extraction case. With respect to valve capacity, a decrease in valve pressure loss is non-conservative, as the pressure loss is in the denominator (see Equation R3-3). Therefore, nearly all valves see a non-conservative reduction in allowable pressure loss, with the exception of the flash tank normal

Attachment R
Heater Drain System Assessment – 70% Thermal Extraction

drain valves, moisture separator drain tank normal drain valves, and 2nd stage reheater drain tank emergency and normal drain valves. In most cases, the reduction in allowable pressure drop is significant. The resulting impact on required C_v is discussed in Section R7.1.3.

R7.1.3 Required Valve C_v

The resulting required valve C_v values are presented in Table R7-3. Increases in C_v are shown in **bold text**.

Table R7-3 – Drain Valve Required C_v Capacity

Description	Baseline (0% Extraction) [-]	70% Extraction	
		C_v [-]	Percent Change [-]
Flash Tank Normal	1019	594	-41.7%
FWH 2 Normal	796	N/A	N/A
FWH 3 Normal	271	N/A	N/A
FWH 4 Normal	74	112	51.9%
FWH 6 Normal	245	245	-0.3%
FWH 7 Normal	150	152	1.3%
MSDT Normal	292	42	-85.5%
RHDT1 Normal	46	26	-43.6%
RHDT2 Normal	43	28	-35.0%
Flash Tank Emergency	823	546	-33.6%
FWH 2 Emergency	520	744	43.3%
FWH 3 Emergency	211	341	62.0%
FWH 4 Emergency	68	88	30.5%
FWH 5 Emergency	759	642	-15.4%
FWH 6 Emergency	243	237	-2.1%
FWH 7 Emergency	145	136	-5.9%
MSDT Emergency	175	48	-72.8%
RHDT1 Emergency	43	21	-50.7%
RHDT2 Emergency	43	28	-35.2%

As shown in Table R7-3, the required C_v capacity for FWH 2, 3, and 4 emergency DCVs and the FWH 4 normal DCV increases significantly and would require station specific review for valve acceptability. FWH 7 exhibits a required increase of less than 5%, which is typically within the operating margin of a well sized drain control valve. Therefore, no equipment changes would be expected for this FWH DCV, but a station specific review is required. For the reference plant, the normal DCVs for FWHs 2 and 3 cannot meet the flow capacity requirements of 70% thermal extraction and would require operational and/or design changes in order to satisfy system requirements. This would need to be determined based on the plant specific evaluation. Flash tank and the various MSR drain tanks all see reduced capacity requirements.

Attachment R
Heater Drain System Assessment – 70% Thermal Extraction

R7.2 Drain Tank Parameters

The operating parameters for the drain tanks (MSDT, RH1DT, RH2DT, & Flash Tank) are reviewed for the 70% thermal extraction scenarios in Table R7-4.

Table R7-4 – Drain Tank Conditions for 70% Thermal Extraction

Parameter	Units	Baseline (0% Extraction)	70% Thermal Extraction	Percent Change [-]
MSDT Drain Flow	<i>lbm/hr</i>	331,167	55,451	-83.3%
RH1DT Drain Flow	<i>lbm/hr</i>	135,811	39,071	-71.2%
RH2DT Drain Flow	<i>lbm/hr</i>	200,488	131,857	-34.2%
Flash Tank Drain Flow	<i>lbm/hr</i>	821,877	546,517	-33.5%
MSDT Drain Pressure	<i>psia</i>	184.6	63.5	-65.6%
RH1DT Drain Pressure	<i>psia</i>	444.2	173.4	-61.0%
RH2DT Drain Pressure	<i>psia</i>	864.2	877.9	1.6%
Flash Tank Drain Pressure	<i>psia</i>	5.42	1.25	-76.9%
MSDT Drain Temperature	<i>°F</i>	375.1	296.4	-78.7°F
RH1DT Drain Temperature	<i>°F</i>	455.0	370.0	-85.0°F
RH2DT Drain Temperature	<i>°F</i>	527.2	529.0	1.9°F
Flash Tank Drain Temperature	<i>°F</i>	165.2	108.8	-56.4°F

As shown in Table R7-4, mass flow rates decrease for all drain tanks. Pressure and temperatures also decrease for all tanks except the 2nd stage reheater drain tank. Conditions for RH2DT show minimal change. As all parameters either decrease or show minimal change, the heater drain system drain tanks are expected to operate normally during thermal power extraction operation.

R8.0 RESULTS AND CONCLUSIONS

The required C_v capacity for all the flash tank and the various MSR drain tanks DCVs show reduced capacity requirements when operating with 70% thermal power extraction. FWHs 6 and 7 exhibit required increases of less than 5%, so no equipment changes are expected. FWH 2, 3, and 4 emergency DCVs and the FWH 4 normal DCV requirements increase significantly (> 30%), and it is expected that a station specific review of these FWHs would require valve/trim replacement prior to operation with thermal power extracted. The normal DCVs for FWHs 2 and 3 cannot meet the flow capacity requirements of 70% thermal extraction and would require operational and/or design changes in order to satisfy system requirements. This would need to be determined based on the plant specific evaluation.

Operating parameters for all heater drain system drain tanks either decrease or show minimal change and are expected to operate normally during 70% thermal power extraction.