

# Installation of Halden Reactor Project Digital Interface Prototypes in the Human Systems Simulation Laboratory

OECD Halden Reactor Project

May 2013



The INL is a U.S. Department of Energy National Laboratory  
operated by Battelle Energy Alliance



**DISCLAIMER**

This information was prepared as an account of work sponsored by an agency of the U.S. Government. Neither the U.S. Government nor any agency thereof, nor any of their employees, makes any warranty, expressed or implied, or assumes any legal liability or responsibility for the accuracy, completeness, or usefulness, of any information, apparatus, product, or process disclosed, or represents that its use would not infringe privately owned rights. References herein to any specific commercial product, process, or service by trade name, trade mark, manufacturer, or otherwise, does not necessarily constitute or imply its endorsement, recommendation, or favoring by the U.S. Government or any agency thereof. The views and opinions of authors expressed herein do not necessarily state or reflect those of the U.S. Government or any agency thereof.



# **Installation of Halden Reactor Project Digital Interface Prototypes in the Human Systems Simulation Laboratory**

**OECD Halden Reactor Project**

**May 2013**

**Idaho National Laboratory  
Idaho Falls, Idaho 83415**

**<http://www.inl.gov>**

**Prepared for the  
U.S. Department of Energy  
Office of Nuclear Energy  
Under DOE Idaho Operations Office  
Contract DE-AC07-05ID14517**



## EXECUTIVE SUMMARY

The Office of Economic Cooperation and Development (OECD) Halden Reactor Project (HRP) features a state-of-the-art research simulator facility in Halden, Norway, dedicated to the development and validation of advanced control room concepts. The U.S. Department of Energy's (DOE) Light Water Reactor Sustainability (LWRS) Program has contracted HRP to assist DOE national laboratory staff in adapting HRP design concepts used in international control rooms for the purpose of control room modernization at nuclear power plants in the U.S. In support of this effort, the DOE has built a full-scope and full-scale simulator research facility at the Idaho National Laboratory centered on control room modernization, in which industry provided plant instrumentation and controls are modified for upgrade opportunities.

This report highlights HRP's historic developments in control room design, culminating in a number of innovative design concepts, including:

- Task-based displays,
- Ecological interface design,
- Function-oriented displays,
- Large screen displays, and
- Information rich design.

As documented in this report, HRP has successfully implemented examples of these design concepts at their simulator. In addition, such human-system interfaces have been brought to the LWRS simulator at the INL. First, the two current HRP simulator prototypes for boiling and pressurized water reactors have been deployed at the LWRS simulator facility at the INL. These simulators work through a server-client framework, in which the server is maintained at the HRP in Norway and the simulator client is run locally at the INL. This configuration allows DOE to explore simulator prototypes and direct design modifications as desired. Second, the HRP has interfaced its ProcSee simulator development platform to the Generic Pressurized Water Reactor (GPWR) found at the LWRS simulator. Using picture-in-picture technology on the simulator platform, HRP has demonstrated digital control system displays suitable for incorporation in hybrid analog-digital control room upgrades in the U.S.





## **DEDICATION**

Dedicated to the memory of Dr. Julius “J” Persensky, who was working on the preparation of this report at the time of his sudden death. We gratefully acknowledge J’s tireless support of Halden and the DOE simulator capability, including especially his mentoring of INL staff. Many of the ideas captured in this report would not have reached fruition without championing by J. He is greatly missed.



## **ACKNOWLEDGMENTS**

This report represents a compilation of ideas from OECD Halden Reactor Project, which have been tailored to reflect their applicability to the U.S. DOE's Light Water Reactor Sustainability Project. The lead authors at OECD Halden Reactor Project are Håkon Jokstad, Jon Øyen Hol, Thorbjørn J. Bjørlo, Alf Ove Braseth, Christer Nihlwing, Håkan Svengren, and Lars Hurlen, with additional contributions by Idaho National Laboratory staff, including Jeffrey Joe, Ronald Boring, David Gertman, and J. Persensky. Portions of this report have previously appeared as Halden Work Reports (HWRs).

This report was completed under contract 162067 from Battelle Energy Alliance (BEA) to the Institute for Energy Technology (IFE). Battelle Energy Alliance is the operating contractor of the Idaho National Laboratory for the U.S. Department of Energy. The Institute for Energy Technology is the parent organization for the OECD Halden Reactor Project.



# CONTENTS

EXECUTIVE SUMMARY .....	ii
DEDICATION .....	iv
ACKNOWLEDGMENTS .....	vi
ACRONYMS .....	1
1. INTRODUCTION .....	4
1.1 Purpose of Report .....	4
1.2 Background .....	4
1.3 Human Systems Simulation Laboratory .....	5
1.4 OECD Halden Reactor Project .....	5
1.5 Report Outline .....	7
2. ADVANCED CONTROL ROOMS AT OECD HALDEN REACTOR PROJECT .....	8
2.1 Background .....	8
2.2 Pre-HAMMLAB Period (1967 – 1983) .....	8
2.3 HAMMLAB (1983 – 1990) .....	8
2.4 HAMMLAB (1991 – 2001) .....	9
2.5 HAMMLAB (2001 – Present) .....	10
2.6 Development of User Interface Management Systems .....	11
2.7 HAMMLAB Today .....	13
3. HALDEN DESIGN INNOVATIONS .....	14
3.1 Background .....	14
3.2 Task-Based Displays .....	15
3.3 Ecological Interface Design .....	16
3.4 Function-Oriented Displays .....	17
3.5 Large Screen Displays .....	19
3.6 Information Rich Design .....	20
4. HALDEN APPLICATION FOR LWRS .....	24
4.1 Work Performed .....	24
4.2 Background and Familiarization with DOE's GPWR Simulator .....	24
4.3 Installation and Integration Testing at INL .....	24
4.4 Installation of Prototype Full-Scope HSIs .....	25
4.5 Results .....	26
5. CONCLUSIONS .....	28
6. REFERENCES .....	30

# FIGURES

Figure 1. The LWRS Full-Scope and Full-Scale Control Room Simulator.....	5
Figure 2. A Fully Digital Control Room for a Nuclear Power Plant at OECD Halden Reactor Project.....	6
Figure 3. Example Task-Based Displays. ....	16
Figure 4. Example Ecological Interface Display for a BWR.....	17
Figure 5. Example Function Overview Displays. ....	18
Figure 6. Large Screen Display from Snorre A Offshore Oil Platform. ....	19
Figure 7. Large Screen Overview for a PWR. ....	20
Figure 8. Example Information Rich Design Display.....	22
Figure 9. Remote Connection from the HSSL to the RIPS Server in Halden, Norway.....	25
Figure 10. Large Screen Display for RIPS (top) Adapted for LWRS Glasstop (bottom).....	29

## TABLE

Table 1. Attributes of Conventional and Advanced Control Rooms ..... 6

## ACRONYMS

A-PODIA	Advanced Plant Operation by Displayed Information and Automation
BEA	Battelle Energy Alliance
BWR	boiling water reactor
CAMPS	Computer systems Applying MicroProcessor Structures
COSS	Computerized Operator Support System
DCS	digital control system
DOE	Department of Energy
EdA	event-dependent assistance display
EFD	early fault detection
EID	ecological interface design
EPRI	Electrical Power Research Institute
FOD	function-oriented display
GPWR	Generic Pressurized Water Reactor
GUI	graphical user interface
HAMBO	HAMMLAB Boiling Water Reactor
HAMMLAB	Halden Man-Machine Laboratory
HRP	Halden Reactor Project
HSI	human-system interface
HSSL	Human Systems Simulation Laboratory
HWR	Halden Work Report
I&C	instrumentation and control
IFE	Institute for Energy Technology
INL	Idaho National Laboratory
IRD	information rich design
ISACS	Integrated Surveillance and Control System
LWRS	Light Water Reactor Sustainability
LSD	large screen display
MTO	Man, Technology, and Organization
NCT	Nord Colour Terminal
NPP	nuclear power plant
NRC	Nuclear Regulatory Commission
OECD	Office of Economic Cooperation and Development
OPCOM	Operator Communication
P&ID	pipng and instrumentation diagram
PPD	procedure performance display
PPC	plant protective computer
PSOD	procedure selection and overview display
PWR	pressurized water reactor
R&D	research and development
RIPS	Ringhals Integrated Process Simulator
SPDS	safety parameter display system
TBD	task-based displays
TCP/IP	Transmission Control Protocol/Internet Protocol
TMI	Three Mile Island
UIMS	user interface management system
UNIX	Uniplexed Information and Computing Service



U.S.  
VDU  
VR

United States  
video display unit  
virtual reality



# 1. INTRODUCTION

## 1.1 Purpose of Report

This report is for the Light Water Reactor Sustainability Program's (LWRS) Control Room Modernization Demonstration Project, and documents the installation of Office of Economic Cooperation and Development (OECD) Halden Reactor Project (HRP) digital interface prototypes in the LWRS simulator in the Human Systems Simulation Laboratory (HSSL) at Idaho National Laboratory (INL).

## 1.2 Background

Nuclear power has been an essential component to the United States' (U.S.) energy portfolio, providing 20-25% of the nation's base load electricity, and will likely continue in this role in the foreseeable future, since suitable carbon emissions free alternatives are not available at the scale needed to meet demand. Clearly, the operating life of the existing fleet of nuclear power plants needs to be extended. The U.S. Department of Energy's (DOE) LWRS program is designed to do precisely this. LWRS is a DOE and nuclear power industry collaboration that provides the technical bases for licensing and managing the long-term and economical operation of existing nuclear power plants (NPPs), thereby supporting the objectives of energy security and economic sustainability.

One strategic pathway or focus area for the LWRS research and development (R&D) program is on Advanced Instrumentation, Control, and Information Systems Technologies. This LWRS pathway helps ensure that new advanced instrumentation and control (I&C) technologies can be used to reliably and safely to operate NPPs by conducting the R&D needed to develop the prerequisite scientific knowledge and technical basis for implementing new I&C technologies in nuclear energy systems.

Given this focus, one main area of R&D for this pathway is control room modernization. Existing NPP control rooms have mostly analog I&C systems, which are becoming more difficult to maintain due to the limited availability of replacement parts. NPPs have been using digital I&C technologies as replacements, but have largely done so in a piecemeal manner (Joe et al., 2012) due to the technical, regulatory, and economic risks involved in larger scale modernization efforts. As such, one of the LWRS demonstration R&D projects at the INL is concentrating on mitigating the risks entailed with larger scale control room modernization efforts that the nuclear power industry faces. In the HSSL is the LWRS simulator, which is a reconfigurable full-scope and full-scale control room simulator that is used to develop and test advanced digital I&C concepts and technologies for larger scale implementation in existing NPPs (Boring et al., 2012 and 2013). The LWRS simulator provides a realistic but flexible test environment to evaluate and refine digital I&C technologies and newer human-system interface (HSI) approaches prior to their implementation in NPPs. This test bed allows the U.S. nuclear industry to evaluate how they can best use the enhanced capabilities of digital I&C systems to lower operational costs and improve plant performance while minimizing disruptions to their operations and training schedules. As part of the LWRS program, findings on plant control room modernization experience are disseminated across the industry to ensure maximum applicability.

### 1.3 Human Systems Simulation Laboratory

The HSSL at the INL houses the LWRS simulator, which is a reconfigurable full-scale and full-scope control room simulator (Boring et al., 2013). Consisting of 45 large touchscreens on 15 panels, the LWRS simulator is currently using this glass top technology to digitally represent and replicate the functionality of the analog I&C systems in existing control rooms (see Figure 1). The LWRS simulator is reconfigurable in that different plant training simulator models obtained from the utilities can be run on the panels, and the panels can be physically moved and arranged to mimic the layout of those control rooms. The glass top technology and reconfigurability capabilities allow the LWRS simulator to be the research platform that is necessary to design, prototype, and validate HSI technologies that can replace existing analog I&C.



**Figure 1. The LWRS Full-Scope and Full-Scale Control Room Simulator.**

To date the LWRS simulator has been used to help modernize two U.S. NPP control rooms. The success of this work has provided initial validation that the LWRS simulator can serve as a standard test bed for control room modernization across the nuclear industry. The virtual representation of the entire control room has provided a cost-effective platform for utilities to design, prototype, and validate replacement HSI technologies without (1) having to physically build another control room simulator, (2) risking noncompliance with their operating license by creating variances between their actual control room and their training simulator, or (3) impacting the training schedules at their existing simulator. The virtual representation of the I&C has also meant they can be modified more easily than in available plant training simulators, since none of the I&C is physically hardwired into the panels. As a facility that can provide a systematic and rigorous platform to conducting HFE and I&C research, the LWRS simulator facility addresses an immediate industry need by supporting control room modernization activities, and can be an equally useful tool in supporting future plant-wide modernizations.

### 1.4 OECD Halden Reactor Project

The HRP in Halden, Norway, includes a state-of-the-art research simulator for control room design. Halden Reactor Project has developed and validated a number of control room principles applicable to the modern, fully digital control room (see Figure 2). These include optimized workstation displays, large overview displays, computer-based procedures, and automated systems.



Figure 2. A Fully Digital Control Room for a Nuclear Power Plant at OECD Halden Reactor Project.

Table 1. Attributes of Conventional and Advanced Control Rooms

<b>Attribute</b>	<b>Conventional Control Room</b>	<b>Advanced Control Room</b>
<i>I&amp;C</i>	Analog	Digital
<i>Controls</i>	Manual Hard Controls	Manual Soft Controls and Automated Controls
<i>Computers</i>	Separate Plant Process Computer (PPC), Safety Parameter Display System (SPDS), and Digital Control System (DCS)	Integrated platform with digital controls and displays
<i>Operation</i>	Standing at Control Boards	Sitting at Workstations
<i>Procedures</i>	Paper	Computer-Based
<i>Alarms</i>	Annunciator Tiles	Prioritized Alarm Lists and Embedded Alarms in Interactive Piping and Instrumentation Diagrams (P&ID)
<i>Implementation</i>	Current U.S. NPPs	Current Process Control Rooms, Some Current International NPPs, and Future U.S. and International NPPs

Table 1 depicts the attributes of conventional and advanced control rooms. The capabilities of conventional control rooms reflect the functions modeled in the LWRS glass top simulator at the INL. The capabilities of advanced control rooms reflect the types of HSI functionality found in the research simulator at the HRP. The differences between conventional and advanced control rooms are substantial, and HRP has been enlisted to help bridge these gaps. Whereas most currently scoped control room modernization efforts in the U.S. feature gradual introduction of digital control system (DCS) displays into the control boards, the control room at HRP completely omits control boards in favor of operator workstations and large overview displays. While the upgrade path of U.S. control rooms at NPPs may not feature any immediate plans to abandon the control boards, the introduction of digital technology affords

the opportunity to use ideas from advanced control rooms to improve the overall HSI. For this reason, the LWRS Program is enlisting HRP to adapt concepts from their experience with digital control rooms to support control room modernization in the U.S.

## **1.5 Report Outline**

This report describes efforts to date to install advanced control room HSIs by HRP at the LWRS reconfigurable simulator at the INL. The description begins in Chapter 2 with a review of the various control rooms developed at HRP. In Chapter 3, we discuss the types of HSI innovations that have been developed at HRP and that are important building blocks for advanced control rooms. Chapter 4 provides an account of the installation of HRP HSIs at the LWRS control room simulator. Finally, Chapter 5 concludes this report with a discussion of planned future work.

## **2. ADVANCED CONTROL ROOMS AT OECD HALDEN REACTOR PROJECT**

### **2.1 Background**

The Institute for Energy Technology (IFE) operates the HRP in Halden, Norway. Established in 1948 with an original aim to develop and build research reactors in Norway, the HRP conducts research for the nuclear energy industry on both (1) fuels and materials, and (2) human factors, which is called the Man, Technology, Organization (MTO) program. The HRP has over 40 years of experience conducting research in HSI design and in the safe and effective operation of nuclear power plants using various research simulators, such as the Halden Man-Machine Laboratory (HAMMLAB).

### **2.2 Pre-HAMMLAB Period (1967 – 1983)**

In 1967, the members of the HRP decided that a new research program, the so-called computer control program, should be initiated. The establishment of this program reflected the rapid development in the computer field in the 1960s. The first attempts to introduce computers in process supervision and control were initiated, and computer vendors started to market special computers for process control, while analog technology was still dominant within this field. The HRP proposed a research program for exploring the potential of this emerging digital technology for supervision and control within the nuclear field, as well as for collection and storage of measurement data from the fuel experiments in the Halden reactor (Pettersen, 1971).

Through this experimentation the feasibility of process computers for the supervision and control of the Halden reactor was demonstrated. This led to the idea of a full-scale demonstration of this concept, supervision and control of the reactor from a fully computerized control room. The OPCOM (OPERATOR COMMUNICATION) project was started where an experimental, fully computerized control room was built-up in a room adjacent to the conventional control room. The aim of this project was to demonstrate that the Halden research reactor could be controlled and operated from a computerized control room through a specially designed operator's console and color-TV screens (Netland & Hol, 1977). From 1973-75 the Halden reactor was operated continuously from the OPCOM control room in experiments manned by regular 8-hour shift crews, with the conventional control room in hot stand-by. These experiments duly demonstrated the possibility of operating the reactor from a computerized control room (Netland & Lunde, 1975).

### **2.3 HAMMLAB (1983 – 1990)**

The Three Mile Island (TMI) accident in 1979 further spurred the development of the MTO program. TMI clearly showed that poor information design in the control room was an important factor in the initiation and progression of the accident. This resulted in a markedly increased interest in the work at the HRP in control room design, including the use of digital technology and computer screen based information displays. The work done in the OPCOM project represented pioneering work in the nuclear community with respect to utilizing human factors studies in a systematic way to improve operator performance. After TMI, the safety authorities regarded this as a prioritized field to improve the safety of nuclear power plants, and safety work shifted focus from mostly being concerned with technological safety barriers to also include the human operator. It soon became clear that the increased emphasis on

operator communication studies and human factors issues in the joint program of the HRP following TMI required new laboratory facilities. This was the initial reason for building HAMMLAB, which was based on a full scope simulator of a NPP (Stokke, 1981).

In the 1980s, most of the human factors research in HAMMLAB was focused on development and evaluation of Computerized Operator Support Systems (COSSs). The COSSs developed were integrated in the HAMMLAB operator communication system, and were evaluated in comparative experiments where operators from the Halden reactor were test subjects. In these experiments the performance of the operators was observed during plant disturbances with and without access to the COSS to measure the effect of the COSS on the operators' ability to handle the situation.

Most of the COSSs implemented and tested in HAMMLAB were systems aimed at assisting the operators in detecting and diagnosing abnormal plant behavior. The TMI accident had revealed that conventional alarm systems had serious shortcomings during accident sequences due to the large number of alarms created (Kemeny, 1979). In HAMMLAB, experiments with different alarm systems aimed at improving this situation were conducted (Baker et al., 1985; Reiersen et al., 1987). The TMI accident also showed that instruments providing information of importance for assessing reactor safety were scattered around the control room (Kemeny, 1979). Consequently, the U.S. Nuclear Regulatory Commission (NRC) required reactor vendors to develop and implement a Safety Parameter Display System (SPDS) in the reactor control room, which were developed and tested by the HRP and a partner nuclear power utility and vendor (Marshall et al., 1983; Hollnagel et al., 1984).

## **2.4 HAMMLAB (1991 – 2001)**

In 1991, HAMMLAB was moved to another building, and a new, more spacious laboratory was constructed, including a new experimental control room and experimenters' gallery. This was done to address the MTO program's broadened research scope, which included the development and evaluation of experimental control rooms. In 1991, the first prototype of the Integrated Surveillance and Control System (ISACS), which integrated the information from the process and a set of COSSs, was installed in HAMMLAB, and development and evaluation of this concept became a major effort in HAMMLAB in this period (Haugset et al., 1990; Førdestrømmen et al., 1991; Follesø & Volden, 1992; Follesø & Volden, 1993a). Another trend in the 1990s was a shift to more basic human factors experiments, including the development and utilization of new methods and measures to investigate operator behavior, with emphasis on improved understanding of how and why cognitive errors occur (Follesø & Volden, 1993b; Kaarstad, 1995; Skranning, 1998; Collier & Andresen, 2000; Andresen & Drøivoldsmo, 2000). More basic human factors programs in this period included situation awareness studies (Hogg et al., 1994; Drøivoldsmo et al., 1998), human error analysis projects (Kaarstad et al., 1998; Follesø et al., 1996; Wioland et al., 2000), and studies of the influence of task complexity on problem solving (Braarud, 1998; Braarud, 2000).

Another major development connected to HAMMLAB was the initiation of research in the Virtual Reality (VR) field from 1996 (Louka & Beere, 1998; Lirvall, 1998; Louka, 1999). The introduction of this technology opened new possibilities in design, training and work planning. The work in the 1990s mostly addressed establishment of the necessary tools and infrastructure, but some industrial projects were also carried out.

The change in focus in the 1990s towards more integrated control room studies and human factors analyses reflected in many ways the needs of the nuclear industry. The control rooms of many of the older nuclear power plants needed upgrading, and in this process new digital equipment was replacing some of the old analog control and instrumentation systems. Graphical User Interfaces (GUIs) were also taken into



use for information presentation in the control rooms. In new reactors under construction, mainly in Asia, more advanced control rooms, with digital instrumentation and screen based information systems, were introduced, such as the Advanced Plant Operation by Displayed Information and Automation (A-PODIA). There was concern, both among safety authorities and the power utilities themselves, with respect to the effect of this new technology on operator performance. More knowledge of how these changes in the control rooms affected the operators' role and tasks and their performance was therefore needed.

In addition, more emphasis in the 1990s was placed on developing methods and systems that did not only address the operator, but also maintenance and optimization of the plant. New methods for signal validation and fault detection based on neural networks and fuzzy logic techniques were explored (Fantoni et al., 1998; Fantoni et al., 1999; Roverso, 1998; Roverso, 1999), and model-based fault detection methods which had been used to develop the Early Fault Detection (EFD) system in the 1980s were taken into use in model-based condition monitoring for plant maintenance optimization (Lund et al., 1996) and in the thermal power monitoring and optimization project (Sunde & Berg, 1998; Sunde et al., 2002). Further, a large project to develop a support system for both the control room, the Technical Support Centre and National Safety Authorities in managing accident conditions was carried out (Fantoni et al., 1994; Berglund et al., 1995; Fantoni et al., 1996).

## **2.5 HAMMLAB (2001 – Present)**

Towards the end of the 1990s it became clear that HAMMLAB simulator could not meet the future needs of the member organizations of the HRP regarding control room and human factors studies. A project was launched to establish new laboratory facilities for both HAMMLAB and the VR Centre with new full-scale NPP simulators that were more representative for the NPPs in most member countries (Kvalem et al., 1996; Fält et al., 1998a; Fält et al., 1998b; Jokstad et al., 1988). In 2000 the HAMmlab BOiling (HAMBO) water reactor simulator was installed (Karlsson et al., 2001; Sørenssen et al., 1999). A simulator to serve the petroleum industry was integrated (Haukenes et al., 2001). PCs were also replacing UNIX stations as the main platform for the HAMMLAB systems.

These major investments in HAMMLAB upgrades reflected the importance placed on control room studies. Life extension programs within the nuclear industry accelerated the trend towards replacing old control rooms with new digitally based solutions. Better knowledge of the impact of these new solutions on operator performance was still needed, and could be obtained from controlled experiments in HAMMLAB. New screen-based control rooms also opened possibilities for alternative ways of presenting information to the operator to enhance their process understanding. In the joint program, research on innovative HSIs became a major activity, and task-based (Førdestrømmen, 2004; Svengren & Strand, 2005; Strand et al., 2007), function-oriented (Andresen et al., 2004; Andresen et al., 2005a; Andresen et al., 2005b) and ecological displays were studied (Welch et al., 2007; Skraaning et al., 2007; Lau et al., 2008; Burns et al., 2008). The research on new and innovative HSIs resulted in the development of a new concept for display design, named Information Rich Design (IRD, Welch et al., 2004). This novel HSI design method aims at replacing the traditional P&ID-based designs with visual forms that are easily perceived and interpreted, enabling the operators to obtain key information at a glance. There was also concern that the increasing automation could lead to so-called “out-of-the-loop performance problems” for the operators and experiments with different procedure automation levels were conducted to study this effect (Massaiu et al., 2004). Further, experiments to provide human reliability data for verification of human reliability models became an important activity in this period (Collier, 2005; Lois et al., 2008a; Lois et al., 2008b; Parry et al., 2008).

Many industry projects in this period also focused on control room design and evaluation. A prototype of an outage information system consisting of a large screen overview display was developed to support operators during outages (Svengren & Meyer, 2005). Projects to develop and test new, more flexible alarm systems experimentally to find “best-practices” of alarm systems were also carried out (Karlsson et al., 2002). User tests with nuclear power plant crews were performed and resulted in advice for upgrades of the existing alarm systems.

Further, large integrated system validation projects were carried out in connection with control room modernization (Gunnarsson & Farbrot, 2004). Integrated system validation is an acceptance test of new or upgraded control rooms regarding human factors for the operators (for the nuclear industry, the design review process is described in (O’Hara et al., 2004). Both verification against guidelines and requirements during the design process, and validation of the end result, are important parts of this process. Many methods developed in HAMMLAB have proven of great use for validation of the final control room. The tests have so far mainly utilized an approach with benchmark validation in simulators (Braarud & Skraning, 2007). In a benchmark validation, the human performance in the new control room is compared to human performance in the old control room (O’Hara et al., 1997), and the requirement often set is that the new control room shall be at least as good as the old one. Many issues around the design of these studies as well as the performance measures have been directly taken from the experience in HAMMLAB, (e.g., operator performance measures on task performance, situation awareness and workload; Braarud & Skraaning, 2006).

## **2.6 Development of User Interface Management Systems**

It became evident right from the start of the research on the OPCOM operator communication system at Halden (Netland & Hol, 1977) that in-house development of hardware/software systems for the user interface was necessary to achieve flexibility in the design of displays and operator interaction systems. This philosophy has been a leading principle for research at the HRP up to present days, and has been a major factor for the success of human factors research. Specifically, in-house expertise in the development of user interface management systems (UIMS) has made it possible to quickly and economically adapt to the requirements to new and innovative user interface solutions suggested by the human factors and display design specialists. The continuous development of UIMS tools at the HRP has resulted in products of high industrial standard, widely used in different industries.

The first 15 years, starting with the OPCOM project, the work on GUIs comprised both hardware and software development and was based on proprietary hardware. In the first versions of GUIs developed at the HRP, the screen graphics were mostly coded from scratch, but in the last part of the 1970s dynamic editors were developed with support from industry to ease the production of graphical user interfaces. When HAMMLAB was established in 1983 the operator communication system in the control room was based on Nord Colour Terminals (NCTs), and the displays and operator interaction systems were developed by HRP staff. The next step in the development of UIMS was the development of the Computer systems Applying MicroProcessor Structures (CAMPS) graphic station (Sundling & Arnesen, 1985). CAMPS is a powerful, but inexpensive and highly flexible, microcomputer structure incorporating a high resolution graphic controller. In connection with the development of CAMPS, the first version of the Picasso system, Picasso-1, was developed. It consisted mainly of a graphics command language, and an interpreter, which used instructions written in this language combined with dynamic data as input, and as output sent graphics commands to the CAMPS unit for display. Picasso-1 was then extended with a graphics editor that made it possible for non-computer experts to develop process formats interactively. Picasso-1 was quickly adopted in HAMMLAB, and was eventually used to develop the operator interface for the core surveillance system at an operating nuclear power plant in Sweden (Aaser et al., 1985).

When the HRP switched to using UNIX workstations rather than continuing development of proprietary hardware, it triggered the development of the second generation of the Picasso system, Picasso-2 (Hornæs et al., 1988; Hornæs et al., 1990). UNIX workstations had started to use standard graphics interface packages. Picasso-2 was adapted to this de-facto industry standard (X-Windows) as well as the Transmission Control Protocol/Internet Protocol (TCP/IP) protocol for data communication. In this way Picasso-2 became effectively hardware independent. During the next years, Picasso-2 was continuously developed and improved through a number of bilateral industry projects. In the period 1992-2002 Picasso-2 was used in a large number of projects for the petroleum industry, nuclear power plants, electrical grid supervision, and maritime applications.

The need for more flexibility, and an easier way to implement displays, led to the development of a third generation of Picasso (Barmsnes et al., 1991a; Barmsnes et al., 1991b). Picasso-3 was a software product of high industrial standard in that it had version control, formalized test procedures, extensive user documentation, and an e-mail based user support service. In addition, user-group meetings were arranged at regular intervals, and improved versions were issued regularly. These features made Picasso-3 comparable to other commercial software products, and this required guidelines different from the ordinary rules for dissemination of results from the research work at the HRP. Thus, IFE was granted the right to market Picasso in the member countries, and companies taking Picasso in use could integrate it in their own products and market these worldwide. However, no user of Picasso could be granted exclusive rights to its use. Picasso-3 has become the most successful software product developed at the Halden Project. It has been taken into use in different industries. Over the years it has been steadily improved. Major developments have been: a new data communication system, the software bus in 1996, porting to Microsoft Windows platform in 1998, Linux version in 1999, support for Microsoft COM components and ActiveX controls in 2003, and support for OPCOM in 2005. Use of Picasso-3 on portable, handheld devices has also been tested and found feasible in 2007.

In 2005 it was decided to rename Picasso-3. The new name chosen was ProcSee, symbolizing the combination of process and visualization (Randem et al., 2005). The motivation for changing name was mainly to avoid a potential conflict concerning the name Picasso. ProcSee is now registered as a trademark for the product. The main application areas have been on-line process supervision and control, nuclear and fossil power plant simulators, maritime applications, and emulation of control systems (in simulators). Examples of actual systems that have been developed with ProcSee include:

- Core surveillance systems and plant monitoring systems for NPP control room operators (e.g., SPDS)
- Process surveillance systems and systems to monitor process data
- Metering systems for oil and gas production worldwide
- Supervisory and control systems for power grids
- Supervisory and control systems for electric power production balance

ProcSee/Picasso has also been utilized in a large number of fossil and nuclear power plant simulators. The NRC has used ProcSee for GUI development in 4 NPP training simulators at their training center. Many others have used ProcSee as GUI tool in the development of several different engineering and training simulators for nuclear power, petroleum, maritime, and military applications.

In summary, while it is clear that the development of UIMS at the HRP have been used in numerous mission critical settings, and have had a significant impact on a variety of industries, this activity has also been a significant factor in the success of the R&D that has been performed in HAMMLAB. The availability of in-house GUI tools and expertise has been very important for the development of the HAMMLAB simulators and for design and implementation of human factors experimental programs.

## 2.7 HAMMLAB Today

HAMMLAB serves two main purposes: the study of human behavior in interaction with complex process systems; and the development, test, and evaluation of prototype control centers and their individual systems. The aim of HAMMLAB is to extend the knowledge of human performance in complex process environments, in order to adapt new technology to the needs of the human operator. By studying operator performance in HAMMLAB and integrating the knowledge gained into new designs, the operational safety, reliability, efficiency, and productivity can be improved.

HAMMLAB includes two nuclear power plant simulators and a modern, computer-based, highly configurable experimental control room with extensive features for studying operator crew performance. HAMMLAB's two full-scope nuclear power plant simulators, named HAMBO and the Ringhals Integrated Process Simulator (RIPS), represent a Swedish boiling water reactor (BWR) plant (Forsmark Unit 3) and a typical Westinghouse 3-loop pressurized water reactor (PWR) plant (Ringhals Unit 3), respectively.

One major success factor of the HRP has without doubt been its ability to transfer the results of the research at Halden into practical, industrial applications in the member countries. The integration of HAMBO and RIPS into the LWRS simulator ensures that the advanced HSI technologies found in those simulators can be disseminated to support control room modernization at U.S. plants.

## 3. HALDEN DESIGN INNOVATIONS

### 3.1 Background

The goal of the HRP is to provide the nuclear industry with knowledge and ideas for improving information presentation in hybrid analog-digital or fully digital, computerized control rooms. This goal is being met by designing prototypes which is implemented in full-scope nuclear simulators, evaluating them in user tests and larger-scale experiments in HAMMLAB, and providing lessons learned, design recommendations and technical bases for guidelines to the industry.

This chapter addresses challenges of computerized interfaces, and how lessons learned from the HSI research of the HRP contributes to solving some of these challenges. The present generation of computerized interfaces within the nuclear industry is more or less screen-based replicas of the traditional mimic-based hard-paneled interfaces. Although a natural first step, this approach introduces new challenges from a human factors perspective. It also fails to take advantage of the new possibilities the new digital medium offers.

Some of the known challenges with present computerized HSIs are:

- *The keyhole effect:* In traditional control rooms the interface covers a large part of the room's walls and desks. In computerized environments the operator's interface is located on a number of computer screens. The result is that operators often lose overview of the complete process. The interface fails to support the behavior of "stepping back" to get the "big picture," focusing exclusively on smaller parts of the process, screen by screen, as through a keyhole (Woods et al., 1990).
- *Interface management issues:* As the interface is distributed over many displays limited in size, operators will have to navigate through them to access the information they are looking for. The display shown on each screen is chosen by the operator, e.g. mimic-based displays, trends, alarm systems, etc. While this flexibility offers some advantages, studies have shown that operators often get lost, experiencing a hard time managing screens and finding the information they are particularly looking for and thus reducing operator performance (O'Hara and Brown, 2002).
- *Visual patterns disappear:* Key features of traditional panel-based control rooms are analog display elements spatially distributed throughout the room (e.g., analog meters, tile-based alarms with a single lamp representing a single alarm, etc.). These and other analog display units seem to better support fast recognition of overall process status than is the case in their computerized counterparts. Four arrows pointing at 12 o'clock and a number of alarm tiles lighting up in different places in the control room (often with sounding alarms coming from different locations as well) are more rapidly and accurately interpreted than mere numbers and lines of text appearing on a screen.
- *Teamwork transparency:* In a traditional control room it is easy for operators and the shift supervisor to see what others are doing. As every element in the interface has a fixed location operators may conclude with a certain accuracy what colleagues are doing simply by noticing where they are in the control room. In contrast, in most computerized environments, the actions of others are often not that evident. Operators are located at desks, acting on displays that are not easy to read from a distance. This reduces each team member's awareness of others' actions, making coordination more difficult (Easter, 1991; Stubler and O'Hara, 1996).

The HSI research performed at the HRP in recent years has sought to address these challenges while at the same time exploring new opportunities offered by computerized interfaces. Digital control systems and presentation media are highly flexible, making it possible to design information in any way one thinks is beneficial, not limited by physical constraints. Information can be synthesized to more

effectively convey the current status of a system function and its availability for control by the main control room. The digital HSI can also be shaped to better support early detection of deviating system states, grabbing the operator's attention and supporting the inspection of detailed information while keeping the overall perspective.

This has led the HRP to develop and test a number of novel interface concepts presented on media ranging from workstation screens to large screens, and even ultra-large screens (up to 16 meters wide). Through various lessons learned the HRP is confident that as computerized HSIs mature, one will be able to merge the qualities of the old-fashioned interfaces with the opportunities of the new technology to overcome the above challenges and to further enhance human performance and reduce the risk of error.

The HAMMLAB in its various guises has become a reference facility for human factors studies and for control room design. Over the years, the HAMMLAB has been continually updated and has provided the environment for developing and testing advanced display concepts. This chapter will discuss a few of the innovations that are particularly relevant to NPP control rooms. These include:

- Task-based displays (TBD),
- Ecological interface design (EID),
- Function-oriented displays (FODs),
- Large screen displays (LSDs), and
- Information rich design (IRD).

These concepts were previously demonstrated at the LWRS-sponsored Alarm Design Workshop (Boring, 2011). Each of these will be addressed in separate sections in the remainder of this chapter.

## 3.2 Task-Based Displays

The main idea of the task-based approach is to design displays that provide operators with all information needed to perform a certain pre-defined task as effectively and safely as possible. Initial work indicated that procedure-based tasks were particularly suited for such an approach, and later work aimed at studying how emergency operating procedures can be fully integrated with process displays to enhance operator performance.

Three different kinds of TBDs have developed for a BWR simulator in HAMMLAB. The three types of displays complement each other, and together they constitute the "Task-based display concept": the Procedure Selection and Overview Display (PSOD), the Procedure Performance Display (PPD), and the Event-dependent Assistance Display (EdA). The three display types and their location relative to each other are shown in Figure 3.

In the TBDs, the procedures are selected in the PSOD picture, and the corresponding PPD and EdA displays appear. The PPD is applied for executing the selected procedure. The EdA display contains information about the most important parameters and components relevant for the actual situation and event, and the information presented on this display thus depends on the selected procedure and the overall situation. All displays are continuously updated on the basis of actuated safety systems and procedure status.

When executing procedures, it is necessary for the operators to perform regular checks of the most important parameters and components relevant for the actual situation and event. The intention of the EdA display is thus to make the most important procedure-relevant information available to the operators

and to ensure that this information is located physically close to the procedure displays. The information in the EdA display depends on the selected procedure and the overall situation.

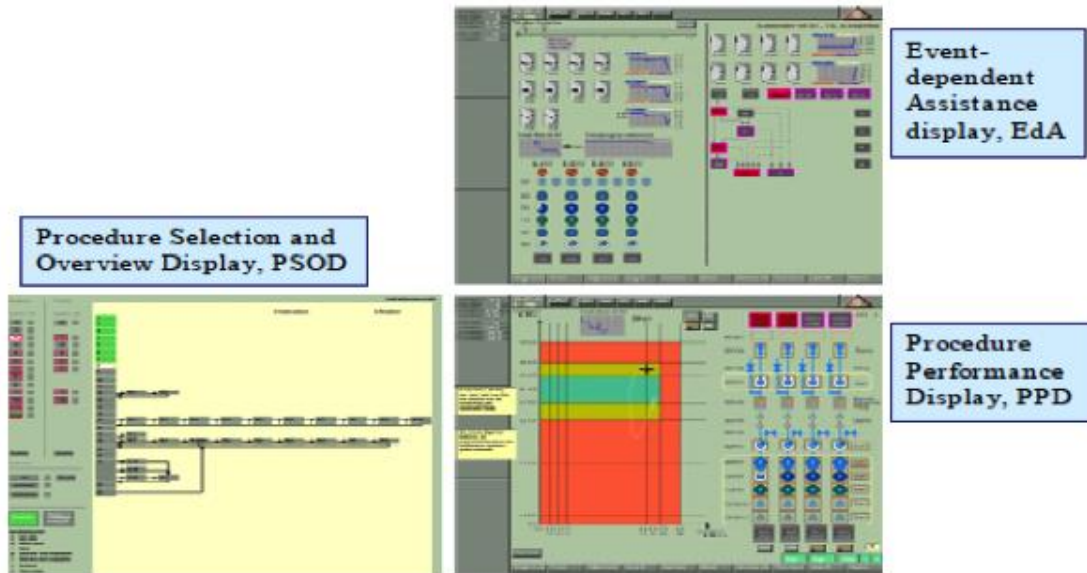

Figure 3. Example Task-Based Displays.

### 3.3 Ecological Interface Design

EID research at HRP has aimed at guiding the development of user interfaces that support rapid perception and correct interpretation of process data, especially when dealing with abnormal and/or unfamiliar conditions. Research on smaller scale processes has indicated that EID leads to innovative new designs with the ability to improve operator performance and situation awareness in such potentially hazardous situations. The HAMMLAB EID implementation aimed to study the impact of ecological interfaces on operator performance in a full-size process, gain experience with a large-scale design and document the design process itself. The EID project was carried out in close cooperation with the Canadian universities of Toronto and Waterloo.

Prototypes of a few ecological displays were implemented on the BWR simulator in HAMMLAB. A proper Cognitive Work Analysis, which is an important part of the EID process, was completed prior to design and implementation of the displays. Five displays were designed and implemented, covering the turbines, the condenser, the seawater system, the feedwater system, and the generator of the secondary side of the process (Welch et al., 2007).

In Figure 4 one example is given of the condenser and feedwater EID display, where some prominent features of the EID design is given, e.g. mass flow balance, temperature profiles, pump curves etc.

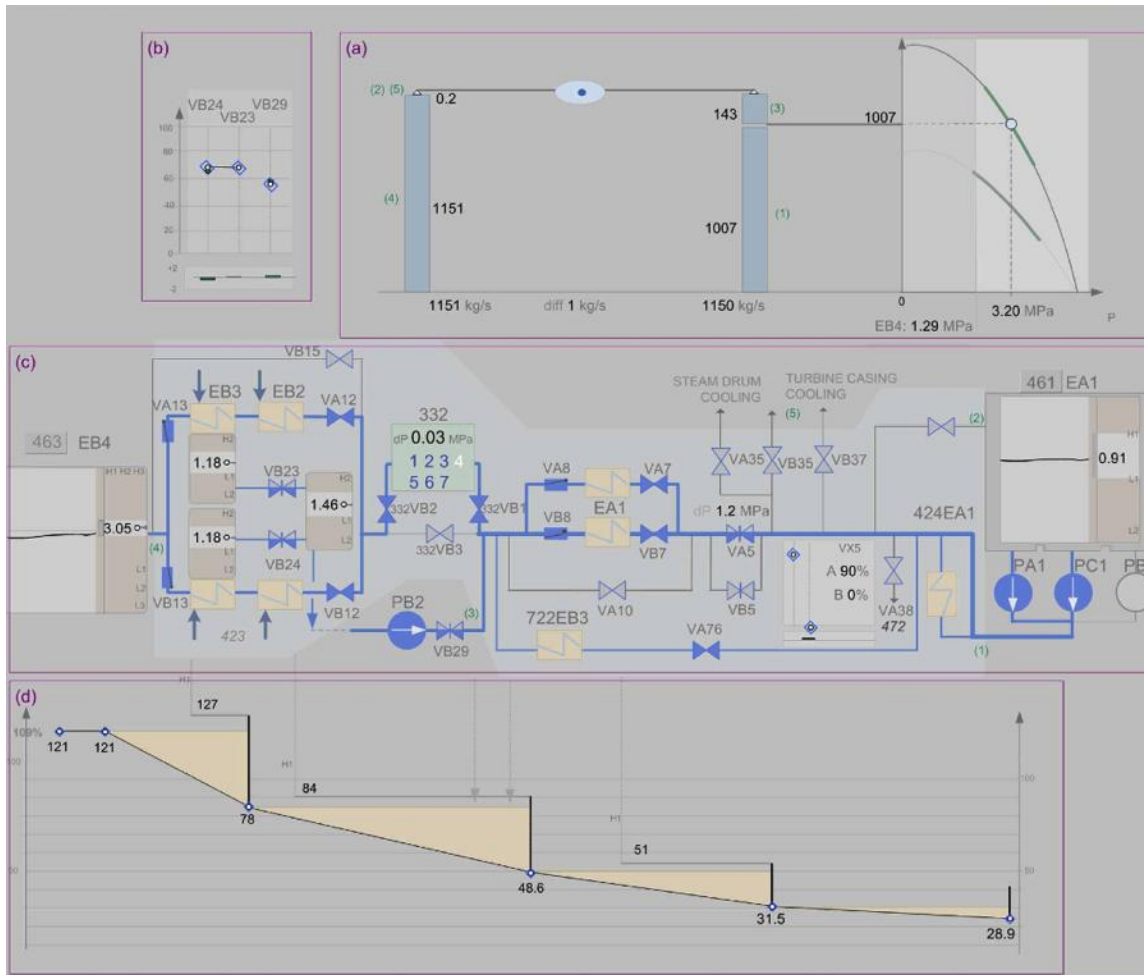

Figure 4. Example Ecological Interface Display for a BWR.

### 3.4 Function-Oriented Displays

FODs use a function analysis of the plant as the backbone for designing an integrated computerized HSI. It is quite common to use function analysis to define information requirements for HSI design, it is for instance recommended by NUREG-0711, so this is not a unique characteristic of FODs. The uniqueness of FODs is the way functions are explicitly represented through the displays and the way all parts of the HSI are designed from the same functional perspective.

A function-oriented HSI prototype has been implemented on the PWR simulator in HAMMLAB (Andresen and Pirus, 2005). The prototype covers the feedwater and steam generator functions and includes three display types: process displays, trend displays, and computerized procedures. The function-oriented displays differ from traditional process mimic displays in that components and systems are organized according to functions identified through a function analysis.

The function analysis begins with the top-level goals or plant missions and then decomposes the plant into functions and sub-functions. The sub-functions are identified by asking how a function is achieved; functions are identified by asking why a sub-function is performed. At the highest level of the decomposition, the plant is divided into functional sets. The number of functional sets may vary from



plant to plant. In the FOD project, the work initially focused on two functional sets: feedwater function and steam-production function.

Halden's FOD research has culminated in a series of process overview displays for a BWR as shown in Figure 5. To obtain a fast overview of the plant status in the control room, circles are used with sectors showing all steps in the procedure for running the plant from cold shutdown to full power. The four circles show the status of the reactor, the condenser, the turbine and the power operating mode of the plant. Power operating mode means that the plant is operating in the area from 50% to full power with all 8 internal core cooling pumps in automatic mode. In this case all circles are blue as shown in Figure 5 below.

Each circle shows the status of a part of the plant as described above, and the sectors contain a number of logical expressions that needs to be TRUE, FALSE or ignored to make the sector blue or green. If some expression in one sector is TRUE and another is FALSE, the sector will be grey and the operator can select the actual sector to see the detailed reason why it is grey. That some expressions can have status ignored under certain conditions means that the status of the expression is just not of importance in certain plant statuses.

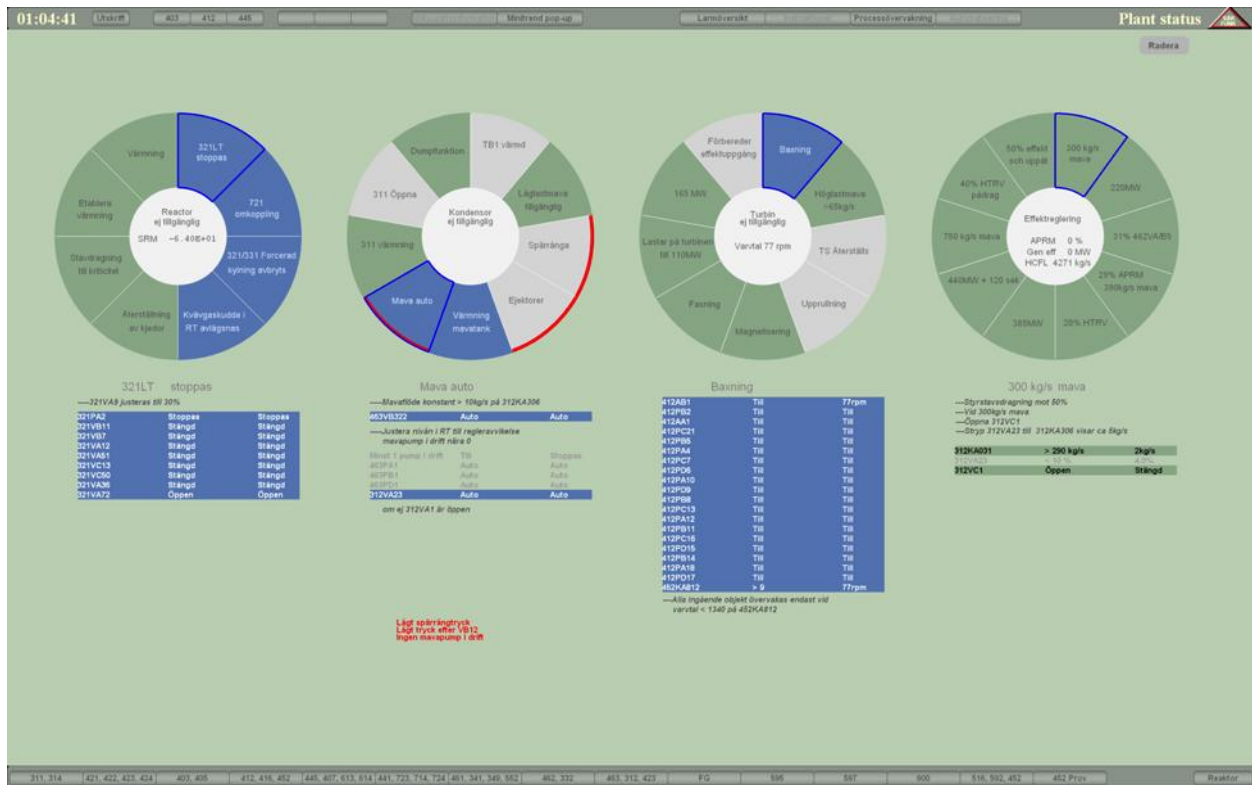

Figure 5. Example Function Overview Displays.

### 3.5 Large Screen Displays

LSDs can also be referred to as “group view displays,” whereby these interfaces are typically designed to support shared situation awareness in the main control room. HRP has done extensive work on such displays over a number of years ranging from small overview displays to ultra-large ones. Currently, HRP’s experience in this field is put into practice in various industries ranging from the oil and gas industry, to paper manufacturing, power grid operations, as well as the nuclear industry. These industries are all making the shift from traditional analog control systems to computerized ones, increasingly experiencing the need for shared overview information. Figure 6 shows an example full-wall LSD for oil production at a Norwegian offshore oil platform. Figure 7 provides an example of a PWR LSD developed for the PWR simulator used in HRP’s experimental facility. The design is inspired by traditional P&IDs and is a typical representation of today’s design scheme.



Figure 6. Large Screen Display from Snorre A Offshore Oil Platform.

The different large-screen display concepts that have been explored have many common characteristics:

- *Visual patterns for efficient recognition.* The IRD concept (see Section 3.6) and other “advanced displays” have explored the potential for synthesizing information into visual forms supporting pattern recognition, especially for early detection of deviating plant states.
- *Layered colour scheme:* Colours are chosen to form differentiable layers of information (background/static layer, focus layer and alarm layer) to effectively convey large amounts of information and direct attention.

- *Dedicated zones supporting different tasks.* An LSD may have a layout supporting different operator tasks in different places, either for different plant states, different types of work or roles. Examples are process overview zones, alarm zones, and safety zones.

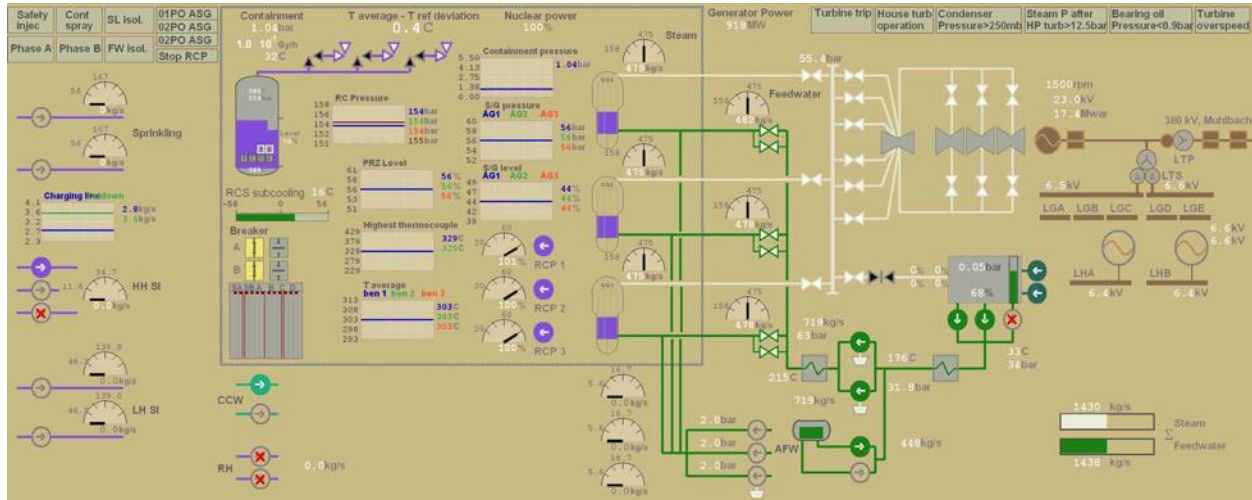

Figure 7. Large Screen Overview for a PWR.

### 3.6 Information Rich Design

The purpose of IRD is to condense existing information in process displays in such a way that each display picture contains more relevant information for the user. Compared to traditional process control displays, this design concept allows the operator to attain key information at a glance and at the same time allows for improved monitoring of larger portions of the process. This again allows for reduced navigation between both process and trend displays and eases the cognitive demand on the operator. The concept is based on weighing and classifying the relevance of types of information presented to users. By using well-proven principles from graphical design it visualizes this information in a manner that reflects its relevance. The IRD concept can supplement and complement other design concepts that are innovative in terms of their information content and/or visual form.

The concept was originally created for the operation of offshore petroleum production facilities. An offshore control room operator has to deal with a complex process where there is little redundancy in the main process functions. Due to the nature of the process medium, potentially hazardous situations may arise if safety constraints are not respected. Therefore there is focus on early detection and handling of abnormal conditions and events that may affect both production and safety. A new approach to offshore display design is necessary due to shortcomings in current designs. The keyhole effect is one important cause of these problems, as each display only reveals a fraction of the whole process. The IRD concept should also be relevant and easily applicable to other industries where the detection of incipient abnormal events may be critical to maintaining production and safety, such as the nuclear industry.

The information content and amount being presented to the operator in a display should be viewed in context of the wide range of different roles the operator is likely to have when using the display. For instance, an operator in a highly stressful situation with high workload within a limited amount of time should not have to deal with large amounts of information that is not relevant to that situation.

A user working with a lot of information that is badly displayed will often use a lot of mental effort on memorization and calculation. In addition to being time-consuming, these tasks are cognitively complicated and therefore greatly affect the work the user is able to do with traditional designs. This means that traditional displays can confine the way the user works and therefore limit what he/she is capable of.

In the last few years a new way of considering information visualization has emerged. In this new method, the role of the designer changes quite dramatically from merely taking an existing display and “upgrading” it by enhancing usability and other factors, to looking behind existing display concepts and considering what information the user actually needs. This information should then be presented in a manner that supports both existing and new ways in which the user can understand and use the information. This new approach has been labeled “User Enabling,” and aims to allow the user to develop and use entirely new strategies for how to work.

Both the content and visualization of content in today’s video display units (VDUs) include several shortcomings. Displays only reveal a fraction of the total process; this is often referred to as the keyhole effect. Operators struggle to get a complete understanding of the state of the process; an often-heard statement from operators is “I need more VDUs to get a good overview.” In addition, the work domain and work style will probably also change in the future due to the introduction of larger operation centers, where operators may have to operate several processes in parallel. By introducing parallel processes the operator’s mental capacity is challenged and one can expect a reduction in performance, referred to as the cost of concurrence (Wickens, 1984). This effect will be further amplified if today’s display design practice is continued.

Many companies have taken a technological approach to solve these problems in recent years, such as introducing large screen displays and increasing the number of VDUs. However, this approach often fails due to poor quality of the information presented.

Many human-centered design approaches concentrate on how to identify the information content while being either vague or conventional when it comes to how to actually present this information. While not specifying a method for identifying the information to be visualized, the focus of IRD is on weighing and classifying the relevance of types of information as well as visualizing this information in a manner that reflects its relevance. Through deemphasizing less relevant display items it becomes possible to create displays with high information density that at the same time are easily readable.

Our design uses individual shapes or “building blocks” that are the foundations used to represent basic process units. These building blocks are designed not only to work optimally as individual display elements, but also with careful consideration of how they combine into larger objects and structures and how these influence the visual search and scan patterns of a user. Tufte (1983) describes this as micro-macro representation of data. Macro representation takes into account the operators’ powerful pattern recognition skills and supports these.

It is well known that instead of reading exact process parameters, experienced operators often prefer to monitor the development of parameters over time using trend plots. Based on this, an important design goal was to integrate trends in the basic building blocks and thereby allow operators to use pattern recognition in observing process behavior.

Careful design of symbols and use of color and contrast can create the effect of having several visual layers in the graphics. For instance, visually salient layers should contain important information to be scanned easily. Designs that utilize layering to support effective reading and interpretation need to be

based on knowledge of the relative importance of different types of data and ways in which data types are related.

In earlier work on large screen overview display designs we have developed the Dull Screen principle for using color to reduce visual clutter in displays to a minimum (Haukenes et. al., 2001). In this concept, bright and saturated colors like red and yellow are reserved for signals requiring urgent actions like warnings and alarms, while static elements with little meaningful information content are presented in a faded grey tone, to avoid interference with the more important information. This principle was inspired by the mature graphical design principles found in e.g. cartography, and this idea has recently been supported by empirical research on color use and visual search strategies in process control displays (Van Laar, 2001 and 2002). The Dull Screen concept reduces the undesired visual complexity, and in IRD we further utilize the opportunity this creates for actually increasing the amount of useful information in each display.

Figure 8 provides a simple example of an indicator display designed according to IRD principles. These principles include:

- Integrating trend plots while still presenting the exact value to support a variety of tasks,
- Aligning information to support pattern recognition,
- Utilizing space and normalizing the operating range for easy comparison,
- Supporting micro/macro reading, and
- Presenting color and contrast in accordance with good design principles.

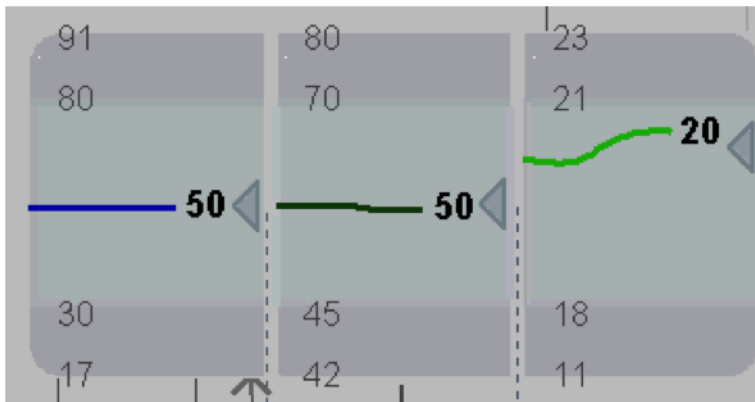

Figure 8. Example Information Rich Design Display.



## **4. HALDEN APPLICATION FOR LWRS**

### **4.1 Work Performed**

INL has contracted HRP to help develop digital control room interface prototypes in support of the LWRS program. The contract defines four tasks:

- Task 1: Install copies of the HSIs for HRP's BWR and PWR simulator in the HSSL,
- Task 2: Background and familiarization with the simulator at HSSL,
- Task 3: Connect HRP software to the LWRS simulator and establish the required software infrastructure, and
- Task 4: Design and implementation of HSI prototypes.

The main purpose of Tasks 1 through 3 is to implement a data connection between the DOE's Generic Pressurized Water Reactor (GPWR) simulator at INL (Boring et al., 2013) and HRP's software systems and prototypes from HAMMLAB in order to enable DOE to take advantage of HRP's software and tools when building HSI prototypes for the LWRS project.

As described in Section 4.2, DOE's GPWR simulator is produced by the same vendor as HRP's RIPS, and the vendor confirmed that HRP's software interface to the RIPS could be re-used as is with INL's GPWR simulator, provided GSE introduced a few minor modifications to the simulator software.

### **4.2 Background and Familiarization with DOE's GPWR Simulator**

After LWRS Project Team concluded that the project should focus on the GPWR simulator, HRP established contact with the simulator vendor, GSE Systems, to discuss the simulator's options for enabling external software to access simulator variables and issue operator actions. As GSE is also the simulator vendor for HRP's RIPS, it was obviously an attractive option to re-use directly the software used for RIPS. This software has been used in HAMMLAB for more than four years and is very well tested. GSE confirmed that only minor modifications to their simulator software were required in order to support HRP's software, and these modifications were implemented by GSE prior to a joint meeting in January, 2013, at INL.

Motivated by an ongoing project with utility partner with a control room similar to the GPWR, INL wanted HRP and GSE to investigate the feasibility of presenting and operating the HSI prototypes to be developed in Task 4 within the GPWR-simulator's soft panels available in the HSSL. During Fall, 2012, GSE designed and implemented a new feature, denoted picture-in-picture, in their simulator software platform. HRP reviewed and gave input suggestions to the design, and provided a test case to GSE to ensure a smooth integration at a January, 2013, workshop at INL. GSE confirmed in October their ability to successfully run the test case.

### **4.3 Installation and Integration Testing at INL**

During an INL-hosted meeting between INL, HRP, and GSE staff held January 15-17, 2013, HRP and GSE installed the software and performed integration testing in the LWRS HSSL. The testing was based



on a test case prepared by HRP and included visualization of measurement points and component statuses from the simulator as well as handling operator actions to manipulate valves and pumps from the display. The prototype integration of the software modules was successful, and the testing demonstrated the following capabilities:

- HRP's software was able to access variables for reading and writing in the GPWR simulator. The variable values were distributed to a number of computers for presentation in operator displays, and operators were able to control the simulation by operating the simulated process through the displays.
- GSE's picture-in-picture feature enabled presentation and operation of ProcSee-based HSI prototypes within the GPWR-simulator's panels. The development of such prototypes is the major ongoing activity for the remainder of this project.

#### 4.4 Installation of Prototype Full-Scope HSIs

In addition to installing new HSIs specific for the GPWR, HRP installed copies of the prototype HSIs for the HAMBO and RIPS simulators in the HSSL. Due to licensing restrictions, the simulator servers could not be installed at the HSSL, and only the client software was installed at the HSSL. A live data connection was implemented using a secure client connection between the client simulator GUI at the HSSL and HRP's simulator servers in Norway. Cyber security issues and other administrative issues for establishing a permanent data connection between dedicated computers at the HSSL and HRP have been resolved, and the technical issues have been implemented in accordance with these. The data connection is by default turned off at both ends, but can be opened for a specified period of time when agreed upon by INL and HRP. Requests to open the line shall be initiated by INL.

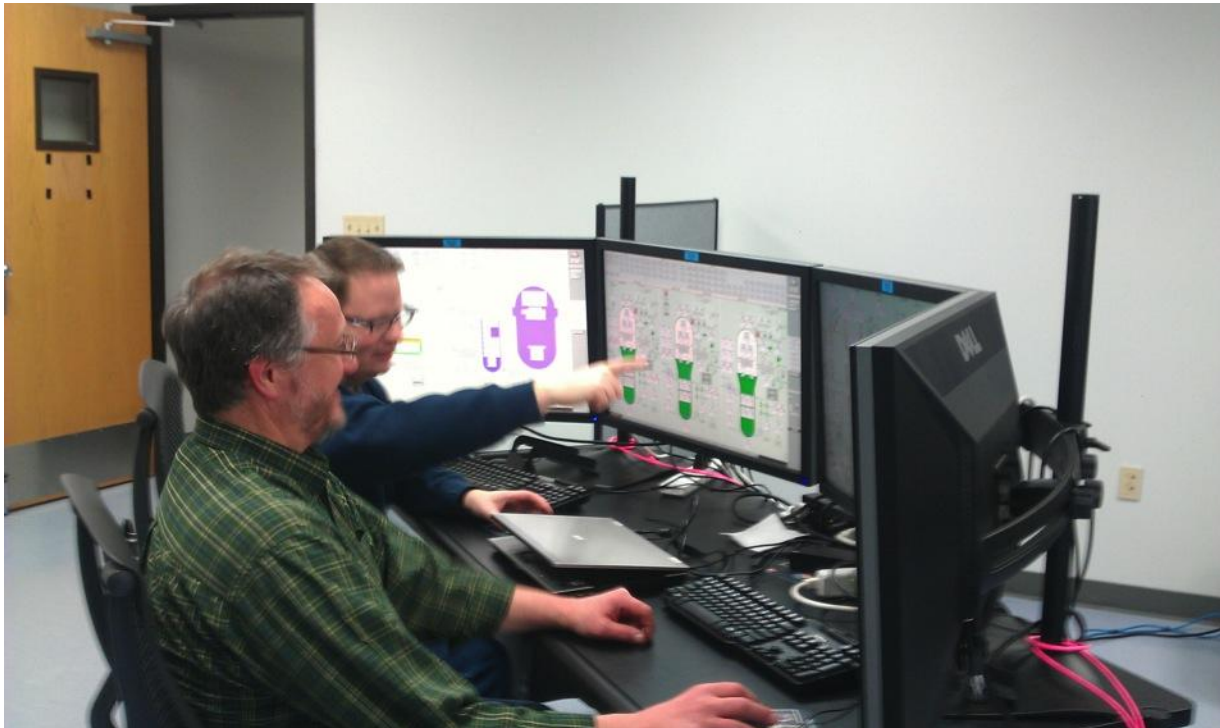

Figure 9. Remote Connection from the HSSL to the RIPS Server in Halden, Norway.



During January 15-17, 2013, the latest versions of the HSI's for HAMBO and RIPS were installed in the HSSL, and testing was carried out to ensure that both simulators can be successfully operated from the HSSL over the data connection line to Halden, Norway. At the end of the installation HRP provided a detailed, step-by-step procedure for start-up and shut-down of the HSI's to relevant INL personnel.

## 4.5 Results

The following results were achieved by the work reported here:

- A permanent solution for a data connection line between DOE's HSSL and HRP's HAMMLAB has been established. This line enables the LWRS program to study live versions of HAMMLAB's innovative HSI solutions in the HSSL for demonstrations to customers and to inspire new ideas in the LWRS program. Remote operation of the HAMMLAB simulators through the HSI's in HSSL over the data connection line has been successfully demonstrated.
- The integration of HRP's simulator software with the GPWR simulator has been successfully demonstrated. The test case included the prototype presentation of simulator values and operation of simulated process components from the HSSL glass top displays.
- The applicability of GSE's picture-in-picture feature to present and operate ProcSee-based HSI prototypes within the GPWR-simulator panels has been successfully demonstrated.

Using the now established software infrastructure, the LWRS program and HRP will be able to demonstrate relevant control room replacement systems. The first three phases of the contract demonstrate the viability of this approach and prove that the integration of HRP's technology with the LWRS simulator operates as expected. The technological infrastructure for phase four, focusing on designing and implementing HSI prototypes for relevant control room replacement systems, is now established.



## 5. CONCLUSIONS

The HRP and the LWRS Program have, together with simulator vendor GSE Systems, established the technical infrastructure for the design and implementation of additional HSI prototypes to demonstrate relevant control room replacement systems.

Additionally, IFE and the LWRS Program now have established the technical and administrative means to enable remote operation of HAMMLAB simulators from HSIs installed in the HSSL. This new feature enables INL to use live versions of HAMMLAB's innovative HSI prototypes in demonstrations to utility partners and to inspire new ideas in the LWRS program.

Current and future efforts are focused on designing and implementing additional new HSI prototypes to improve operators' situation awareness in hybrid control rooms. The prototypes will be demonstrated live in the HSSL using the GPWR. A full-scope prototype is being developed of a large screen overview display. The design is based on HRP's most recent large screen overview display for their Ringhals Unit 3 simulator, designed by experienced shift supervisors from Ringhals Unit 3 now working in Halden. The large screen overview display for the Ringhals Unit 3 simulator is now implemented in HAMMLAB and will be used in two Halden experiments later this year.

For the LWRS Program, the design and implementation is being modified to reflect actual GPWR processes rather than the Ringhals Unit 3 processes. It is jointly presented on three screens in the glass top simulator in the HSSL (see Figure 10). The display is connected to live data from GPWR simulator at the HSSL.

The Electric Power Research Institute (EPRI; 2004) cites a significant challenge in incorporating human factors engineering and meeting human performance goals with hybrid and full digital control rooms. They note, "As part of modernization, HSIs are becoming more computer-based, incorporating features such as soft controls, computer-based procedures, touch-screen interfaces, sit-down workstations, and large-screen overview displays." HRP has a long history developing and validating advanced control room concepts in support of the oil and nuclear industries. The purpose of this collaborative research project with the DOE is to enable the U.S. nuclear industry to access these design innovations. This report chronicles many of those innovations and the first steps toward design prototypes in support of control room modernization in the U.S. Working together the LWRS Program and HRP will continue to develop prototypes that may be deployed in a U.S. NPP setting, enabling industry to apply best design practices and state-of-the-art HSIs to its control room upgrades.

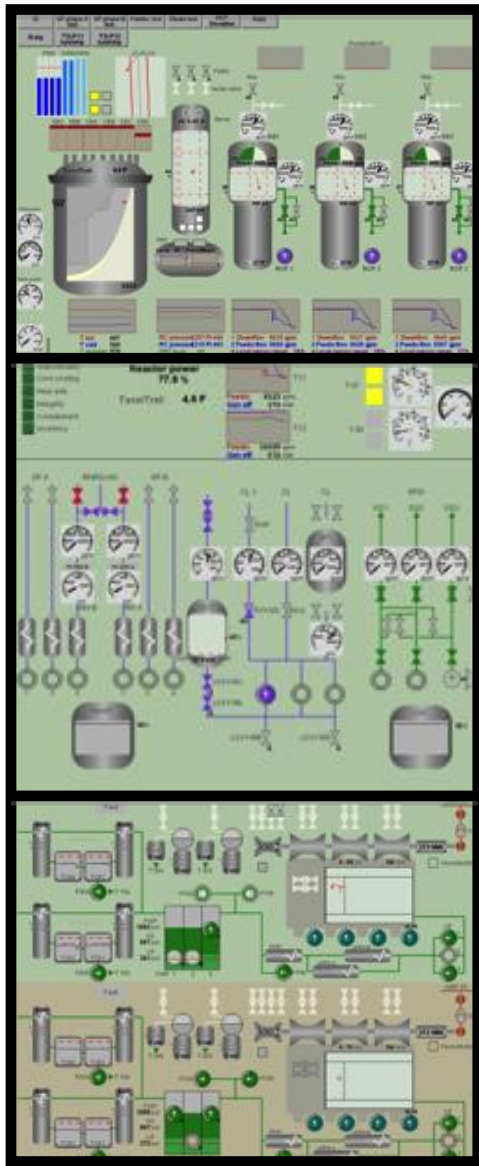
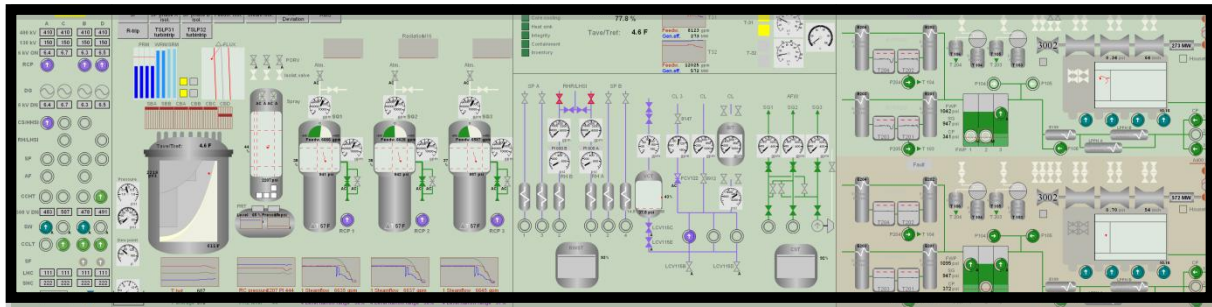

Figure 10. Large Screen Display for RIPS (top) Adapted for LWRs Glasstop (bottom).

## 6. REFERENCES

- Aaser, W., Andersson, T., Berg, Ø., Førdestrømmen, N.T., Hval, S., & Jørgensen, U.S. (1985). Installation of the Core Surveillance System SCORPIO at the Ringhals Nuclear Power Plant, HWR-147. Halden, Norway: OECD Halden Reactor Project.
- Andresen G., and Pirus D. (2005). Development and Evaluation of a Function-oriented Display System: Background and Initial Results, The 2005 ISOFIC Conference, Korea.
- Andresen, G., & Drøivoldsmo, A. (2000). Human Performance Assessment: Methods and Measures, HPR-353. Halden, Norway: OECD Halden Reactor Project.
- Andresen, G., Friberg, M., Teigen, A., & Pirus, D. (2004). Function-Oriented Display System: Background and First Prototypes, HWR-752. Halden, Norway: OECD Halden Reactor Project.
- Andresen, G., Friberg, M., Teigen, A., & Pirus, D. (2005a). Function-Oriented Display System: First Usability Test, HWR-789. Halden, Norway: OECD Halden Reactor Project.
- Andresen, G., Teigen, A., Broberg, H., & Friberg, M. (2005b). Function-Oriented Display System: Lessons Learned From the Development Process, HWR-793. Halden, Norway: OECD Halden Reactor Project.
- Baker, S., Gertman, D., Hollnagel, E., Holmström, C., Marshall, E., & Øwre, F. (1985). An Experimental Comparison of Three Computer-Based Alarm Systems: Results and Conclusions, HWR-142. Halden, Norway: OECD Halden Reactor Project.
- Barmsnes, K.A., Hornæs, A., Jakobsen, Ø., & Storkås, R. (1991a). Picasso-3 Functional Specification, HWR-278. Halden, Norway: OECD Halden Reactor Project.
- Barmsnes, K.A., Hornæs, A., Jakobsen, Ø., & Storkås, R. (1991b). Picasso-3 System Design, HWR-288. Halden, Norway: OECD Halden Reactor Project.
- Berglund, L., Fantoni, P., Kaarstad, M., Lindström, M., Meyer, G., Olsén, J. & Sørensen, A. (1995). The Use of CAMS during a Safety Exercise at the Swedish Nuclear Inspectorate, HWR-423. Halden, Norway: OECD Halden Reactor Project.
- Boring, R.L. (2011). Alarm Design Workshop for Control Room Upgrades, INL/MIS-11-22907. Idaho Falls: Idaho National Laboratory.
- Boring, R., Agarwal, V., Fitzgerald, K., Hugo, J., & Hallbert, B. (2013). Digital Full-Scope Simulation of a Conventional Nuclear Power Plant Control Room, Phase 2: Installation of a Reconfigurable Simulator to Support Nuclear Plant Sustainability, INL/EXT-13-28432. Idaho Falls: Idaho National Laboratory.
- Boring, R.L., Agarwal, V., Joe, J.C., & Persensky, J.J. (2012). Digital Full-Scope Mockup of a Conventional Nuclear Power Plant Control Room, Phase 1: Installation of a Utility Simulator at the Idaho National Laboratory, INL/EXT-12-26367. Idaho Falls: Idaho National Laboratory.
- Braarud, P. Ø. (1998). Complexity Factors and Prediction of Crew Performance, HWR-521. Halden, Norway: OECD Halden Reactor Project.
- Braarud, P. Ø. (2000). Subjective Task Complexity in the Control Room, HWR-621. Halden, Norway: OECD Halden Reactor Project.
- Braarud, P.Ø., & Skraaning, G. (2006). Insights from a benchmark integrated system validation of a modernized NPP control room : performance measurements and the comparison to the benchmark system, American Nuclear Society International Topical Meeting on Nuclear Plant Instrumentation, Controls, and Human Machine Interface Technology, 5, Albuquerque, NM, 12-16 November, 2006.

- Braarud, P.Ø., & Skraaning, G. (2007). Insights from Benchmark Integrated System Validation of a Modernized NPP Control Room: Performance Measurement and the Comparison to the Benchmark System, Paper C1.10, HPR-367, Vol. 1. Halden, Norway: OECD Halden Reactor Project.
- Burns, C., Skraaning, G., Jamieson, G.A., Lau, N., Welch, R., & Andresen, G. (2008). Evaluation of Ecological Interface Design for Nuclear Process Control: Situation Awareness Effects, Human Factors, 50(4), 663-679.
- Collier, S. (2005). HRA – Lessons Learnt from Previous Experiments, HWR-811. Halden, Norway: OECD Halden Reactor Project.
- Collier, S., & Andresen, G. (2000). A Second Study of the Prediction of Cognitive Errors Using the “CREAM” Technique, HWR-625. Halden, Norway: OECD Halden Reactor Project.
- Easter, J. (1991). Role of the Operator and Control Room Design. In J. White, D. Lanning, L. Beltracchi, F. Best, J. Easter, L. Oakes, and A Sudduth (Eds.). WTEC Panel on European Nuclear Instrumentation and Controls (Report No. PB92-100197). Washington, DC: National Technical Information Service.
- Electrical Power Research Institute. (2004). Human Factors Guidance for Control Room and Digital Human-System Interface Design and Modification. Guidelines for Planning, Specification, Design, Licensing, Implementation Training, Operation, and Maintenance, EPRI-TR-1008122. Palo Alto, CA: Electrical Power Research Institute.
- Fält, C-O., Grini, R-E., Raussi, P., Saarni, R., Stokke, E., & Sørenssen, A. (1998a). Requirements to Simulators for HAMMLAB 2000, HWR-496. Halden, Norway: OECD Halden Reactor Project.
- Fält, C-O., Grini, R-E., Raussi, P., Saarni, R., Stokke, E., & Sørenssen, A. (1998b). Requirements to Simulator Building Tools for HAMMLAB 2000, HWR-497. Halden, Norway: OECD Halden Reactor Project.
- Fantoni, P. Iguchi, Y., Meyer, F., Sørenssen, A., & Van Dyck, C. (1996). CAMS Prototype Extension: Integration of Data Acquisition, Signal Validation, Tracking Simulator, Predictive Simulator, State Identification, and Probabilistic Safety Assessment, HWR-440. Halden, Norway: OECD Halden Reactor Project.
- Fantoni, P., Meyer, G., Nurmilaukas, P., Sirola, M., & Sørenssen, A. (1994). Description of the Computerized Accident Management Support System (CAMS) Prototype and Design, HWR-390. Halden, Norway: OECD Halden Reactor Project.
- Fantoni, P.F., Fagedy, S., & Racz, A. (1998). PEANO, A Toolbox for Real-Time Process Signal Validation and Estimation, HWR-515. Halden, Norway: OECD Halden Reactor Project.
- Fantoni, P.F., Hoffmann, M., Lipcsei, S. & Roverso, D. (1999). PEANO: Advancements in 1998-1999, HWR--585. Halden, Norway: OECD Halden Reactor Project.
- Follesø, K., & Volden, F.S. (1992). A Guideline Evaluation of the Man-Machine Interface of the ISACS-1 Prototype, HWR-309. Halden, Norway: OECD Halden Reactor Project.
- Follesø, K., & Volden, F.S. (1993a). The ISACS-1 Evaluation: A Simulator Based User Test of the ISACS-1 Prototype, HWR-342. Halden, Norway: OECD Halden Reactor Project.
- Follesø, K., & Volden, F.S. (1993b). Lessons-Learned on Test and Evaluation Methods from Test and Evaluation Activities Performed at the OECD Halden Reactor Project”, HWR-336. Halden, Norway: OECD Halden Reactor Project.
- Follesø, K., Kaarstad, M., Drøivoldsmo, A, Hollnagel, E., & Kirwan, B. (1996). Practical Insights from Initial Studies Related to Human Error Analysis Project (HEAP), HWR-459. Halden, Norway: OECD Halden Reactor Project.

- Førdestrømmen, N. (2004). Task-Based Displays – Rationale, Design, User Test and Assessment, HWR-751. Halden, Norway: OECD Halden Reactor Project.
- Førdestrømmen, N.T., Jørgensen, U.S., Kårstad, T., Meyer, B., & Nelson, W.R. (1991). ISACS-1: Man-Machine Interface and User Perspectives, HWR-297. Halden, Norway: OECD Halden Reactor Project.
- Gunnarsson, T., & Farbrot, J.E. (2004). The Control Room Upgrade in the Oskarshamn 1 Modernisation Project, Paper C2.1, HPR-363, Vol. 1. Halden, Norway: OECD Halden Reactor Project.
- Haugset, K., Berg, Ø., Bologna, S., Evjen, O., Nelson, W.R., & Yamane, N. (1990) ISACS-1. Motivation, General Description, HWR-265. Halden, Norway: OECD Halden Reactor Project.
- Haukenes, H., Veland, Ø., Seim, L.Å., & Førdestrømmen, N.T. (2001). Petro-HAMMLAB Overview Displays: Design – Design Rationale, Experiences, Paper C2.16, HPR-357. Halden, Norway: OECD Halden Reactor Project.
- Hogg, D.N., Follesø, K., Torralba, B., & Volden, F.S. (1994). Measurement of the Operator's Situation Awareness for Use within Process Control Research: Four Methodological Studies, HWR-377. Halden, Norway: OECD Halden Reactor Project.
- Hollnagel, E., Hunt, G., & Marshall, E. (1984). The Experimental Validation of the Critical Function Monitoring System. Executive Summary, HPR-312. Halden, Norway: OECD Halden Reactor Project.
- Hornæs, A., Hveding, T., Pettersen, G., & Storkås, R. (1988). Picasso-2 – A Highly Automated Man-Machine Communication Design Tool for Real Time Applications, HWR-226. Halden, Norway: OECD Halden Reactor Project.
- Hornæs, A., Pettersen, F. Pettersen, G., & Storkås, R. (1990). Picasso – An Advanced Graphic User Interface Management System for Real-Time Applications, HWR-271. Halden, Norway: OECD Halden Reactor Project.
- Joe, J.C., Boring, R.L., and Persensky, J.J. (2012). Commercial utility perspectives on nuclear power plant control room modernization. 8th International Topical Meeting on Nuclear Power Plant Instrumentation, Control, and Human-Machine Interface Technologies (NPIC&HMIT), 2039-2046.
- Jokstad, H., Karlsen, T., Mohn, P., Ness, E., & Sundling, C-V. (1988). HAMMLAB 2000 Integration Platform Pre-Study, HWR-498. Halden, Norway: OECD Halden Reactor Project.
- Kaarstad, M, Hollnagel, E., & Lee, H-C. (1998). Human Error Analysis Project (HEAP) – Report from Main Experiment 1, HWR-540. Halden, Norway: OECD Halden Reactor Project.
- Kaarstad, M. (1995). Development of a Task Descriptive Model of the Operator's Fault Diagnosis: A Framework for Interpreting Empirical Data within the Human Error Project, HWR-379. Halden, Norway: OECD Halden Reactor Project.
- Karlsson, T., Jokstad, H., Meyer, B.D., Nihlwing, C., Norrman, S., Puska, E.K., Raussi, P., & Tiihonen, O. (2001). The HAMBO BWR Simulator of HAMMLAB, HWR-663. Halden, Norway: OECD Halden Reactor Project.
- Karlsson, T., Meyer, B.D., Jokstad, H., Farbrot, J.E., & Hulsund, J.E. (2002). The Alarm System for the HAMBO BWR Simulator, HWR-702. Halden, Norway: OECD Halden Reactor Project.
- Kemeny, J.G. (1979). President's Commission: The Need for Change: The Legacy of TMI. Washington, DC: U.S. Government Printing Office.
- Kvalem, J., Berg, Ø., Førdestrømmen, N.T., Groven, A-K., Hollnagel, E., Pettersen, F., Solie, Å. S., Stokke, E., & Sundling, C-V. (1996). HAMMLAB 2000 – Long-Term Perspectives for Use of HAMMLAB, HWR-452. Halden, Norway: OECD Halden Reactor Project.

- Lau, N., Skraaning, G., Jamieson, G.A., & Burns, C. (2008). The Impact of Ecological Displays on Operator Task Performance and Workload, HWR-888. Halden, Norway: OECD Halden Reactor Project.
- Lirvall, P. (1998). Control Room Design and Human Factors Using a Virtual Reality Based Tool for Design, Testing & Training, HWR-519. Halden, Norway: OECD Halden Reactor Project.
- Lois, E. Parry, G., Persensky, J., Bye, A, Broberg, H, & Dang, V.N. (2008a). The International Empirical HRA Study Using Simulator Human Performance Data, Paper presented at ANS PSA 2008 Topical Meeting: Challenges to PSA During the Nuclear Renaissance, Knoxville, Tennessee, USA, 7-11 September, 2008
- Lois, E., Dang, V.N., Forester, J. Broberg, H., Massaiu, S., Hildebrandt, M., Braarud, P.Ø., Parry, G., Persensky, J., Boring, R., Männistö, I., & Bye, A. (2008b). International HRA Empirical Study – Pilot Phase Report. Description of Overall Approach and First Pilot Results from Comparing HRA Methods to Simulator Data, HWR-844. Halden, Norway: OECD Halden Reactor Project.
- Louka, M.N. (1999). An Introduction to Virtual Reality Technology, HWR-588. Halden, Norway: OECD Halden Reactor Project.
- Louka, M.N., & Beere, B.J. (1998). Session Summaries for Workshop Meeting on Virtual Reality Applications in Process Industry Maintenance Training, Outage Planning, Control Room Retrofits and Design, 17-18 September 1998, HWR-571. Halden, Norway: OECD Halden Reactor Project.
- Lund, P.C., Mathisen, K.W., Nedreliid, O., & Slora, B.R. (1996). MOCOM – Model-Based Condition Monitoring System for Plant Maintenance Optimisation, HWR-463. Halden, Norway: OECD Halden Reactor Project.
- Marshall, E., Hollnagel, E., & Tuominen, L. (1983). The Experimental Validation of the Critical Function Monitoring System. The Training Programme, HPR-303. Halden, Norway: OECD Halden Reactor Project.
- Massaiu, S., Skjerve, A.B.M., Skraaning, G., Strand, S., & Wærø, I. (2004). Studying Human-Automation Interactions: Methodological Lessons Learned from the Human-Centred Automation Experiments 1997-2001, HWR-760. Halden, Norway: OECD Halden Reactor Project.
- Netland, K., & Hol, J. Ø. (1977). Development of a Computer and Colour Display-Based Control Room (OPCOM) for Experimental Operation of the Halden Reactor, HPR-202. Halden, Norway: OECD Halden Reactor Project.
- Netland, K., & Lunde, J.E. (1975). Experimental Operation of the Halden Reactor Utilizing a Computer and Colour Display-Based Control Room, Specialist Meeting on Control Room Design, San Francisco, USA.
- O’Hara, J., & Brown, W. (2002). The Effects of Interface Management Tasks on Crew Performance and Safety in Complex, Computer-Based Systems, NUREG/CR-6633. Washington, DC: U.S. Nuclear Regulatory Commission.
- O’Hara, J., Stubler, W., Higgins, J., & Brown, W. (1997). Integrated System Validation: Methodology and Review Criteria, NUREG/CR-6393, Washington DC: U. S. Nuclear Regulatory Commission.
- O’Hara, J.M., Higgins, J.C., Persensky, J.J., Lewis, P.M. & Bongarra, J.P. (2004). Human Factors Engineering Programme Review Model, NUREG-0711, Rev. 2, Washington DC: US Nuclear Regulatory Commission.
- Parry, G., Lois, E., Forester, J.A., Dang, V.N., Persensky, J., & Bye, A. (2008). Insights from Comparison of HRA Method Prediction with Empirical Data on Human Performance in Accident Scenarios, Paper



presented at PSAM9, Proceedings of the 9th International Probabilistic Safety Assessment and Management Conference, May 18-23, 2008, Hong Kong, China

- Pettersen, F. (1971). Description of System Hardware for the Main Process Computer Installation at the HBWR, HPR-123. Halden, Norway: OECD Halden Reactor Project.
- Randem, H.O., Jokstad, H., Linden, T., Kvilesjø, H.Ø., Rekvinn, S., & Hornæs, A. (2005). ProcSee – The Picasso Successor, HWR-799. Halden, Norway: OECD Halden Reactor Project.
- Reiersen, C.S., Marshall, E.C., & Baker, S.M. (1987). A Comparison of Operator Performance When Using Either an Advanced Computer-Based Alarm System or a Conventional Annunciator Panel, HPR-331. Halden, Norway: OECD Halden Reactor Project.
- Roverso, D. (1998). Aladdin: A Neural Model for Event Classification in Dynamic Processes, HWR-516. Halden, Norway: OECD Halden Reactor Project.
- Roverso, D. (1999). Aladdin: Advancements and Applications to the Diagnosis of PWR Islanding Anomalies, HWR-576. Halden, Norway: OECD Halden Reactor Project.
- Skraaning, G. (1998). The Operator Performance Assessment System (OPAS), HWR-538. Halden, Norway: OECD Halden Reactor Project.
- Skraaning, G., Lau, N., Welch, R., Nihlwing, C., Andresen, G., Brevig, L.H., Veland, Ø., Jamieson, G.A., Burns, C., & Kwok, J. (2007). The Ecological Interface Design Experiment (2005), HWR-833. Halden, Norway: OECD Halden Reactor Project.
- Sørensen, A., de Carvalho, P.V.R., Karlsson, T. Meyer, B.D., Nihlwing, C., Nystad, B., & Saarni, R. (1999). The Operator Interface of the BWR Simulator in HAMMLAB, HWR-592. Halden, Norway: OECD Halden Reactor Project.
- Stokke, E. (1981). New Experimental Control Room Test Facility, HPR-282. Halden, Norway: OECD Halden Reactor Project.
- Strand, S., Svengren, H., Nihlwing, C. Kristiansen, L-I., Andresen, G., & Meyer, B.D. (2007). Task-Based Displays – Prototype Extensions and the Second User Test, HWR-841. Halden, Norway: OECD Halden Reactor Project.
- Stubler, W. F. & O'Hara, J. M. (1996). Group-view Displays: Functional Characteristics and Review Criteria, Tech. Report E2090-T-4-4-12/94. Upton, New York: Brookhaven National laboratory.
- Sunde, S., & Berg, Ø. (1998). Thermal Performance Monitoring and Optimisation, HWR-514. Halden, Norway: OECD Halden Reactor Project.
- Sunde, S., Banati, J., García, R., Carrasco, J.A., & Fernandez Illobre, L. (2002). Progress in Monitoring and Optimisation of Thermal Performance-TEMPO, HWR-688. Halden, Norway: OECD Halden Reactor Project.
- Sundling, C-V., & Arnesen, K. (1985). CAMPS – Computer System Applying Microprocessor Structures for Process Presentation and Control, HWR-146. Halden, Norway: OECD Halden Reactor Project.
- Svengren, H., & Meyer, B.D. (2005). Outage Information System, HWR-794. Halden, Norway: OECD Halden Reactor Project.
- Svengren, H., & Strand, S. (2005). Design of the Task-Based Display Prototype and the First User Test, HWR-792. Halden, Norway: OECD Halden Reactor Project.
- Tufte, E. (1983). The Visual Display of Quantitative Information. Cheshire, CT: Graphics Press.
- Van Laar, D.L. (2001). Psychological and cartographic principles for the production of visual layering effects in computer displays. *Displays*, 22, 125–135.

- Van Laar, D.L. (2002). Evaluation of a visual layering methodology for colour coding control room displays. *Applied Ergonomics* 33, 371–377.
- Welch, R., Braseth, A.O., Nihlwing, C., Skraaning, G., Teigen, A., Veland, Ø., Lau, N., Jamieson, G.J., Burns, C.M., & Kwok, J. (2007). The 2005 Ecological Interface Design Process and the Resulting Displays, HWR-847. Halden, Norway: OECD Halden Reactor Project.
- Welch, R., Friberg, M., Nystad, E., Teigen, A., and Veland, Ø. (2004). Ecological Interface Displays, HWR-790. Halden, Norway: OECD Halden Reactor Project.
- Wickens, D. (1984). *Engineering Psychology and Human Performance*, Second Edition. Upper Saddle River, NJ: Prentice Hall.
- Wioland, L., Kaarstad, M., & Skraaning, G. (2000). Error Detection and Recovery-Results from Experiment 1997, HWR-622. Halden, Norway: OECD Halden Reactor Project.
- Woods, D, Roth, E., Stubler, W., and Mumaw, R. (1990). Navigating through large display networks in dynamic control applications. *Proceedings of the Human Factors Society 34th Annual Meeting*. Santa Monica, CA: Human Factors Society.