

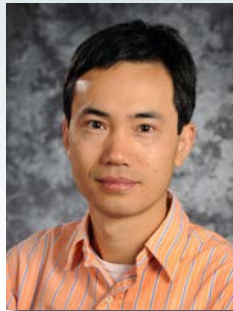

## Demonstration of RELAP-7 Capabilities Via Application to a Simplified Boiling Water Reactor Extended Station Blackout

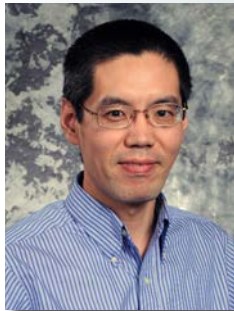

**Hongbin Zhang, Haihua Zhao, Ling Zou, Richard Martineau, and Curtis Smith**  
Risk-Informed Safety Margin Characterization Pathway

The Reactor Excursion and Leak Analysis Program-7 (RELAP-7) code is the next generation nuclear reactor system safety analysis code and is currently under development at the Idaho National Laboratory. The code will be the main reactor systems simulation tool for the Risk-Informed Safety Margin Characterization Pathway of the Light Water Reactor Sustainability (LWRS) Program and the next generation tool in the RELAP reactor systems safety analysis application series. RELAP-7 code development is taking advantage of the progress made in the past several decades to achieve simultaneous advancement of physical models, numerical methods, and software design. RELAP-7 uses Idaho National Laboratory's Multi-Physics Object-Oriented Simulation Environment (MOOSE) framework (Gaston et al. 2009) for efficiently and effectively solving computational engineering problems. Unlike traditional system codes, all of the physics in RELAP-7 can be solved simultaneously (i.e., *fully coupled*), resolving important dependencies and significantly reducing spatial and temporal errors relative to traditional approaches. This allows RELAP-7 development to focus strictly on systems analysis-type physical modeling and gives priority to the retention and extension of RELAP5's system safety analysis capabilities.

A reactor system is complex and contains hundreds of different safety-related components. Therefore, it is

impractical to resolve the actual geometry of the whole system. Instead, simplified thermal hydraulic models are used to represent the major physical components and describe major physical processes (e.g., fluids flow and heat transfer). There are three main types of components in RELAP-7: (1) one-dimensional (1-D) components, (2) zero-dimensional (0-D) components for setting boundary conditions for the 1-D components, and (3) 0-D components for connecting 1-D components. An example of a 1-D component would be a pipe, while an example of a 0-D component would be a pump. The modular approach to MOOSE-based models enables detailed resolution where needed; for example, RELAP-7 could be coupled to a three-dimensional core model if detailed core analysis is needed.

The RELAP-7 code development project started in 2012. During the first year of code development, the software framework was created to establish the basic reactor system simulation capability with a number of components developed for single-phase thermal fluid flow (INL 2012). During the second year of development in 2013, basic two-phase flow modeling capability was implemented. These capabilities are demonstrated via

*Continued on next page*



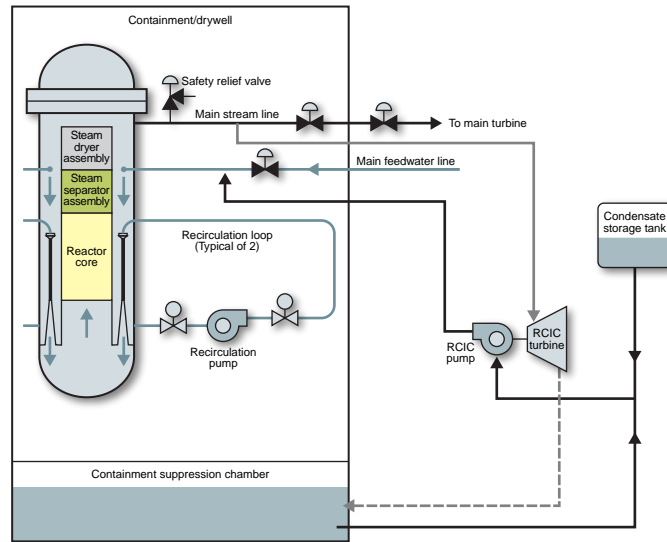

Figure 1. Reactor core isolation cooling system (reproduced from INPO [2011]).

Continued from previous page

application to a boiling water reactor (BWR) simulation, with simplified geometries under extended station blackout (SBO) transient conditions (INL 2013a).

**Background Information for Station Blackout**

The Fukushima Daiichi accident events demonstrated the need for a nuclear power plant to keep its safety systems functioning even if normal power sources and emergency diesel generators are lost under extended SBO conditions. Hence, safety improvements for nuclear power plants are required to keep the core cooled and to maintain the containment integrity such that nuclear power plants can safely withstand an extended SBO and the resulting loss of heat removal systems. Extended SBOs are beyond-

design-basis events that involve complex multi-physics phenomena and highly dynamic processes. High-fidelity and well-integrated simulation tools would enable a better understanding of the accident progression and resulting effects on the plant system to guide potential plant safety improvements. One objective of the Risk-Informed Safety Margin Characterization Pathway and RELAP-7 project is to provide this type of tool.

In 2013, the development effort focused on demonstrating simplified BWR SBO analyses with the reactor core isolation cooling (RCIC) system dynamically simulated and fully coupled with the primary system and containment of the plant. The RCIC system (shown schematically in Figure 1) provides makeup water to the reactor vessel for core cooling when the main steam lines are isolated and the normal supply

Figure 2. Schematics of a simplified boiling water reactor plant system.

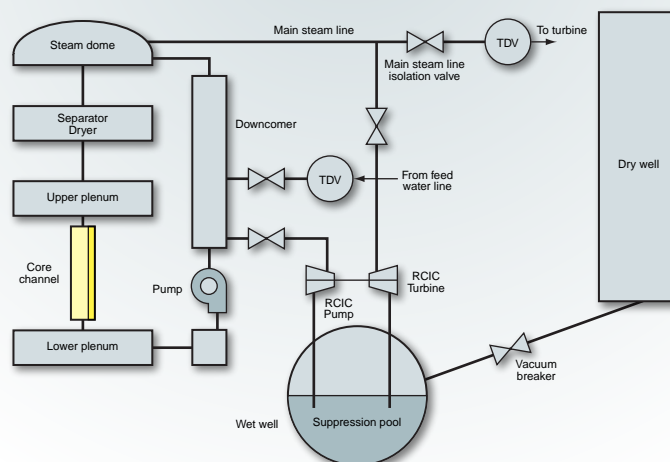

Component name	Descriptions	Dimension
Pipe	1-D fluid flow within 1-D solid structure with wall friction and heat transfer	1-D
Core Channel	Simulating reactor flow channel and fuel rod, including 1-D flow and 1-D or two-dimensional fuel rod heat conduction	1-D
Time-Dependent Volume	Provides pressure, temperature, and void fraction boundary conditions for 1-D components	0-D
Volume Branch	Multiple inlets and outlets 0-D junction, with user-provided form loss coefficients	0-D
Pump	A junction model with a momentum source connecting two 1-D components	0-D
Ideal Pump	A junction model with a given mass flow rate to simulate ideal pump behavior	0-D
Separator Dryer	Separate steam and water with mechanical methods	0-D
Downcomer	Large volume to mix different streams of water and steam and to track the water level	0-D
Valve	Simulate control mechanisms of real valves in a hydrodynamic system	0-D
Turbine	A simplified dynamical turbine model to simulate an RCIC turbine, which drives the RCIC pump through a common shaft	0-D
Wet Well	Simulate a BWR suppression pool and its gas space	0-D
Reactor	A virtual component that allows users to input the reactor power	0-D

**Table 1. Major components developed to perform boiling water reactor station blackout analysis.**

of water to the reactor vessel is lost (U.S. Nuclear Regulatory Commission 2003). The RCIC system consists of a turbine and the turbine-driven pump, piping, and valves necessary to deliver water to the reactor vessel during accident conditions. The turbine is driven by steam that is supplied from the main steam lines and it is designed to quickly accelerate from standby to a full load condition. The turbine exhaust is routed to the suppression pool inside the wet well. The RCIC system operates independently of AC power, service air, or external cooling water systems. The only required external energy source is from the battery to control the system. RCIC was one of the few safety systems still available during the Fukushima Daiichi accidents after the tsunami hit the plants; the system delayed the core meltdown for a few days in Units 2 and 3 (INPO 2011). Therefore, detailed models for RCIC system components are necessary to more accurately understand the transient behaviors under extended SBO conditions for BWRs.

### **RELAP-7 Simulation of Simplified Boiling Water Reactor Station Blackout**

A simplified BWR plant system model was built based on the parameters specified in the Organization for Economic Cooperation and Development turbine trip benchmark problem (NEA/NSC/DOC 2001). Figure 2 shows the schematics of the simplified BWR plant system that was analyzed with RELAP-7.

RELAP-7 analysis entails the assembly of RELAP-7 components. As part of the RELAP-7 development effort, the components shown in Table 1 were developed for BWRs and are used to simulate the SBO transients. More than 40 RELAP-7 components were used to model the SBO transients that are made up of twelve types of components. These twelve components include reactor, volume branch, core

channel, pipe, separator dryer, valve, time-dependent volume, turbine, ideal pump, wet well, downcomer, and pump. For this algorithmic proof of concept demonstration, the BWR geometry and two-phase flow model are simplified. For 2014, realistic BWR geometry and full implementation of the 7-equation two-phase flow model (INL 2013) will be used to fully demonstrate the RELAP-7 algorithmic concept.

A reactor component is used to provide the reactor power level. A volume branch component is used to simulate a junction with volume and is used to simulate the lower plenum, the upper plenum, and the steam dome. A core channel component model (i.e., flow channel with heat structure attached to it) was used to describe the reactor core. Each core channel component represents thousands of real cooling channels and fuel rods. To speed up the transient simulation, only one core channel component was used to represent the entire core; bypass flow was ignored. The pipe component is the most basic 1-D component model in RELAP-7 and is used to simulate fluid flow in a pipe. The separator dryer component is used to simulate the steam separator assembly and the steam dryer assembly. The valve component simulates plant control mechanisms. The time-dependent volume component is used to set boundary conditions. The turbine component is used to simulate RCIC turbine behavior. The ideal pump component is used to simulate RCIC pump flow. The wet well component simulates the suppression pool and the gas space above it. The downcomer component simulates thermal fluids flow between the core shroud and the vessel. The pump component is used to simulate jet pumps and recirculation loops. Additional details of the plant model as implemented in RELAP-7 are found in INL (2013a).

*Continued on next page*

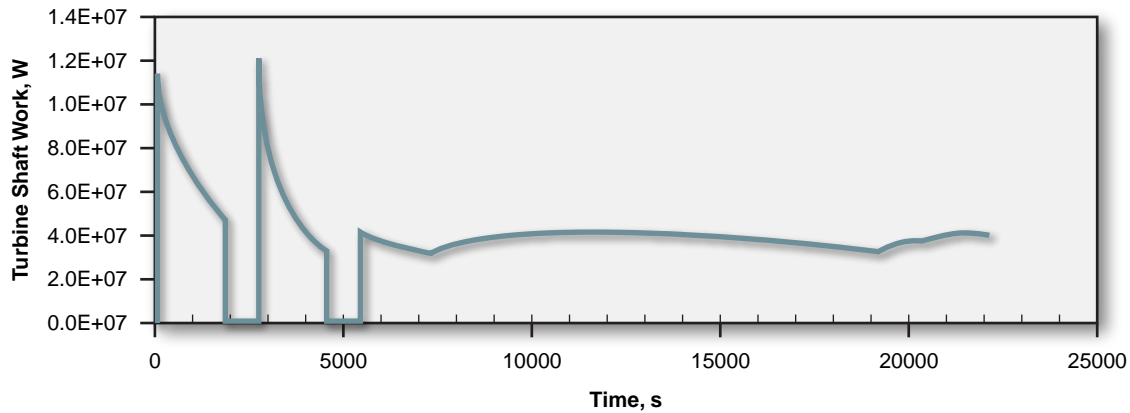

Figure 3. Reactor core isolation cooling turbine shaft work during a station blackout transient.

*Continued from previous page*

The simulation was first run to steady state with the rated thermal power, then the simulation was continued to perform the transient SBO simulation. Reactor scram is assumed to occur when offsite power is initially lost. Therefore, the heating source comes from the decay heat of the fuel in the reactor core. In the SBO transient simulation, the RCIC system is turned on and off for three periods until the assumed battery energy is exhausted. Then the turbine is kept on to simulate pressure release through the safety relief valve (note: the safety relief valve model will be available in the near future); the makeup water through the RCIC pump is shutdown. The reactor water level gradually decreases due to loss of the reactor vessel water inventory to the suppression pool. Dry out happens after the downcomer water level becomes very low. The peak fuel clad temperature rapidly increases after dry out. The simulation was set to stop when the peak clad temperature reached 1200 K (i.e., before core damage).

Figures 3 through 5 show select simulation results, allowing examination of trends to indicate the model is performing correctly. Figure 3 shows RCIC turbine shaft work during SBO. The first two RCIC on/off periods are clearly identifiable in Figure 3. The shaft work (or turbine power) is determined dynamically by plant operational conditions. The turbine's dynamic behavior is well captured by the new turbine model. This is a major improvement over traditional SBO simulations, where a given mass flow rate is typically used to simulate turbine behavior. During extended SBO events (as demonstrated in the Fukushima Daiichi accident events), major instruments are typically not available. The traditional approach of using estimated turbine mass flow rate and power would yield simulation results with large uncertainties. The dynamic models presented here would calculate the turbine mass flow rate and power based on plant transient conditions to produce simulation results with quantifiable uncertainties. Figure 4 shows the reactor core peak clad temperature. The peak clad temperature decreases when the RCIC system is on and increases during

Figure 4. Peak clad temperature during a station blackout transient.

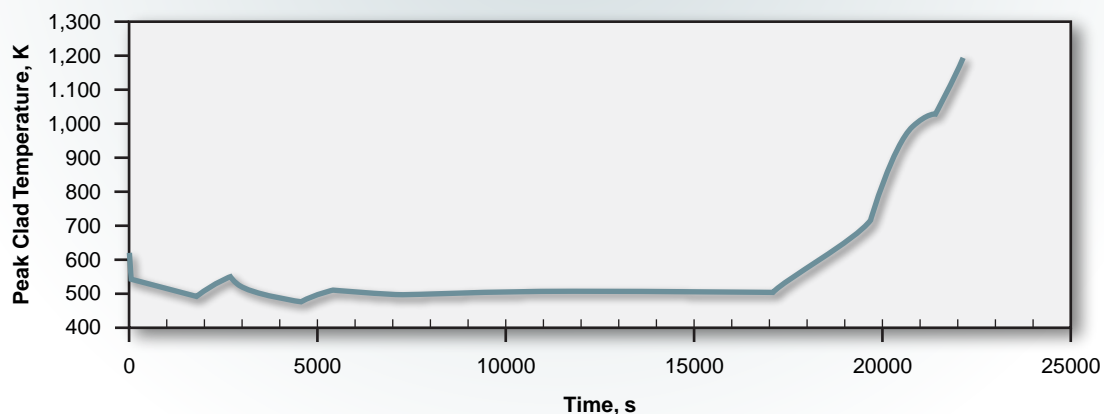

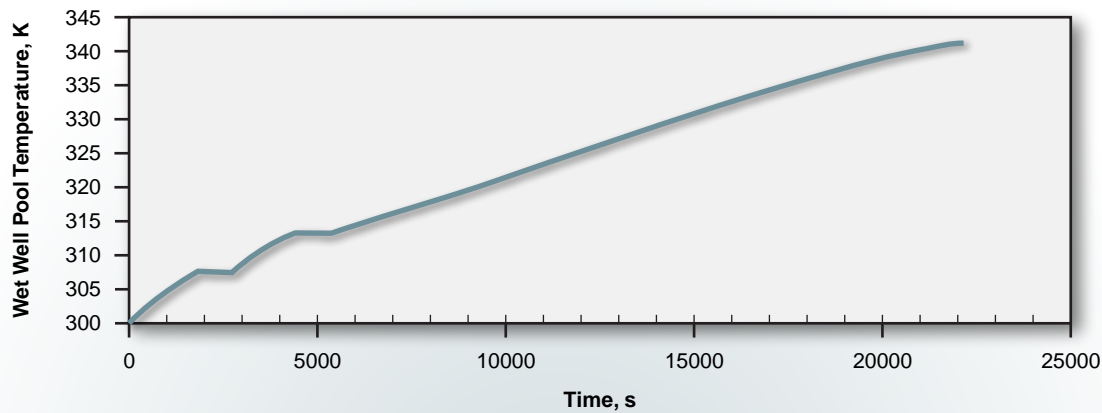

Figure 5. Wet well pool water temperature during a station blackout transient.

the time it is off. When the RCIC system's makeup water injection stops, the peak clad temperature changes slowly with system pressure until dry out occurs. Then the peak clad temperature increases very quickly. Figure 5 shows the suppression pool's water temperature variation during SBO. This is an important parameter for determining the available net positive suction head and the availability and performance of the RCIC pump. The water temperature rose by 41 K from the steady-state value of 300 K. The conservative value for the pool temperature limit (i.e., 373 K) is the boiling temperature at atmospheric pressure.

### Conclusions

This proof-of-concept analysis demonstrates the ability of RELAP-7, after 2 years of development effort, to perform BWR transient simulations under SBO conditions. Although the simulation was based on simplified geometries and two-phase flow models, the fully coupled RCIC system's simulation capability represents a first-of-a-kind capability and will provide more accurate SBO simulations upon further RELAP-7 developmental maturation. The fully coupled simulation capabilities demonstrated with RELAP-7 have significant implications in terms of providing the Risk-Informed Safety Margin Characterization Pathway with a high-fidelity deterministic tool for studying the effects of important safety parameters such as the battery lifetime, net positive suction head of the RCIC pump, and the impact of offsite power recovery time. The RELAP-7 code could be developed further to study certain important issues that are now confronting the nuclear industry (such as hardened venting and filtered venting requirements for BWRs with Mark I and Mark II containments).

For safety margin characterization analysis, mechanistic codes such as RELAP-7 are coupled to probabilistic codes (RAVEN) (INL 2013b) to run multiple RELAP-7 simulations by changing specific portions of the input files, representing changes to actual components in the (simulated) plant.

The results obtained from this approach give analysts a detailed understanding of facility behavior (e.g., as part of a power uprate evaluation), including the effects of potential SBO accident scenarios. With this new modeling capability, the impact of higher nominal reactor core power on the timing of specific events can be quantified. These safety insights provide useful information to decision makers for performing risk-informed margins management.

### References:

- Gaston, D. et al., 2009, "MOOSE: A Parallel Computational Framework for Coupled Systems of Nonlinear Equation," *Nuclear Engineering Design*, 239, 1768-1778.
- INL, 2012, *RELAP-7 Level 2 Milestone Report: Demonstration of a Steady State Single Phase PWR Simulation with RELAP-7*, INL/EXT-12-25924, Idaho National Laboratory, May 2012.
- INL, 2013, *RELAP-7 Level 2 Milestone Report: Demonstrating Seven-Equation, Two-Phase Flow Simulation in a Single-Pipe, Two-Phase Reactor Core and Steam Separator/Dryer*, INL/EXT-13-28750, Idaho National Laboratory, March 2013.
- INL, 2013a, *RELAP-7 Simulation Resolving an SBO Scenario on a Simplified Geometry of a BWR*, INL/EXT-13-29887, Idaho National Laboratory, August 2013.
- INL, 2013b, *Deployment and Overview of RAVEN Capabilities for a Probabilistic Risk Assessment Demo for a PWR Station Blackout*, INL/EXT-13-29510, Idaho National Laboratory, June 2013.
- INPO, 2011, *Special Report on the Nuclear Accident at the Fukushima Daiichi Nuclear Power Station*, INPO 11-005, November.
- NEA/NSC/DOC, 2001, "Boiling Water Reactor Turbine Trip (TT) Benchmark," Volume I: Final Specifications.
- U.S. Nuclear Regulatory Commission, *Reactor Concepts Manual*, Chapter 3, <http://www.nrc.gov/reading-rm/basic-ref/teachers/03.pdf>.

## Industry Engagement

The Advanced Instrumentation, Information, and Control (II&C) Systems Technologies Pathway conducts targeted research and development to address aging and reliability concerns with legacy instrumentation and control and related information systems of the U.S. operating light water reactor (LWR) fleet. This work involves two major goals: (1) to ensure that legacy analog II&C systems are not life-limiting issues for the LWR fleet, and (2) to implement digital II&C technology in a manner that enables broad innovation and business improvement in the nuclear power plant operating model. Resolving long-term operational concerns with II&C systems contributes to long-term sustainability of the LWR fleet, which is vital to the nation's energy and environmental security.

A key tenet of the Advanced II&C Systems Technologies Pathway is to continuously engage the nuclear power industry to ensure a correct understanding of the II&C issues and requirements *as currently experienced in the*



**Bruce P. Hallbert and Ken Thomas**  
Advanced Instrumentation, Information,  
and Control Systems Technologies Pathway

*operating nuclear power plants* and to develop approaches to address aging instrumentation and control systems and demonstrate them in individual pilot projects with operating nuclear power plants. This provides immediate validation of the developed technologies as fully meeting utility requirements. The results can be used by other utilities to address similar aging issues and to achieve new efficiencies. This approach is unique to this pathway and is essential, because future, planned research and development efforts are built on the concepts of and successes from prior

projects. This creates a stepwise approach to long-term modernization and refurbishment of instrumentation and control technologies across the LWR fleet. The engagement strategy with nuclear utilities serves to identify priorities for modernization and safety enhancement, timeframes for action, a means of coordinating resources and research partnerships, and a forum for communicating the results of the research efforts to the broader nuclear industry and vendor community.

**Figure 6. A Catawba Nuclear Station maintenance technician using wireless mobile worker technology to conduct valve maintenance.**



### ***II&C Utility Working Group***

Industry engagement is primarily accomplished through an II&C Utility Working Group (UWG). The UWG is composed of knowledgeable utility representatives who participate in formal meetings and conference calls to provide input on nuclear power plant needs, review development plans and technology prototypes, and provide input on objectives, research activities, and priorities for the Advanced II&C Systems Technologies Pathway. At this time, the UWG consists of 14 U.S. nuclear utilities, including Arizona Public Service, Constellation Energy, Duke Energy, Entergy, Exelon, First Energy, Luminant, Pacific Gas and Electric, Progress Energy, Southern California Edison, Southern Company, South Texas Project, Tennessee Valley Authority, and Xcel. These U.S. nuclear utilities represent over 70% of the U.S. LWR fleet. Additional UWG membership is being pursued, with the goal of involving every U.S. nuclear operating fleet in the program. The Electric Power Research Institute (EPRI) and the Halden Reactor Project also participate in the UWG.

UWG members serve as host utilities for pilot projects when their internal performance improvement objectives align with the goals of a particular pilot project. Host utilities make their facilities available for technology demonstrations and related studies. This involves participation by their staff in conducting plant activities using the developed technologies in highly controlled circumstances to avoid interactions with plant operations. Figure 6 shows an example of staff participation in a

recent pilot project at a host utility. Host utilities typically allow other nuclear utilities to observe the technology demonstrations as a means of obtaining wider industry review of the technologies and promoting broader awareness of the performance improvement potential. Host utilities also regularly make presentations in key industry technical meetings to describe their motivations and efforts in the pilot projects and to communicate important findings to the industry.

In 2013, several important meetings were held to engage the UWG. The first opportunity was a Workshop on New Capabilities for Nuclear Plant Productivity Improvement that was held jointly with EPRI in May 2013. The meeting focused on four areas: (1) future plant worker, (2) future plant control center, (3) future plant work automation, and (4) integrated operations. Specific requirements were collected for the underlying technologies of computer-based procedures, advanced outage control centers, online monitoring, and plant work automation (see Figure 7). In addition to the development work of the Advanced II&C Systems Technologies Pathway, related research efforts of EPRI and Halden Reactor Project were presented.

A second opportunity was the UWG Special Interest Group meeting on highly integrated control rooms held at the Bellefonte Nuclear Plant near Hollywood, Alabama. This meeting included 20 attendees associated

*Continued on next page*

***Figure 7. Advanced II&C Systems Technologies Pathway team members instructing staff at Palo Verde Nuclear Generating Station on use of the computer-based procedure prototype.***



*Continued from previous page*

with the UWG, along with host participants from Tennessee Valley Authority and AREVA. The purpose of the meeting was to review the instrumentation and control and control room modernization efforts at Bellefonte as part of Tennessee Valley Authority's restart of this deferred nuclear power plant project from the 1980s. The instrumentation and control system for Bellefonte is an all-digital design with a fully integrated control room. A full-scale mock-up of the main control room was demonstrated. This mock-up features a completely digital design with a 26-ft wide large display that is located in front of the operator and shift manager consoles. This meeting afforded the opportunity for the UWG to derive requirements and lessons-learned for application in the more incremental upgrades that are being undertaken in the operating LWR fleet.

The third opportunity was the 2013 Summer UWG Meeting that was held August 20, 21, and 22, 2013 at the Idaho National Laboratory. This was a joint meeting with the EPRI Strategy Group for productivity improvements through advanced technology and featured presentations and demonstrations on the current Advanced II&C Systems Technologies Pathway pilot projects, including the advanced outage control center, computer-based procedures, online monitoring, and incorporating digital upgrades in an analog control room. Members of the UWG were provided opportunities for hands-on use of pilot project technologies. The meeting included a

presentation by EPRI on their current efforts in technology development for nuclear power plants. Duke Energy made a presentation on control room upgrades for three of their nuclear power plants. The human factors engineering work for these control room modifications is being conducted as part of the II&C pilot project on incorporating digital upgrades in analog control rooms (see Figure 8). Also, the Halden Reactor Project staff made presentations on integrated system validation for control room upgrades and a summary of recent operator studies related to control room human factors. There were a total of 35 attendees for the meeting, representing both utilities and research organizations.

### **Broader Industry Engagement**

Each year, a number of industry engagement activities are conducted to more broadly communicate the work of the Advanced II&C Systems Technologies Pathway and to identify potential collaboration opportunities with other nuclear industry organizations where mutually beneficial.

Industry meetings and conferences are important opportunities to broadly engage various technical communities by presenting the developed technologies and directly addressing their requirements and concerns in panel discussions and question and answer sessions. These presentations often result in new relationships with organizations that desire to become more directly involved in the work of the pathway. The Advanced II&C Systems Technologies Pathway work was presented at six major industry meetings during 2013, including the

**Figure 8. Advanced II&C Systems Technologies Pathway team members conducting control room human factors work in the Idaho National Laboratory's Human Systems Simulation Laboratory with operators from Duke Energy's Harris and Brunswick nuclear plants.**





Human Factors and Ergonomics Annual Meeting, the Nuclear Long-Term Operations and Upgrades Conference, the International Society of Automation Power Industry Division Symposium, the nuclear industry's Annual Procedure Symposium, the annual Nuclear Information Technology Strategic Leadership Workshop, and the American Nuclear Society Utility Working Conference.

The nuclear industry relies heavily on a select group of industry support organizations to provide common approaches and solutions to common issues, including EPRI, the Nuclear Energy Institute, the Institute of Nuclear Power Operations, and the Nuclear Information Technology Strategic Leadership. Meetings or discussions were held with each of them during 2013 to make them aware of the technologies being developed, how they would enhance nuclear utility operations when implemented, and whether there are near-term opportunities to coordinate efforts where they intersect the respective interests of the Advanced II&C Systems Technologies Pathway and the particular industry support organization.

Notable for 2013 was a series of discussions held with the Institute of Nuclear Power Operations on potential

coordination of efforts in implementation of digital II&C technology in operating nuclear power plants. The Institute of Nuclear Power Operations proposed several means of collaboration, ranging from information exchange to direct engagement with utilities by participating in their instrumentation and control activities. These possibilities will be pursued as part of the 2014 industry engagement strategy.

### **Looking ahead to 2014**

In 2014, greater emphasis will be placed on communicating the work of the Advanced II&C Systems Technologies Pathway to nuclear utility decision makers to share understanding of the pathway goals and objectives and to better align the pathway's technical program plan to the highest industry priorities. Through this effort, it is expected that the pathway will deliver more near-term benefit to industry at a time when industry is challenged with cost pressures and new technical requirements, while continuing to build long-term value that will contribute to the sustainability of the LWR fleet as a reliable and cost-effective electric power generation source for the nation.

## **The Minerals, Metals and Materials Society Award**

**Professor G. Robert Odette**  
University of Santa Barbara  
Materials Aging and Degradation  
Pathway



University of California, Santa Barbara professor and Materials Aging and Degradation Pathway researcher G. Robert Odette has been named as a recipient of the 2014 Distinguished Scientist/Engineer Award given by the Structural Materials Division of The Minerals, Metals and Materials Society. With more than 12,000 members, The Minerals, Metals and Materials Society is the major professional society serving the field of structural materials research. This award recognizes a "long lasting contribution to the fundamental understanding of microstructure, properties, and performance of structural materials for industrial applications." Professor Odette is internationally recognized for his research in structural materials, especially for fission and fusion energy systems. His citation reads, "For seminal contributions to fundamental understanding of irradiation effects on materials and translation into predictive engineering models of materials performance." The award will be presented at The

Minerals, Metals and Materials Society Annual Meeting held in San Diego, California during February 2014.

Professor Odette is a pioneer in basic research on irradiation embrittlement of reactor pressure vessel steels, which is his focus in the LWRS Program's Materials Aging and Degradation Pathway. His research focuses on establishing new databases that provide mechanistic insight as the basis to develop advanced, multi-scale models that will provide robust predictions of embrittlement at 80 years or more extended life conditions. Professor Odette is a frequent invited speaker at international meetings and has authored or co-authored more than 270 technical publications, including 186 papers listed in the Web of Science and 30 in the archival ASTM International Special Technical Publication series. His honors and awards include the American Nuclear Society (ANS) Distinguished Achievement Award (Materials Science and Technology Division) in 1994, Fellow of ANS in 1998, the ANS Mishima Award in 1998, the ANS Outstanding Paper in the Field of Nuclear Materials in 2004 (Materials Science and Technology Division), the ANS Distinguished Achievement Award (Fusion Energy Division) in 2010, and a co-recipient of the ANS Special Achievement Award in 2010 (for his work on reactor pressure vessel embrittlement).

## Status of Silicon Carbide Joining Technology Development

### Shannon M. Bragg-Sitton

Advanced Light Water Reactor  
Nuclear Fuels Pathway



Advanced, accident tolerant nuclear fuel systems are being investigated for potential application in currently operating LWRs or in reactors that have attained design certification. An accident tolerant design would offer equivalent or better performance under normal operating conditions when compared to the current zirconium alloy-uranium dioxide fuel system, while offering increased safety in the event of accidents in the reactor or spent fuel pool. Evaluation of potential options for accident tolerant nuclear fuel systems point to the potential benefits of silicon carbide (SiC) relative to zirconium-based alloys, including increased corrosion resistance, reduced oxidation and heat of oxidation, and reduced hydrogen generation under steam attack (off-normal conditions). If demonstrated to perform acceptably in the LWR environment, SiC could be used in nuclear fuel cladding or other in-core structural components. A report summarizing SiC materials

considered for LWR applications, including an estimate of their current technology development status, benefits, and outstanding issues, was recently issued (Bragg-Sitton et al. 2013).

Investigations aimed at further determining the applicability of SiC in LWR applications continue to demonstrate the benefits of SiC materials relative to zirconium-based alloys. Preliminary analysis that applies the existing data on SiC properties suggests significant improvement in the reactor coping time through use of SiC materials versus zirconium-alloys under a selected loss-of-coolant-accident scenario (Merrill and Bragg-Sitton 2013). However, many data and technology gaps remain, particularly for SiC composite materials. A critical need for any technology involving SiC composites is development of a reliable joining methodology that can withstand the radiation environment inherent to an operating LWR.

The two primary design concepts using SiC composites that are considered for LWR cladding include fully ceramic SiC/SiC composite cladding and ceramic/metal "hybrid" cladding. Hermeticity (meaning impervious to gas) is a key functional requirement for any cladding design, both axially and at the end-cap seals. A fully ceramic cladding

**Figure 9. Oak Ridge National Laboratory joint development work: (a) Ti diffusion bonding showing uniform and intact bonding of two SiC substrates, and (b) miniature torsion specimens of Ti diffusion-bonded SiC joints prepared for irradiation study, following successful establishment of diffusion bonding technology with Ti or Mo active insert.**

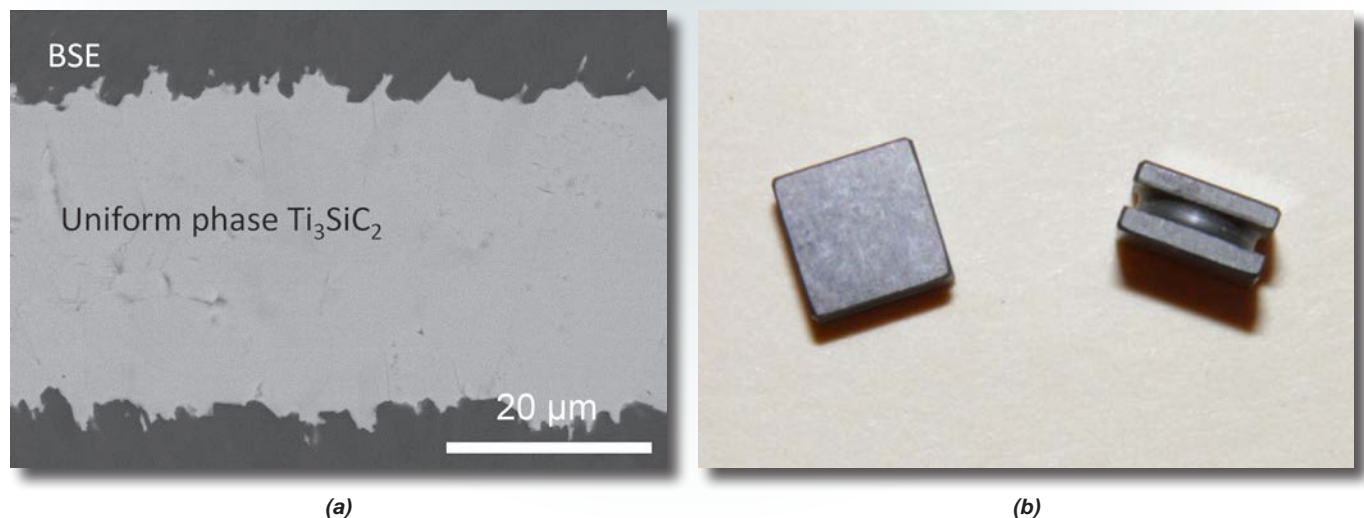

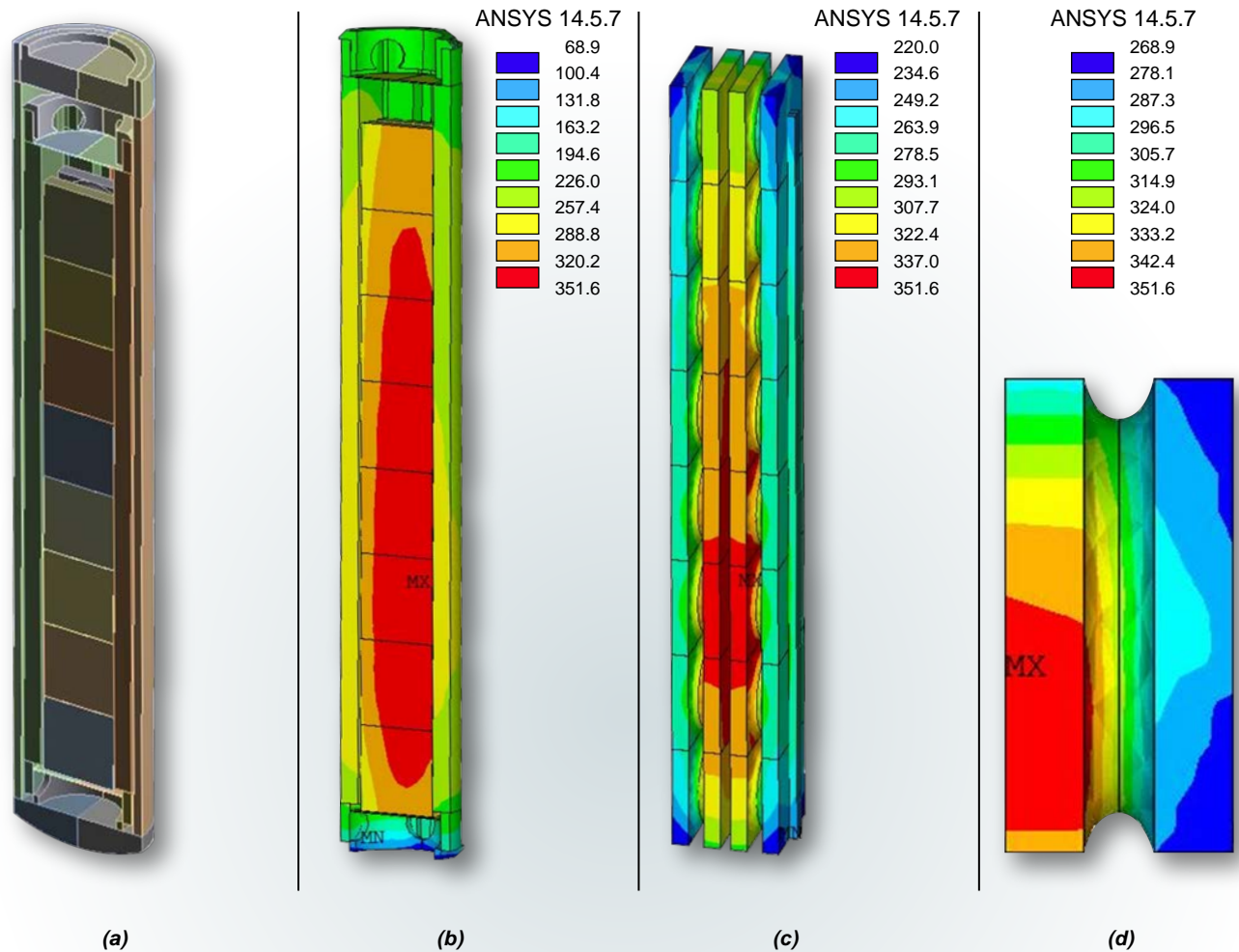

**Figure 10. (a) Three-dimensional model developed for thermal analysis of the High-Flux Isotope Reactor silicon carbide torsional joint rabbit capsules, (b) temperature distribution at inside surface of specimen stack, (c) temperature distribution of the entire specimen stack, and (d) temperature distribution within one of the hot specimens.**

could incorporate SiC fiber reinforced ceramic matrix composite to achieve fracture toughness (i.e., improved strength over zirconium-alloy cladding) in combination with a layer (or layers) of monolithic SiC ceramic to seal the composite structure, providing hermeticity along the length. The hybrid design concept is comprised of a composite layer or sleeve over an inner metallic liner tube (possibly zirconium-alloy, but other metals also could be considered). Various technical, operational, economic, materials interaction, and fabrication issues must be addressed for each design category.

Joining SiC to SiC is a key challenge that must be resolved before SiC can be used for either structural materials or nuclear fuel cladding in LWRs. The end-cap seal for the fully ceramic cladding system requires sealing of the SiC fiber reinforced ceramic matrix composite to itself. In the

hybrid cladding design, the hermetic seal for the fuel pin is provided by the inner metal liner; end caps also are welded on the metal liner, because they are standard for all-metal cladding designs. Joints in non-fuel SiC components must be reliable under LWR conditions; however, they do not have the same hermeticity requirements as fuel components.

A reliable, reproducible technique to join and hermetically seal SiC composites has been identified as a critical technology gap for SiC-based cladding systems. There are a number of conventional and advanced techniques to join SiC (or SiC/SiC composite) to itself or other materials. Successfully demonstrated techniques include pre-ceramic polymer joining, glass-ceramics, reaction bonding, active

*Continued on next page*



**Figure 11. Tested endplug joint geometries for cylindrical joint assemblies: (a) schematic of the scarf and butted scarf geometries inserted into the cylindrical cladding tube, and (b) as-fabricated monolithic silicon carbide butted scarf (left), scarf (middle), and butted lap endplugs.**

#### *Continued from previous page*

metal/pre-ceramic polymers, and active metal solid state displacement techniques (see Katoh et al. [2013a] for a summary of previous work). While the strength of the joints produced by these methods appears to be adequate for LWR applications, there currently is a lack of standards for testing ceramics, resulting in a variety of tests being applied to measure the strength of the bonds created using each technique.

Additionally, there currently is limited irradiation data on the joints and the materials used to fabricate the joints; many of the joint fabrication techniques that have been tested under irradiation have demonstrated poor irradiation stability. Given the functional requirement of hermeticity for nuclear fuel cladding that is necessary to retain helium and gaseous fission products, the SiC/SiC joining technique must be radiation stable for the relevant conditions of applied stress (specific stress condition has not yet been defined), temperature (approximately 300 to 500°C), and neutron damage (approximately 6 displacements per atom [dpa]). Recent positive results on SiC/SiC joining technologies are discussed in Katoh et al. (2013a).

Three research efforts were supported by the LWRS Program in 2013. Oak Ridge National Laboratory (ORNL), General Atomics, and Rolls-Royce High-Temperature

Composites (formerly Hypertherm High-Temperature Composites) led these projects; the industry projects were awarded via a competitive bid process. Ongoing work on SiC/SiC joint development has encouraged strong communications between the various institutions developing joint technology to ensure commonality of test techniques for future comparison of test results. Additionally, the LWRS Program supports involvement of ORNL SiC researchers in the ASTM International, formerly known as the American Society for Testing and Materials (ASTM), committees tasked with developing standards for ceramic composites intended for nuclear service.

#### **ORNL Joining Work**

Candidate joining technologies recently tested at ORNL were limited to those joints that provide low-induced radioactivity and include: titanium diffusion bonding (see Figure 9); Ti-Si-C  $M_{n+1}AX_n$  phase ceramic composition (MAX-phase) joining; calcia-alumina glass-ceramic joining; and transient eutectic phase SiC joining. All joints were evaluated for torsional shear strength, microstructures, and the effects of neutron irradiation at elevated temperatures.

All methods produced strong joints, having unirradiated torsional shear strength of approximately 100 MPa or higher. Joint samples have been irradiated in the High-Flux Isotope Reactor (HFIR) up to approximately 5 dpa at 500 or 800°C. Analysis of the results indicates that joint microstructure and mechanical properties compared well

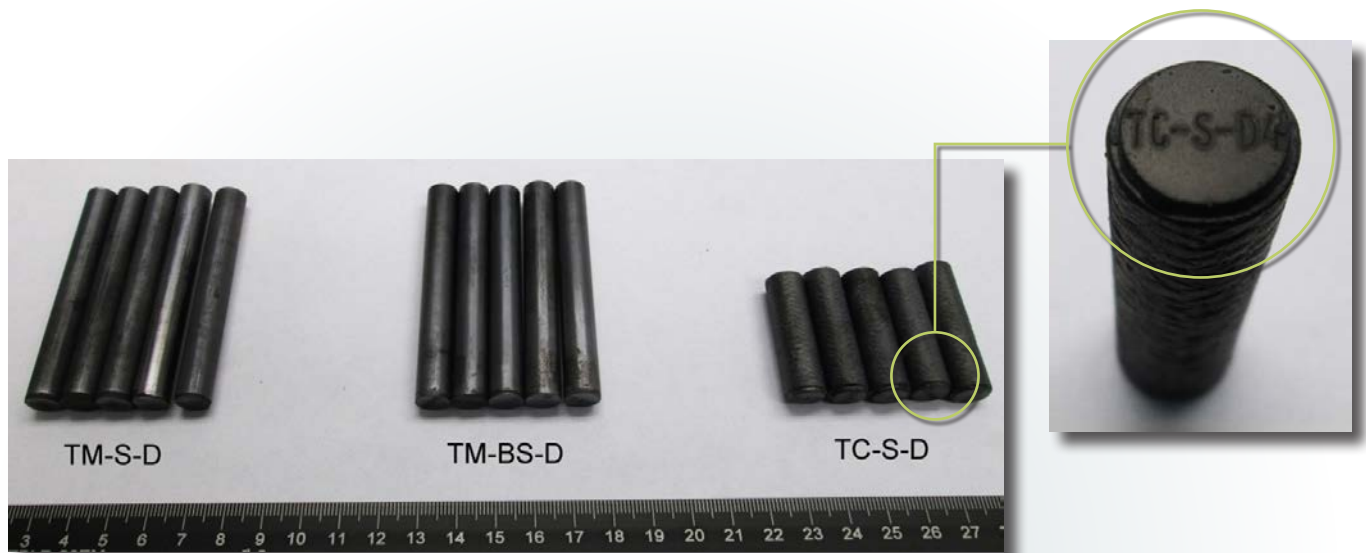

**Figure 12.** Image of the 15 joined tubular specimens, constituting the final deliverable sample set. As shown in the inset, each specimen was laser etched with its specimen name.

to pre-irradiation conditions. The Department of Energy Office of Science Fusion Materials Program supported this irradiation; therefore, the irradiation temperatures were somewhat higher than what is of interest to normal LWR operation. Within the limitations of statistics, all tested joints retained their joint mechanical strength after irradiation. However, the higher irradiation temperature may not provide a conservative estimate of performance under LWR conditions, because radiation damage in ceramics is often more severe at lower temperatures. This work provides the first positive results for irradiation-stable SiC joints. For the higher temperature irradiation conditions (800°C, approximately 5 dpa), some joint materials exhibited significant irradiation-induced microstructural evolution; however, the effect of irradiation on joint strength appeared rather limited.

A complete summary of the ORNL joint development status is included in Katoh et al. (2013b). In addition to fabricating SiC joint specimens, a polyethylene capsule (so-called rabbit capsule) has been designed and fabricated for joint irradiation in ORNL's HFIR. Currently, an initial irradiation study is planned for 2014 in an LWR-relevant temperature/dose condition for a selection of joint samples from ORNL and other SiC-SiC joint development teams. Figure 10 shows a thermal analysis performed in preparation for the HFIR rabbit capsule irradiation. The results of the three-dimensional analysis reveal a relatively large temperature distribution within the specimen stack;

however, the joint planes are maintained in a temperature range of 290 to 320°C for all specimens.

### **General Atomics**

General Atomics performed their SiC composite joining work under a 1-year contract. The General Atomics work progressed in three overlapping, increasingly complex phases: planar joints, cylindrical joints, and cylindrical joints between a monolithic endplug and a SiC-SiC composite tube.

Selection of a joint design must take into account leak rate performance, fabrication time, fabrication cost, and mechanical performance (e.g., strength). To safely and successfully deploy any joint in an LWR fuel system, the joint must be able to retain fission product gases and sustain a peak internal pressurization of 2,250 psi; this corresponds to 5,625 psi when a safety factor of 2.5 is applied. The leak rate requirement established for a viable joint is  $3 \times 10^{-8}$  atm-cc/sec at 300°C.

General Atomics initially performed a scoping study on planar joints to determine the most promising joint design. Planar joints of four geometries were prepared and fabricated and 23 joints were mechanically tested. Based on the test results, the most promising joint geometry was identified and targeted for the continued

*Continued on next page*

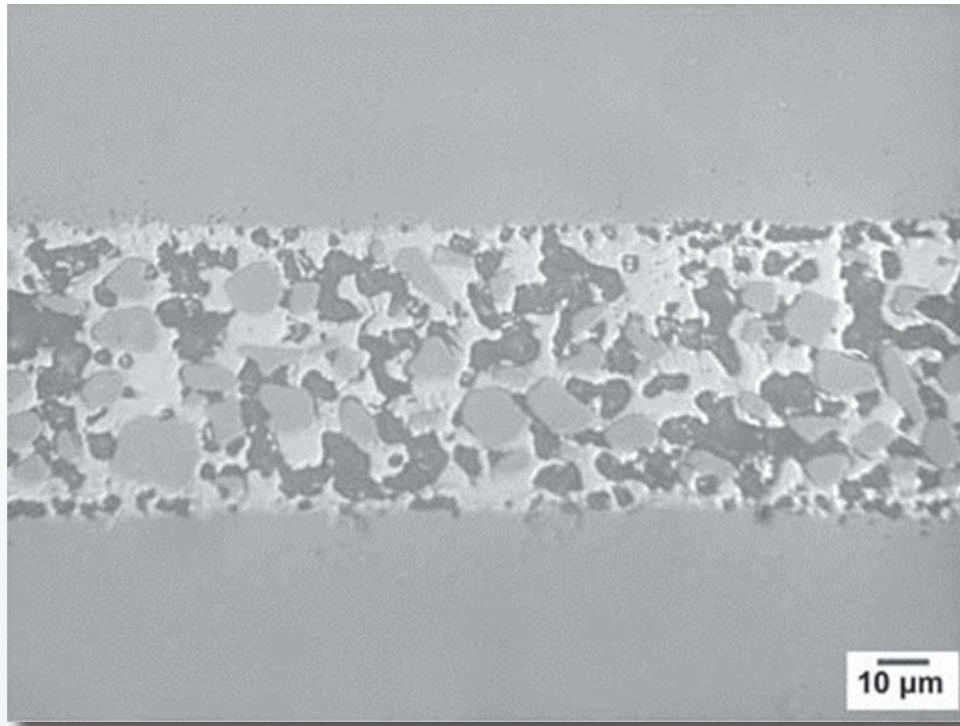

**Figure 13. MAX phase-based bond microstructure (Rolls-Royce High Temperature Composites).**

*Continued from previous page*

cylindrical geometry testing. Further data collected on monolithic  $\beta$ -SiC endplugs and tubes (cylindrical geometry) indicate that two candidate joint geometries are capable of meeting established performance requirements: the scarf and butted scarf geometries (see Figure 11). Both geometries surpassed the helium leak rate design specification of  $3 \times 10^{-8}$  atm\*cc/sec (at 300°C and 1 atm), and both geometries demonstrated endplug pushout failure loads in excess of 1.7 kN, meeting the internal pressurization requirement with a safety factor of 2.5 (Khalifa et al. 2013). The scarf geometry is comparably easier to fabricate, but requires additional SiC overcoating to meet the leak rate requirement. The butted scarf geometry is more complex to fabricate, but achieves suitably low leak rates with comparably less SiC overcoating. Both endplug geometries present viable solutions to the problem of nuclear grade joining; therefore, both were applied in the final phase of the General Atomics work, fabricating and testing joined cylindrical components with SiC-SiC composite cladding. The final task performed by General Atomics entailed fabrication of joints between monolithic SiC endplugs

and SiC-SiC composite tubes fabricated via chemical vapor infiltration. The fiber architecture residual porosity in SiC-SiC composites has the potential to impact joint integrity and performance. Fabricated composite assemblies surpassed the helium leak rate and the internal pressurization requirements for both the scarf and butted scarf geometries. A joined composite assembly exhibited no degradation in leak rate or mechanical performance after being thermally cycled to 1000°C and subsequently pre-loaded to 2,250 psi equivalent.

The permeability and endplug pushout testing of these joint assemblies provides compelling evidence that this joint material and these joint geometries are robust, resilient, and capable of sustaining the loads and conditions expected during LWR operation. Furthermore, testing has established that this new joining technology is applicable to both monolithic and composite components.

General Atomics completed the scope that was laid out in the 1-year contract (see Figure 12, joined tubular specimens). The recommended next steps to further develop and improve on the joint technology include expanding the data set. Thermal cycling results showed no degradation; however, the short contract period precluded longer cycling and the repeated tests that are necessary

to strengthen the database. Additional mechanical testing that was outside the scope of this contract (such as fatigue and fretting) also needs to be addressed. For deeper understanding to aid modeling efforts, a more instrumented and expanded endplug pushout test would be beneficial. Finally, irradiation testing is needed to verify joint robustness in the intended LWR operating environment.

### **Rolls-Royce High-Temperature Composites**

The Rolls-Royce High-Temperature Composites work is focused on demonstration of an impermeable joint using materials that are either known to be stable under the irradiation environment or currently are planned for investigation due to their promise. Joining will be conducted at temperatures that are compatible with nuclear grade SiC/SiC composites, whether reinforced with Tyranno SA or Hi-Nicalon Type S fibers. Joint evaluations at Rolls-Royce High-Temperature Composites will include mechanical, microstructural, and hermeticity measurements, with potential follow-on irradiation of the most promising joint technologies at HFIR. The Rolls-Royce High-Temperature Composites joint design employs a classic “leak before break” approach.

The envisioned joint design incorporates a monolithic pressure boundary (i.e., an adhesive-bonded joint, backed by a SiC matrix composite that can withstand the entire pressure requirements of the application structurally); however, it may not have the desired impermeability. Incorporation of a SiC matrix composite into the joint provides a degree of damage tolerance to the joined region. The SiC/SiC fuel cladding segments (tubes) to be used in the Rolls-Royce High-Temperature Composites study will be fabricated by overbraiding a monolithic SiC tube with a nuclear grade SiC fiber, Hi-Nicalon Type S. A nuclear grade SiC/SiC composite containing the nuclear grade SiC fiber is then formed. This design is believed to combine the best of a monolithic tube (impermeability) with the toughness and non-catastrophic failure of a composite.

Work at Rolls-Royce High-Temperature Composites began somewhat later than that at ORNL and General Atomics and is not yet complete. Evaluation of fuel cladding joint designs and definition of test coupons to evaluate material design parameters have been completed. A test matrix for preliminary screening of adhesive joining using both SiC and MAX-phase bonding has been outlined. Some initial mechanical testing has been conducted for a MAX-phase bonded sample, and initial trials for establishing a liquid phase sintered SiC bond have been performed. Microstructure of a MAX-phase-based bond is shown in Figure 13. Based on finite element modeling, the SiC bond has a more uniform stress distribution, with

lower maximum stress in both radial and hoop stress configurations. The assumed modulus and densities of the SiC bond more closely match the adherends and are theorized to be an overall benefit to the maximum stress levels. To achieve this lower stress state, a high-density/lower-porosity SiC bond is most desirable to achieve the preferred modulus matching. Work will continue to develop robust SiC-SiC joint technology at Rolls-Royce High-Temperature Composites through 2014.

### **Conclusions and Current Path Forward**

Achieving an SiC-SiC joint that resists corrosion with hot, flowing water; is stable under irradiation; and retains hermeticity is a significant challenge. Significant progress has been made toward SiC-SiC joint development for nuclear service, but additional development and testing work is required to present a candidate joint for use in nuclear fuel cladding. Preliminary irradiation testing of SiC-SiC joint samples is scheduled to begin in 2014 at the ORNL HFIR facility.

### **References:**

- Bragg-Sitton, S., D. Hurley, M. Khafizov, K. McHugh, B. Merrill, I. van Rooyen, R. Schley, Y. Katoh, and C. Shih, 2013, *Advanced Fuels Campaign: Silicon Carbide Gap Analysis and Feasibility Study*, INL/EXT-12-29728, FCRD-FUEL-2013-000223, Idaho National Laboratory.
- Katoh, Y., L. L. Snead, T. Cheng, C. Shih, W. D. Lewis, T. Koyanagi, T. Hinoki, C. H. Henager, and M. Ferraris, 2013a, “Radiation-Tolerant Joining Technologies for Silicon Carbide Ceramics and Composites,” *Journal of Nuclear Materials*, accepted October 1, 2013.
- Katoh, Y., J. O. Kiggins, C. Shih, T. Koyanagi, J. L. McDuffee, and L. L. Snead, 2013b, *Status of Silicon Carbide Joining and Irradiation Studies*, ORNL/TM-2013/273, Oak Ridge National Laboratory.
- Khalifa, H. E., C. P. Deck, C. L. Hill, and C. A. Back, 2013, *Evaluation of Joined Cylindrical Components for SiC-Based Advanced Reactor Fuel Cladding*, 10th Pacific Rim Conference on Ceramic and Glass Technology, San Diego, CA, June 2013.
- Merrill, B. J. and S. M. Bragg-Sitton, 2013, “SiC Modifications to MELCOR for Severe Accident Analysis Applications,” *2013 LWR Fuel Performance Meeting, Top Fuel 2013*, sponsored by the American Nuclear Society, Charlotte, NC, paper 8546, September.

## Recent LWRS Program Reports

### Materials Aging and Degradation

- **Corrosion and Stress Corrosion Crack Initiation of Cold-Worked Alloy 690 in PWR Primary Water**  
[https://lwrs.inl.gov/Materials%20Aging%20and%20Degradation/Cold-Worked\\_Alloy\\_690\\_M2LW-13OR0402035.pdf](https://lwrs.inl.gov/Materials%20Aging%20and%20Degradation/Cold-Worked_Alloy_690_M2LW-13OR0402035.pdf)
- **Evaluation of Ultrasonic Techniques on Concrete Structures**  
[https://lwrs.inl.gov/Materials%20Aging%20and%20Degradation/Ultrasonic\\_Techniques\\_M2LW-13OR0403035.pdf](https://lwrs.inl.gov/Materials%20Aging%20and%20Degradation/Ultrasonic_Techniques_M2LW-13OR0403035.pdf)

### Advanced Light Water Reactor Nuclear Fuels

- **Materials Inventory Database for the Light Water Reactor Sustainability Program**  
[https://lwrs.inl.gov/Advanced%20Light%20Water%20Reactor%20Nuclear%20Fuels/Materials\\_Inventory\\_Database\\_M3LW-13IN0502023.pdf](https://lwrs.inl.gov/Advanced%20Light%20Water%20Reactor%20Nuclear%20Fuels/Materials_Inventory_Database_M3LW-13IN0502023.pdf)

### Advanced II&C Systems Technologies

- **Computer-Based Procedures for Field Workers: Results from Three Evaluation Studies**  
[https://lwrs.inl.gov/Advanced%20IIC%20System%20Technologies/Computer\\_Based\\_Procedures\\_M2LW-13IN0603098.pdf](https://lwrs.inl.gov/Advanced%20IIC%20System%20Technologies/Computer_Based_Procedures_M2LW-13IN0603098.pdf)
- **A Reference Plan for Control Room Modernization: Planning and Analysis Phase**  
[https://lwrs.inl.gov/Advanced%20IIC%20System%20Technologies/Control\\_Room\\_Modernization\\_M2LW-13IN0603073.pdf](https://lwrs.inl.gov/Advanced%20IIC%20System%20Technologies/Control_Room_Modernization_M2LW-13IN0603073.pdf)
- **Summary Report on Industrial and Regulatory Engagement Activities**  
[https://lwrs.inl.gov/Advanced%20IIC%20System%20Technologies/Industrial\\_Regulatory\\_Engagement\\_M3LW-13IN0603055.pdf](https://lwrs.inl.gov/Advanced%20IIC%20System%20Technologies/Industrial_Regulatory_Engagement_M3LW-13IN0603055.pdf)
- **Development of Methodologies for Technology Deployment for Advanced Outage Control Centers That Improve Outage Coordination, Problem Resolution and Outage Risk Management**  
[https://lwrs.inl.gov/Advanced%20IIC%20System%20Technologies/Advanced\\_Outage\\_Control\\_Centers\\_M3LW-13IN0603103.pdf](https://lwrs.inl.gov/Advanced%20IIC%20System%20Technologies/Advanced_Outage_Control_Centers_M3LW-13IN0603103.pdf)

### Risk-Informed Safety Margin Characterization

- **Support and Modeling for the Boiling Water Reactor Station Black Out Case Study Using RELAP and RAVEN**  
[https://lwrs.inl.gov/RiskInformed%20Safety%20Margin%20Characterization/Black\\_Out\\_Case\\_Study\\_RELAP\\_RAVEN\\_M3LW-13IN0702015.pdf](https://lwrs.inl.gov/RiskInformed%20Safety%20Margin%20Characterization/Black_Out_Case_Study_RELAP_RAVEN_M3LW-13IN0702015.pdf)
- **Implementation of Changes to the EONY Model to Account for Extended Service Conditions and Late Blooming Phases for Reactor Pressure Vessel Steels**  
[https://lwrs.inl.gov/RiskInformed%20Safety%20Margin%20Characterization/EONY\\_Model\\_M3LW-13OR0704032.pdf](https://lwrs.inl.gov/RiskInformed%20Safety%20Margin%20Characterization/EONY_Model_M3LW-13OR0704032.pdf)
- **Grizzly Year-End Progress Report**  
[https://lwrs.inl.gov/RiskInformed%20Safety%20Margin%20Characterization/Grizzly\\_Year\\_End\\_M2LW-13IN07040110.pdf](https://lwrs.inl.gov/RiskInformed%20Safety%20Margin%20Characterization/Grizzly_Year_End_M2LW-13IN07040110.pdf)
- **Modeling of Late Blooming Phases and Precipitation Kinetics in Aging Reactor Pressure Vessel (RPV) Steels**  
[https://lwrs.inl.gov/RiskInformed%20Safety%20Margin%20Characterization/Modeling\\_Aging\\_RPV\\_Steels\\_M3LW-13IN0704019.pdf](https://lwrs.inl.gov/RiskInformed%20Safety%20Margin%20Characterization/Modeling_Aging_RPV_Steels_M3LW-13IN0704019.pdf)
- **RELAP-7 Simulation Resolving an SBO Scenario on a Simplified Geometry of a BWR**  
[https://lwrs.inl.gov/RiskInformed%20Safety%20Margin%20Characterization/RELAP-7\\_SBO\\_Scenario\\_M2LW-13IN0704014.pdf](https://lwrs.inl.gov/RiskInformed%20Safety%20Margin%20Characterization/RELAP-7_SBO_Scenario_M2LW-13IN0704014.pdf)
- **RELAP-7: Demonstrating Seven-Equation, Two-Phase Flow Simulation in a Single-Pipe, Two-Phase Reactor Core and Steam Separator/Dryer**  
[https://lwrs.inl.gov/RiskInformed%20Safety%20Margin%20Characterization/RELAP-7\\_Seven-Equation\\_Two-Phase\\_M2LW-13IN0704013.pdf](https://lwrs.inl.gov/RiskInformed%20Safety%20Margin%20Characterization/RELAP-7_Seven-Equation_Two-Phase_M2LW-13IN0704013.pdf)
- **Technical Basis Guide Describing How to Perform Safety Margin Configuration Risk Management**  
[https://lwrs.inl.gov/RiskInformed%20Safety%20Margin%20Characterization/Technical\\_Basis\\_Guide\\_M2LW-13IN0702013.pdf](https://lwrs.inl.gov/RiskInformed%20Safety%20Margin%20Characterization/Technical_Basis_Guide_M2LW-13IN0702013.pdf)

**Editor:** Teri Ehresman  
**Writer:** LauraLee Gourley  
**Designer:** David Combs

To submit information or suggestions, contact  
Cathy J. Barnard at [Cathy.Barnard@inl.gov](mailto:Cathy.Barnard@inl.gov).