

Light Water Reactor Sustainability

ACCOMPLISHMENTS REPORT

2014



U. S. DEPARTMENT OF
ENERGY

Braidwood Nuclear Generating Station located in Will County in northeastern Illinois, and operated by Exelon Nuclear, is a partner in an LWRS Program pilot project on online monitoring.



The mission of the Light Water Reactor Sustainability Program is development of the scientific basis, and science-based methodologies and tools, for the safe and economical long-term operation of the nation’s high-performing fleet of commercial nuclear energy facilities.

Contents

- Introduction** 3
- Research Pathways**
- Materials Aging and Degradation 4
- Risk-informed Safety Margin Characterization 14
- Advanced Instrumentation, Information and Control Systems Technologies ... 18
- 2015 Deliverables Preview** 24
- Program Contacts** 26



On the Cover

The Diablo Canyon Power Plant, located near Avila Beach in San Luis Obispo County, California, is a partner in an LWRS Program pilot project on computer-based procedures. (photo by Jim Zimmerlin, Pacific Gas & Electric Company)

Introduction

Welcome to the 2014 Light Water Reactor Sustainability (LWRS) Program Accomplishments Report, covering research and development highlights from 2014. The LWRS Program is a U.S. Department of Energy research and development program to inform and support the long-term operation of our nation's commercial nuclear power plants. The research uses the unique facilities and capabilities at the Department of Energy national laboratories in collaboration with industry, academia, and international partners. Extending the operating lifetimes of current plants is essential to supporting our nation's base load energy infrastructure, as well as reaching the Administration's goal of reducing greenhouse gas emissions to 80% below 1990 levels by the year 2050. The purpose of the LWRS Program is to provide technical results for plant owners to make informed decisions on long-term operation and subsequent license renewal, reducing the uncertainty, and therefore the risk, associated with those decisions.

In January 2013, 104 nuclear power plants operated in 31 states. However, since then, five plants have been shut down (several due to economic reasons), with additional shutdowns under consideration. The LWRS Program aims to minimize the number of plants that are shut down, with research and development that supports long-term operation both directly (via data that is needed for subsequent license renewal), as well as indirectly (with models and technology that provide economic benefits). The LWRS Program continues to work closely with the Electric Power Research Institute (EPRI) to ensure that the body of information needed to support Subsequent License Renewal (SLR) decisions and actions is available in a timely manner.

This report covers selected highlights from the three research pathways in the LWRS Program: Materials Aging and Degradation, Risk-Informed Safety Margin Characterization, and Advanced Instrumentation, Information, and Control Systems Technologies, as well as a look-ahead at planned activities for 2015. If you have any questions about the information in the report, or about the LWRS Program, please contact me, Richard A. Reister (the Federal Program Manager), or the respective research pathway leader (noted on pages 26 and 27), or visit the LWRS Program website (www.inl.gov/lwrs). The annually updated Integrated Program Plan and Pathway Technical Program Plans are also available on the LWRS website for those seeking more detailed technical information.



**Kathryn A. McCarthy, Director,
LWRS Program Technical
Integration Office**

Zion Nuclear Power Station was the third dual-reactor nuclear power plant in the Commonwealth Edison network and served Chicago and the northern quarter of Illinois. Retired in 1998, it is a source of research materials for the Materials Aging and Degradation pathway.



Materials Aging and Degradation

Research and development efforts in this pathway are developing the scientific basis for understanding and predicting long-term behavior of materials in nuclear power plants. This work will inform long-term operation decisions by providing data and methods to assess the performance of systems, structures, and components essential to safe and sustained nuclear power plant operations, including methods for monitoring and assessing degradation via nondestructive techniques, and advanced strategies for mitigating the effects of aging.

Research Highlights

The research and development in this pathway falls into five categories: reactor metals, concrete, cables, mitigation technologies, and cross-cutting research activities such as harvesting materials from the Zion Nuclear Power Station, which is being decommissioned. Select research and development highlights are provided here, followed by a list of major accomplishments (detailed reports covering the accomplishments can be found on the LWRs Program website, www.inl.gov/lwrs).

Reactor Metals

Numerous metal alloys can be found throughout the primary and secondary reactor systems. Some of these materials (in particular, the reactor core internals) are exposed to high temperatures, water, and neutron flux. This challenging operating environment creates degradation mechanisms in the materials that are unique to nuclear reactor service.

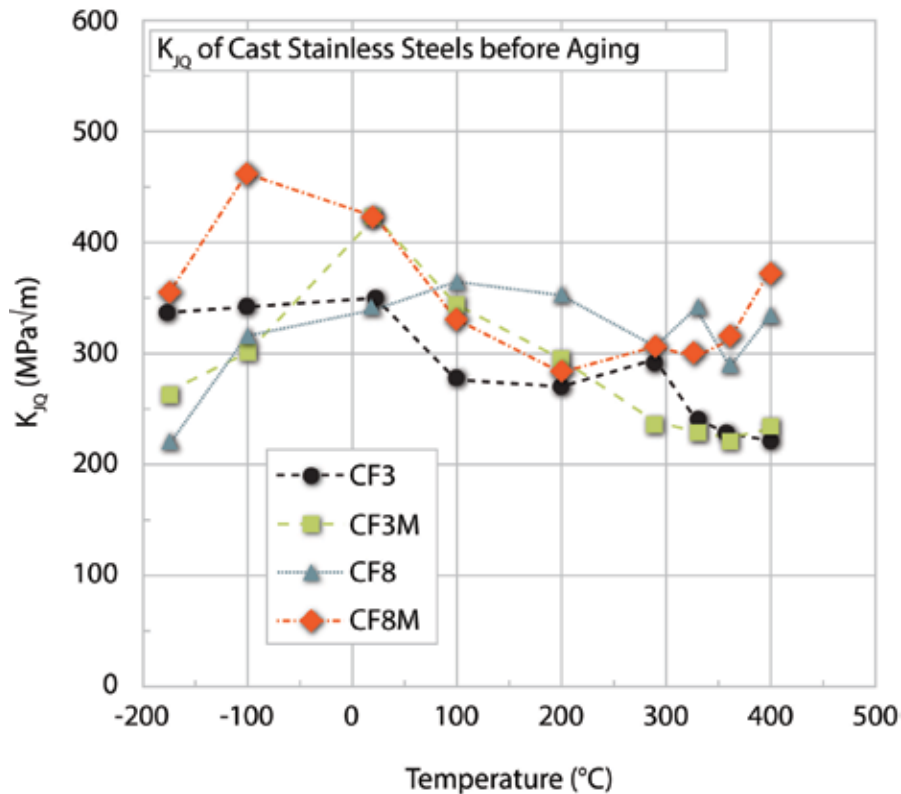

Fracture toughness tests on base cast austenitic stainless steels alloys prior to aging.

Reactor Metals Highlight:

Thermal Aging of Cast Austenitic Stainless Steel: Cast austenitic stainless steels (CASSs) are highly corrosion-resistant iron-chromium-nickel alloys with austenite single phase or austenite-ferrite duplex structure and have been used for a variety of applications in nuclear power plants. CASSs are important materials in modern LWR facilities since a large amount of the alloy is used in large volumes such as piping in reactor coolant systems. Relatively few critical degradation modes of concern are expected within the current design lifetime of 40 years when CASS components have been processed properly; today's fleet has experienced very limited failures or material degradation concerns. In the limited number of service observations of degradation, all have been attributed to some abnormal characteristics such as high carbon content, low ferrite content, or improper processing. Under extended service scenarios, there may be degradation modes to consider for CASSs. For example, prolonged thermal aging at up to 80 years is beyond the current databases and there could be decomposition of key phases and formation of other deleterious phases. Such aging could result in the loss of fracture toughness (analogous to that observed in other martensitic stainless steels). Additional surveys of potential phase changes and aging effects will reduce the uncertainty associated with these mechanisms. In this research task, the effects of elevated temperature service in CASS are being examined.

In 2014, Oak Ridge National Laboratory (ORNL) completed baseline mechanical tests and basic microstructural examination for model alloys (CF3, CF8, CF3M, and CF8M). The mechanical characterization includes fracture toughness tests (44 tests at -175 to 400°C), tensile tests (40 tests), and Charpy impact tests (52 tests). The tensile test

Work in 2014 included characterization of hold down spring material harvested from an operational reactor.



results indicate that both ductility and strength decrease with test temperature. Very high tensile strength (greater than 800 MPa) and high total ductility (greater than 70%) were measured at -100°C . Over the aging temperature region (290 to 400°C), strength and ductility are not temperature dependent, which indicates that the same deformation mechanism is responsible in the temperature region. A new simplified fracture test procedure that does not rely on using a clip gauge was applied to this testing campaign for model CASS bend bar specimens. For the fracture data analysis, modified curve normalization was established for the J-Resistance curve construction for the model alloys. Fracture toughness was determined from the J-R curves, and its dependence on test temperature was explored. No fracture toughness below $200\text{ MPa}\sqrt{\text{m}}$ was measured from the model CASS materials. Peak fracture toughness was observed at room temperature or -100°C , below which K_{JQ} decreased with temperature but never reached brittle or lower shelf region. In each material, the change in fracture toughness was limited over the aging temperature region examined (290 to 400°C). Characterization of these starting materials is an essential step that will help provide insights into the aging performance of this key piping material.

Reactor Metals Highlight:

Irradiation Embrittlement in High Strength Nickel Alloys. Under irradiation, the large concentrations of radiation-induced defects will diffuse to defect sinks such as grain boundaries and free surfaces. These concentrations are in far excess of thermal-equilibrium values and can lead to coupled-diffusion with particular atoms. In engineering metals such as stainless steel, the very high fluences expected in PWR components during extended service could lead to irradiation-induced phase transformations and potentially swelling of core internals. To understand high-fluence effects on microstructural evolution, ORNL has been conducting research on selected

materials subjected to a variety of high dose damage levels. This work has included collaborative characterization with Areva and EPRI on harvested leaf spring materials.

In 2014, ORNL, with input from the industry partners, examined the microstructural and mechanical properties to determine possible root cause of failures in alloy 718 material following PWR service to > 45 MWd/mTU burn-up. Differences in materials of different batches and fabrication processes which resulted in less or no reported leaf spring failures following reactor service were examined via microhardness, nano-indentation, tensile and bend tests. Samples produced via focused ion beam (FIB) milling were examined via Electron Backscatter Diffraction analysis/Scanning Electron Microscopy (EBSD/SEM) to investigate the regions near the cracked material. Metallography and Transmission Electron Microscopy (TEM) were done to support the mechanical and EBSD work.

The studies showed that different mechanical cutting/grinding methods for fabricating springs have little effect on the surface microstructure that is influencing in-service properties. Possible sources of crack nucleation such as machined edges were ruled out. Slight differences in the heat treatment schedule have a larger impact, influencing the amount of precipitation along grain boundaries. A dense network of tiny secondary cracks was observed near the main stress corrosion cracks in the alloy 718 hold down springs. Most of such secondary cracks are believed to be intra-granular, and their formation was probably caused by oxidation of the slip lines. This research provides essential insights for radiation-induced changes in mechanical properties, which could affect the operation-life of LWRs.

Reactor Metals Highlight:

Mechanisms of Irradiation-Assisted Stress Corrosion Cracking. Over the forty-year lifetime of a LWR, internal structural components may expect to see up to approximately 10^{22}

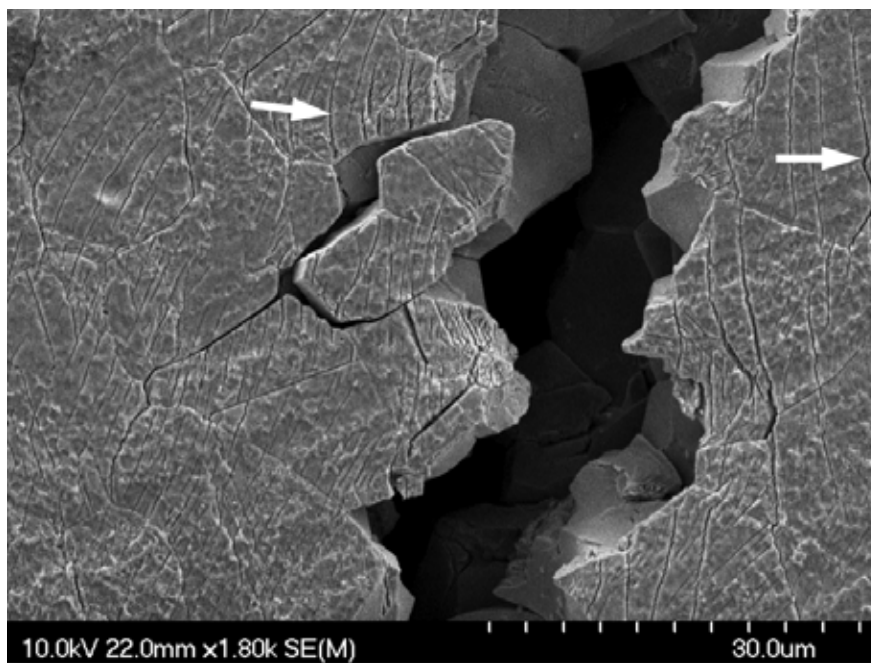

A dense network of tiny secondary cracks was observed near the main stress corrosion cracks in the alloy 718 hold down springs. Most of such secondary cracks (white arrows) are believed to be intra-granular. Their formation was probably caused by oxidation of the slip lines.

Researchers are exploring the development of in-situ techniques to understand the role of localized deformation in crack initiation in irradiated materials. Finite Element Analysis is done in parallel with the experimental work.

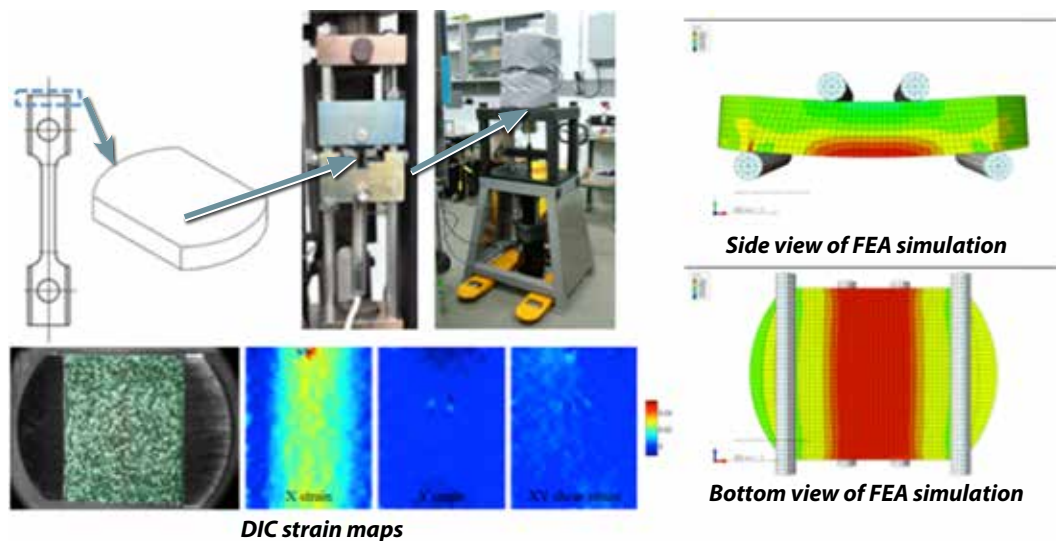

$n/cm^2/s$ ($E > 1$ MeV) in a boiling water reactor (BWR) and approximately 10^{23} $n/cm^2/s$ in a pressurized water reactor (PWR), corresponding to approximately seven displacements per atom (dpa) and 70 dpa, respectively. Extending the service life of a reactor will increase the total neutron fluence to each component, and when coupled with elevated temperatures, stress, and corrosive environment, the potential for increased susceptibility to irradiation-assisted stress corrosion cracking (IASCC) must be considered. IASCC has received considerable attention over the last four decades due both to its severity and unpredictability. Despite over thirty years of international study, the underlying mechanism of IASCC is still unknown. The objective of this LWRs Program work, which is jointly funded with EPRI, is to evaluate the response and mechanisms of IASCC in austenitic stainless steels with single-variable experiments.

Recent research has focused on the role of localized deformation in crack initiation in irradiated materials. This is a complex characterization challenge. Dislocation channels and cracking can be characterized following straining in water and while this information is useful, it does not positively link localized deformation and cracking. In-situ characterization will be required, but this is a very challenging problem. Researchers at the University of Michigan are exploring the development of in-situ techniques. A strain measurement technique has been selected for four point bend tests in high temperature water, using a row of micro hardness indents as fiducial marks. The indents are offset to the edge of the bend sample, to avoid stress concentration and crack initiation in the region of interest near the bend sample center. Using this technique, tensile strain measured near the edge of the bend sample is nearly identical to that near the sample center. Strain measurements from the same regions using both digital image correlation and indent spacing were also in agreement, although a larger degree of error was observed in the indent spacing measurements. This technique is now being deployed on the first neutron-irradiated sample to be tested (stainless steel at 10.2 dpa). If successful, this new tool could revolutionize our understanding of the mechanics of crack-initiation in irradiated stainless steels.

Concrete

Many concrete-based structures are part of a typical LWR plant, such as the foundation, support, shielding, and containment. Concrete has been used in nuclear power plant construction because of its low cost, ease of fabrication, its structural strength, and its ability to shield radiation. Examples of concrete structures important to LWR safety include the containment building, the spent fuel pool, and cooling towers. As concrete ages, changes in properties occur as a result of continuing microstructural changes (e.g., slow hydration, crystallization of amorphous constituents, and reactions between cement paste and aggregates), as well as environmental influences. Further changes are predicted due to interactions with radiation fields.

Concrete Highlight:

Effects of neutron radiation on mechanical properties of concrete. The changes in concrete properties have been considered minimal to the integrity of concrete structures in nuclear power plants for the fluences that might be experienced over 40 years of operation, however the database to support this has been limited. Extending the concrete database is important to support long-term operation. Current understanding of radiation effects on concrete up until now has been based largely on the “Hilsdorf curve” dating back to 1978. ORNL completed an expanded literature search in 2014 with the objective to expand the database and to attempt to identify possible first-order deleterious effects in irradiated concrete. The updated data agree with the

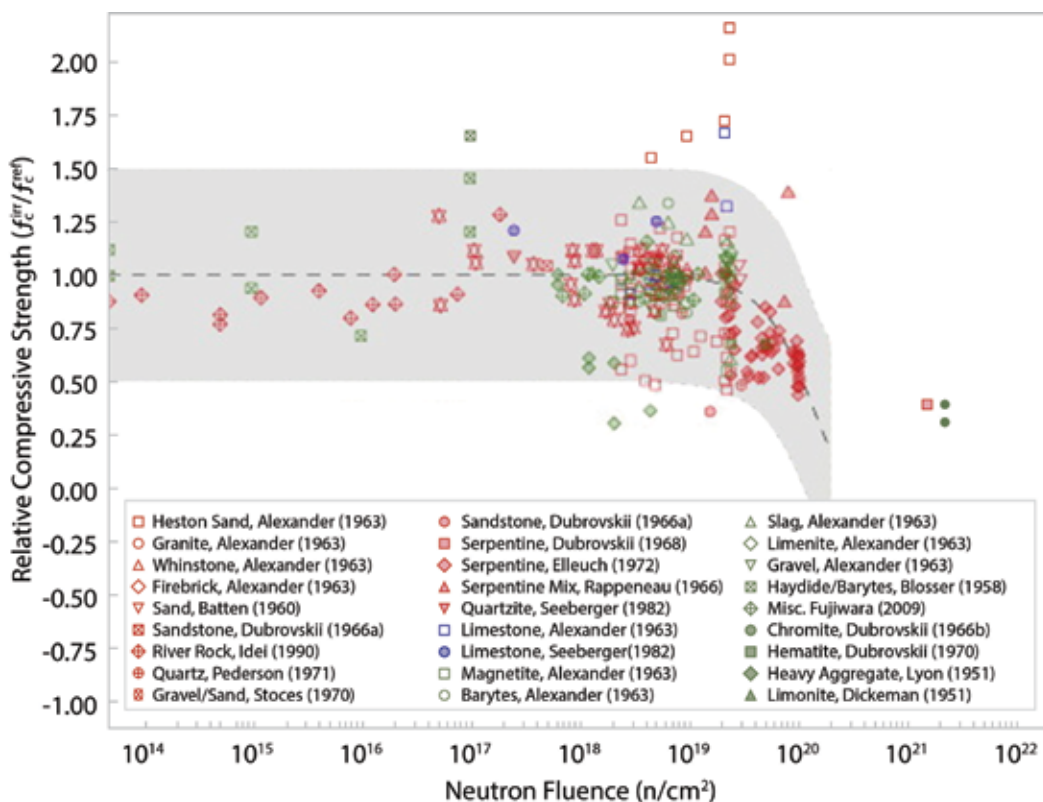

Relative compressive strength of concrete and mortar specimens versus neutron fluence. The neutron spectrum and specimen temperature vary between experiments. Siliceous concrete is depicted with red symbols, calcareous with blue, and miscellaneous concretes with green. Filled symbols indicate experiments conducted above 100°C; open symbols indicate experiments conducted below 100°C.

The technical feasibility of a new friction stir weld process was demonstrated.

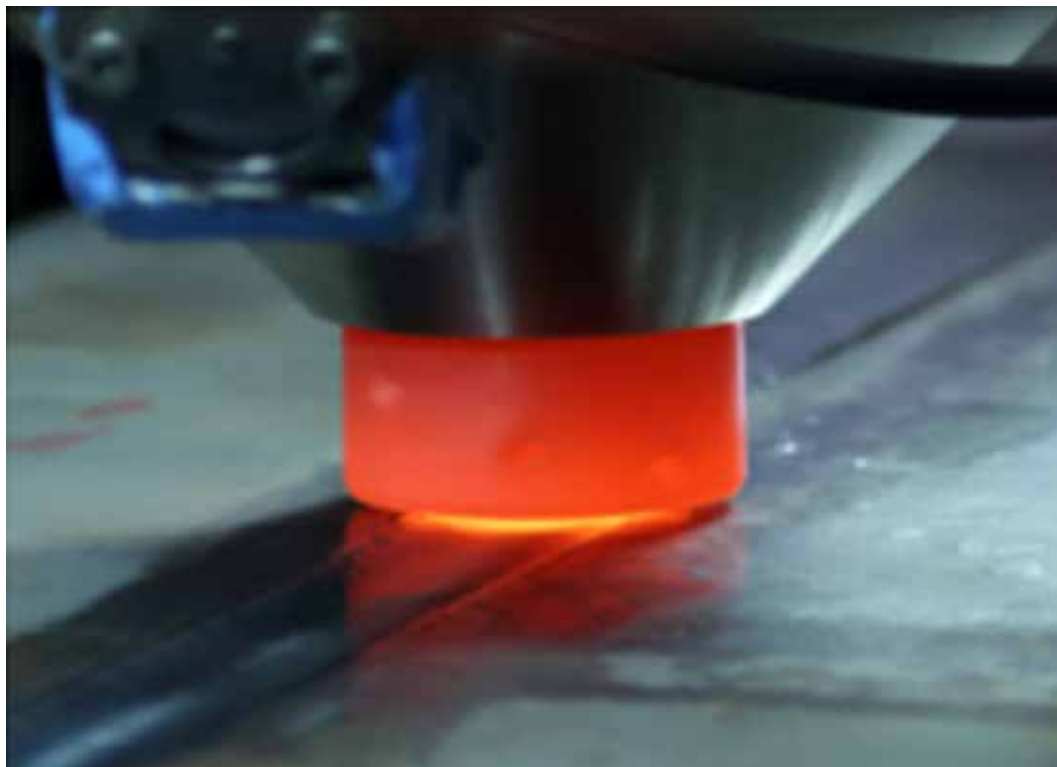

downward sloping trend in the relative compressive strength with increasing neutron fluence presented by Hilsdorf. This database, together with mechanistic modeling, will support the development of a predictive model for concrete degradation. The established database has provided detailed insight into the degradation modes in irradiated concrete and serves as a focusing element for key issues to be researched which will facilitate extended service of concrete structures in LWRs.

Advanced Weld Repair

Welding is widely used for component repair, and weld-repair techniques must be resistant to long-term degradation mechanisms such as corrosion and irradiation. The LWRS Program is developing new welding and weld analysis techniques for welding highly irradiated material via a combination of experimental and modeling activities that are jointly funded with EPRI. Understanding the impact that helium, present in irradiated material, has on the welding process is an important input to development of an advanced technology. The welding technology will be transferred to industry in 2018, providing an important repair technology that in some instances could enable repair rather than replacement of costly components. New mitigation tools may ultimately allow for in-situ repair of cracked core internal components.

Advanced Weld Repair Highlight:

In 2014, ORNL demonstrated the technical feasibility of a new friction stir weld process that can potentially allow for repairing highly irradiated, high-helium materials. The goal is to minimize the stress and heat effect to the helium-containing irradiated

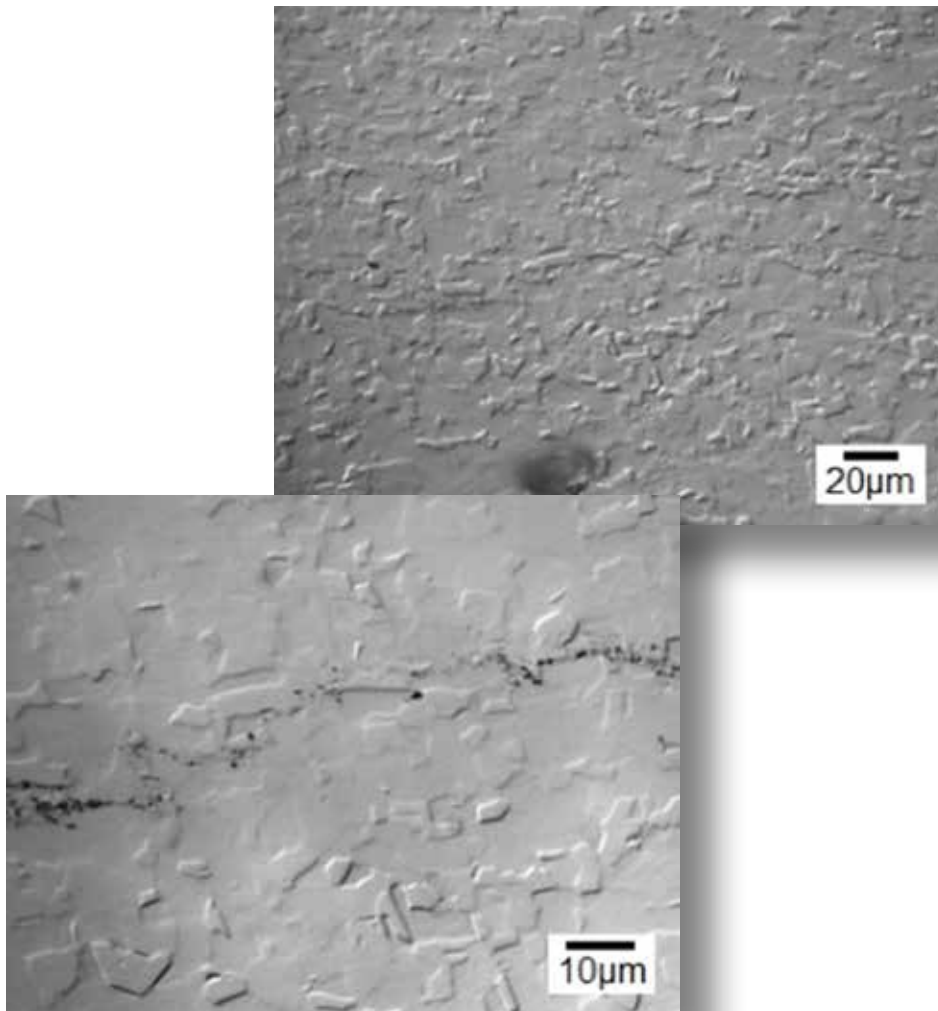

The bonding region from the friction stir weld shows minimal deformation and materials flow, but process improvement is needed to eliminate/disperse surface oxides.

materials, with the potential to repair at helium concentration levels much higher than today's repairable levels.

Harvesting Service Materials from Nuclear Reactors

Access to service materials from active or decommissioned nuclear power plants is invaluable because there is limited operational data or experience to inform relicensing decisions. In addition, access to service materials will facilitate coordination with other materials tasks, including an assessment of current degradation models to further develop the scientific basis for understanding and predicting long-term environmental degradation behavior.

Materials Harvesting Highlight:

The LWRS Program, in collaboration with the U.S. Nuclear Regulatory Commission (NRC), EPRI, and the U.S. nuclear industry, is engaged in harvesting materials from the Zion Nuclear Power Station. The Zion Harvesting Project, in cooperation with Zion Solutions, LLC, is coordinating the selective procurement of materials, structures,

components, and other items of interest to the LWRS Program, ERPI, and NRC from the decommissioned Zion Nuclear Power Station Units 1 and 2. In addition, the Zion Harvesting Project includes coordinating access to perform limited onsite testing of certain structures and components. Materials of high interest include low-voltage cabling, concrete core samples, and through-wall thickness sections of a reactor pressure vessel (RPV). Harvesting of the first RPV material is expected in 2015. Access to these materials is important and may improve understanding of RPV performance and validation of models and predictive tools.

2014 Materials Aging and Degradation Accomplishments

A summary of the 2014 Materials Aging and Degradation Pathway accomplishments is provided below. For each research area, the major 2014 accomplishments follow the primary out-year deliverable that they support.

Reactor Metals

- Deliver validated model for transition temperature shifts in RPV steels (2016)
 - Completed post-irradiation examination plan for ORNL and University California Santa Barbara assessment of ATR-2 capsules
 - Completed comprehensive and comparative analysis of atom probe tomography and small-angle neutron scattering experiments on available high fluence RPV steel specimens
 - Completed assessment of embrittlement effects in a RPV nozzle
- Deliver predictive capability for swelling in LWR components (2016)
 - Completed examination of the microstructural and mechanical properties to determine possible root cause of failures in alloy 718 material
 - Completed development of refined microstructural model for radiation-induced swelling in high fluence core internals
- Deliver predictive model capability for nickel-base alloy stress corrosion cracking susceptibility (2019)
 - Measured stress corrosion cracking initiation response in alloy 690 including effects of cold work, surface damage and dynamic strain
- Deliver model of precipitate phase stability and formation in Alloy 316 (2017)
 - Completed phase transformation studies in solute addition alloys
- Deliver predictive model capability for IASCC susceptibility (2019)
 - Completed crack growth rate studies of solute addition alloys and comprehensive analysis of crack growth rate as a function of solute addition and commercial microstructure-controlled alloys
 - Developed test matrix and irradiation test plan to address the potential loss of efficiency of hydrogen water chemistry to mitigate IASCC in BWR at high fluence
 - Developed initial correlation between localized deformation and IASCC response using bend tests

- Deliver predictive capability for cast stainless steel components under extended service conditions (2018)
 - Completed mechanical testing and microstructural analysis for pristine cast stainless steel materials

Cables

- Deliver predictive model for cable degradation (2019)
 - Completed integration plan for joint cable research with EPRI and other stakeholders
 - Completed assessment of experimental work for determining key indicators in aged cables for correlation to nondestructive examination (NDE) techniques

Concrete

- Complete concrete and civil infrastructure toolbox development including prototype of concrete NDE system (2018)
 - Completed design of large-scale concrete mockup to study the effects of alkali-silica reaction on shear fracture propagation in stress-confined safety related structures
 - Completed assessment of radiation induced aggregate swelling as a degradation mode in irradiated concrete structures
 - Completed preliminary conceptual design of a thick concrete NDE specimen
 - Developed a unified parameter for characterization of ionizing radiation intended for evaluation of radiation-induced degradation of concrete
 - Completed initial investigation of improved volumetric imaging of concrete using an advanced processing technique

Mitigation Technologies

- Complete transfer of weld-repair technique to industry (2018)
 - Completed construction of the enclosure for the dedicated welding hot cell
 - Completed the first batch of irradiation experiments to produce helium-containing SS304 samples for use in development of weld repair techniques
- Complete development and testing of new advanced alloy with superior degradation resistance (2024)
 - Completed analysis of microstructure and basic properties of the procured advanced alloys for the advanced radiation resistant materials program

Cross-Cutting Research Activities

- Completed Final Expanded Materials Degradation Assessment
- Identified concrete cores for acquisition from Zion Unit 2

Risk-Informed Safety Margin Characterization

The purpose of the Risk-Informed Safety Margins Characterization (RISMC) Pathway research and development is to support plant decisions for risk-informed margins management with the aim to improve economics, reliability, and sustain safety of current nuclear power plants over periods of extended plant operations. The goals of the RISMC Pathway are twofold: (1) develop and demonstrate a risk-assessment method that is coupled to safety margin quantification that can be used by nuclear power plant decision makers as part of risk-informed margin management strategies; (2) create an advanced RISMC Toolkit that enables more accurate representation of nuclear power plant safety margins.

Research Highlights

Select research and development highlights are provided here, followed by a list of major accomplishments (detailed reports covering the accomplishments can be found on the LWR Program website: www.inl.gov/lwrs).

RISMC Toolkit Development

The RISMC Toolkit consists of a set of software tools that are used to perform the analysis steps in the RISMC method. The tools under development take advantage of advances in computational science and are based on a modern framework: the Multi-Physics Object Oriented Simulation Environment (MOOSE) developed at Idaho National Laboratory (INL). These modern tools enable more efficient and more accurate modeling than is afforded by legacy tools.

RISMC Toolkit Development Highlight:

Grizzly, the materials aging and component degradation model is being developed jointly under the Materials Aging and Degradation and Risk-Informed Safety Margin Characterization Pathways to predict materials aging and component degradation for LWR plant structures and components. The first model under development is for aging of the RVP. RVPs are a primary, critical,

Global model of RPV showing location of submodel where detailed flaw geometry was introduced (blue small region on left side in figure on left). The base material is colored gray, and the liner material is colored green. The figure on the right side shows the distribution of accumulated neutron fluence after 32 years of operation.

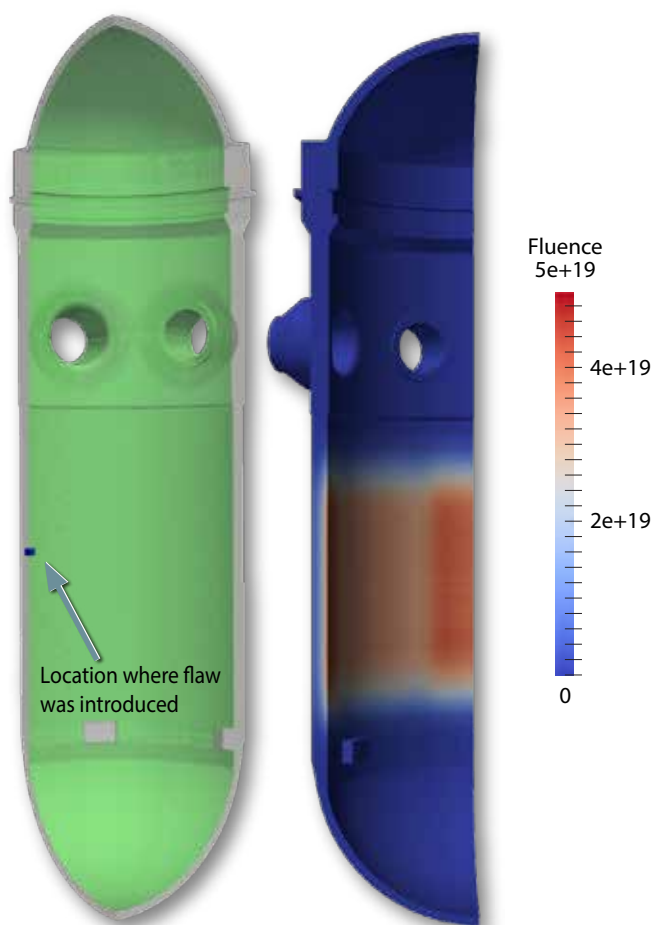

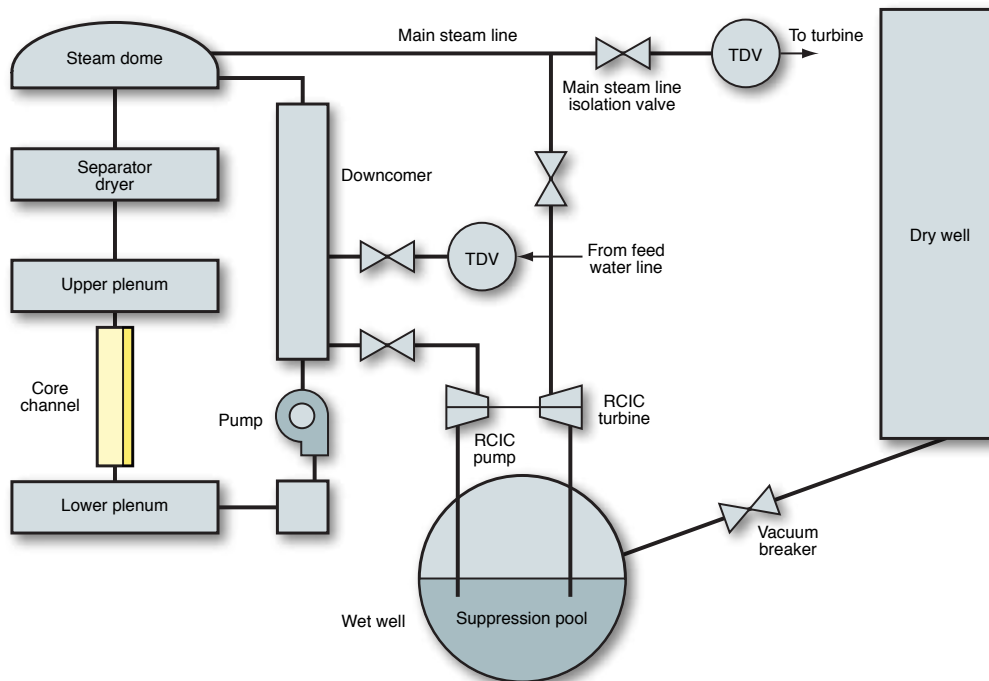

The BWR plant system model for Scenario II simulations using RELAP-7's seven-equation two phase flow core channel model.

safety-related component in nuclear power plants, and they represent a key line of defense against radiation release in an accident scenario. Thus, regulations that govern the operation of commercial nuclear power plants require conservative margins of fracture toughness for the RPV materials, both during normal operation and under accident scenarios. Should operational limits be reached, repairing or replacing a RPV is not practical, yet its mechanical integrity must be conservatively demonstrated for service life. This key component has a robust database of performance history across the fleet, providing data essential for validation of Grizzly.

In a pressurized thermal shock loading event in a RPV, there is concern that the low temperature would decrease the fracture toughness such that the loading-induced stress concentrations at pre-existing flaws in the wall could result in crack growth and propagation and potentially lead to a breach in the RPV wall. The stress concentrations at crack tips can be evaluated in finite element simulations using detailed models of the geometry of the cracks if the stress and temperature profiles through the wall can be modeled. In 2014, INL and the University of Tennessee extended Grizzly capabilities to enable 3D evaluation of domain integrals at crack tips in the presence of thermal loading. This allows for detailed deterministic analysis of the stress intensity factors along crack tips. This provides a way to assess the risk of crack growth at an existing flaw.

A beta version of Grizzly for evaluating RPV embrittlement will be released in 2015.

RISMC Toolkit Application

The RISMC Toolkit has progressed to the point where it can be applied to demonstration problems to illustrate the benefits from the RISMC methodology, using the modern computing tools under development in the LWR Program and other Department of Energy programs.

RISMC Toolkit Application Highlight

Station Blackout Scenario Analysis: In 2014, INL applied the RISMC methodology and toolkit (including RELAP-7) to analyze a detailed station blackout scenario. The scenario was built from the specifications documented in an Organization for Economic Cooperation and Development (OECD) benchmark problem for BWR turbine trip analysis. The reference design for the benchmark problem was from the Peach Bottom-2 nuclear station, which is a General Electric BWR-4 design. The demonstration case included the major components for the primary system of a BWR, as well as the safety system components for reactor core isolation cooling (RCIC), safety relief valve (SRV), check valve, and the wet well of a BWR containment. Two scenarios for the station blackout simulations were analyzed. Scenario I represented an extreme station blackout accident with no safety injection functioning, resulting in rapid dry out of the core. Scenario II represented a more probable station blackout accident progression with the RCIC and SRV systems continuing to function. In this scenario, the unique capabilities of RELAP-7 were demonstrated with the RCIC and SRV systems being fully coupled with the reactor primary system and the safety injection to provide makeup-cooling water to the reactor core from the suppression pool. As expected, the continued operation of the RCIC and SRV systems significantly postpones core dryout when compared to the results from Scenario I.

The fully-coupled simulation capabilities demonstrated with RELAP-7 have significant implications in terms of providing the RISMC Pathway with a high-fidelity deterministic tool for studying the effects of important safety parameters such as the battery lifetime, net positive suction head of the RCIC pump, and the impact of offsite power recovery time.

RISMC Toolkit Application Highlight

Detailed demonstration case study for emergent issue. In 2014, INL applied the RISMC toolkit to a complex hypothetical scenario to demonstrate the RISMC methodology. The analysis focused on two highly relevant topics currently facing the U.S. nuclear power industry, power uprates and flooding issues. This application looked at challenges to a hypothetical PWR, including: (1) a power uprate, (2) a potential loss of off-site power followed by the possible loss of all diesel generators (i.e., a station blackout event), (3) earthquake induced station blackout, and (4) a potential earthquake induced tsunami flood. The analysis was performed using RELAP-7 (thermal hydraulics), NEUTRINO (a flooding simulation tool), and RAVEN (a stochastic analysis tool), all of which are under development within the RISMC pathways (note that RAVEN is jointly developed by the LWRS Program and, the Nuclear Energy Advanced Modeling and Simulation (NEAMS) Program). Using RAVEN, INL performed multiple RELAP-7 simulation runs by changing specific parts of the model to reflect specific aspects of different scenarios, including both the failure and recovery of critical components. The simulation employed traditional statistical tools (such as Monte-Carlo sampling) and more advanced machine-learning based algorithms to perform uncertainty quantification to understand changes in system performance and limitations as a consequence of power uprate. Qualitative and quantitative results obtained gave a detailed picture of the issues associated with power uprate for a station blackout accident scenario. The analysis quantified how the timing of safety-related events is impacted by a higher reactor core power. These types of insights can provide useful material for decision makers to perform risk-informed margins management.

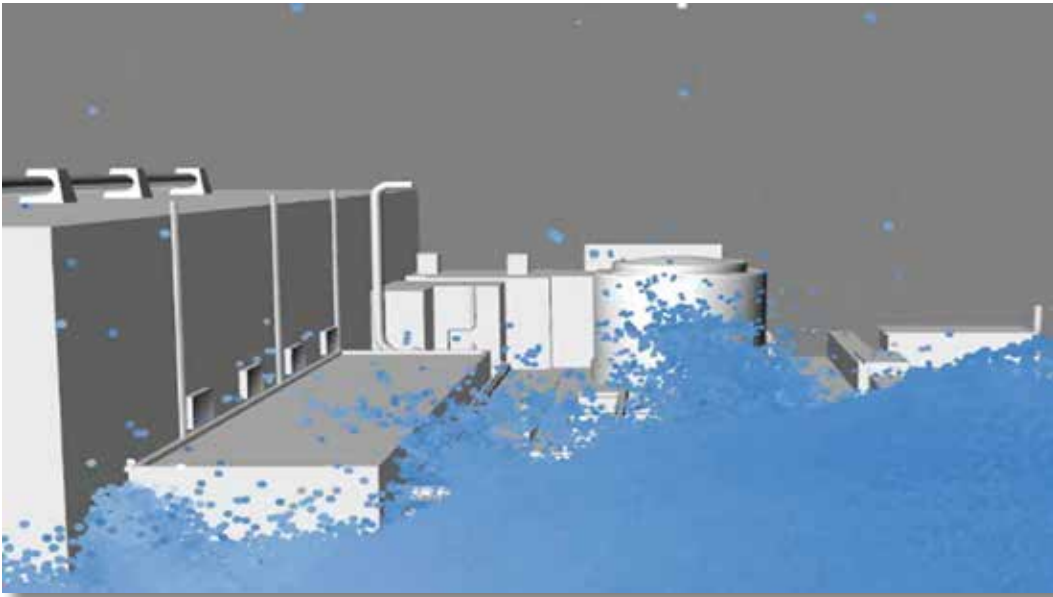

The NEUTRINO flooding simulation tool is a new addition to the RISMC Toolkit.

2014 Risk-Informed Safety Margin Characterization Accomplishments

A summary of the 2014 RISMC Pathway accomplishments is provided below. For each research area, the major 2014 accomplishments follow the primary out-year deliverable that they support.

- RELAP-7 and the margins analysis techniques and associated tools are an accepted approach for safety analysis support to plant decision-making (2020)
 - Completed RELAP-7 Theory Manual
 - Tested RISMC methodology using a LWR case study for enhanced accident-tolerance design changes
 - Completed detailed demonstration case study for an emergent issue using RAVEN and RELAP-7
 - Completed report of demonstration of nonlinear seismic soil structure interaction and applicability to new system fragility curves
 - Completed the preliminary design plan covering requirements, development, and important physics for severe accident analysis
 - Documented the approach and results obtained from the modeling and simulation for accident tolerant fuel under accident conditions
 - Completed RISMC case study for external event tolerant design changes
 - Completed RELAP-7 subchannel flow capability development.
 - Completed the RELAP-7 verification and validation plan
 - Completed report on more detailed BWR station blackout simulations
 - Developed approach for models that will be used to represent concrete degradation in Grizzly

Advanced Instrumentation, Information, and Control Systems Technologies

Efforts in the Advanced Instrumentation, Information, and Control (II&C) Systems Technologies Pathway seek to address safe and efficient modernization of the current instrumentation and control technologies used in nuclear power plants through development and testing of new instrumentation and control technologies and advanced condition monitoring technologies for more automated and reliable plant operation. The research and development products are used to design and deploy new II&C technologies and systems in existing nuclear power plants that provide an enhanced understanding of plant operating conditions and available margins and improved response strategies and capabilities for operational events. The goals are to enhance nuclear safety, increase productivity, and improve overall plant performance. Pathway researchers work with nuclear utilities to develop instrumentation and control technologies and solutions to support the safe and reliable life extension of current reactors.

Research Highlights

Select research and development highlights are provided here, followed by a list of major accomplishments (detailed reports covering the accomplishments can be found on the LWRs Program website: www.inl.gov/lwrs).

Pilot Projects

The Advanced II&C Systems Technologies Pathway has planned a series of capability-building pilot projects for developing and testing new technologies and capabilities, and that can be replicated and used by other nuclear power plants. Each pilot project has value individually, as well as collectively, by demonstrating the means to achieve long-term sustainability of II&C systems and technologies.

The Nuclear Energy Institute awarded a Top Industry Practice (TIP) award to Arizona Public Service for the outage control center technology in May 2014.



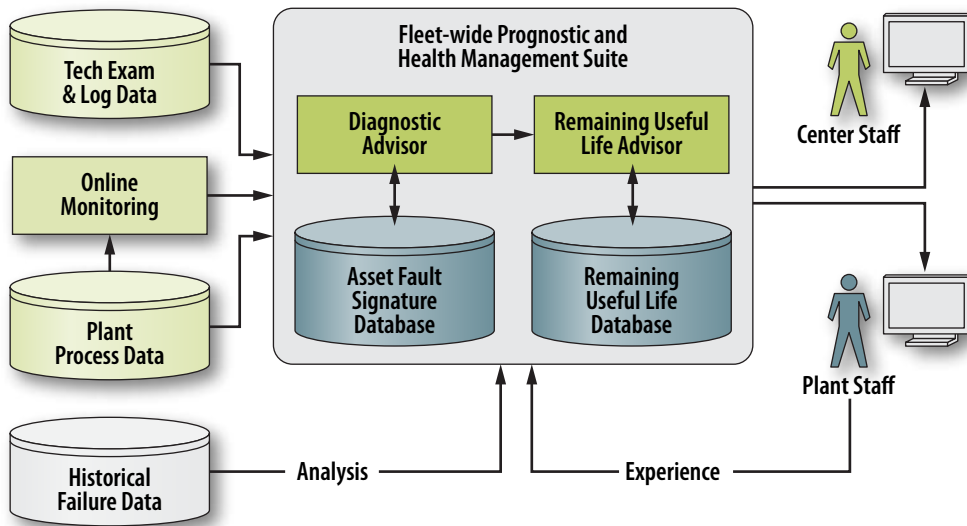

Data flow in the EPRI Fleet-wide Prognostic and Health Management Suite.

Pilot Project Highlight:

Advanced Outage Control Center. Managing nuclear power plant refueling outages is a complex and difficult task due to the large number of maintenance and repair activities that are accomplished in a relatively short period of time. During a refueling outage, the Outage Control Center (OCC) is the temporary command center for outage managers and provides several critical functions for successful execution of the outage schedule. The OCC provides vital information inflow, assists outage management with processing information, and disseminates information to plant staff, contractors, and other centers on- and off-site. Currently, outage management activities primarily rely on telephone communications, face-to-face reports, and daily briefings. It is difficult to maintain current information related to outage progress and any discovered conditions. One of the few remaining areas where significant improvement in plant capacity factors can be made is by minimizing the duration of refueling outages.

Palo Verde Nuclear Generating Station (PVNGS) has hosted several LWR Program pilot project activities. The Nuclear Energy Institute awarded a Top Industry Practice (TIP) Process Award for Materials, Management Processes, and Support Services to Arizona Public Service Company for leveraging technology to improve outage coordination and performance. The award was for an innovative process improvement employed by PVNGS in collaboration with INL researchers from the LWR Program to manage and provide enhanced collaboration of information and activities associated with PVNGS's 2013 refueling outage.

During PVNGS's fall refueling outage, a leak was discovered on a reactor vessel bottom-mounted instrumentation penetration. A similar bottom-mounted instrumentation issue had been experienced at South Texas Project. The time from issue identification to repair at South Texas Project was about 72 days. Use of operating experience, vendor support, and enhanced communication, facilitated by this new technology allowed the PVNGS to complete similar repairs in about 32 days. The additional cost avoided by reducing the outage extension from the previous benchmark was estimated at \$48M. Several PVNGS managers involved in resolution of the bottom-mounted

instrumentation issue said that the improved collaboration tools helped them achieve success in issue resolution.

Pilot Project Highlight

Online Monitoring of Active Components. As nuclear power plants age it is important to understand the condition of components and be proactive in their maintenance and replacement to improve plant reliability and productivity, and to reduce operational costs. The inability to identify developing faults can lead to unexpected component failure and forced outages. Implementing advanced predictive online monitoring will minimize undetected faults, enhance plant safety and system reliability by enabling plant engineers to detect and diagnose incipient faults before they affect plant availability. This technology will also be used to estimate the remaining useful life of important capital assets so that refurbishments and replacements of long lead-time items can be performed without impacting plant operations.

Research and development efforts for online monitoring of active components focused on diagnostic and prognostic models for generator step-up transformers (GSUs) in 2014. INL worked with subject matter experts from EPRI to augment and revise the GSU fault signatures previously implemented in the Asset Fault Signature Database of EPRI's Fleet-Wide Prognostic and Health Management (FW-PHM) Suite software. Two GSU prognostic models for the paper winding insulation, the Chendong and Institute of Electrical and Electronic Engineers thermal models were implemented in the Remaining Useful Life Database of the FW-PHM Suite. The Chendong model is based on the functional relationship between the degree of polymerization of the winding insulation and the 2-Furaldehyde concentration in the insulating oil. Degree of polymerization is one of the most commonly used metrics to assess the health of a transformer. The Institute of Electrical and Electronic Engineers thermal model is based on thermal profiling of the transformer. By utilizing transformer load information and ambient temperature, established thermal models are used to estimate the hot spot temperature inside the transformer, which in turn is used to compute transformer winding insulation lifetime. The resulting model was used to demonstrate estimation of remaining useful life of transformer winding insulation using both prognostic models.

Pilot Project Highlight

Computer Based Procedures. Improving procedures use could yield significant savings through increased worker efficiency and safety. Work activities in the nuclear power industry are guided by procedures, which today are printed and executed on paper. Paper-based procedures have served the nuclear industry well; however, industry recognizes the many improvements that remain to be gained. Because of its inherent dynamic nature, a computer-based procedure (CBP) provides the opportunity to incorporate task-based job aids, such as drawings, photos, and just-in-time training. Compared to the static state of paper-based procedures (PBPs), the presentation of information in CBPs can be much more flexible and tailored to the task, actual plant condition, and plant mode. The dynamic presentation of the CPB can guide the user down the path of relevant steps, minimizing time spent by field workers to evaluate plant conditions and make potentially difficult decisions related to the applicability of each step. Augmenting worker domain knowledge with automated procedure tools also minimizes the risk of conducting steps out of order or incorrectly assessing the applicability of conditions to procedural steps.



An auxiliary operator at Duke Energy's Catawba Nuclear Station conducts a digital correct component verification using the CBP System.

INL performed three evaluation studies in 2014: two at the PVNGS (one field evaluation study and one laboratory evaluation study), and one at Duke Energy's Catawba Nuclear Station. These studies support the development of design requirements for computer-based work instructions. The laboratory evaluation study allowed the researchers to demonstrate and test advanced functionality for the CBP prototype technology such as handling continuous action steps, automated calculations and further testing the dynamic context-sensitive presentation with the CBP prototype. The two field evaluation studies enabled researchers to identify and resolve a wide variety of issues related to using real-world work instructions that are more complex compared to the procedures used for the laboratory studies. The second field evaluation at PVNGS informed the development of an underlying data structure for computer-based work instructions that can apply to both operations procedures and work orders. Future efforts will expand the scope of the data structure to include all types of work instructions used by field workers in nuclear power plants.

Previous research has indicated that CBPs might be effective in reducing the number of errors operators commit. This laboratory evaluation study provided further evidence that CBPs may reduce errors with data demonstrating that operators committed half as many errors when using the CBP as with a PBP. The study also provided the first evidence that

CBPs can enhance performance without increasing the amount of time it takes to execute the procedure. The field evaluations demonstrated that the CBP system can be used in a real-world context with actual procedures. The field evaluations have also demonstrated that the CBP concepts for operations procedures can be translated to work orders.

II&C Research Highlight

Control Room Modernization. As control rooms are modernized with new digital systems at nuclear power plants, it is necessary to evaluate the operator performance using these systems as part of a verification and validation process. There are no standard, predefined metrics available for assessing what is satisfactory operator interaction with new systems, especially during the early design stages of a new system. In 2014, INL researchers identified the process and metrics for evaluating human system interfaces as part of control room modernization, including background information on design and evaluation, a thorough discussion of human performance measures, and a practical example of how the process and metrics have been used as part of a turbine control system upgrade during the formative stages of design. The process and metrics are geared toward adaptation to other applications and serve as a template for utilities undertaking their own control room modernization activities.

2014 Advanced Instrumentation, Information, and Control Systems Technologies Accomplishments

A summary of the 2014 Advanced II&C Systems Technologies Pathway accomplishments is provided below. For each research area, the major 2014 accomplishments follow the primary out-year deliverable that they support.

- Complete report on application of prognostic models for active components in nuclear power plants (2015)
 - Developed diagnostic and prognostic models for generator step-up transformers
 - Developed probabilistic health monitoring framework and demonstrated problem of aging concrete structures
- Deliver a health risk management framework for concrete structures in nuclear power plants (2018)
 - Completed interim report on the results of the concrete degradation mechanisms and online monitoring techniques survey.
- Deliver computer-based procedures that enhance worker productivity, human performance, plant configuration control, risk management, regulatory compliance, and nuclear safety margin (2015)
 - Completed computer based procedures validation study with nuclear power plant personnel
 - Developed requirements for control room computer based procedures
- Deliver an end-state vision and strategy, based on human factors engineering principles, for the implementation of both a hybrid and a more highly integrated

control room as new digital technologies and operator interface systems are introduced into traditional control rooms (2016)

- Developed operator performance metrics for use in control room modernization projects
- Completed human factors engineering design phase report for control room mode
- Developed a methodology for conducting baseline human factors and ergonomics review using a host nuclear power plant control room
- Complete Control Room Upgrades Benefit Study Plan describing the study methodologies, industry partners, cost, schedule, facilities, and resources
- Deliver a real-time outage risk management strategy to improve nuclear safety during outages by detecting configuration control problems caused by work activity interactions with changing system alignments (2019)
 - Identified advanced outage functions, including the results of the real-time support task involving coordination and automated work status updating
- Develop human factors evaluations and an implementation strategy for deploying automated field activity work packages built on mobile technologies, resulting in more efficient and accurate plant work processes, adherence to process requirements, and improved risk management (2016)
 - Developed the requirements for automated work package technologies for a sample of nuclear power plant work processes
- Implemented software tools in the Human Systems Simulation Laboratory that enable fully functional hybrid control room systems
- Completed cyber security program evaluation exercise for the pilot project technologies

2015 Deliverables Preview

Building on the successes achieved in 2014, the LWRS Program has laid out an aggressive set of deliverables for 2015.

Materials Aging and Degradation

- Reactor Metals
 - Fracture toughness tests of mini-disc compact specimens for RPV irradiation studies
 - Establish capacity to determine surface strain in four point bend tests conducted in a BWR normal water chemistry performance
 - Comparative analysis of small angle neutron scattering experiments from High Flux Isotope Reactor and the National Institute of Standards and Technology
 - Measure stress corrosion cracking initiation response in alloy 600 materials
 - Preliminary analysis of materials harvested from Ginna baffle bolts
 - Post-irradiation examination and localized deformation studies on key specimens to support IASCC studies
 - Analyze effect of thermal aging on the mechanical behavior and microstructure of cast stainless steels
 - Examine the effect of swelling on IASCC growth rate
 - Evaluate primary water stress corrosion cracking resistance of aged Alloy 690
- Concrete
 - Using a simplified model and statistical analysis, analyze structural significance of irradiation on the biological shield
 - Advanced numerical model for irradiated concrete
 - Guidelines for modeling irradiated concrete structures: physical description, governing equation and recommendation for implementation in Grizzly
 - Identify options to obtain service-irradiated concrete from a nuclear power plant such as Zion, Barseback or Zorita
 - Post-irradiation evaluation of the effects of fluence and temperature on swelling of mineral analogues of aggregates
 - Define a unified parameter for characterization of radiation for evaluation of radiation-induced degradation of concrete
 - Advanced alkali-silica simulation of nuclear structures
- Cables
 - Scoping design study on optimum configuration for combined thermal/radiation of cable samples at High Flux Isotope Reactor Gamma Irradiation Facility
 - Assess key indicators of aging cable insulation for signals supporting new non-destructive examination methods
 - Complete mechanical performance testing of treated insulation following rejuvenation treatments
- Preliminary analysis of inverse temperature effects, submerged cables, diffusion limited oxidation and dose rates
- Assess state-of-the-art NDE techniques for cable aging

Cable rejuvenation is a potential bridging technology for owner/operators until replacement begins.



High surface form of insulation material.



Accelerated aging of insulation material.

- Mitigation Technologies
 - Complete tensile and fracture toughness testing of select advanced radiation-resistant alloys
- Cross-Cutting Research Activities
 - Harvest two RPV segments from Zion Unit 2
 - Receive cables exposed to various environmental conditions from Zion Unit 2

Risk-Informed Safety Margin Characterization

- RISMC Toolkit
 - Survey of current simulation and non-simulation based human reliability models and recommended model approach
 - Beta release 1.0 of RELAP-7 and initial verification and validation
 - RAVEN User's Manual
 - Deterministic RPV fracture mechanics and stress behavior using crystal plasticity models in Grizzly
 - Identify models for aging mechanisms in concrete for Grizzly
 - Seismic fragility modeling
- RISMC Applications
 - Problem statement for integrated cladding/emergency core cooling system acceptance
 - Problem statement for industry application based on external hazard analysis

Advanced Instrumentation, Information and Control Systems Technologies

- Cyber security program evaluation of pilot project technologies
- Fully functional hybrid control room systems in the Human Systems Simulation Laboratory
- Control room upgrade benefits study
- Distributed control room prototype for turbine control system upgrade
- Operator performance metrics for verification and validation
- Requirements for control room CBPs
- Field evaluations and demonstrations of the automated work package prototype system and plant surveillance and communication framework requirements at host utilities
- Implement prognostic software for control indicators in the Human Systems Simulation Laboratory
- Prognostic models for online monitoring for active components
- Gap analysis on current typical instrumentation and controls and information technology capabilities versus digital architecture requirements
- Techniques for use in structural health framework for alkali-silica reaction damage in online monitoring of concrete structure
- Improved graphical displays for an Advanced Outage Control Center
- Verification and validation of a digitally upgraded control room in the Human Systems Simulation Laboratory
- Field evaluation of the upgraded prototype CBPs
- Digital architecture requirements for information technologies to support modernized plant work activities.

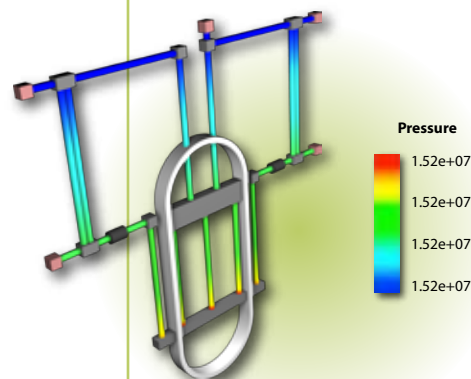

The beta 1.0 version of RELAP-7 will be released in 2015

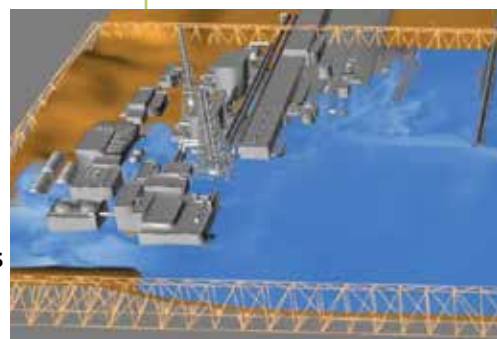

Simulation-based RISMC application for external hazard analysis.



Eye tracking can help assess and demonstrate the benefits of new control room technologies.

Light Water Reactor Sustainability Contacts

Program Management



Richard A. Reister

Federal Program Manager
Light Water Reactor Deployment
Office of Nuclear Energy
U.S. Department of Energy
richard.reister@nuclear.energy.gov
(301) 903-0234

Technical Integration



Kathryn A. McCarthy

Technical Integration Office Director
Idaho National Laboratory
kathryn.mccarthy@inl.gov
(208) 526-9392



Donald L. Williams

Technical Integration Office Deputy Director
Oak Ridge National Laboratory
williamsdljr@ornl.gov
(865) 574-8710



Cathy J. Barnard

Technical Integration Operations Officer
Idaho National Laboratory
cathy.barnard@inl.gov
(208) 526-0382

"The federal government's role is to support the sustainability of the nation's nuclear energy facilities by providing the science to enable the long-term safe, clean, and reliable operation of this important energy source through its unique facilities and expertise at DOE's national laboratories."

- **Richard Reister**
Federal Program Manager

Research and Development Pathway Leads



Materials Aging and Degradation

Jeremy T. Busby
Oak Ridge National Laboratory
busbyjt@ornl.gov
(865) 241-4622



Instrumentation, Information & Control Systems Technologies

Bruce P. Hallbert
Idaho National Laboratory
bruce.hallbert@inl.gov
(208) 526-9867



Risk-informed Safety Margin Characterization

Curtis L. Smith
Idaho National Laboratory
curtis.smith@inl.gov
(208) 526-9804



THE LIGHT WATER REACTOR SUSTAINABILITY PROGRAM

NRC



Nuclear Industry



DOE National Labs



Universities

*Working together to ensure energy security through the technically validated
extended operation of nuclear power plants*