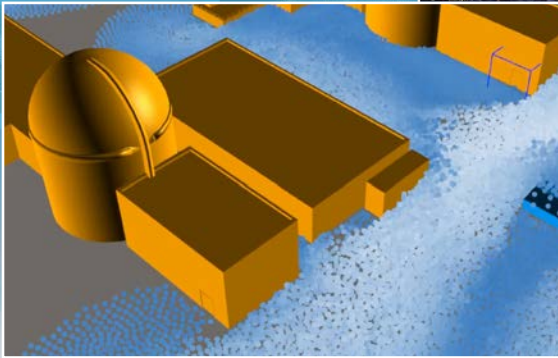
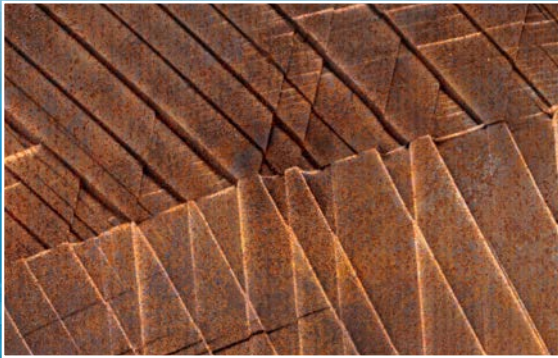


# LWRS



LIGHT WATER REACTOR  
SUSTAINABILITY

# 2019 Accomplishments Report



U. S. DEPARTMENT OF  
**ENERGY**

## From the LWRs Program Technical Integration Office Director



**Bruce Hallbert, Director, LWRs Program Technical Integration Office.**

Nuclear energy is an important part of supplying our nation's energy—safely, dependably, and economically—with reduced carbon dioxide emissions. The United States (U.S.) Department of Energy-Office of Nuclear Energy (DOE-NE) supports a strong and viable domestic nuclear industry. In collaboration with industry programs, the Light Water Reactor Sustainability (LWRs) Program supports the continued operation of the commercial fleet of nuclear power plants. DOE's role in this program focuses on enhancing the safe, efficient, and economical performance of the nation's nuclear fleet. This report describes the accomplishments of the LWRs Program during Fiscal Year 2019.

For the LWRs Program, sustainability is defined as the ability to maintain safe and economic operation of the existing fleet of nuclear power plants for as long as possible and practical. It has two facets with respect to long-term operations: (1) to provide science-based solutions that enable industry to exceed the performance of the current labor-intensive business-model and (2) to manage the aging of plant systems, structures, and components (SSCs) so that nuclear power plant lifetimes can be extended and plants continue to operate safely, efficiently, and economically. The LWRs Program achieves its mission by conducting research and development (R&D) in five complementary areas described below:

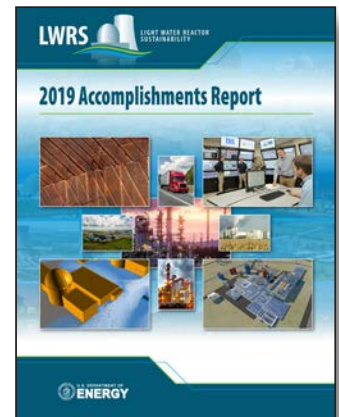
- **Plant Modernization:** R&D to address nuclear-plant economic viability in current and future energy markets through innovation, efficiency gains, and business-model transformation using digital technologies. This includes addressing long-term aging and modernization or replacement of legacy instrumentation and control (I&C) technologies by research, development, and testing of new I&C technologies and advanced condition-monitoring technologies for more-automated and reliable plant operation. The resulting R&D products will enable nuclear power plant owner-operators, vendors, and suppliers to modernize plant systems and processes and transition to a technology-centered business-model that achieves improved performance at lower cost.
- **Flexible Plant Operation and Generation:** R&D to identify opportunities and develop methods for light-water reactors (LWRs) to directly supply energy to industrial processes to diversify approaches to revenue generation. This pathway adapts and uses analysis tools developed by DOE to complete technical and economic assessments of large, realistic market opportunities for producing nonelectrical energy products in close proximity to nuclear power plants. Engineering development and design, testing, and demonstration of integrating nuclear power plants with other industrial processes are carried out. Pertinent safety assessments and licensing approaches are addressed to help support LWR owners with the integration of the new processes.

- **Risk-informed Systems Analysis:** R&D to develop and deploy risk-informed tools and methods to achieve high levels of safety and economic efficiencies. The pathway will: (1) develop technologies that enable better representation of safety margins and use them to characterize the factors that contribute to cost and risk and (2) conduct advanced risk-assessment applications with industry to enable more cost-effective plant operation. The tools and methods provided by the pathway will support effective safety-margin management for both active and passive SSCs of nuclear power plants.
- **Materials Research:** R&D to develop the scientific basis for understanding long-term environmental degradation and predicting the performance of materials in nuclear power plants. This work will provide data and methods to assess the performance of SSCs essential to safe and sustained nuclear power plant operations. R&D products will be used to inform operational limits and aging-mitigation approaches for materials in nuclear power plant SSCs that are subject to long-term operating conditions, providing key input to both regulators and industry. The intent is to help reduce operating costs, This may be accomplished by offsetting maintenance costs using better predictive models for component lifetime, improved analysis of materials through non-destructive evaluation, reduced costs for repairs, or extended performance of plants through the selection of improved replacement materials.
- **Physical Security:** R&D to develop methods, tools, and technologies to optimize and modernize a nuclear facility’s security posture. The pathway will: (1) conduct research on risk-informed techniques for physical security that account for a dynamic adversary; (2) apply advanced modeling and simulation tools to better inform physical-security scenarios and reduce uncertainties in force-on-force modeling; (3) assess benefits from proposed enhancements and novel mitigation strategies and explore changes to best practices, guides, or regulation to enable modernization; and (4) enhance and provide the technical basis for stakeholders to employ new security methods, tools, and technologies.

The accomplishments of R&D activities in this report summarize how the LWRS Program and collaborating organizations achieve or enable progress in key areas needed for the continued operation of nuclear power plants. These results and accomplishments directly support the mission of the LWRS Program, which is to develop the scientific basis and science-based methodologies and tools for the safe and economical long-term operation of the nation’s high-performing fleet of commercial nuclear power plants.

## Contents

<b>2019 Research Highlights</b> .....	4
Plant Modernization .....	4
Flexible Plant Operation and Generation .....	21
Risk-informed Systems Analysis .....	32
Materials Research .....	41
Physical Security .....	52
<b>Program Contacts</b> .....	62



### On the Cover

*This year’s cover features the five LWRS Program Pathways. The four outer graphics (clockwise, starting with the upper left) represent Materials Research, Plant Modernization, Physical Security, and Risk-Informed Systems Analysis. The center arrangement represents Flexible Plant Operation and Generation.*

## 2019 RESEARCH HIGHLIGHTS

### Plant Modernization

**P**lant Modernization Pathway research aims to reduce the technical, financial, and regulatory risks of plant modernization while ensuring the safe, reliable, long-term performance of operating nuclear power plants. It includes collaborations with nuclear utilities and suppliers to accomplish research activities and ensure a direct tie to implementation and commercial deployment. These research accomplishments demonstrate and validate new technologies and concepts that provide the U.S. nuclear industry guidance for full-scale implementation.

Light Water Reactor Sustainability (LWRS) Program research activities address the urgent need to modernize the U.S. nuclear fleet focusing on three areas:

1. Modernizing instrumentation and control (I&C) architecture
2. Automating plant processes through enhanced digital architectures
3. Innovating advanced applications that improve work efficiencies.

LWRS Program research provides results that can be used to enable significant improvements in operational efficiencies through their deployment. The resulting transformational concepts and technologies enable transition from labor-centered to technology-centered plant operations to significantly reduce the operating costs of the U.S. light water reactor (LWR) fleet.

The following sections summarize research and development (R&D) accomplishments in plant modernization that illustrate how the goals of the program are being achieved.

#### Modernizing I&C Architecture

Current instrumentation and human-machine interfaces in nuclear power plants employ significant analog technologies. In other power-generation sectors, analog technologies have largely been replaced with digital technologies. Although considered obsolete by other industries, analog I&C continue to function reliably although spare and replacement parts are becoming scarce, increasingly expensive, and less familiar to a newer workforce that is charged to maintain it. I&C system obsolescence impacts the nuclear industry's ability to remain competitive due to these issues.

To address these issues, I&C systems must be modernized with digital technology to be sustainable through subsequent license renewals. LWRS Program researchers are developing strategies and providing the technical bases and cost justifications that support I&C system modernization. Research results provide guidance to the U.S. nuclear industry on how to transition from current analog systems to advanced digital I&C. These I&C system modifications enable significant operations and maintenance (O&M) cost reductions while improving human-system and overall plant performance. Current plant I&C system architectures are transformed by:

1. Transitioning current analog safety-related I&C functions to a single digital safety-related platform

2. Transitioning current non-safety, balance-of-plant I&C functions to a single digital non-safety-related platform
3. Implementing a fully digital main control room where operators can efficiently monitor and control these systems.

I&C system-modernization research is being piloted in projects through full nuclear plant modernization, I&C architecture modernization, and control room modernization projects, described below.

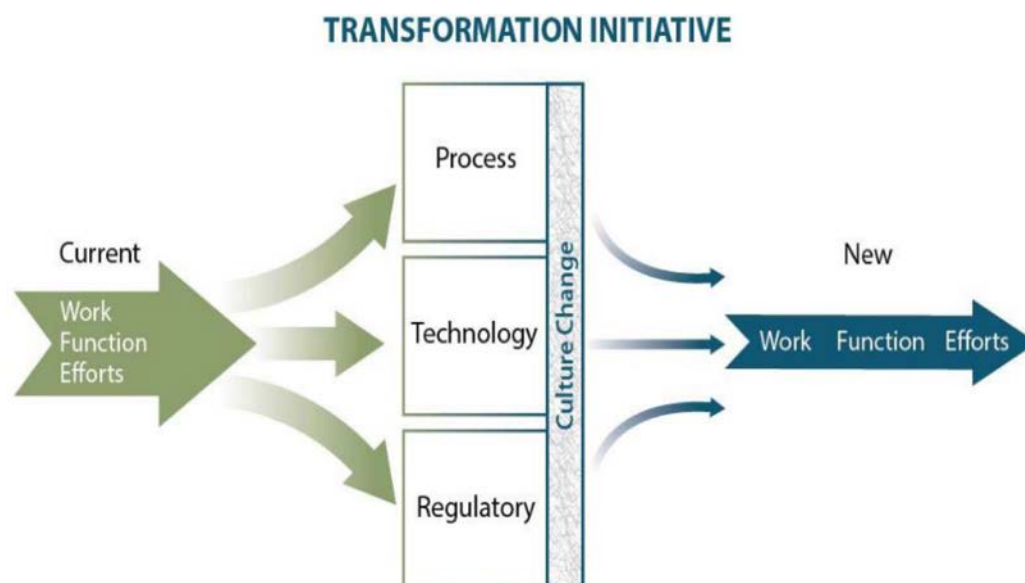
### Full Nuclear Plant Modernization

The Full Nuclear Plant Modernization project provides analysis and applies a planning framework to identify and implement transformative concepts to nuclear plant activities. This includes demonstrating the feasibility and assessing the benefits of full nuclear plant modernization to commercial nuclear operators, suppliers, and the industry-support community.

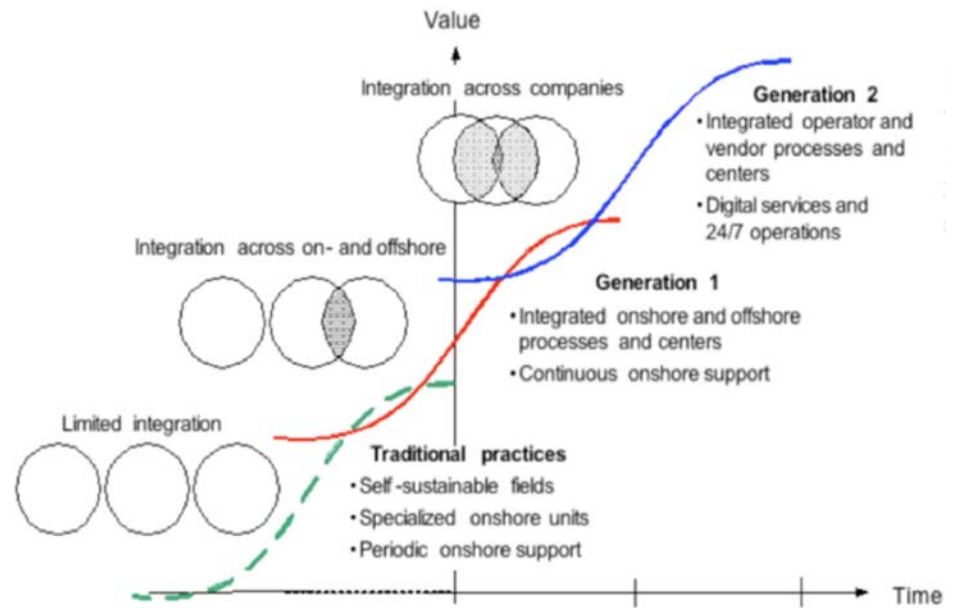
To achieve this goal, LWRs Program researchers developed an operating model-transformation methodology that is used to guide full nuclear plant modernization [1]. This methodology is used to evaluate the current operating model based on its constituent processes, technologies, and regulatory drivers. Working with an owner-operator, researchers use the method to study operational processes and identify where efficiencies and cost-savings could be realized. This process enables the utility to evaluate its present state, establish goals for future O&M costs, and develop transformative pathways to achieve these improvements. An overview of this approach is depicted in Figure 1.

As an example, a collaborating utility estimated the costs of an existing work process for a particular field activity to be \$23,000—taking 16 weeks to plan and perform and involving 11 departments and 41 touchpoints. Using the method, the transformed

**Figure 1. Work Function Analysis.**



**Figure 2. Improved Efficiencies Using Integrate Operations.**

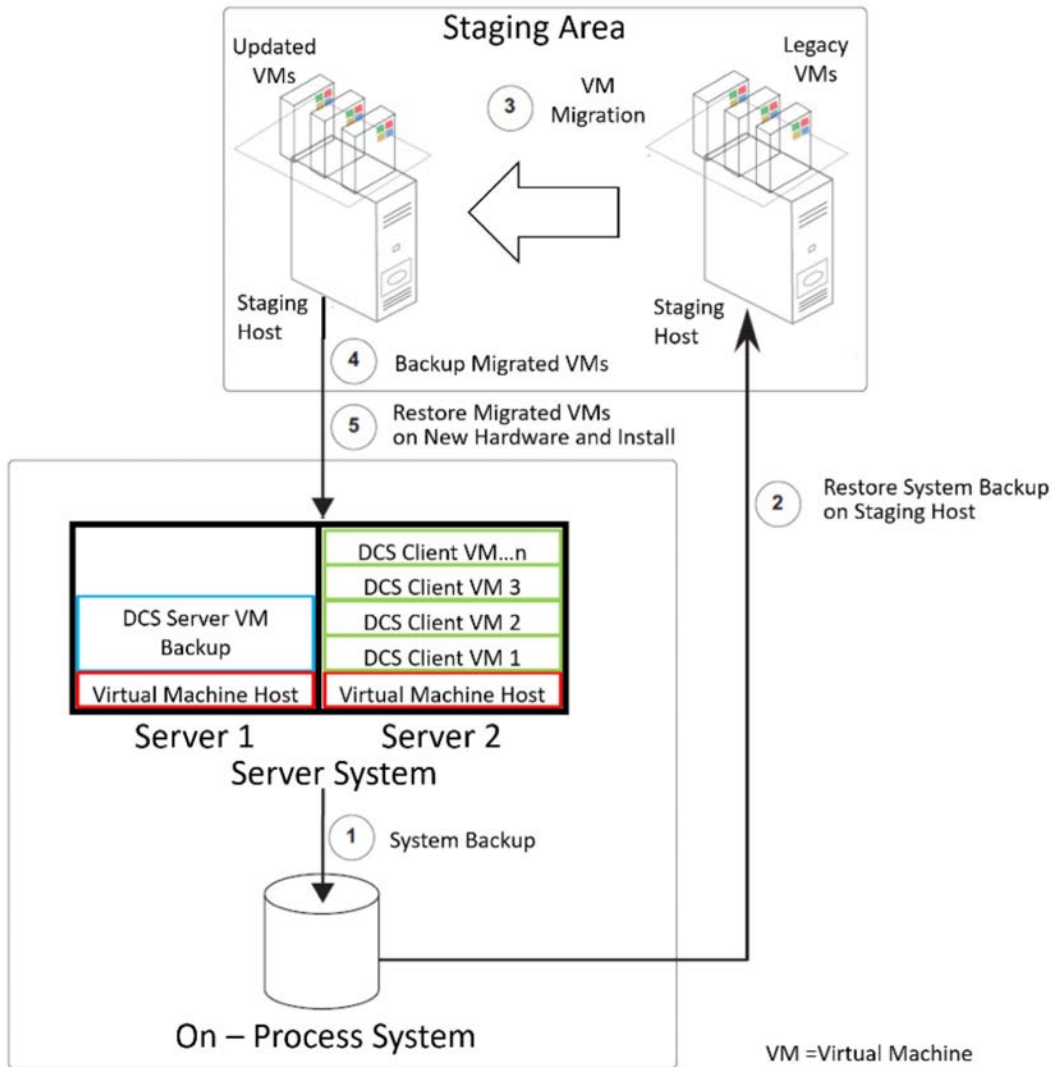


activity was estimated to cost \$6,300, take only 2 weeks to plan and perform, and involve 2 departments and 10 touchpoints.

The underlying concept that enables these improvements is known as integrated operations (IO). This refers to the integration of people, disciplines, organizations, and work processes supported by information and communication technology to conduct technology-enabled work. IO was initially developed in Norway for North Sea oil companies to assist in restructuring their operating models to remain profitable amid depleting offshore oil fields and depressed oil prices. The fundamental premise of IO is that efficiencies and cost-savings are realized (i.e., value increases) when operations that have historically been in silos are integrated. This integration of operations and organizations usually occurs over time because it is not always possible to transform all aspects of operations in one step. An example of value increasing over time as operations become more integrated is shown in Figure 2. The white circles representing work functions and activities become more integrated over time, resulting in O&M cost reductions that allowed operating oil-production platforms to become more economically competitive following years of declining profits.

LWRS Program researchers, collaborating with Xcel Energy, are evaluating the use of IO methods for work processes and activities in the nuclear power industry. The research will provide tools and a methodology to analyze nuclear generation work functions and derive more-efficient means of accomplishing required outcomes through work elimination, process improvement, technology application, and other innovations. Through this collaboration, researchers are developing a framework for applying the IO method as the means of transforming the nuclear operating model.

These research efforts support the development of significant improvements through modernization and digital upgrades, as well as establishing cost-benefits analyses for modernization activities.



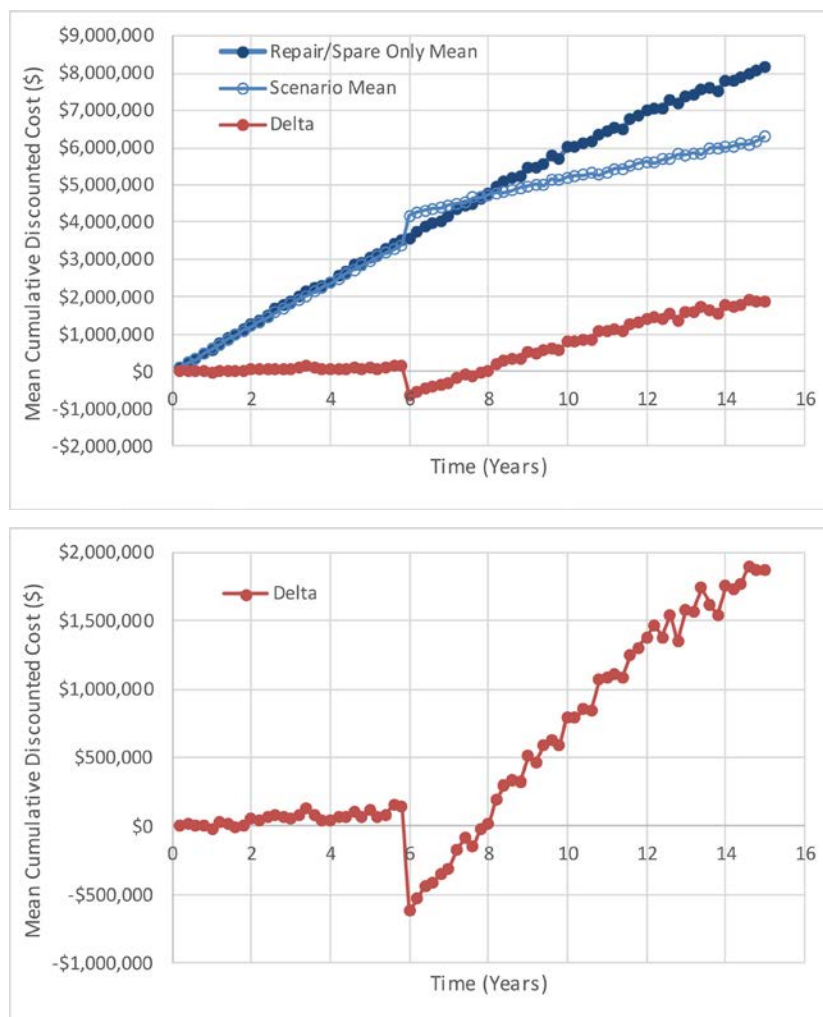
**Figure 3. On-Process DCS Supervisory Network Migration.**

**I&C Architecture Modernization**

I&C architecture modernization research within the LWRS Program aims to provide the nuclear industry specific ways to reduce O&M costs, improve operational performance, and maximize personnel utilization through digitization of plant control systems [2]. The research conducted with collaborators Duke Energy and Honeywell Process Solutions addresses barriers to modernization. It employs advances made by non-nuclear I&C vendors that could be realized through their optimized application in the nuclear power industry. One of the challenges addressed in this research is finding effective techniques to reduce system-outage times during field implementation. These techniques, similar to those presented in Figure 3, represent a method to perform a digital control-system hardware modernization while the facility continues to operate.

In addition to providing best-practice modernization techniques, researchers developed a comprehensive, empirical obsolescence cost model to address long-term obsolescence-management concerns for legacy nuclear power plant I&C systems [3].

**Figure 4. Example obsolescence cost-model results.**



One of the challenges to performing a successful cost-benefit analysis is accurately evaluating the cost of maintaining aging I&C systems. This research provides utilities the tools to quantitatively assess key factors impacting I&C obsolescence cost estimates. The cost models developed by LWRs Program researchers provide the tools necessary for those considering I&C system-architecture modernization to evaluate the replacement costs of a digital system and empirically calculate expected savings for different obsolescence-management scenarios, as shown in Figure 4.

### Control Room Modernization

Control room modernization research provides guidance to enhance control room operations, reduce costs, and improve operator performance. LWRs Program researchers, collaborating with owner-operators in ongoing modernization projects, are using digital I&C to develop an improved control room design that reduces administrative tasks, streamlines work processes, and enhances human performance. The research applies technologies across nuclear power plant workflows to innovate the way work is done in the main control room. The following paragraphs summarize



three research activities in the areas of alarm management, advanced task-based displays, and computerized operator support systems.

Alarm management and procedure use and adherence are key human and technology challenges in existing analog-technology-based main control rooms. They have challenged human performance since the accident at Three Mile Island Unit 2. Legacy technologies necessitate the current number of operators that staff a nuclear power plant control room. In 2019, LWRS Program researchers used machine-learning to develop a state-based alarm system to improve alarm management. The state-based alarm system prioritizes, and filters alarms based on the current plant mode and conditions to make alarm information more relevant and useful and to improve situational awareness among operators. It will also reduce the mental burden of responding to nuisance, redundant, or irrelevant alarms. This novel approach decreases the mental effort needed by operators to use their control room indicators and demonstrates an approach to employing advanced technology in control room modernization projects that allows state-based alarm systems to be developed, tested, and deployed [4].

Researchers also developed and tested advanced task-based displays. These information-rich displays provide integrated information to control room operators that is synthesized from a number of sources to be used for performing specific activities. Using task-based displays, operators are able to access and process the information needed to carry out control room tasks more efficiently. These displays provide task-related information in a single context-sensitive display to achieve improvements in the way information is displayed and used. The development of human-performance data collection and evaluation tools accompanied this research. Several tools were developed that include means to model the results of data collected from human-in-the-loop research with advanced displays and systems studied in the Human Systems Simulation Laboratory (HSSL). Figure 5 shows an example of one of the tools used to enhance modeling, collection, and analyses of



**Figure 5. Human performance measurement tools are used with eye-tracking technology and user testing to conduct evaluations of new digital technologies.**

**Figure 6. Palo Verde operators participate in a control room modernization workshop in the Human Systems Simulation Laboratory at INL.**



eye-tracking data [5, 6]. Use of advanced design and validation techniques improves the quality of end-state requirements developed from human-in-the-loop studies for control-room modernization. [7].

Researchers collaborating with Palo Verde Generating Station evaluated candidate advanced alarms and task-based overview displays with licensed operators during workshops conducted in the HSSL, as shown in Figure 6. The results of these evaluations are documented in Reference 8.

A computerized operator support system (COSS) that is designed to improve system monitoring at nuclear power plants was also studied in this research. Prototypes for the COSS screens were developed for use in a field control station for the boric-acid concentrator and liquid-radwaste system. The prototype screens and COSS functions were evaluated in studies with the Palo Verde operators. This system, developed by LWRS Program researchers, is a software-based system that assists operators with diagnosis, assessment, and response to plant conditions—including plant upsets—using advanced visualizations, and prognostics [9].

### **Automating Plant Processes through Enhanced Digital Architectures**

Automation of manually performed activities will substantially reduce nuclear plant operating costs. As the nuclear industry drives to reduce its total cost of ownership, the need arises for more and better components and types of system-performance monitoring, including automation of these functions. LWRS Program researchers are collaborating with industry to develop these technologies. Research results will enable the LWR fleet to transition from manual periodic assessment of components and systems to automated remote monitoring. The ability to continuously monitor equipment status will have the added benefit of enabling predictive maintenance. Currently, the industry relies heavily on periodic time-based maintenance for active

plant equipment. Industry and LWR Program researchers are developing and demonstrating predictive-maintenance diagnostic and prognostic models that make possible transitioning to highly desired predictive maintenance, substantially reducing operating costs.

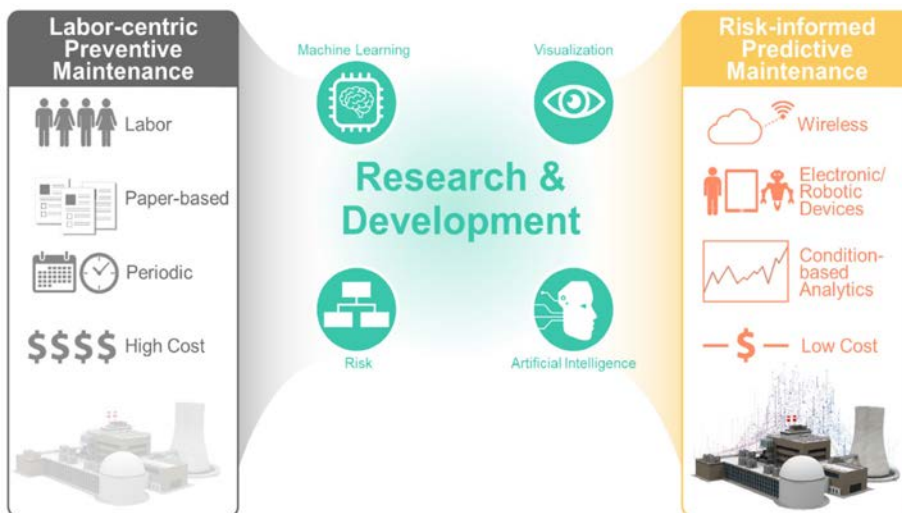
A key to effective application of automation, advanced monitoring and equipment diagnostics, is an enhanced digital architecture. An enhanced digital architecture integrates plant data, including information like system parameters, component configuration, and maintenance instructions. LWR Program researchers are working with industry to develop this architecture. The goal is to provide the industry a proven automation approach, its cost to implement, and the direct cost-savings to deploy these technologies. The three projects described below—TERMS, ARMOR and Digital Architecture for an Automated Plant—are the main research efforts being conducted to develop these solutions.

**Technology Enabled Risk-Informed Predictive Maintenance Strategy**

Technology enabled risk-informed predictive maintenance strategy (TERMS) research integrates advances in online automated asset monitoring and data-analysis techniques with advanced risk assessment methodologies that reduce maintenance costs and enhance the reliability of commercial nuclear power plants.

To achieve high capacity factors, the existing nuclear fleet has relied on labor-intensive and time-consuming preventive maintenance programs to operate and maintain plant systems. This approach contributes to high operating costs. Research is underway to develop and demonstrate a framework to deploy a risk-informed predictive maintenance program, as shown in Figure 7. An advanced integrated risk-informed predictive-analytics framework is being developed that supports automation and optimization of maintenance activities in commercial nuclear power plants.

In collaboration with the Public Service Enterprise Group, Nuclear LLC-owned Salem Nuclear Power Plant and PKMJ Technical Services Inc., LWR Program researchers are developing a technical basis to deploy a risk-informed predictive-maintenance



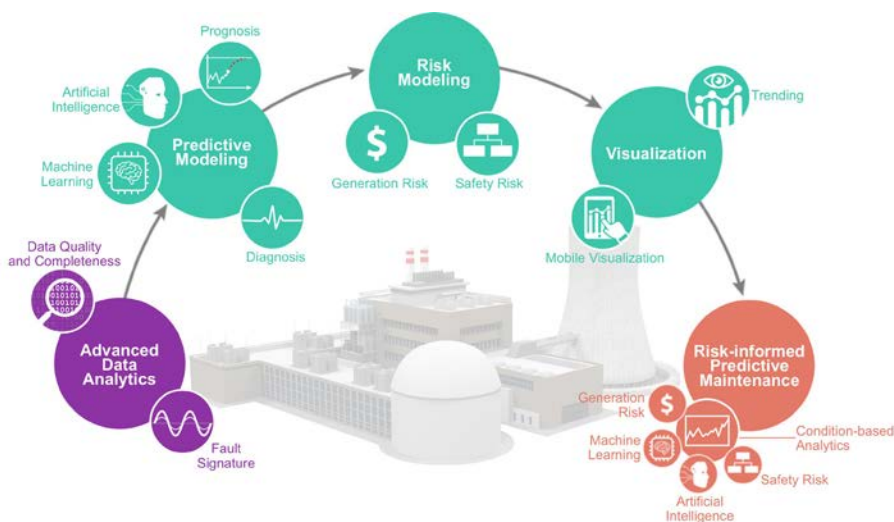
*Figure 7. Transition from a preventive maintenance program to a risk-informed predictive maintenance program.*

strategy. Adoption of the risk-informed predictive maintenance strategy will benefit commercial nuclear power plants by enhancing the reliability of plant systems under different operating conditions, lowering maintenance costs, reducing downtime, and increasing power generation by increasing plant availability.

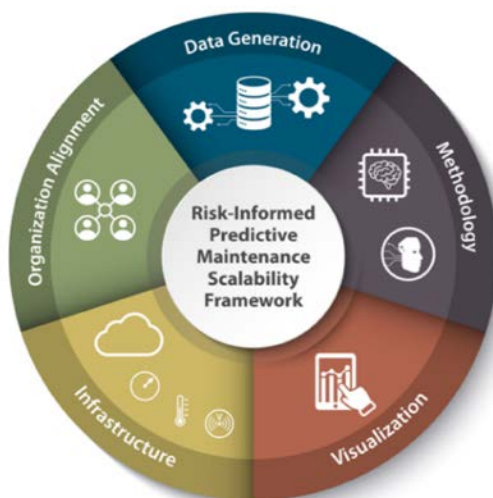
A general schematic of research activities to achieve this risk-informed predictive-maintenance strategy, is shown in Figure 8. This strategy will employ advances in data analytics, predictive modeling, risk modeling, and visualization to achieve these results. Scalability is another component to ensure successful deployment of the strategy. The elements needed to achieve scalability are shown in Figure 9. Scalability across both plant systems and the entire nuclear fleet depend on organizational alignment and agile infrastructure. Properly integrating these elements with data generation, methodology, and visualization are crucial to support a successful and smooth transition.

Plant Modernization Pathway researchers, collaborating with KCF Technologies (a sensor vendor), PKMJ Technical Services, Inc., and Public Services Enterprise Group,

**Figure 8. TERMS key analysis components.**



**Figure 9. TERMS key scalability components.**



Nuclear LLC, through a competitively awarded pilot project, will demonstrate key elements of an effective risk-informed predictive-maintenance strategy. Data quality and completeness is the foundation to enable this strategy. Researchers and pilot partners develop a data-generation and communication approach using cloud-based wireless vibration sensors on an actual plant system. Data generation and quality are the major efforts required by commercial nuclear power plants across the nuclear fleet to enable enhanced online monitoring capabilities. They directly support development and application of an online-monitoring model. Researchers performed an initial review of signals from KCF Technologies wireless sensors and observed them to be consistent with the signals obtained during periodic vibration measurement. [10]

The team also developed a generation-risk model to account for loss of power generation due to unscheduled and scheduled downtime of a plant system. This will enable commercial nuclear power plants to plan maintenance activities to minimize generation losses. The team defined the technical foundation to achieve scalability of the developed predictive-maintenance strategy across plant systems at one plant site, or to scale more broadly across a fleet of nuclear assets, as shown in Figure 9. This effort, along with the necessary cost-benefit analyses in conjunction with industry-led collaborations, enables plant modernization.

### **Advanced Remote Monitoring for Operations Readiness**

The Advanced Remote Monitoring for Operations Readiness (ARMOR) research is developing automation of plant monitoring to gather data and detect process anomalies prior to equipment malfunction. The results of this research will reduce labor-intensive field activities, reducing plant operation costs.

Operations often become a limiting factor in the execution of day-to-day work activities in a plant. With current technological advancements in sensors and data analytics, it is possible to replace a significant portion of operations activities with sensors and a centralized decision-making process. The instruments needed to automate the manual collection of process information by operators often exists elsewhere, in other industrial settings. These solutions can be tailored for use by nuclear power plants. LWRs Program researchers collaborated with a technology developer to create a multisensor measurement solution, shown in Figure 10, that is customized for monitoring standby equipment [11]. This application introduced custom features, such as the ability to automatically start the measurement process when the equipment is in operation (by using equipment vibration to switch on the



**Figure 10. Multi-sensor measurement unit.**

measurement unit) or to start on demand only (i.e., user-triggered data collection). These features enable the customized technology to generate data only when the equipment is running and is meaningful, typically a few hours every few months. This extends the battery life of the devices because they are in sleep mode when the equipment is not running. The unit was tested on a fire-protection pump as part of a pilot.

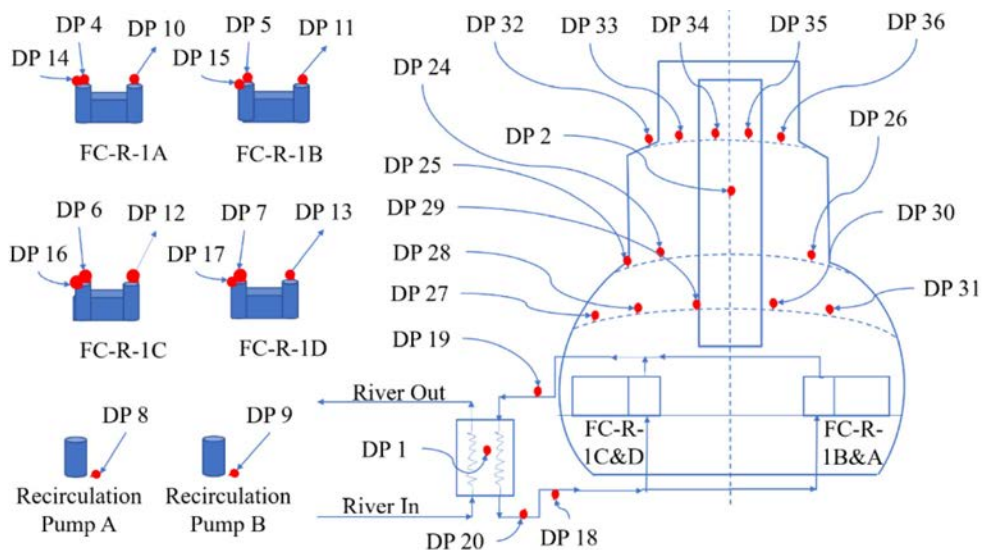
To demonstrate how advanced technologies can support operational decision-making, LWRs Program researchers collaborated with Cooper Nuclear Station through a competitively awarded pilot project to develop machine-learning methods capable of detecting anomalies before they occur. Two Cooper Nuclear Station drywell fan-coil units were the focus of this effort. They had failed in May 2018, resulting in a plant outage for six days. Because the fan-coil units were not equipped with vibration measurement, 36 process data points were used from processes surrounding the fans, as shown in Figure 11.

The result of applying various methods of machine-learning can be found in Ref. [12]. An example of how machine-learning can be used is shown in Figure 12. Using long short-term memory, an artificial recurrent neural network architecture used in the field of deep learning, it was possible to detect deviations and potential failures of the fan-coil units eight days ahead of an actual failure.

### Advanced Remote Monitoring of Secondary System Piping in Nuclear Power Plants

LWRs Program researchers are developing high-spatial-resolution fiber sensors to improve detection of corrosion- and erosion-induced defects in complex piping geometries, such as elbows, tees, and bends. This research will address the technology gap in the area of piping erosion and corrosion, in addition to erosion monitoring by adding new sensor modalities capable of dealing with geometries inaccessible with ultrasonic guided waves and will significantly increase the coverage for online monitoring systems. This research effort will reduce the high costs and inefficiencies

**Figure 11. Process data points used to detect anomalies.**



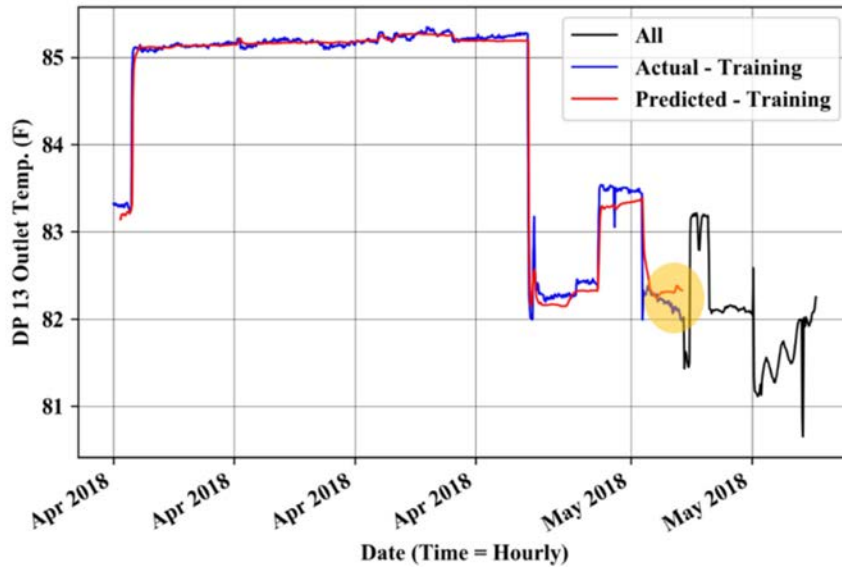


Figure 12. Application of long short-term memory on plant process data and detection of anomaly by divergence.

associated with periodic piping inspections and support a transition from periodic piping inspections to as-needed piping repair.

Additional benefits of this project are analysis and recommendations for science-based methods for structural health monitoring of secondary systems in nuclear power plants, which can be used to enhance materials management and contribute to the sustainability of the existing commercial LWR fleet.

Distributed high-temperature-stable fiber sensors were fabricated in optical fibers through a roll-to-roll direct laser-writing process using femtosecond lasers, as shown in Figure 13. Using phase-sensitive optical time-domain reflectometry, distributed acoustic and vibration sensors will be developed and deployed to critical components and systems in power plants to perform active measurements with spatial resolution down to 0.5-meter throughout the power systems. Complex acoustic and vibration signatures harnessed by distributed fiber sensors will be observed and analyzed by deep-neural-network artificial-intelligence (AI) algorithms for defect detections and abnormal-event identification.

In collaboration with the University of Pittsburgh and EPRI, LWRs Program researchers developed AI-enabled high-spatial-resolution fiber sensors to detect piping

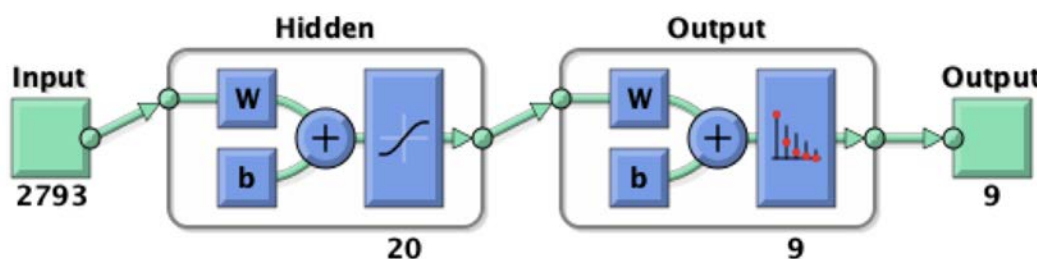


Figure 13. Shallow neural network architecture to perform pattern recognition of fiber optics signals.

degradation, to reduce the influence of both human-performance variability and hardware factors in detecting changes to pipes, and to improve pattern recognitions in secondary piping. Using high-spatial-resolution data gathering from distributed fiber sensors (acoustic, temperature, and strain) and shallow-neural-network machine learning, this research demonstrated that different levels of single-location piping degradation in straight piping and 90-degree elbows can be reliably detected and qualified with high accuracy. The developed technology is unique in that it allows inspection of up to 15 miles of piping from a single location, regardless of piping geometry. This capability is unmatched by other nondestructive examination techniques. Several journal and conference publications are being prepared to disseminate results of this research.

The results of this research provide conclusive recommendations about capabilities of artificial intelligence-enabled high-resolution fiber optics as a tool for online monitoring of integrity and corrosion/erosion degradation of the piping components of LWR nuclear power plants as documented in Ref. [13]. The results included recommended approaches for the continuous assessment of subject plant components and materials in nuclear power plants during long term operation for purposes of decision making and asset management. Ultimately, this research will provide guidance to nuclear power plants on how to migrate to a data-driven condition-monitoring maintenance program to enable plants to realize improvements in efficiency through enhanced monitoring capabilities.

#### Automated Online Monitoring of Concrete Structures in Nuclear Power Plants

The LWRS Program conducts research to enable plant operators to make risk informed decisions on structural integrity, remaining useful life, and performance of concrete structures across the nuclear power plant fleet. To achieve this goal, the Plant Modernization Pathway collaborates with Vanderbilt University, the University of Alabama—Tuscaloosa, the University of Nebraska—Lincoln, and Oak Ridge National Laboratory to investigate a probabilistic framework for structural health monitoring and managing the condition of aging concrete structures in nuclear power plants. This integrated framework includes four elements: (1) monitoring, (2) data analytics, (3) uncertainty quantification, and (4) prognosis.

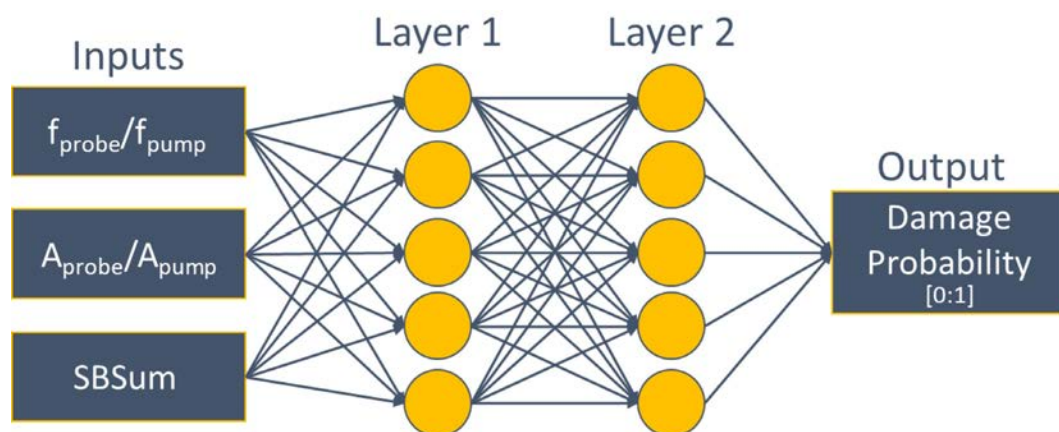


Figure 14. Artificial neural-network structure.



Research outcomes published in Ref. [14] provide details on the application of a vibro-acoustic modulation (VAM) technique to obtain degradation data on multiple concrete structures from a series of experiments conducted under controlled laboratory conditions. The degradation mode investigated was alkali silica reaction in concrete samples differing in size and types of embedded aggregates. The report focuses on damage localization using the VAM technique and investigates the effect of different characteristics of dual-frequency vibration tests on damage-localization results. Results for damage localization are dependent on multiple parameters used in the tests, including excitation frequencies, amplitudes, and locations. Construction of a data-driven machine-learning model was investigated to localize the damage as a function of the test parameters, using data from VAM.

An artificial neural-network model, shown in Figure 14, is created using data from multiple specimens to achieve accurate estimation of damage probability in any type of sample. The training data are from specimens having different compositions and geometries. The input data include ratio of probing and pumping frequencies ( $f_{\text{probe}}/f_{\text{pump}}$ ), ratio of probing and pumping amplitude ( $A_{\text{probe}}/A_{\text{pump}}$ ), and the sum of sidebands (SBSum). Sidebands are frequency components of a probing frequency that helps determine if there is degradation. In Figure 15, the dashed circles represent the locations where reactive aggregates were placed. The initial machine learning results show a promising outcome with a high percentage of damage localization, also shown in Figure 15 through the color maps, where 0 indicates no damage and 1 indicates damage.

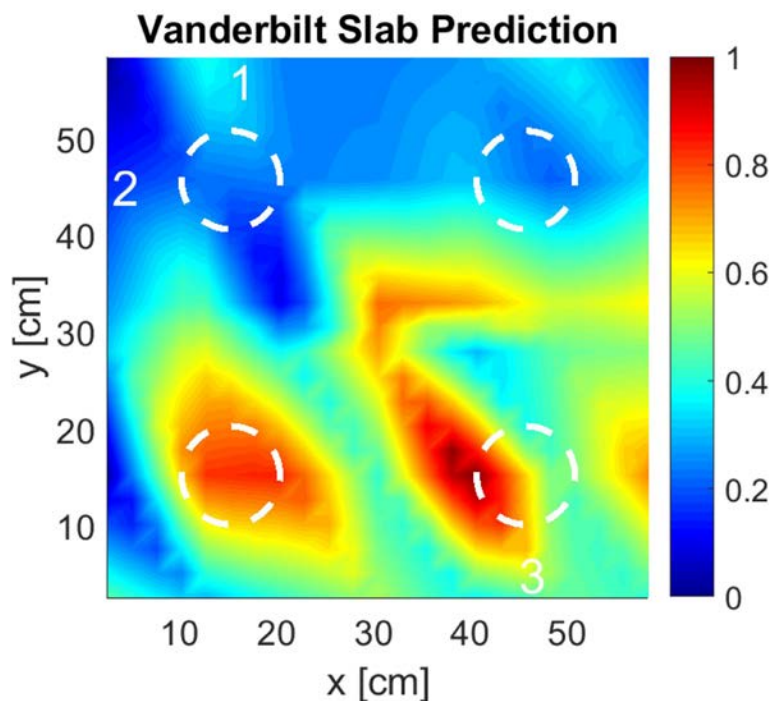
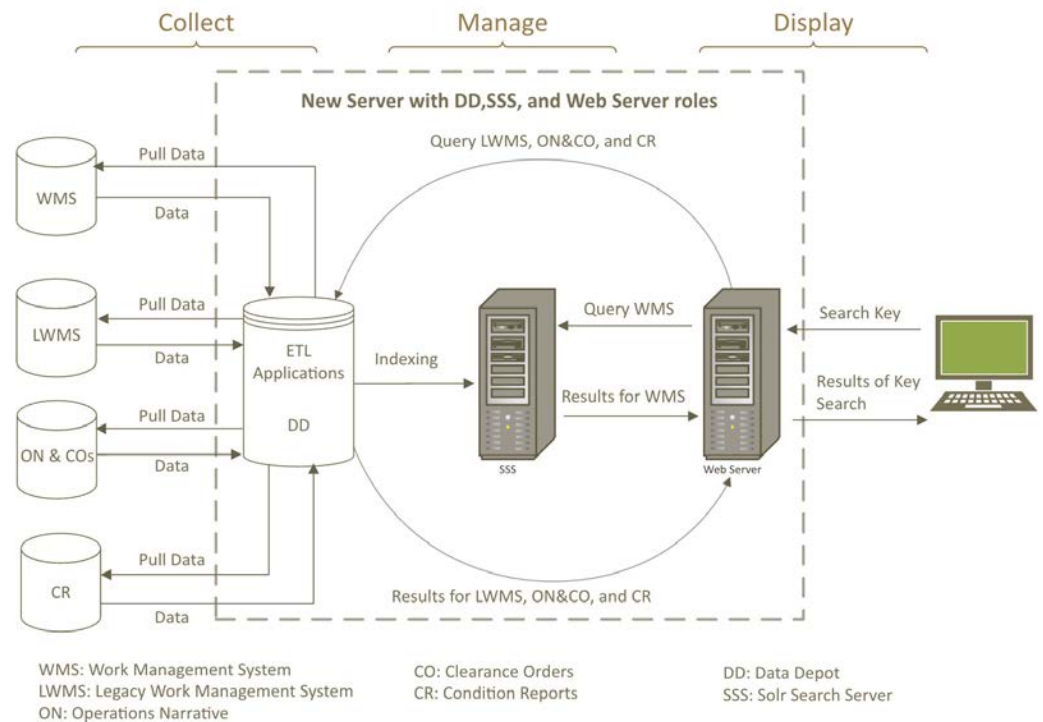


Figure 15. Neural-network estimation of damage.

**Figure 16. Digital architecture created to integrate data at a nuclear power plant.**



As part of future research on enhancing the machine-learning model, a combination of physics-based modeling of degradation with experimental data will be performed to achieve prognosis and uncertainty quantifications of future damage evolution.

This research will develop an enhanced structural-health monitoring framework using advanced data analytics and machine-learning techniques to augment or replace manual inspection with online monitoring (reducing maintenance costs).

### Digital Architecture for an Automated Plant

Efficiently managing information from different tools and systems within nuclear power plants is key to deploying technologies and solutions described in many other areas of ongoing research projects. It is vital to improving work practices in the nuclear industry, developing digitally based mobile technologies for workers, supplying information needed for advanced interfaces and displays in the main control room, and using technologies in online monitoring of plant equipment. It is also needed to achieve the levels of automation that will reduce labor-intensive and expensive work practices at plants today. There are certainly effective products available for certain processes, but no common or integrated architecture is available for managing digital information. This creates a challenge to effectively modernize the way data is managed because approaches to information management may be proprietary or developed for individual projects without a longer-term strategy. To help the nuclear industry overcome these challenges LWRS Program researchers are developing a digital-data repository architecture that will enable nuclear power plants to effectively collect,

store, and use data. A participating utility in this research has estimated that almost 50% of its operating costs are associated with compliance activities, such as nuclear regulatory, environmental, and personnel safety compliance. These activities involve mostly manual processing of plant and program information to generate data. Digital architecture research will support automating the verification of compliance status directly from data of the associated processes with less human effort, thereby reducing operating costs.

Initial efforts focus on improving data integration. Most plant data systems have been developed independently for individual purposes. They store information using different coding approaches that are unique to the code. The integration of data sources via an enhanced digital-data repository architecture, as shown in Figure 16, can reduce direct and indirect costs by automating data collection and analysis currently performed manually. Using this digital-data repository architecture, methods developed to use data gathered in a single plant to automate an activity (e.g., conditions reports screening) can be applied to another plant that has different data sets with minimal effort.

This architecture leverages existing industrial standards and integrates digital information needed for automation of nuclear industry [15]. To develop the enhanced digital architecture and evaluate its potential for use, a study was carried out with participation of the Cooper Nuclear Power Station. This project integrated four disparate data sets, as shown in Figure 16 [16]. The project provided researchers and nuclear-industry collaborators insights into the various activities involved in developing the architecture and identified the core data objects needed to achieve desired levels of plant automation.

## References

1. J. C. Joe and S. J. Remer, 2019, "Developing a Roadmap for Total Nuclear Plant Transformation," INL/EXT 19 54766, Idaho National Laboratory, Idaho Falls, ID, USA.
2. P. J. Hunton and R. T. England, 2019, "Addressing Nuclear I&C Modernization through Application of Techniques Employed in Other Industries," INL/EXT 19 55799, Idaho National Laboratory, Idaho Falls, ID, USA.
3. M. D. Muhlheim, P. J. Hunton, P. A. Sandborn, E. L. Quinn, R. E. Hale, and R. T. England, 2019, "Development of an Obsolescence Cost Model for Nuclear Power Plants," ORNL/TM 2019/1238, Oak Ridge National Laboratory, Oak Ridge, TN, USA.
4. J.-P. Langstrand, H. Nguyen, and R. McDonald, 2019, "Report for 2.2.1, Task 5: Develop and Document a State-Based Alarm System for a Nuclear Power Plant Control Room using Machine Learning," INL/EXT 19 55368, Idaho National Laboratory, Idaho Falls, ID, USA.
5. R. McDonald and A. O. Braseth, 2019, "Report for 2.2.1 Task 3: Develop and Document an Advanced Human System Interface for the Generic Pressurized Water Reactor Simulator," INL/EXT 19 55789, Idaho National Laboratory, Idaho Falls, ID, USA.
6. M. Hildebrandt, J.-P. Langstrand, and H. Nguyen, 2019, "Report for 2.2.1, Task 4: Software-Based Tools to Support Human-System Evaluation Studies," INL/EXT 19 55789, Idaho National Laboratory, Idaho Falls, ID, USA.

7. K. E. Thomas, J. P. Lehmer, Z. A. Spielman, J. D. Mohon, R. A. Hill, C. R. Kovesdi, and K. L. Le Blanc, 2019, "End State Requirements for Advanced Task-Based Overview and Advanced Alarms," INL/LTD 19 54456, Idaho National Laboratory, Idaho Falls, ID, USA.
8. C. R. Kovesdi, J. D. Mohon, K. Herdt, Z. A. Spielman, R. A. Hill, J. P. Lehmer, and K. L. Le Blanc, 2019, "Evaluation of Advanced Task-Based Overview Displays and Alarms," INL/LTD 19 55766, Idaho National Laboratory, Idaho Falls, ID, USA.
9. R. Lew, T. A. Ulrich, T. J. Mortensen, and R. L. Boring, 2019, "Integration of Advanced Operator Interfaces for the Computerized Operator Support System: Example Design Study for the Palo Verde Boric Acid Concentrator," INL/LTD 19 55430, Idaho National Laboratory, Idaho Falls, ID, USA.
10. V. Agarwal, K. A. Manjunatha, J. A. Smith, V. Yadav, M. Archer, N. Gross, M. Mackay, F. Lukaczyk, P. Harry, and M. Pennington, 2019, "Deployable Predictive Maintenance Strategy Based on Models Developed to Monitor Circulating Water System at the Salem Nuclear Power Plant," INL/LTD 19 55637, Idaho National Laboratory, Idaho Falls, ID, USA.
11. A. Y. Al Rashdan and S. W. St Germain, 2019, "Automating Surveillance Activities in a Nuclear Power Plant," INL/EXT 19-55620, Idaho National Laboratory, Idaho Falls, ID, USA.
12. A. Y. Al Rashdan, M. Griffel, R. Boza, and D. P. Guillen, 2019, "Subtle Process Anomalies Detection Using Machine Learning Methods," INL/EXT 19 55629, Idaho National Laboratory, Idaho Falls, ID, USA.
13. A. V. Gribok, Q. Wan, J. Jiang, M. Wang, J. Wu, Z. Mao, and K. P. Chen, 2019, "Structural Health Monitoring of Piping Components in NPPs using High-Spatial-Resolution Fiber And Machine-Learning-Enabled Guided Waves Approach," INL/EXT 19 55800, Idaho National Laboratory, Idaho Falls, ID, USA.
14. V. Agarwal, S. Miele, S. Mahadevan, P. Karve, E. Giannini, and J. Zhu, 2019, "Concrete Structure Health Monitoring Based on Vibro-Acoustic Testing and Machine Learning Approach," INL/EXT 19 55701, Idaho National Laboratory, Idaho Falls, ID, USA.
15. A. Y. Al Rashdan, J. M. Browning, and C. S. Ritter, 2019, "Data Integration Aggregated Model and Ontology for Nuclear Deployment (DIAMOND): Preliminary Model and Ontology," INL/EXT 19 55610, Idaho National Laboratory, Idaho Falls, ID, USA.
16. A. Y. Al Rashdan, C. J. Krome, S. W. St. Germain, and J. Rosenlof, "Method and Application of Data Integration at a Nuclear Power Plant," INL/EXT 19 54294, Idaho National Laboratory, Idaho Falls, ID, USA.

## Flexible Plant Operation and Generation

Flexible plant operation and generation (FPOG) is required to supply energy to an industrial process. FPOG operations provide an offtake opportunity—that is, an agreement to purchase a future product—for energy produced by a LWR power-generating station when the price offered for committing electricity to the grid is lower than the cost of producing this electricity. In one model of FPOG operations, a secondary user may benefit by purchasing electrical power, steam, or thermal energy directly from the LWR site at a cost that is lower than can be purchased from the grid either at times when the electricity grid becomes congested or for other economic reasons. At a minimum, this requires a tightly coupled connection to the power-generation operations of the nuclear power plant. The hybrid operation of a LWR plant may then apportion energy between the industrial user and the electricity grid to optimize the revenue of the nuclear power plant, depending on specific commitments, such as day-ahead electricity-grid capacity commitments and reserve-capacity agreement requirements.

In 2019, the FPOG Pathway applied process-modeling and systems-optimization tools to evaluate the technical feasibility and economic benefits of FPOG. The early evaluations verified that, on a holistic level, flexible nuclear power plant operations could increase the revenue of those plants. FPOG operations can also help stabilize the grid in regions where the percentage of nondispatchable, variable solar- and wind-power generation is becoming significant. This provided incentive to expand the scope of the FPOG Pathway to support R&D that are needed to enable LWR plants to dispatch both thermal and electrical energy to industrial users while holding the reactor core at constant power near the nameplate capacity of the plant.

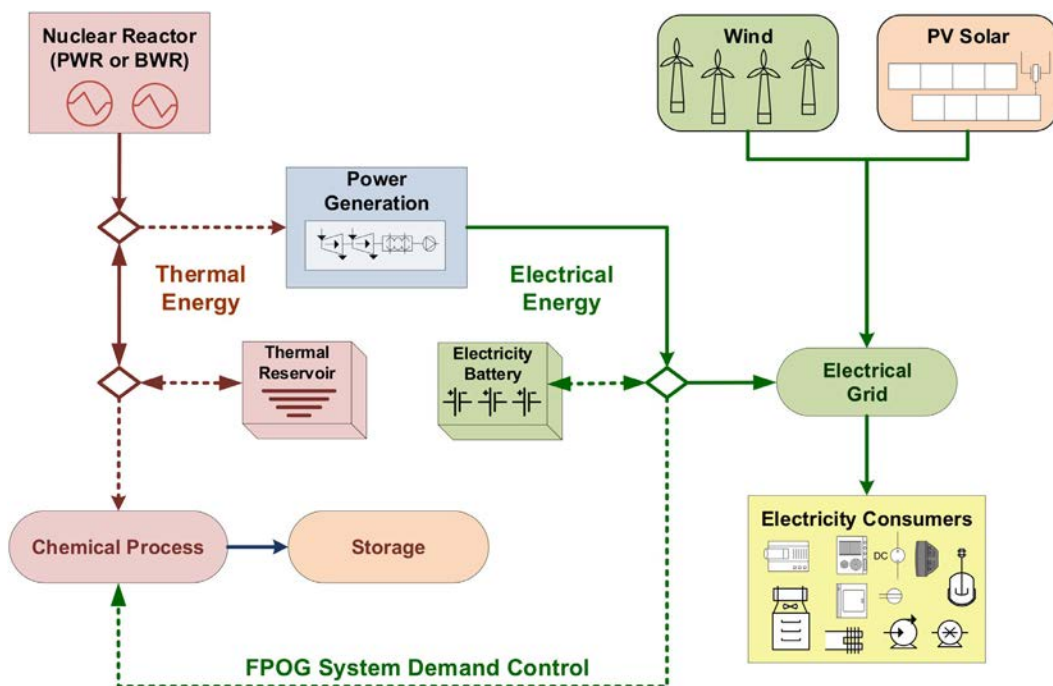


Figure 17. General layout for FPOG.

The FPOG Pathway conducts research in three areas to accelerate the development and demonstration of flexible LWR operations: (1) evaluation of market opportunities; (2) design and demonstration of nuclear energy direct integration with industry; and (3) evaluation of safety hazards and licensing considerations of different technology options.

Figure 17 illustrates the concept of dispatching power to the grid or sending steam and electricity to an industrial user. In this manner, the LWR can also produce nonelectric products during periods of excess power-generation capacity.

Select R&D highlights are provided here. Detailed reports covering the accomplishments can be found on the LWRS Program website (<https://lwrs.inl.gov>).

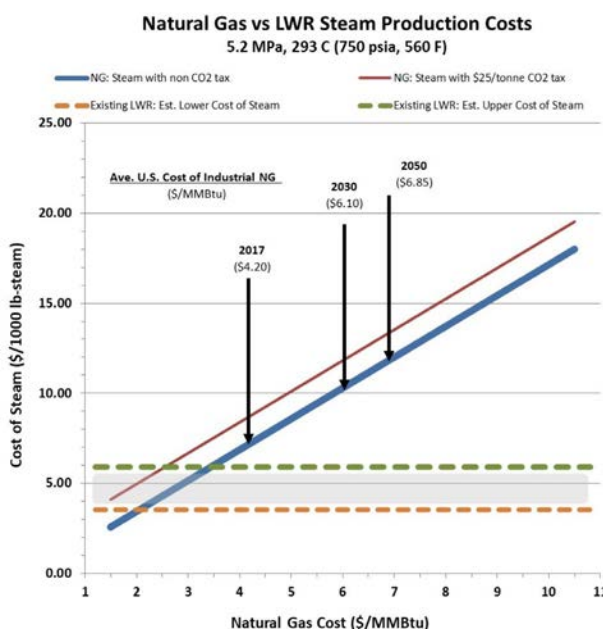
### Evaluation of FPOG Market Opportunities

The FPOG Pathway addresses the technical feasibility and economic viability of LWR FPOG by researching and evaluating realistic markets near specific reactor sites where industry is concentrated and could benefit from direct use of nuclear energy. In 2019, the LWRS Program began conducting technical and economic assessments aimed at understanding the technical feasibility and business case for LWRs directly supplying energy to industrial users. The initial objective was to understand whether LWRs can competitively produce hydrogen and other feedstock commodities, such as polyethylene and formic acid.

### Technical and Economic Assessments

LWRS Program research projected that the cost of producing high-pressure steam for industrial use would be \$4.00–5.25/1000 lb, depending on LWR reactor type and operating costs, as observed in Figure 18. This is 15–45% lower than the cost of

**Figure 18. Cost of high-pressure steam production using natural gas and nuclear energy. Arrows indicate U.S. Energy Information Agency cost projections for natural gas.**



producing steam using a natural gas package boiler even before any credit for CO<sub>2</sub> emissions reduction are applied.

Because there is increasing demand for low carbon-emission products, hydrogen is being considered as a product because it is a clean fuel and is becoming important as it is used in a wide variety of materials manufacturing and chemicals production, and can be used for trucks and cars powered with hydrogen-powered fuel cells. The FPOG Pathway completed a detailed preliminary design and evaluation of coupling either a low-temperature electrolysis plant or a high-temperature steam electrolysis plant (HTSE) to a nuclear plant. The study identified two business opportunities for LWR-supported electrolysis. One case is for smaller plants that would produce hydrogen for fuel-cell vehicle filling stations where low temperature electrolysis plants can be competitive with natural gas steam reforming plants. The second case is for industrial plants that use a large amount of hydrogen where steam electrolysis was shown to be competitive with large-scale natural gas steam reforming plants. The study assumed that hydrogen produced near a nuclear power plant would be compressed and put into a pipeline to be transported to users up to 15 miles from the production source.

Figure 19 presents hydrogen production costs for a large-scale, 500 tonne per day plant based on natural gas reforming versus steam electrolysis when the price of electrolysis units has been reduced by high-volume manufacturing. The study found that hydrogen can be produced for around \$1.50 per kilogram with either a new natural gas reforming plant (represented by the blue bars) or by a steam electrolysis plant that is tied to a nuclear plant (represented by the orange bars). This price includes a price offset with oxygen sales, which are possible with the first electrolysis plants built in a specific region. Other offsets may include capacity payments to the nuclear plant for sending electricity to the grid during periods when electricity demand is relatively high. A \$25 credit for each tonne of CO<sub>2</sub> avoided relative to natural

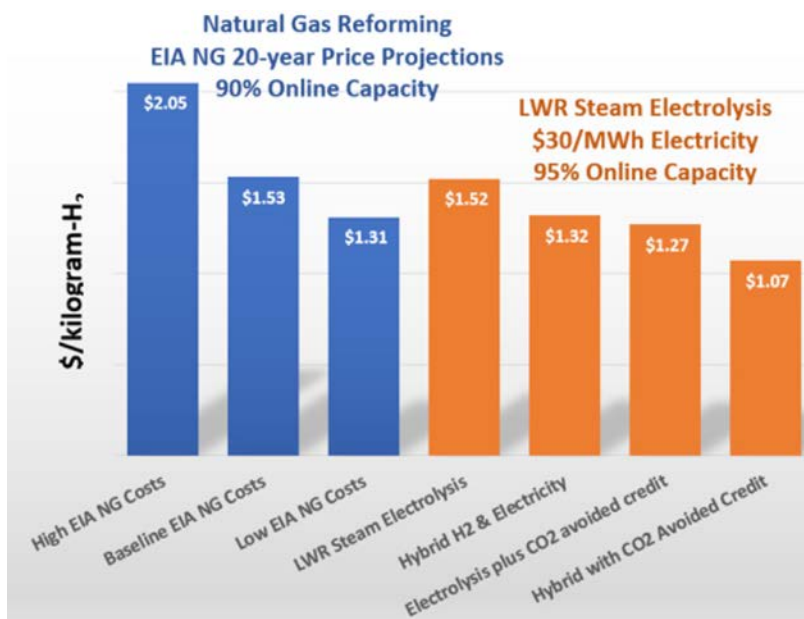
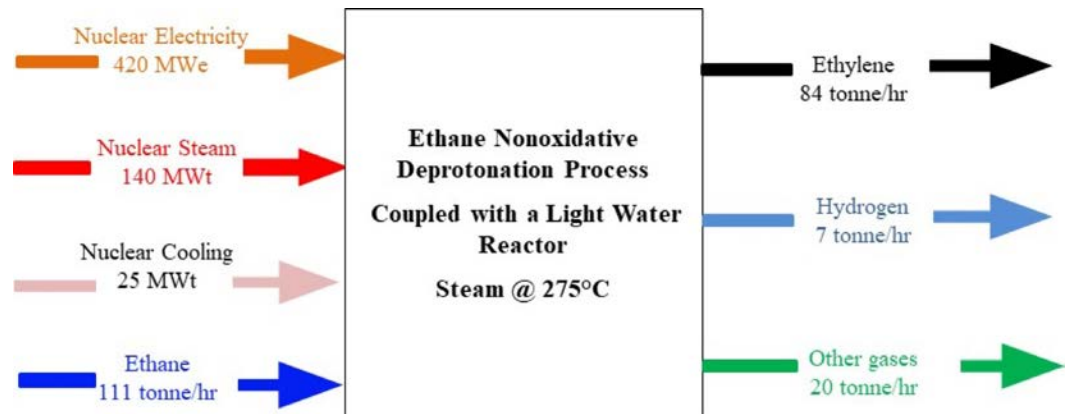


Figure 19. Cost of hydrogen production and delivery for a 500 tonne per day HTSE.

**Figure 20. Overall energy and product flows for the LWR/electrochemical non-oxidative deprotonation process integration case (e.g., electricity, steam, and cooling water are purchased from a nuclear power plant).**



gas reforming could further reduce the cost of hydrogen produced by electrolysis by \$0.25 per kilogram. For the grid conditions used for this evaluation, a hybrid plant sending electricity to the grid just less than 2% of the year with a realistic capacity payment could independently reduce the price of hydrogen by \$0.20 per kilogram. The combined benefits could reduce the cost of the hydrogen produced by the nuclear power plant to around \$1.07 per kilogram.

A preliminary LWR FPOG market outlook identified six major sources of current and future hydrogen demand in the U.S.—ammonia production, oil refineries, synthetic fuels and chemicals, direct reduction of iron, fuel-cell electric vehicles, and the blending of hydrogen with natural gas. Recent market projections by Department of Energy (DOE) and private organizations shows that there is strong potential for new hydrogen markets: [Hydrogen: The next wave for electric vehicles?](#) Many of these opportunities are located within an acceptable distance from nuclear power plants, minimizing new infrastructure demands. Where infrastructure additions are needed, future case-specific analyses will be conducted to consider hydrogen storage, transportation, and delivery to end customers.

The FPOG Pathway assessments also found that a new ethylene production process—the ethane non-oxidative deprotonation process (ENDP)—can reduce the cost of polyethylene production by over 30% when using electricity and thermal energy from a nuclear plant, as shown in Figure 20. This process would exploit the abundant volume of natural gas condensates (ethane and propane) to produce polymers for a growing market. The study projected a net present value of \$285 million with a discounted payback period after five years of operation is possible at the present market selling price of ethylene. When the net present value is set equal to zero at an internal rate of return of 12%, the production cost of ethylene is \$0.37/kg. A conventional steam-cracking plant produced ethylene for about \$0.71/kg. The LWR-supported products would reduce CO<sub>2</sub> emissions by 95% to produce this commodity, compared to conventional methods in use today.

The LWRS Program also completed an independent evaluation of the production of fertilizers, steel, and synthetic fuels using hydrogen produced by LWRs and CO<sub>2</sub> that can be sourced from ethanol plants in the Upper Midwest near the nuclear power plants. The demand for hydrogen by petroleum refineries is another near-term market



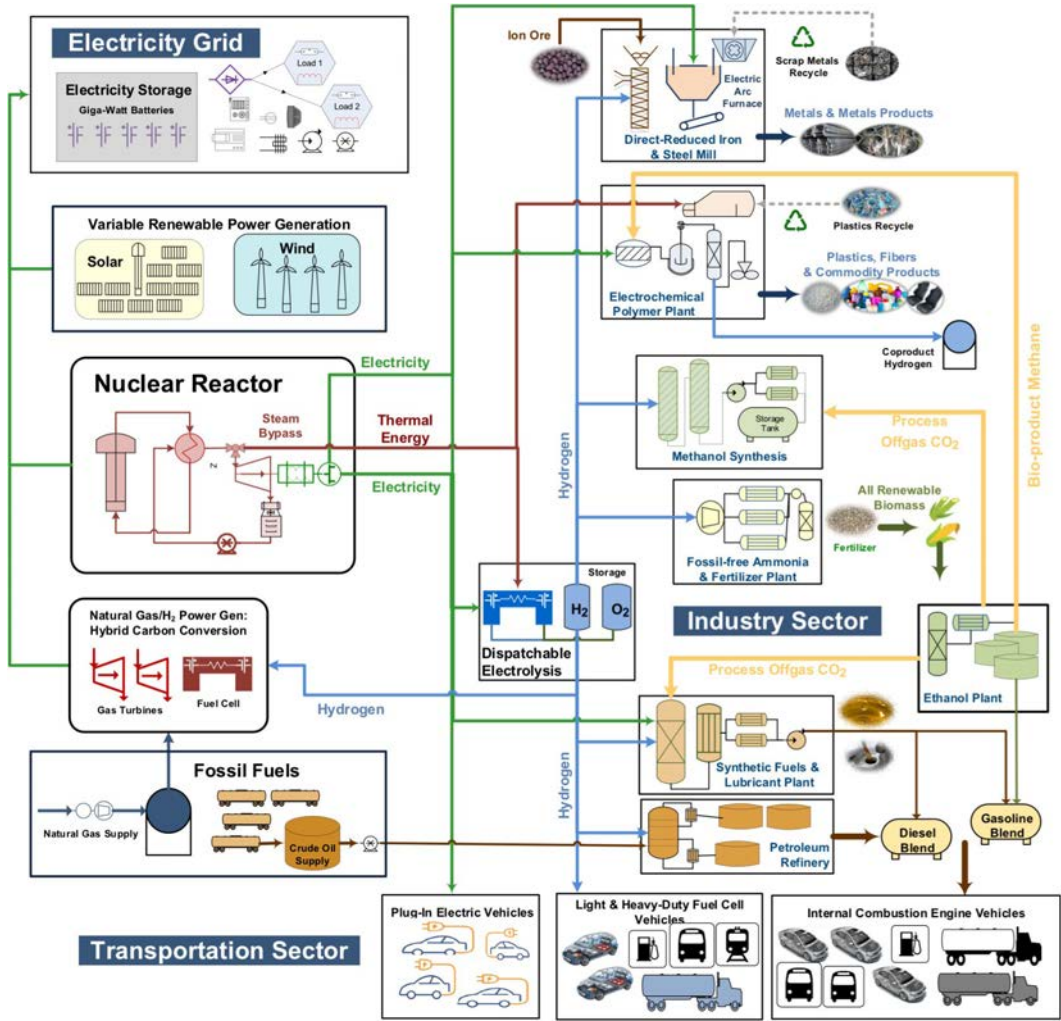


Figure 21. Direct integration of nuclear power plants with a large-scale hydrogen plants and affiliated industries.

for hydrogen produced by nuclear plants and is well known. In addition, hydrogen use in fuel-cell vehicles and as a substitute for natural gas are projected markets that would require changes to the infrastructure before commercial-scale hydrogen plants would be needed. Figure 21 illustrates the combination of current and future hydrogen markets that can be supported by LWR plants. A presentation of these options and the LWRs Program technical and economic assessments was given to U.S. petrochemical and chemical companies at the 2019 Annual Conference of the American Institute of Chemical Engineering.

To summarize, the evaluations completed in 2019 validated both the technical feasibility and economic viability of directly integrating LWR plants with these large industrial processes. In addition, the research proved that LWR thermal heat can be safely extracted using a steam bypass line. This heat can be used for HTSE. Market research performed by the LWRs Program validated the interest of industrial gas supply companies to invest in projects that produce hydrogen using nuclear energy because this would reduce the life-cycle emissions of CO<sub>2</sub> and other greenhouse gases at refineries, ammonia-fertilizer plants, and steel plants that would use this hydrogen

for their processes. This knowledge is driving the opportunity to match nuclear power plant owners with those industries. This work has also motivated DOE and industry to consider how a complex of manufacturing plants can be located near nuclear power plants. Engagement with the appertaining industries is now underway.

### **Development of the HERON Tool**

In 2019, the FPOG Pathway supported the development of the Holistic Energy Resource Optimization Network (HERON) tool, a newly developed Risk Analysis Virtual ENvironment (RAVEN) plugin for grid and capacity optimization. The tool is being used to complete technical and economic analyses of LWR-electricity dispatch, initially focusing on a deregulated market. HERON provides an algorithm built to handle complex and flexible grid configurations with nonlinear and unpredictable components. This makes it possible to optimize LWR-plant dispatching against an unbounded pricing structure. RAVEN wraps a set of submodels that include a physical representation of energy transport and use by HTSE for hydrogen production.

To demonstrate the efficacy of this new plugin, HERON was applied to a grid configuration containing an LWR-plant electricity producer, a hydrogen producer, hydrogen storage, an electricity market, and a hydrogen market. By economically choosing the dispatch of these components given a varying market price history, HERON demonstrated the ability to optimize dispatch (see Figure 22). By choosing the optimal size of each of these components, HERON demonstrated the ability to create the complex workflows required to incorporate randomly varying elements in technical and economic analysis.

This activity is important because it provides a tool that can help LWR owners evaluate options for increasing the revenue of their power plants in markets where it is becoming increasingly difficult to clear both the day-ahead and hour-ahead market price throughout the year. RAVEN/HERON will help inform strategic decisions as well as day-by-day operations of nuclear power plants. The HERON tool can be used to compare economic projections of various flexible plant operating conditions, to address a number of key questions including:

- Can the LWR provide load-following net power generation?
- Can the nuclear plant dispatch at a rate that meets spinning or non-spinning reserve capacity?
- What is the role for nuclear power reactors in achieving the clean-energy goals that are set by communities, states, commissions, and the utilities themselves?
- How can hybrid plants that face the grid while producing a second product, such as fresh water, optimize the profit of the nuclear plant?

Such questions require tools that can quantify the short-time scales of grid demand schedules over several years into the future.

### **Design and Demonstration of Nuclear Energy Direct Integration with Industry**

The purpose of this activity is to address human factors and control systems R&D that are needed to dynamically extract and deliver thermal energy from a nuclear power plant for use by an industrial process. This research is needed to ensure thermal energy extraction

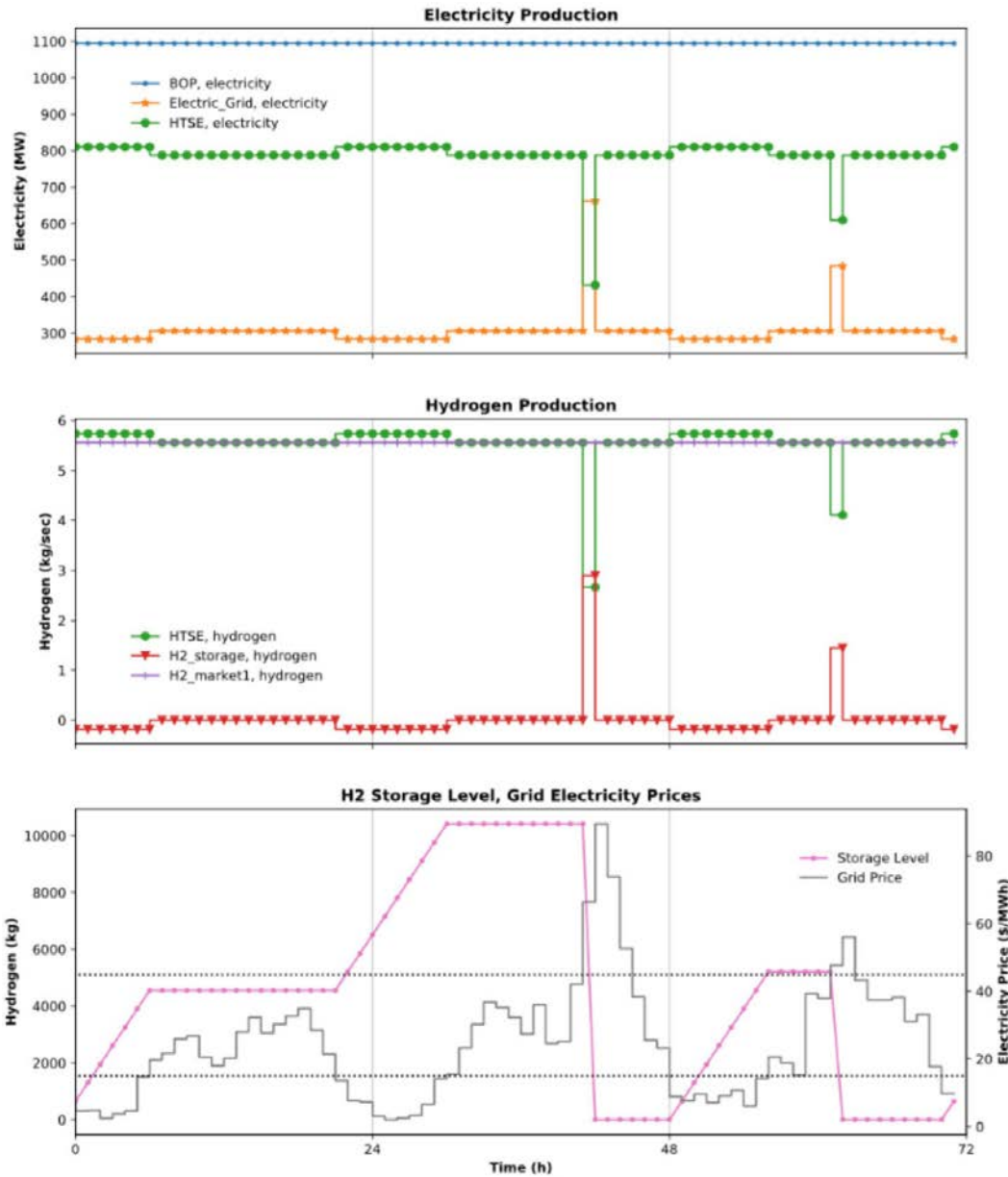


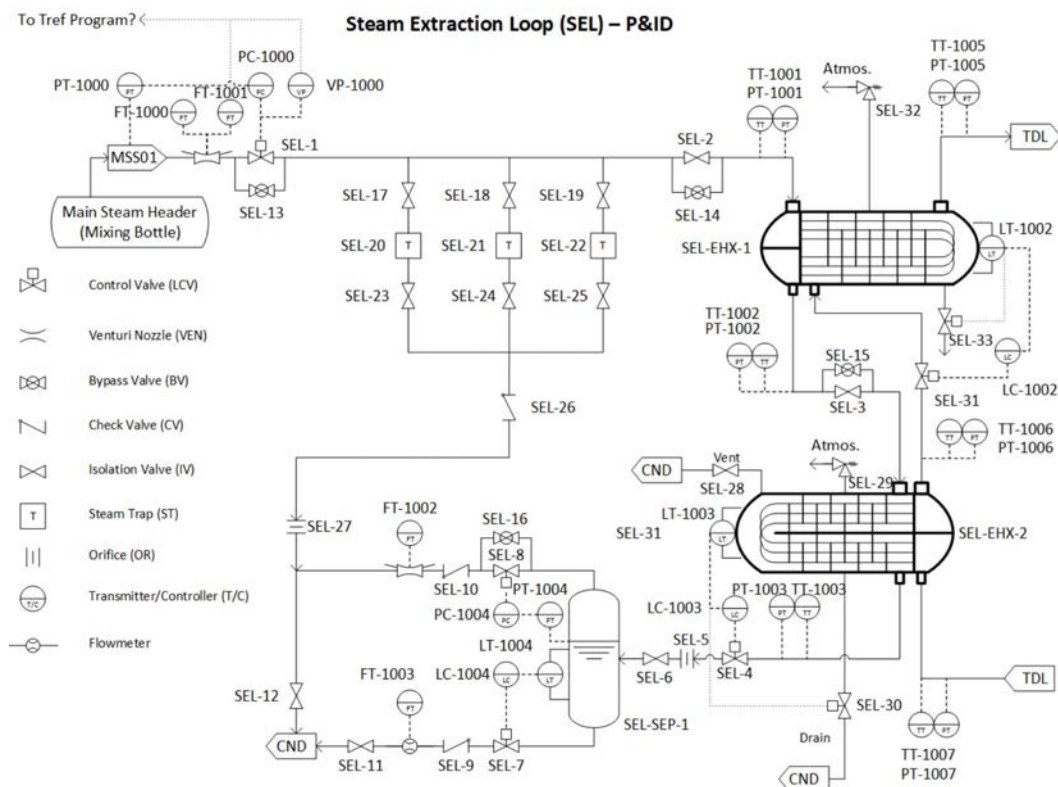
Figure 22. RAVEN/HERON optimal dispatch of electricity and hydrogen production and storage.

supports effective use by potential system operators and can be reliably integrated in the concept of operations for the operating plant. This research addresses important technical and safety issues vital to scaling hydrogen production and building out other industries, considering the uses of thermal energy produced by nuclear reactors.

### Extraction of Thermal Power from Nuclear Power Plants for High-Temperature Hydrogen Production

In 2019, an activity to address coupling an LWR to a high-temperature hydrogen production plant was initiated. A steam-extraction system was added to a generic pressurized water reactor (PWR) simulator provided by GSE Systems, Inc., based on a generic three-loop Westinghouse PWR with the turbine generator system comprising

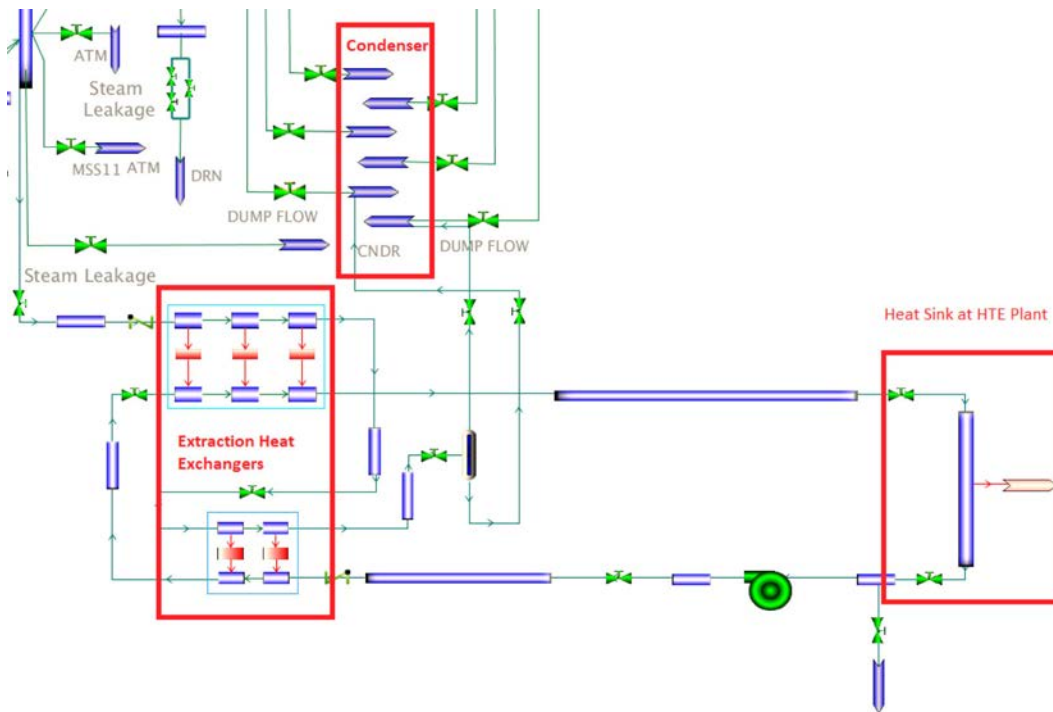
**Figure 23. Piping and instrumentation diagram of the proposed steam-extraction loop.**



one high-pressure turbine and two low-pressure turbines with two moisture separator reheaters. The piping and instrumentation diagram of the steam-extraction loop for this system is shown in Figure 23 while Figure 24 displays the addition of the steam-extraction loop from the main steam header to the condenser of the GSE simulator. When properly controlled, this loop allows for energy extraction from the LWR plant while maintaining 100% reactor power. The heat sink at the hydrogen plant is included in the simulation for thermal-inertia purposes and for continuity in the model to ensure computational stability in accordance with physical reality.

Several options were explored in the full-scope simulator to determine the best approaches to extract thermal power for hydrogen production, including extracting heat or steam from the main steam header and returning condensate to the condenser or feedwater heaters. Extracting heat from the main steam header using a heat exchanger was determined to be impractical because it could decrease steam quality to the high-pressure turbine below acceptable levels. Consequently, a design was developed to extract steam without impacting the quality of the steam being sent to the turbine power system.

The proposed systems may minimize modification to current nuclear operating licenses. The initial results from commercial nuclear power plant simulators show steady operation at 100% core power, with as much as 30% of the thermal energy being extracted from the secondary system while avoiding perturbations in the stability of the plant.



**Figure 24. Addition of a steam-extraction loop from the main steam header with heat exchangers and a heat sink at an HTSE plant in a generic PWR (important systems denoted by red boxes).**

In summary, the research completed in 2019 provides an addition to a full-scope LWR simulator that includes dynamic steam extraction exploitable by any steam user, including steam electrolysis. The simulator can be used to conduct research on the instrumentation, controls, and human-machine interface technologies needed to support deployment and effective use of an integrated energy system. The full-scope plant simulator can perform real-time simulation of all thermohydraulic, power, and control systems from the reactor neutronics to electricity generation and distribution. This initial work demonstrates how the controls and operation of a large thermal-energy user could be tied to a nuclear plant while extracting steam and electricity.

### Evaluation of Safety and Licensing Considerations

The goal of this effort is to evaluate the potential integration of energy offtake systems from the perspective of the operating and licensing basis of LWRs, considering the case of thermal energy delivery to an industrial user. Research was conducted to complete hazards and safety assessments that are used in probabilistic risk assessment (PRA) to support evaluation of electricity connections and thermal-energy extraction and of coupling to chemical plants, commencing with an HTSE hydrogen production facility tied to an LWR.

#### Initial PRA Efforts

Building on prior studies and utilizing preliminary design information of a high-temperature electrolysis facility, a preliminary PRA was performed in 2019. In

addition, potential licensing considerations were studied based upon presumed plant modifications or operational changes at an existing LWR.

A report, *Hybrid LWR System Licensing*, (Kurt Vedros and Courtney Otani, 2019, INL/LTD-19-55885) details a generic PWR PRA based upon the addition of a heat-extraction system to the secondary side of the PWR for use by a hydrogen-production facility. The PRA was performed to investigate two potential approaches that contribute to a decision on the need for a license amendment, studies of (1) the initiating-event frequency for a main steam-line break caused by the addition of a heat-extraction system, as shown in Figure 25, and (2) the initiating-event frequency of a hydrogen detonation. The report includes a literature survey of U.S. and worldwide hydrogen production and accident databases and blast calculations for a spherical-cloud detonation to determine probability of structural failure. These were placed into a hydrogen-plant detonation event tree, as shown in Figure 26.

The PRA was considered preliminary, because it both is generic and uses conservative assumptions to develop a bounding case. The results of the PRA indicate that the

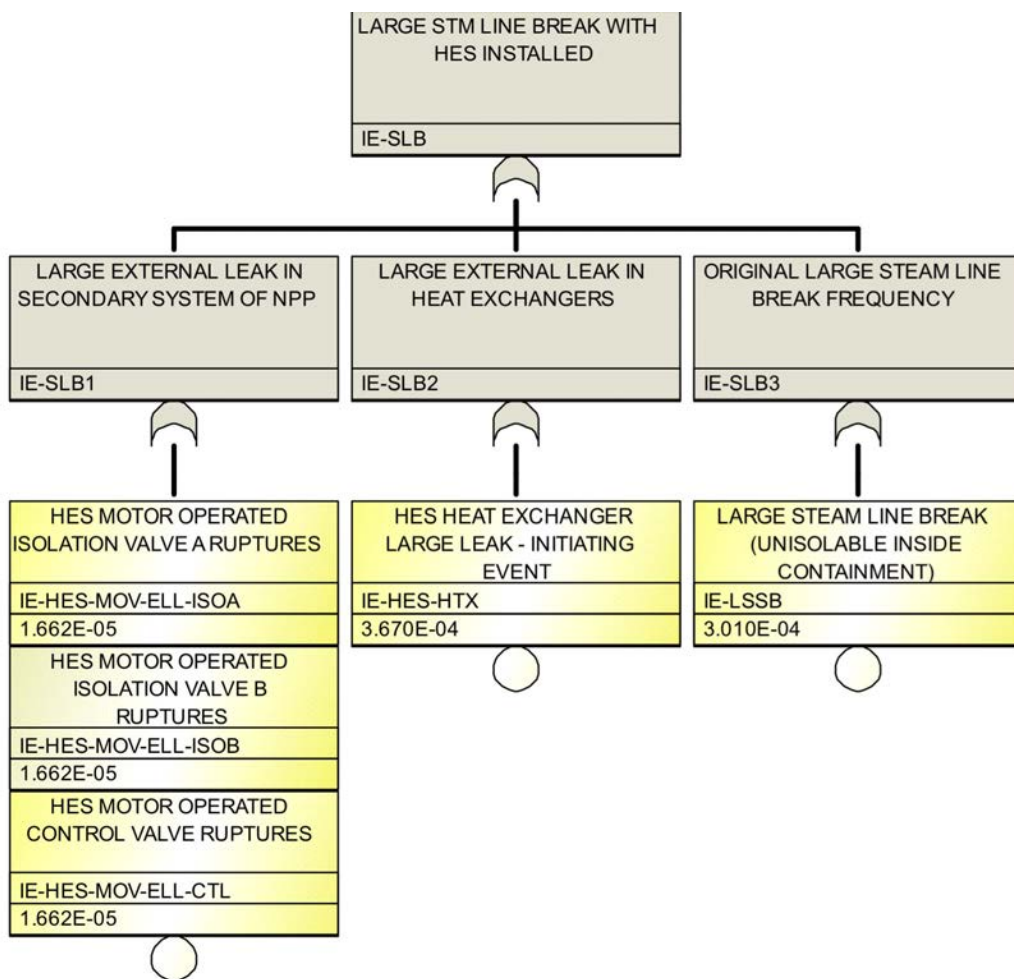


Figure 25. Steam-line break initiating-event fault tree with FPOG related hydrogen plants.

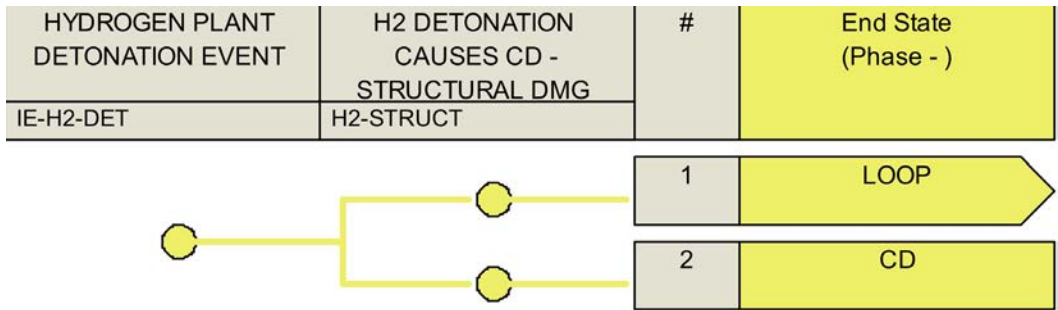


Figure 26. Hydrogen plant H<sub>2</sub> detonation event tree.

change in initiating-event frequency for some design-basis accidents may place a proposed design-and-operation case outside of criteria found in 10 CFR 50.59. The preliminary PRA results and corresponding estimates of core-damage frequency due to postulated events associated with modification and operation of the new systems may fall within a current operating license envelope using Regulatory Guide 1.174 to evaluate the proposed design changes.

Recommendations were made to further reduce assumptions and conservatism going forward. This may strengthen the case for the Regulatory Guide 1.174 licensing pathway and possibly identify approaches to using 10 CFR 50.59 as a viable licensing pathway.

In summary, these activities will inform the PRA for LWRs relative to potential safety and licensing considerations of flexible plant operations and generation that may fall outside a current operating-license basis. The thermohydraulic analysis of the heat-extraction system used to supply the industrial plant with process heat is conducted to identify the best approaches to thermal-energy extraction from the secondary systems of an LWR in consideration of PRA and license conditions. This effort provides initial results on the separation distance needed to minimize impacts to the licensing basis of a plant. Additional assessments will address chemical- or hydrogen-plant siting, operating conditions, and engineering measures that can be used to satisfy conditions of the licensing basis of candidate plants.

## Risk-Informed Systems Analysis

The Risk-Informed Systems Analysis (RISA) Pathway conducts R&D to enhance safety and improve plant economics in support of U.S. nuclear power plants over periods of extended plant operations. The pathway uses a combination of deterministic and probabilistic techniques applied together in a risk-informed approach to better characterize safety margins and reduce unnecessary conservatism in order to allow for greater flexibility in managing new technologies and operations within current safety margins. The RISA Pathway focuses on enhanced capabilities for analyzing and characterizing light-water reactor (LWR) systems performance by demonstrating and deploying methods, tools, and data in collaboration with industry and other stakeholders to enable improved safety- and economic-margins management.

The goals of the RISA Pathway are to: (1) develop and deploy risk-informed tools and methods to achieve high levels of safety and economic efficiencies and (2) conduct advanced risk-assessment applications with industry stakeholders to enable more cost-effective plant operation. The tools and methods provided by the RISA Pathway will support effective margin management for both active and passive safety systems, structures, and components (SSCs) in nuclear power plants.

The risk-informed tools and methods are applied in industry-application pilot projects. These pilot projects were developed through discussions with U.S. nuclear utilities in the following three areas: (1) enhanced resilient nuclear power plant concepts, (2) cost- and risk-categorization applications, and (3) margin recovery and operating-cost reduction.

Initiated in 2018, eight pilot projects are currently being conducted through the Pathway. They represent activities of risk-informed tools and methods in the areas of:

- Enhanced resilient plant systems
- Enhanced operation strategies for system components
- Risk-informed asset management
- Plant health management
- Enhanced fire PRA
- Modernization of design-basis accidents analysis with application on fuel-burnup extension
- Digital I&C risk assessment
- Plant-reload process optimization.

The research also addresses needed technical maturity of the tools and methods that are used in the pilot projects by assessing their verification and validation status and to support immediate improvements of risk-informed tools.

The RISA Pathway will continue to communicate with stakeholders to obtain feedback on current research, identify new issues, and carry out our near- and long-term plans for R&D that are responsive to the challenges of sustaining the existing LWR fleet. Figure 27 shows the current RISA Pathway program structure. The main R&D focus is



on the development of methods, tools, and data that are or will be applied to industry-supported pilot projects.

Select R&D highlights are provided here. Detailed reports covering the accomplishments can be found on the LWRs Program website (<https://lwrs.inl.gov>).

### Enhanced Resilient Nuclear Power Plant

#### Enhancing the Resilience of Pressurized Water Reactors with Accident-Tolerant Fuels, Flexible Coping Strategies, and Passive Cooling Systems

Enhancement of plant safety and economics are key issues in operating U.S. nuclear power plants. Viable options to enhance the current nuclear fleet include using accident-tolerant fuels (ATFs), diverse and flexible coping strategies (FLEX), and dynamic natural convection (DNC) passive cooling systems. These technologies have the potential of offering a longer coping time for operators to perform mitigating actions during abnormal operations or severe accident conditions. A longer coping time will support the use of FLEX equipment and accompanying mitigating strategies during postulated events and can contribute to nuclear power plants that are more resilient to off-normal events. In 2019, the RISA Pathway performed a scenario-based risk-informed study to quantify benefits from these technologies focusing on safety enhancements, risk reduction, and economics for PWRs.

The risk-informed analysis used integrated PRA and thermal-hydraulics calculations to analyze the impact of near-term FeCrAl and chromium-coated ATF on a generic Westinghouse 3-loop PWR. The accident scenarios included station blackout (SBO), loss of feedwater, steam-generator tube rupture, loss-of-coolant accident (LOCA), locked-rotor transient, turbine-trip transient, anticipated transient without scram, and main steam-line break.

The results show that using ATF can significantly reduce hydrogen production during a severe accident and that ATF could enhance fuel-cycle efficiency by increasing burnup

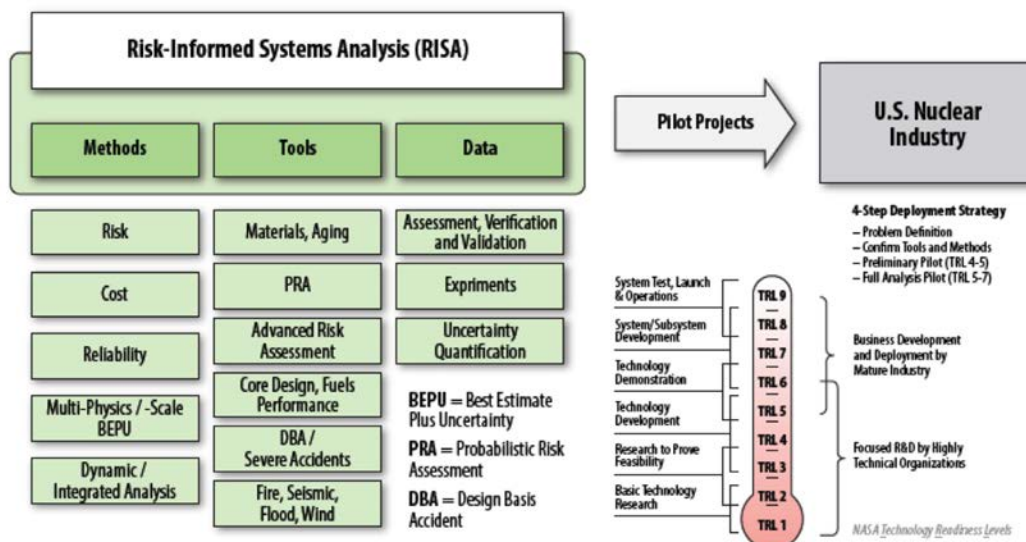
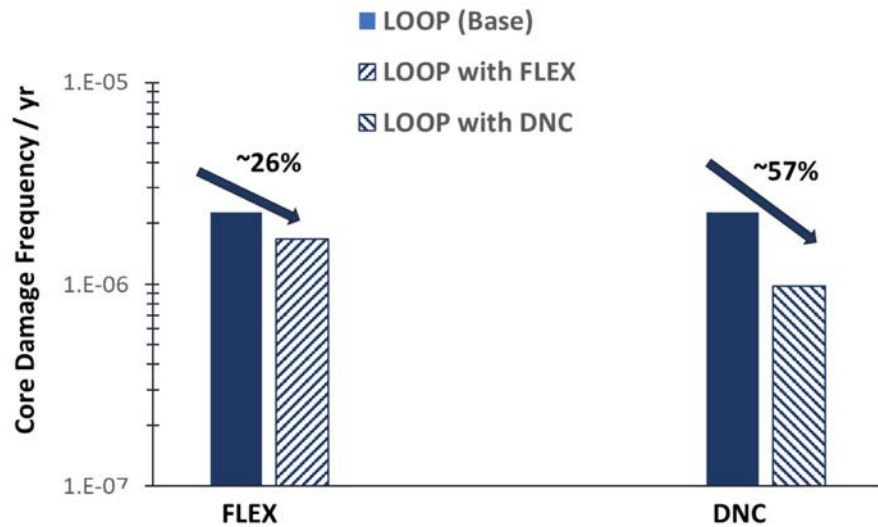


Figure 27. The RISA Pathway programmatic structure.

**Figure 28. Illustration of CDF Reduction with FLEX and DNC for LOOP/SBO scenario.**



extension and fuel enrichment by improving mechanical properties. A modest benefit was observed from increasing coping time and delaying the postulated onset of core damage. However, analysis using FLEX and DNC found an extended benefit: core-damage frequency (CDF) reduction. For the loss of offsite power (LOOP) SBO scenario, the analysis shows a 26% CDF reduction when using the FLEX system. About 57% of the CDF reduction was observed when the auxiliary feedwater system was replaced by a DNC system in a selected SBO scenario. As shown in Figure 28, it is concluded that the use of FLEX and a DNC passive cooling system could permit additional time to repair degraded or failed equipment and flexible and potentially longer periods between equipment surveillances—together these could provide improvements in economics by recategorizing some safety-related SSCs. The project will analyze a candidate boiling water reactor (BWR) using a set of reference scenarios and plans to carry out plant-specific case studies in coming years.

The RISA Pathway conducted an industry workshop related to this research. More than 40 experts from 19 different domestic and international nuclear-related organizations gathered for this workshop in Idaho Falls, Idaho, on July 30 and 31, 2019. The participants, shown in Figure 29, were briefed on current research and the variety of risk-informed approaches being considered and used in this research. They also contributed to discussions on developing a shared vision for future R&D collaborations.

In summary, this research has brought together industry stakeholders focusing on how different types of technology (both existing and new) can be used to demonstrate enhancements to safety and economics. The recent focus has been on improving plant resiliency through ATF, FLEX, and DNC and understanding the technical basis for crediting these systems. This work will support the future deployment of these different technologies, including the potential for evaluations where a combination of approaches (e.g., credit for both ATF and FLEX simultaneously) are used at a nuclear power plant.

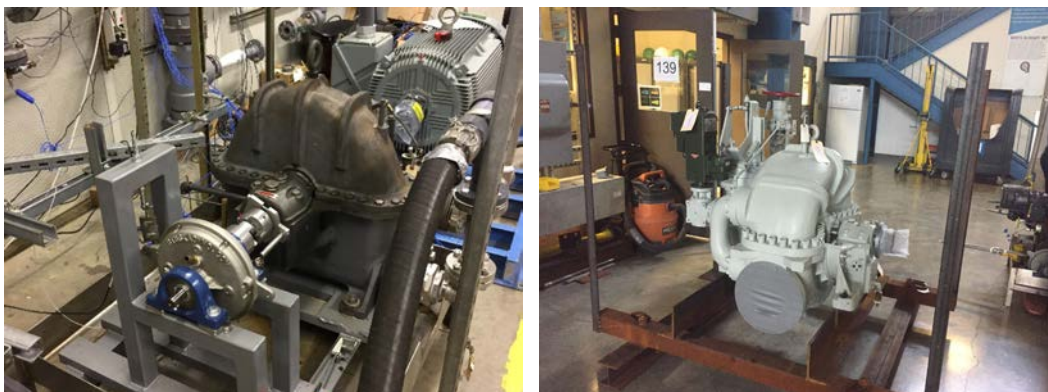


**Figure 29. Enhanced resilient plant workshop, held July 30 and 31, 2019, in Idaho Falls, Idaho.**

### Experiment on Terry Turbine System Operation Band Extension

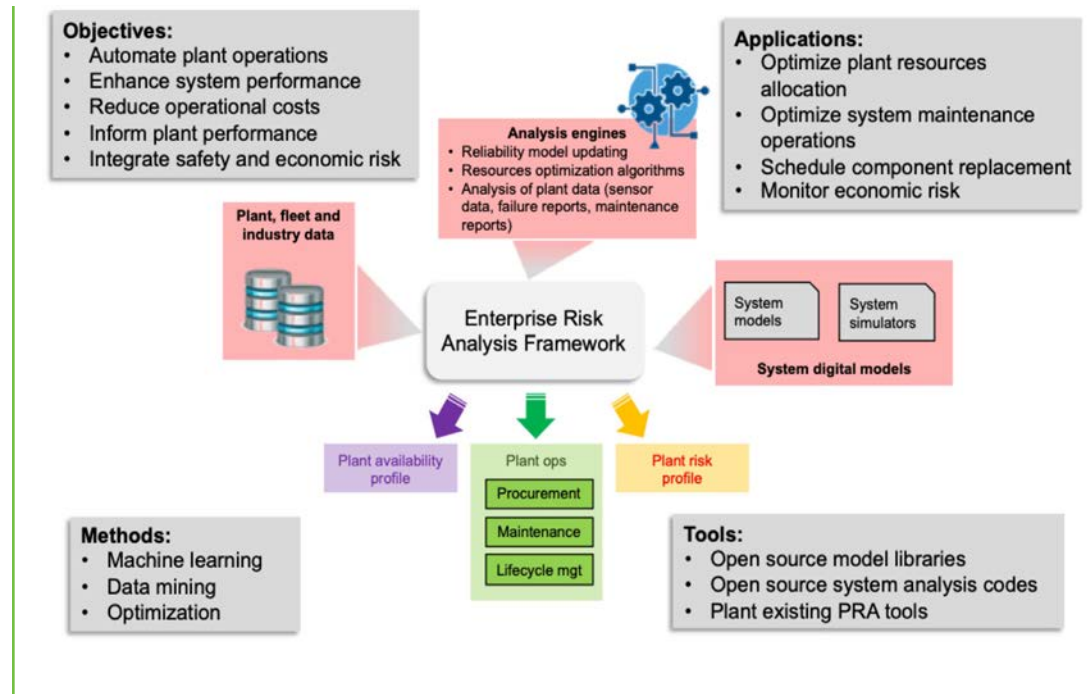
Thanks to its durability and low maintenance, the Terry turbine system, shown in Figure 30, is widely used in nuclear power plants for backup cooling. Generally, a Terry turbine in a BWR system is designed to operate with attached battery power for 4–12 hours [1]. However, it was observed that this system functioned in Fukushima Daiichi Unit 2 for almost three days, even after battery power was depleted. Hence, it became imperative to understand this observed self-regulating operation and behavior of this system.

LWRS Program researchers have participated in international collaborative research on the Terry-turbine extended operating-band program with nuclear industries in the U.S. and the Japanese Ministry of the Economy. The collaboration aims to characterize Terry-turbine behavior by understanding the physical phenomena that govern its behavior and operation through full-scale separate and integrated-effects experiments



**Figure 30. ZS-1 (left) and GS-2 (right) type Terry turbines.**

**Figure 31. RISA Pathway enterprise risk-analysis framework.**



and full-scale long-term low-pressure experiments. The program also includes research to improve modeling and simulation tools for the Terry turbine.

In 2019, LWRS Program researchers and Texas A&M University performed full-scale separate-effects experiments by using an 18-inch-wheel ZS-1 type Terry turbine, including nozzle and valve tests, turbine oil-degradation tests, and shakedown tests. Additional experiments were performed with air and air-water mixture flow behavior. A comparison study was also performed by using 24-inch-wheel GS-2 type Terry turbine. The experiment showed that the Terry turbine operated without failure even in the air-water mixture flow test. The experiment will continue for long-term low-pressure operation and Fukushima Daiichi Unit 2 simulation.

These experiments have shown, from the small-scale testing and simulation, that Terry-turbine systems may perform better than the conservative assumptions made in industry PRA models. Increased realism is introduced into industry PRA models for turbine-driven systems, with the goal of extending the credited coping time for systems that employ these or similar technologies in the operating fleet of nuclear power plants for important scenarios such as station blackout. Having more time to respond to off-normal events provides two immediate improvements, one to safety, as the plant risk is reduced, and one to economics because plants can potentially reduce reliance on the number of systems and operator actions credited today for accident response and, instead, focus on just the most important items to safety.

## Cost and Risk Categorization Applications

### Risk-informed Plant Asset and Health Management

Asset-management and equipment-reliability programs are an essential part of nuclear power plant safety and economic operation. The RISA Pathway is developing

an asset-management and equipment-reliability program by applying reliability- and risk-informed approaches to an enterprise risk-analysis framework. Shown in Figure 31, this framework uses a combination of data-analytics tools with risk-informed methods to optimize the management of plant assets over the remaining years of plant operation, including periods of license renewal. This automated framework can improve labor efficiency and reduce operational cost.

The enterprise risk-analysis framework under development is based on LWRS Program-developed Risk-Analysis Virtual ENvironment (RAVEN) code, which has unique, flexible capabilities to perform risk analysis, uncertainty quantification, sensitivity analysis, data mining, and model optimization. The RISA Pathway developed the following RAVEN capabilities for evaluating the impact of plant-asset and health-program modifications from a reliability and economic perspective:

- Capital budget optimization analysis capabilities through either deterministic or stochastic approaches, based on optimization algorithms
- SSC reliability and maintenance unavailability models, including generation-of-risk assessment models designed to evaluate the economic-risk scenarios under current nuclear power plant design
- Asset replacement and maintenance optimization software using sets of predefined workflows approaches to simplify the analysis
- Economic models for asset management and health program.

The development will continue in 2020, and initial demonstration of full-scale data-driven risk analysis for SSC refurbishment and replacement scenarios will be performed.

This research is providing a technical framework (through software and improved methods) to be able to evaluate how plant-equipment aging, maintenance, and probabilistic failures can be viewed through an economics model. By integrating asset information, including costs either not to replace components (e.g., the potential for failures and increased maintenance overtime) or to replace components (e.g., the asset costs) with plant operational knowledge and data, we can perform optimization focused on how components are treated over the lifetime of the nuclear power plant.

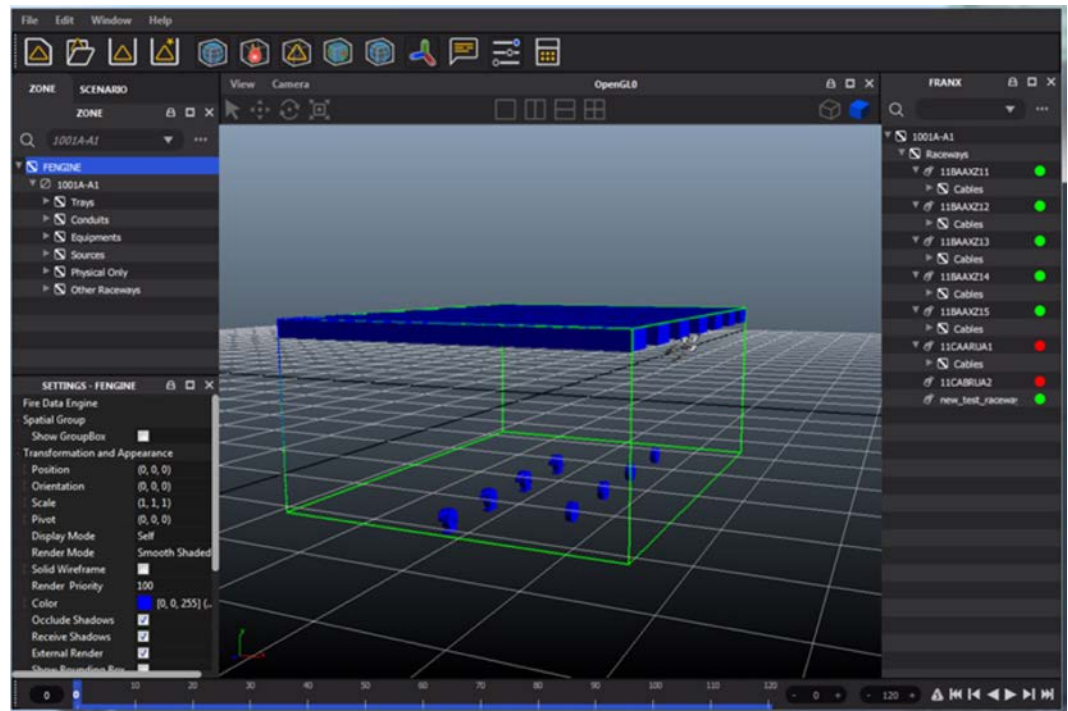
## Margin Recovery and Operating-Cost Reduction

### Fire Risk Investigation in 3D for Enhanced Fire PRA

Fire-safety analysis for a nuclear power plant has proven to be costly. The process of developing and maintaining risk models and ensuring proper safety measures commensurate with the analyzed risks is difficult and time-consuming. Several different tools can be used to evaluate a fire scenario, the results from which then need to be added to the facility PRA. Due to cumbersome modeling processes and associated uncertainties, a conservative approach has often been used to assess potential fire-related hazards, which may lead to overly high estimations of potential risks and expended resources to cope with them. Additionally, time-dependent fire modeling has not been performed to portray the evolution of risk-related work activities due to an historical lack of tools and computational limitations.

For the afore-mentioned reasons, the RISA Pathway initiated the development of risk-informed fire-hazard analysis software, Fire Risk Investigation in 3D (FRI3D), to

**Figure 32. FRI3D interface display.**



reduce unnecessary conservatism in fire-risk evaluations. Figure 32 is the interface display of the current version of the FRI3D software. With targeted delivery of software in 2021, the FRI3D software now can directly couple with an existing physics-based fire-analysis tool (e.g., the CFAST tool) for scenario-based simulation. In 2019, multidimensional spatial models and zoning and sectioning were added to existing fire-model capabilities. A failure-monitoring feature, which allows a user to evaluate and determine optimal mitigation time and methods based on postulated fire damage, was also developed. Software development will continue in 2020, adding a feature to automatically generate analysis scenarios to perform a cost-benefit analysis by using actual plant models, and to begin development of time-dependent support to enhance fire-modeling realism.

In 2019, LWRS Program researchers worked with external collaborators to import an industry fire model into the software and reviewed capabilities in order to make enhancements and obtain feedback. Further, researchers have extended the FRI3D capability to couple with the fire-simulation codes. This new feature allows auto-generated scenarios such that industry fire-modeling experts can verify the model using the new capability. This greatly reduces current efforts and reduces human errors when creating fire models. Software development will continue and will be used to perform cost-benefit analyses by using actual plant models to better understand the time needed for fire modeling.

In summary, this project has integrated different aspects of fire PRA tools into an improved approach to represent fire scenarios and to visualize the fire model in ways

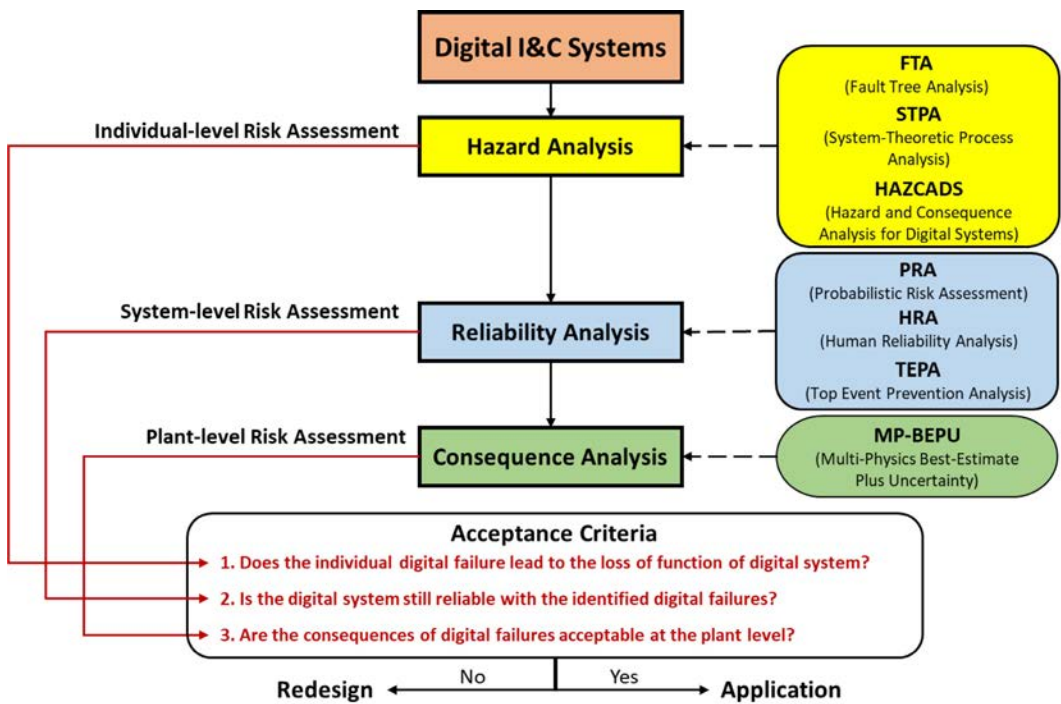


Figure 33. Schematic diagram of an integrated risk-assessment process for digital I&C.

that ensure robustness in the analysis. Working with industry stakeholders, the project enabled actual plant data in models in order to tailor these tools to industry needs. These successes will bring about efficiencies in fire risk-modeling practices in addition to increasing the fidelity of these models.

### Development of an Approach to Perform Integrated Risk Assessment for Digital Instrumentation and Control System Qualification

Replacing existing analog I&C systems with modern digital technology for safety-related applications offers performance improvement and cost reduction for nuclear power plants. However, the qualification of digital I&C-system reliability remains a challenge, especially due to the issue of software common-cause failures (CCFs), which have been historically challenging to address in regulatory applications. With upgrades to digital I&C systems, software CCFs need to be addressed because most redundant designs use similar digital platforms or software in the operating and application systems.

In this activity, research is evaluating typical digital I&C systems from the context of modern approaches for reliability. While some initial work was performed in the nuclear industry almost two decades ago on digital system reliability approaches, the state of practice has evolved. This research will leverage recent advancements in reliability analysis and use those approaches to analyze digital I&C systems. This research is conducted to support future anticipated license-amendment requests to use digital technologies.

In 2019, an approach was developed for developing a technical basis to support licensable and secure digital I&C technologies for use in nuclear power plants. The objectives of the research are to:

- Define an integrated risk-informed analysis process for a digital I&C upgrade, including hazard, reliability, and consequence analysis;
- Apply systematic and risk-informed tools to address CCFs and quantify responding failure probabilities for digital I&C technologies;
- Evaluate the impact of digital failures at the individual, system, and plant levels;
- Provide insights and suggestions on designs to manage risks, thus supporting the development, licensing, and deployment of advanced digital I&C technologies for nuclear power plants.

An integrated risk-assessment approach for digital I&C was also proposed that includes hazard, reliability, and consequence analysis. The goal of this integrated approach is to identify important digital I&C failures, assess the reliability of these systems, and evaluate the consequences of postulated failures (particularly software CCFs) on plant performance. *Risk analysis* aims to identify digital I&C hazards, estimate the probability of their occurrence, and analyze consequences of their occurrence. The results from risk analysis are compared with acceptance criteria, as displayed in Figure 33.

*Hazard analysis* focuses on identifying both software and hardware failures by using fault-tree analysis and systems-theoretic process-analysis methods, building integrated fault trees for the failure top events of the system or component of interest. *Reliability analysis* aims to quantify integrated fault trees, produce importance measures from the basic component and failure combinations, and build event trees that support consequence analysis of the postulated digital system failures. *Consequence analysis* includes uncertainty and sensitivity analysis conducted in a multiscale, multiphysics environment to evaluate the impact of the consequences of digital-system failures postulated in the reliability analysis.

Once all of the acceptance criteria are satisfied, digital I&C systems of interest may be considered safe for an application. Otherwise, redesign is required to improve the safety of these systems. This approach will provide risk insights to augment the current defense-in-depth and diversity analyses of digital I&C designs. In 2020, the PRA method will be introduced to evaluate and support defense-in-depth and diversity applications based on their safety, risk, and cost significance.

In summary, this activity brings best practices and recent enhancements in reliability modeling to support future licensing processes for digital I&C systems. The research has initially focused on providing an integrated assessment process; working with industry collaborators, it now demonstrates this process through trial application using plant-specific information.

### References

1. K. Ross, et. al., 2105. "Modeling of the Reactor Core Isolation Cooling Response to Beyond Design Basis Operations—Phase 1," SAND2015-10662, December.



## Materials Research

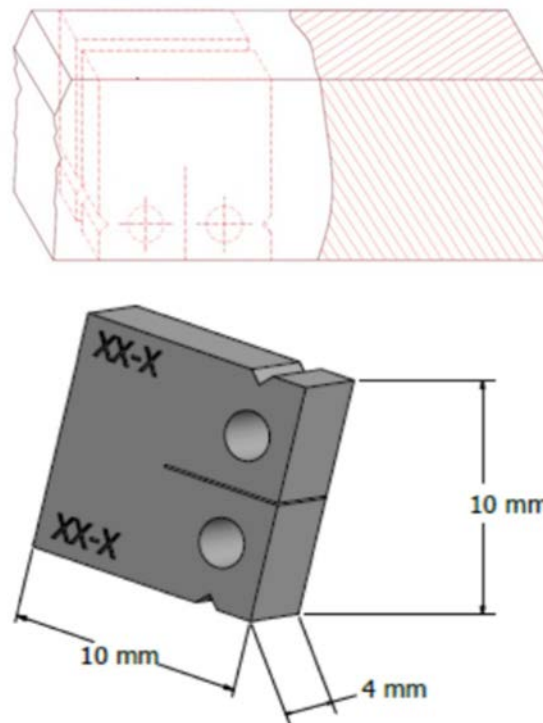
**M**aterials research provides an important foundation for managing the long-term, safe, and economical operation of nuclear power plants. Understanding aging mechanisms and their influence on nuclear power plant materials that comprise SSCs, with sufficient confidence, provides critical support for planning, investment, and continued safe and economical operation of existing plants. Moreover, predicting, controlling, and mitigating materials degradation are key priorities during periods of extended plant operation. The strategic goals of the Materials Research Pathway are to develop the technical basis for understanding and predicting long-term environmental degradation and behavior of materials in nuclear power plants and to provide data and methods to assess performance of SSCs essential to safe and economically sustainable operation of nuclear power plants. This includes methods for monitoring and measuring degradation to understand aging mechanisms and to model materials and component performance towards developing strategies to mitigate the effects of aging.

Select R&D highlights are provided here. Detailed reports covering the accomplishments can be found on the LWRs Program website (<https://lwrs.inl.gov>).

### Validation of Mini Compact Tension Specimens for Fracture Toughness Characterization of Reactor Pressure Vessel Steels

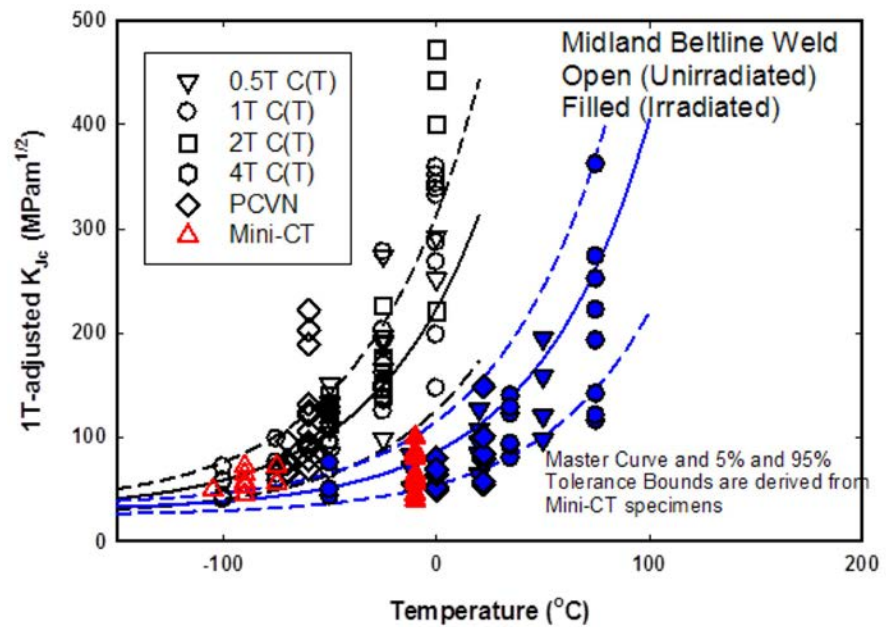
Surveillance capsules located inside reactor pressure vessels (RPVs) of commercial reactors achieve radiation-damage exposures faster than the wall of the RPV, providing insight into the future performance of the vessel in anticipation of that observed in the actual vessel. The Charpy V-notch test specimen is the most commonly used geometry in surveillance programs and the most likely to be used in advanced reactors as per American Society of Mechanical Engineers code. However, fracture-toughness assessment of these materials requires indirect correlations to the Charpy impact specimens that may result in potential bias of the test data, especially at very high fluences that are of interest for extended operating-life conditions.

Fracture toughness specimens that can be made from the broken halves of standard Charpy specimens may have exceptional utility for evaluation of RPVs since they would allow researchers to determine and monitor actual fracture toughness. Minicomact tension (mini-CT) specimens are becoming a popular geometry for use in the RPV community for direct



**Figure 34.** Layout of mini-CT within a broken Charpy specimen half (of a surveillance weld-metal) and overall dimensions of the mini-CT specimen.

**Figure 35. Fracture toughness data of unirradiated and irradiated Midland beltline weld from the present study using mini-CT specimens and conventional specimens in [1]. Master Curves and Tolerance bounds are derived from mini-CT data only.**



measurement of fracture toughness in the transition region using the master-curve methodology, based upon guidance found in American Society for Testing and Materials (ASTM) Standard E1921 for evaluating RPV integrity. The advantage of the mini-CT specimen technique stems from a net shape similar to the standard Charpy specimen that can be made from the broken half of a previously tested Charpy specimen obtained from a standard RPV surveillance capsule. Although it results in a very small specimen, the thickness of this mini-CT specimen is sufficient to fit in a very narrow validity-limit window allowed by ASTM E1921. Figure 34 illustrates the layout of mini-CT specimens within a broken Charpy half and the overall dimensions of the specimen. This example shows that, typically, two mini-CT specimens can be machined from one broken half of a surveillance-weld metal Charpy specimen, and four can be created from a surveillance base-metal Charpy specimen.

Until now, the validation of mini-CT specimens has been performed on non-irradiated base metals, and only recently has limited work been performed on weld metals, which can produce more sample variability and can be more sensitive to aging effects. Expanding on this early work, the Materials Research Pathway set out to validate the uses of mini-CT specimens on weld material with reduced-impact properties (low upper-shelf) in both unirradiated and irradiated conditions. This type of RPV beltline weld can be a limiting material during the extended life of the current fleet of U.S. reactors. The low upper-shelf Linde 80 weld, designated WF-70, has been selected for this study. This weld was used in the Midland Reactor Unit 1 beltline weld and was previously well characterized at Oak Ridge National Laboratory (ORNL) using various conventional fracture-toughness specimens in both unirradiated and irradiated conditions. That fact is critical because it made this study efficient by reducing the need to perform a large testing program with conventional specimens and obviating the need to perform an expensive irradiation campaign. To complete this task, an informal international partnership was formed, with acknowledged contributions from Drs. Masato Yamamoto from Central Research Institute of Electric Power Industry,

Robert Carter from the Electric Power Research Institute (EPRI), William Server from ATI Consulting, and Brian Hall from Westinghouse. Without their invaluable contributions, this project would have been hard to accomplish.

Figure 35 illustrates the 1-T adjusted fracture-toughness data for a Midland beltline weld WF-70 from the present studies using larger specimens in the unirradiated and irradiated conditions and compared with data derived using mini-CT specimens. These results (in red) are superimposed on the fracture-toughness database for the Midland WF-70 weld previously produced by Materials Research Pathway researchers at ORNL using conventional specimens in both the unirradiated and irradiated conditions. Overall, the transition temperature ( $T_0$ ) values derived from a relatively small number of mini-CT specimens in this study are in remarkable agreement with values from previously reported fracture-toughness data. The master curve and 5% and 95% tolerance bounds are based on the current study's mini-CT data and envelop the scatter exhibited on a large set of variously sized conventional specimens over a wide temperature range.

In summary, this study indicates areas that should be addressed in the current ASTM E1921 standard, which require future development and clarification for adopting this small specimen for wide use in surveillance-specimen testing. The mini-CT specimen and its validation through this research would provide a powerful tool for direct fracture-toughness characterization of RPV materials using already available Charpy surveillance specimens. This would enable the industry to better assess RPV integrity and reduce potential bias and uncertainties in assessments of material performance and estimations that use these data. The lessons learned from these studies also apply to other industries where important decisions on materials management are made, but where only limited material may be available for testing.

### **Evaluation of Stress Corrosion Crack Initiation in Nickel-Base Alloys and Implications for PWR Components**

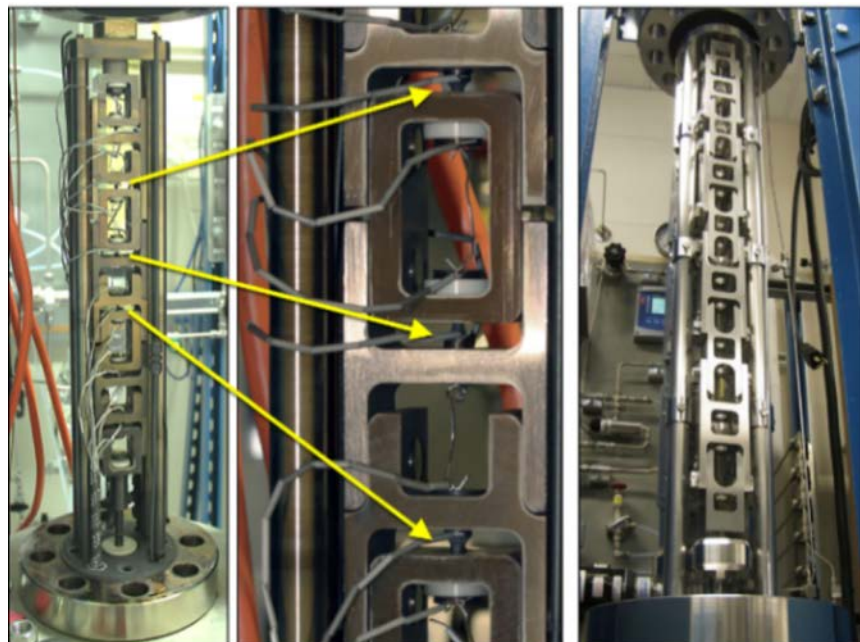
Understanding and managing stress corrosion cracking (SCC) of Ni-base alloys used in light-water reactor (LWR) pressure-boundary components is vital to the long-term operation of the nation's nuclear fleet. SCC of the originally selected low-Cr Ni-base Alloy 600 and its weld metals used in steam generators and to join piping and instrumentation nozzles to the reactor vessel began to significantly impact PWR performance in the 1980s and 1990s, which led to their progressive replacement in these components [2]. Although service performance has been restored through either application of mitigation techniques or replacement with high-Cr Ni-base Alloy 690 and its weld metals, Alloy 600 and its weld metals remain in use in certain regions of the reactor where viable mitigation techniques are still being developed. Meanwhile, SCC susceptibility has been identified in the laboratory for Alloy 690 [3], prompting a need for further assessment of SCC susceptibility for both the materials.

This project addresses one of the least understood aspects of SCC for LWR pressure-boundary components: crack initiation. Our focus is to investigate important material (e.g., composition, processing, microstructure, and strength) and environmental (e.g., temperature, water chemistry, and stress) effects on SCC initiation susceptibility of Alloys 600 and 690. The primary objectives of these studies are to identify mechanisms controlling crack nucleation, investigate the transition from short to long crack growth

under realistic LWR conditions, and establish the framework to effectively model and mitigate SCC-related initiation.

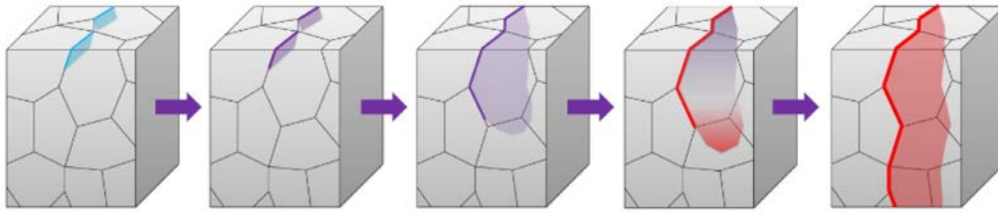
Three state-of-the-art multispecimen SCC initiation testing systems were designed and built at Pacific Northwest National Laboratory (PNNL) as shown in Figure 36. The successful implementation of these advanced test systems and methods under the project has provided a foundation for SCC initiation studies at the U.S. Nuclear Regulatory Commission (NRC) and EPRI [4], as well as helping to establish the standard for LWR SCC initiation testing around the world [5]. To date, SCC initiation tests have been performed in simulated PWR environments on both Alloy 600 and 690 to evaluate the effects of key material and environmental factors on crack precursor development. For cold-worked (CW) Alloy 600, SCC initiated at the specimen surface following intergranular (IG) attack and grew into the bulk material. By contrast, CW Alloy 690 exhibited internal IG damage in the form of grain boundary cavities, which eventually led to cracks connected to the specimen surface. The different crack initiation and growth mechanisms for Alloys 600 and 690 are illustrated in Figure 37.

SCC initiation data from this project and another at PNNL [4] have enabled an estimation of the factor of improvement for Alloy 690 versus Alloy 600 in 360°C PWR primary water as shown in Figure 38. SCC initiation time of less than 1,000 hours was frequently detected in all CW Alloy 600 materials, most of which are in the 15% CW condition. In comparison, SCC initiation has not been detected in any of the low-to-moderate CW Alloy 690 materials surpassing 27,000 hours of exposure at constant load. This suggests the Alloy 690 SCC initiation factor of improvement is *greater than 25*, and this number is still increasing with continued testing. However, crack initiation has been detected in a highly CW Alloy 690 heat after approximately 15,400 and 22,240 hours. All of this information is of critical importance for the prediction of material degradation and plant-life management for existing PWR systems.

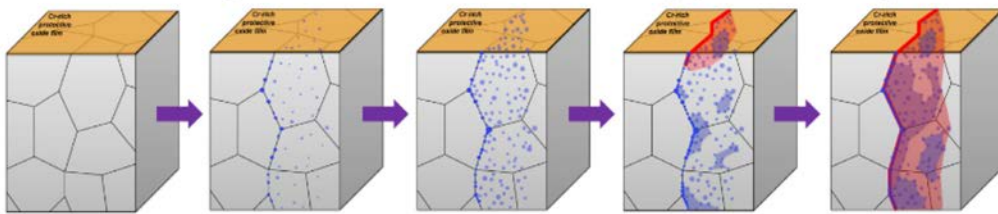


**Figure 36. Small SCC initiation test system with instrumented specimens (left side) and the large SCC initiation test system (right side) at PNNL.**

**Cold-worked Alloy 600: SCC initiation induced by intergranular attack**

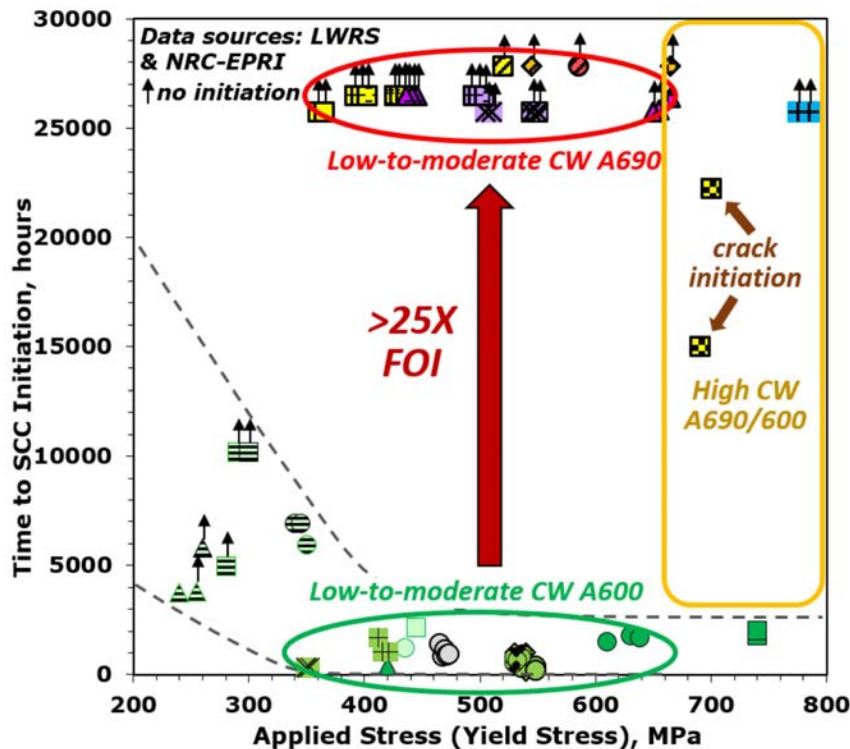


**Cold-worked Alloy 690: crack initiation induced by grain boundary cavities**



*Figure 37. Proposed crack initiation and growth mechanism for CW Alloy 600 (top) and Alloy 690 (bottom) based on experimental observations.*

In summary, ongoing SCC initiation research that combines advanced testing and characterization techniques provides unique insights into the mechanisms and precursor states for SCC initiation in Ni base alloys. This knowledge is enabling the factor-of-improvement assessment for replacement Alloy 690 and the development of quantitative models to assess the performance of existing Alloy 600 and 690 components. In addition, the basis for improved SCC-resistant alloys and mitigation strategies are being evaluated, all of which are of high interest to the nuclear industry.



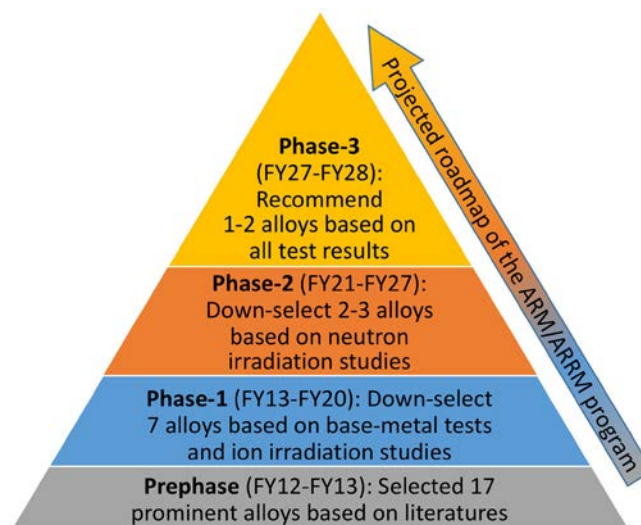
*Figure 38. Measured SCC initiation time as a function of applied stress for CW Alloy 600 and Alloy 690.*

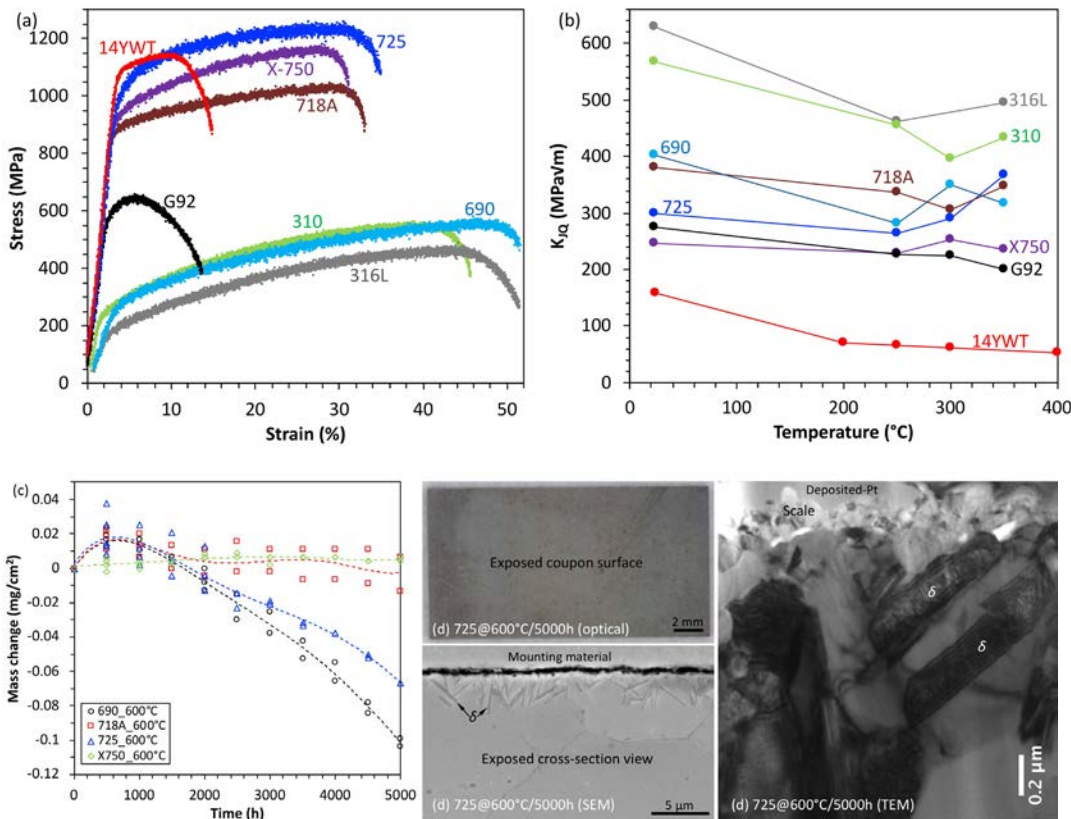
## Development of Advanced Replacement Materials for Light Water Reactor Internals

Advanced alloys are needed for advanced reactors and replacement components for current LWRs. Advanced alloys will allow reactors to operate with greater efficiency and lower maintenance, inspection, and repair costs. Advanced replacement materials (ARM) for LWR internals is one of the mitigation strategies for life extension of LWRs being investigated by the Materials Research Pathway. ARM research has collaborated with the Advanced Radiation-Resistant Materials (ARRM) program, led by the EPRI, since 2012. As summarized in Figure 39, the preliminary phase of the ARM/ARRM programs was initiated in 2012 and published in an EPRI technical report entitled *Critical issues report and roadmap for the ARRM program* in 2013. The report summarizes seventeen selected, prominent candidate alloys and the planned R&D activities in Phases 1, 2 and 3 to accomplish the objectives of this program—i.e., to down select and develop one or two advanced alloys with superior radiation resistance for core internal-support components and fasteners as replacement internals for current LWRs and new internals for future reactors.

In Phase-1 of this R&D, efforts focused on alloy procurement and property assessment of base metals and the corresponding proton and  $\text{Fe}^{2+}$  irradiated metals. Alloy procurement was led by researchers from the EPRI, ORNL, General Electric, and Knolls Atomic Power Laboratory. Property assessment—including tensile properties, fracture toughness, steam oxidation resistance, SCC, radiation-hardening, irradiation-assisted SCC (IASCC), swelling, and associated microstructural characteristics—was primarily conducted at ORNL and the University of Michigan. Figure 40, a-b, show examples of tensile curves at 300°C [6] and fracture toughness at elevated temperatures [7] for eight alloys. The time-dependent mass changes of four Ni-base alloys exposed to steam at 600°C are shown in Figure 40, c. The microstructures of alloy 725 exposed to steam at 600°C for 5,000 hours are exemplified in Figure 40, d, in a surface view of the exposed coupon by optical microscopy and in a cross-section view of the oxide

Figure 39. Projected roadmap of the ARM/ARRM program.





**Figure 40. Examples of (a) tensile curves at 300°C, (b) fracture toughness at elevated temperatures, (c) time-dependent mass changes of Ni-base alloys exposed to steam at 600°C, and (d) microstructures of alloy 725 exposed to steam at 600°C for 5,000 hours.**

scale and the substrate by scanning electron microscopy and transmission electron microscopy (TEM) [8].

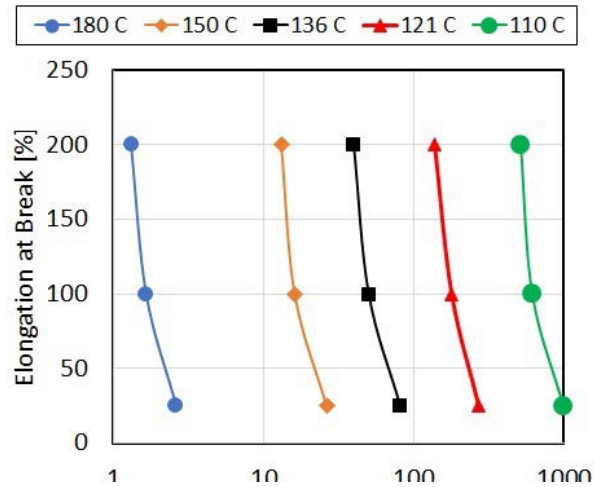
Phase-1, which down-selected seven alloys based on base-metal testing and ion-irradiation studies, will be concluded in 2020. These seven alloys exhibit the best balanced properties and include:

- Ferritic-martensitic steel Grade 92
- Austenitic stainless steel 310
- Three Ni-base alloys: 690, 725, and 718A
- Two reference alloys: 316L (austenitic stainless steel) and X-750 (Ni-base alloy).

Among the seven alloys, Grades 92, 310, 690, and 316L are considered low-strength and 725, 718A, and X-750 are high-strength alloys. Other candidate alloys initially considered were not selected for further evaluations because of either difficulties fabricating the material to obtain desired microstructures (e.g., Alloy 439 and 14YWT), poor irradiated fracture toughness at the LWR-relevant temperatures (e.g., Ti alloys and HT9), undesired material characteristics in severe accident scenarios (e.g., Zr-2.5Nb), or poor IASCC performance (e.g., Alloys 625, 625-direct-age, 625-plus, C22, and 800).

Partnering with LWRs Program researchers at ORNL, the University of Michigan, Idaho National Laboratory, and PNNL, EPRI is leading the effort to initiate Phase 2 studies on the radiation response of the seven alloys using the High Flux Isotope Reactor of ORNL.

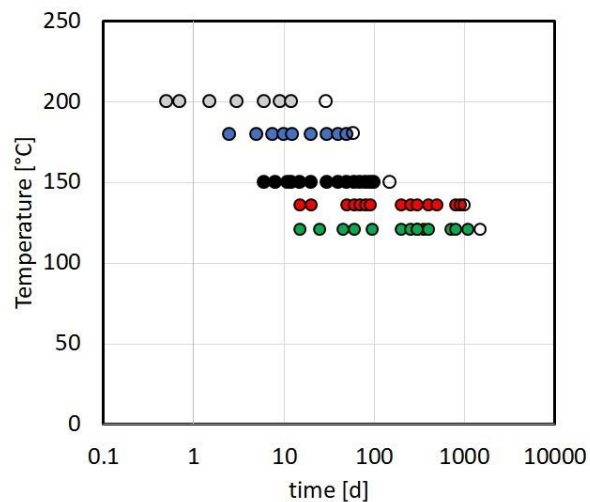
**Figure 41. EAB for BIW (Isolierstoffe GmbH) insulated cable from EQ documentation from the Zion nuclear power plant after accelerated aging at different temperatures.**



### Development of Remaining Life Model for Nuclear Grade Cables based on Correlations between Ultimate Electrical Performance Limits and Mechanical and Chemical Properties

Understanding degradation mechanisms in cable insulation and jacket materials is essential to determine the remaining useful life of cables in service in operating nuclear power plants beyond their original 40-year planned operating life. By incorporating information about degradation mechanisms with nondestructive evaluation (NDE) techniques and predictive models, nuclear power plant cable aging management programs can significantly reduce time spent during maintenance activities focusing on cable materials and environmental conditions. These require attention and postpone removal of cable systems with sufficient remaining useful life. LWRS Program researchers at ORNL and PNNL, in cooperation with the EPRI and the NRC, are developing an understanding of degradation mechanisms from harvested cable insulation to assure that issues relevant to nuclear power plants are addressed in a timely manner.

**Figure 42. Time to failure (open circle) of Zion nuclear power plant EQ documentation BIW insulated cable from 5-minute, 2.4 kV AC withstand after accelerated aging at different temperatures and LOCA exposure consistent with IEEE 323-1974 and 383-1974 standards.**

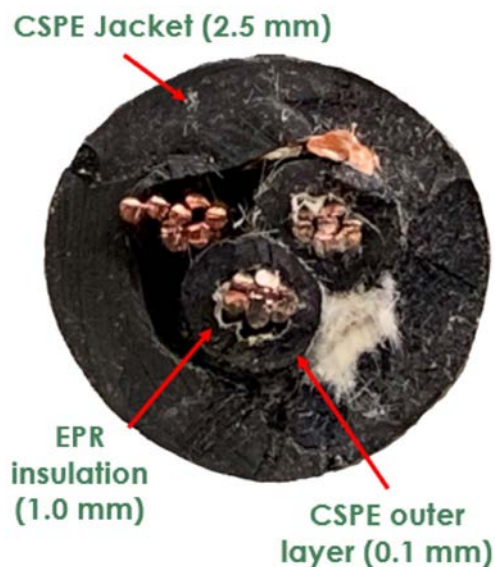




Research at ORNL has focused on understanding correlations between the ultimate electrical performance of low- and medium-voltage cable insulation and the insulation's mechanical and chemical properties. The motivation for this work, as shown in Figure 41 and Figure 42, is that mechanical and electrical performance of nuclear power plant cable insulation varies as a function of aging temperature. An insulation's elongation at break (EAB) of 50% has been used as an indicator of an insulation's remaining useful life at extended operation. When compared to the environmental-qualification (EQ) documentation (Figure 42) for an electrical measurement (i.e., alternating current [AC] withstand voltage), a noticeable difference is observed between the time to failure as predicted by EAB and the AC withstand measurement. EQ documentation assumes that the rate of degradation, which is quantified by activation energy, is the same for electrical and mechanical properties. With plants operating beyond their 40-year lifetimes, the questions are:

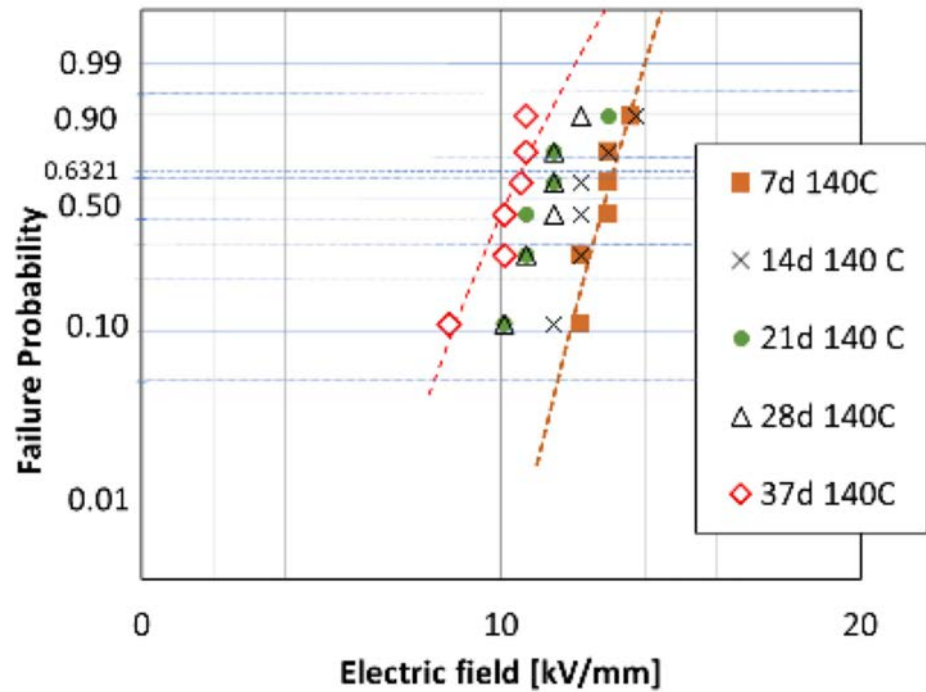
1. Is this assumption still valid?
2. Is this assumption valid across other electrical characterization techniques, such as electrical breakdown and permittivity that are easier to obtain than loss-of-coolant accident (LOCA) testing shown in Figure 42?
3. Could this additional electrical- characterization data be used to complement predictive models to inform cable aging management programs with a higher degree of fidelity?

In this work, the phenomenon of electrical breakdown was examined in the context of aging, low-voltage, harvested ethylene propylene rubber (EPR) and chlorosulfonated polyethylene rubber (CSPE) cable insulation and jacket materials. Multiple insulation samples were prepared from BIW manufactured cables harvested from the decommissioned Zion Unit 2 nuclear power plant. The materials were aged at multiple temperatures, and their electrical breakdown and indenter modulus were quantified as a function of temperature and time. The indenter modulus was initially used instead of EAB because it is a nondestructive measurement, allowing the same samples to be tested for electrical breakdown (Figure 43). Degradation was observed in electrical



**Figure 43. Example of BIW EPR/CSPE cable cross section.**

**Figure 44. Weibull distribution of electrical- breakdown strength for BIW EPR/CSPE Zion insulation after thermal accelerated aging with respect to temperature and time.**



breakdown as insulation was aged (Figure 44), and the drop in Weibull average value,  $\alpha$ , corresponded to an increase in indenter modulus across multiple temperatures (Figure 45). However, when accelerated aging across comparable temperatures and electrical and mechanical measurements were made on a second BIW EPR/CSPE insulation type, which had a thicker CSPE jacket by a factor of four and total insulation thickness of 1.4 mm, retention of electrical- breakdown strength was observed with the electrical breakdown strength above 60 kV/mm, which is three-times higher than what was observed in Figure 43.

As a first assessment, the electrical breakdown characterization technique was able to assess a cable insulation's remaining useful life as degradation was observed mechanically in the insulation. However, retention of electrical breakdown strength that was observed in a comparable insulation material system suggest the need for a closer examination before drawing a definitive conclusion. Outside of the physical differences between the insulations, the harvesting locations were different for the two insulations, with the insulation in Figure 43 harvested from conduit near motor operating valves while the other was harvested from an auxiliary instrumentation conduit. This could indicate that the amount of aging that each experienced was different, but additional work is needed to confirm these differences. Given the available cable insulation samples that have been harvested from the Crystal River 3 Nuclear Power Plant, extended characterization across insulations with respect to plant location and material composition could be performed using tools such as EAB and Fourier-transform infrared reflectometry characterization. These have shown an ability to track degradation and electrical-breakdown strength to effectively inform predictive models.

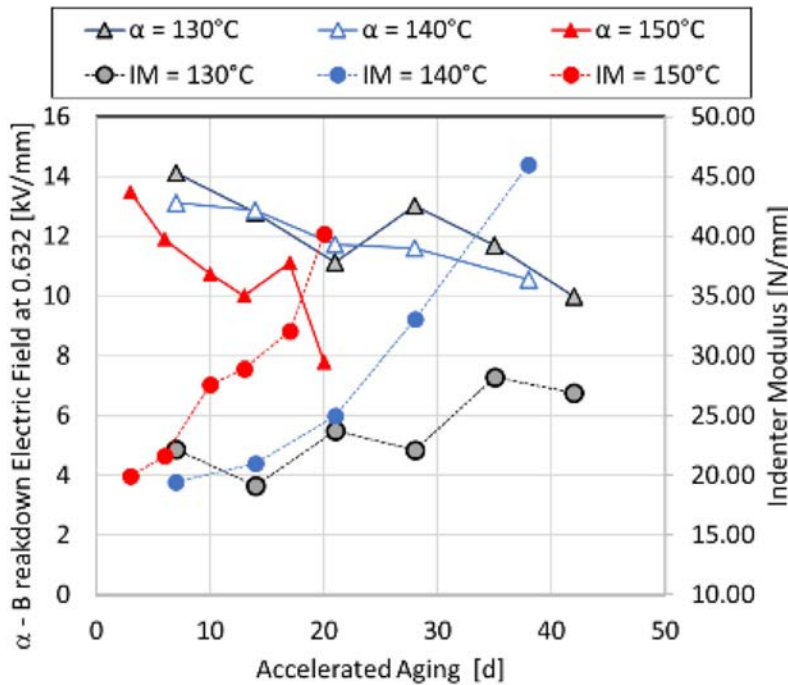


Figure 45. Comparison of Weibull scale parameters  $\alpha$  for BIW (Zion) EPR/CSPE to indenter modulus data with respect to accelerated aging temperature and time.

**References**

1. D. E. McCabe, R. K. Nanstad, S. K. Iskander, and R. L. Swain. 1994. "Unirradiated Material Properties of Midland Weld WF-70," NUREG/CR-6249 (ORNL/TM-12777).
2. P.M. Scott and P. Combrade, 2019. "General corrosion and stress corrosion cracking of Alloy 600 in light water reactor primary coolants," Journal of Nuclear Materials 524: 340-375.
3. S. M. Bruemmer, M. J. Olszta, et al., "Linking Grain Boundary Microstructure to Stress Corrosion Cracking of Cold-Rolled Alloy 690 in Pressurized Water Reactor Primary Water," Corrosion 69 (10), 2012, p. 953-963.
4. M. B. Toloczko and Z. Zhai, "SCC Initiation Testing 2017 Report," PNNL-27011, October 2017.
5. Z. Zhai, M. B. Toloczko, and S. M. Bruemmer, "Stress corrosion crack initiation behavior of Alloy 600 and Alloy 690 in PWR primary water." PNNL technical milestone report M2LW-18OR0402034, Light Water Reactor Sustainability Program, September 2018.
6. L. Tan, B.A. Pint, "Steam oxidation of alloy 718A and tensile properties of select advanced replacement alloys for LWR core internals," ORNL/TM-2019/1308, September 13, 2019.
7. X. Chen, L. Tan, "Fracture toughness evaluation of select advanced replacement alloys for LWR core internals," ORNL/TM-2017/377, August 25, 2017.
8. L. Tan, T. Chen, B.A. Pint, "Steam oxidation behavior of Ni-base superalloys 690, 725 and X-750 at 600 and 650°C," Corros. Sci. 157 (2019) 487-497.

## Physical Security

**P**hysical security of nuclear power plants is important to maintaining a safe, secure, and reliable domestic nuclear energy fleet. Implementation of enhanced physical security requirements at U.S. nuclear power plants after September 11, 2001, resulted in larger onsite physical security forces and costs that are comparatively high to other operational costs. Continuously staffing each physical security post at a nuclear utility site requires about five armed responders. The LWRS Program conducts research in a number of areas to improve efficiencies and optimize costs to ensure physical security at commercial nuclear power plants.

In 2019, the Physical Security Pathway engaged with stakeholders such as nuclear utilities, the Electric Power Research Institute (EPRI), the Nuclear Regulatory Commission (NRC), the Nuclear Energy Institute (NEI), and vendors to identify the technical challenges that should be addressed to optimize current approaches to physical security. The Physical Security Pathway identified the following *preliminary* needs: (1) continue and broaden stakeholder engagement to better define problems and identify opportunities to affect them through R&D efforts, (2) enhance physical security modeling and simulation tools, and (3) develop methods and tools to support approaches to risk-informed plant physical security.

The following sections summarize accomplishments in these areas. Physical Security Pathway accomplishments can be found on the LWRS Program website (<https://lwrs.inl.gov>).

### Stakeholder Engagement

Stakeholder engagement is a key component of the LWRS Program because it allows the program and its R&D pathways to engage with industry stakeholders to identify needs and gaps in capabilities to meet those needs, methods to develop the appropriate technical bases for proposed enhancements, and potential partners for collaborative R&D projects—i.e., pilot projects. The Physical Security Pathway actively engaged industry by (1) inviting utilities to a physical security training course held in March 2019, (2) visiting utility sites to review their physical security systems, security plans, and identify areas of desired improvements, and (3) holding Physical Security Stakeholder Working Group meetings.

The Physical Security Stakeholder Working Group comprises nuclear enterprise physical security stakeholders, and the meeting included more than 10 utilities representing roughly 65 nuclear power plants, NRC, NEI, EPRI, physical security vendors, and LWRS Program researchers at Sandia National Laboratories (SNL) and Idaho National Laboratory (INL).

Participants of the working group provided significant input into the direction of the Physical Security Pathway that includes (1) research into advanced technology focused on the application of security technologies that could result in force multipliers, (2) risk-informed physical security research to address the technical basis gaps required to optimize physical security, and (3) development of a security cost model that can be used to identify the economic impact of changes to physical security elements.

Future working group meetings will be held to continue to engage stakeholders with periodic updates. These meetings also provide input and information to inform the development of ongoing R&D planning and assist in prioritizing activities and plan future engagement activities.

### **Enhancement of Physical Security Modeling and Simulation Tools**

Analysis tools used by the physical security industry provide needed capabilities for security users. Each tool produces some of the information needed by stakeholders to make decisions related to their physical security postures. Stakeholders and decision makers typically need a variety of tools and must integrate the results themselves to support their needs. Each tool employs assumptions, and they may collectively have unexamined gaps that remain unanalyzed. For example, the effects to a nuclear plant that result from sabotaging systems can be similar to the effects of an external event (e.g., earthquake, fire, flood, etc.). These are events already postulated in existing plant PRAs. These events typically assume widespread damage to the plant due to the occurrence and to the surrounding environs. This assumption is reasonable in its original safety context, but in a physical security event, damage occurs when caused by an adversary and may result in different consequences to the plant (e.g., the consequences may selectively target key systems or affect them differently than typical failure modes to produce widespread damage).

Current industry practices in physical security assessments employ “target sets” for a plant and use security-modeling tools to analyze the timelines and effectiveness of a given security posture (i.e., physical security elements and the typical means for their use) against a defined adversary. Modeling is an approach used to evaluate the security posture’s effectiveness in preventing an adversary from reaching a target set. Integrating physical protection analyses with tools that analyze the response of reactor systems allows for modeling the actual nuclear and radiological consequences of an attack, including the timeline from the start of an attack to a consequence of concern.

In 2019, LWRS Program researchers studied ways to integrate modeling and simulation tools to help stakeholders improve the technical basis for making physical security decisions with the intent of optimizing physical security postures and realizing associated O&M cost benefits. The tools studied included: Lone Pine Nuclear Power Plant (LPNPP) model [1], Scribe3D [2], ADAPT [3], MELCOR [4], and Event Modeling Risk Assessment using Linked Diagrams (EMRALD) [5]. The LPNPP model serves as a hypothetical reactor with known security vulnerabilities and can serve as a public testbed for evaluating various security modeling tools. Scribe3D is a force-on-force (FoF) security code that can simulate adversary attacks on facilities. MELCOR is a reactor-physics-based response model that provides radiological consequences for various nuclear reactors. MELCOR is a deterministic model that has been used with ADAPT, a dynamic event-tree driver, to quantify uncertainties. EMRALD is a dynamic PRA tool that incorporates other physics-based tools to explore plant response. Utilization of tools like these in a security scenario allows analysts to understand the physical consequences related to a physical attack and the timelines associated with the response models. These advanced, integrated tools allow for analysts to evaluate a much-broader state space than the current security tools and could enable mitigations not currently used.

Work in 2019 has shown promise as the work in integrating physical and safety models below illustrates. This work will be continued in 2020.

### **Lone Pine Nuclear Power Plant—Integrated Security and Reactor System Response Modeling**

To better integrate existing physical security tools, software tools must include the appropriate elements of plant-state representation and physical security response beginning at the point of an initial adversary intrusion through the consequences of concern posed by the target set. Information should be transferred between these tools to facilitate complete analysis of relevant physical security and plant response parameters dynamically across a range of postulated scenarios. Researchers identified that a combination of tools—including the LPNPP model, Scribe3D, ADAPT, and MELCOR—would be able to achieve this goal.

Several security scenarios were created based on the conventional target-set methodology. For these scenarios, current approaches to physical security analysis has determined that sabotage of the target sets would result in the postulated consequences to the facility. From these scenarios, a loss of ultimate heat sink was selected for analysis through an integrated security (using Scribe3D) and safety (using MELCOR) analysis by using the ADAPT dynamic event-tree framework. This preliminary analysis has shown some promise in assessing the effects of sabotage on target sets with the onset of reactor core damage.

In preparation for this integration effort, LWRS Program researchers developed these codes and tools to improve their integrated analysis capabilities. During 2019, LWRS Program researchers updated the LPNPP facility layout, constructed a LPNPP model in Scribe3D, upgraded Scribe3D to accept input from ADAPT, and used target sets to develop security scenarios for analysis. This work leverages an existing hypothetical example used for international physical security training: the LPNPP facility model, with predetermined target sets for vulnerability-assessment modeling. The ultimate goal of this work is to develop a more-realistic basis for modeling and simulations of an existing nuclear power plant's security regime for use in understanding the impact of attack to the actual consequences.

The LPNPP facility is a fictional, but representative, two-loop PWR with a reactor power level of 1,150 MW<sub>e</sub> at full power that has been used for over a decade in international security-training courses. This high-fidelity nuclear power plant model is used as a surrogate for actual nuclear power plant site models, allowing researchers to evaluate the results in a realistic environment. The system consists of a reactor, a closed primary-coolant loop connected to the reactor vessel, and a closed separate power-conversion system (e.g., secondary coolant) for the generation of steam to power turbines. Cooling water to the main condenser is provided from a river. Since the LPNPP is a fictional facility, there are known vulnerabilities and gaps within the physical-protection strategy that allow it to be used as an open-source facility for modeling. A model of the LPNPP was constructed in Scribe3D for security modeling and, during the modeling effort, the reactor core was replaced with a version more suitable for safety analysis using the MELCOR tool. Also, a flexible equipment (FLEX) building was added to include the modeling of operator actions outside the main



Figure 46. LPNPP facility layout.

control room into the security analyses. Figure 46 shows the current overall LPNPP site layout and details of the various buildings within the generic nuclear power plant model. This is the current model used in the Scribe3D software and will be used where appropriate for future LWRS physical security modeling, reactor-system response modeling, and table-top exercises. Sites integrating these tools would use the model of their individual sites instead of the LPNPP model. The standalone structure to the left of Figure 46 is the added FLEX building.

Scribe3D is a software tool that can provide integrated security-safety modeling. It is a three-dimensional (3D) scenario-simulation tool that was developed to analyze scenario attack planning, execution, analysis, playback, and table-top support. Figure 47 shows a typical screenshot from Scribe3D as it is used as a tabletop



Figure 47. Scribe3D main view for a tabletop exercise.

exercise tool to display adversary and defender timelines. It is user-friendly and allows users to add physical security elements, such as personnel and vehicles, to a 3D environment that can then be used to develop realistic, high-fidelity scenarios, and play those scenarios back from different visual angles and speeds. Scribe3D is equipped with a combat calculator and detection system for realistic engagements, air and ground vehicle simulators for better movement timelines, and modifiable effects such as fire, explosions, and plumes. It also has the capability to run Monte-Carlo simulations on scenarios developed by a single-analyst or from a table-top exercise. Its high-quality visualizations and flexibility allow it to support myriad different exercises, events, and security evaluations.

Scribe3D was not originally intended to integrate with dynamic tools like ADAPT, which performs job scheduling and dynamically controls uncertainties in scenarios. Scribe3D scenarios did not originally permit modification by external tools like MELCOR. LWRs research added capabilities to Scribe3D to run a simulation from the command line and a text data file. This additional data file contains the coupling for ADAPT scheduling with the Scribe3D and MELCOR, and will enable the execution of large high-throughput calculations on a diverse array of computing clusters. This coupling will permit high-resolution exploration and study of important uncertainties in safety-security scenarios. In 2019, researchers completed the foundation for coupling the LPNPP, Scribe3D [2], and ADAPT to MELCOR [6]. This, and subsequent proof-of-concept of real-time linking of uncertain safety and security scenario data, resulted in dynamic event-tree analysis. It will significantly improve the capabilities available to physical security users to more realistically analyze potential scenarios and their physical security elements, which will allow them to make informed decisions on protective strategies and remove unnecessary conservatisms that exist in physical security postures without impacting security effectiveness. Removing these conservatisms could potentially have a significant reduction in security O&M costs by reducing the need for security posture elements.

### **Dynamic Risk-Informed Research for Plant Physical Security Regimes**

Measures of quantitative effectiveness are needed to evaluate current defensive measures employed by commercial nuclear power facilities. To form a robust risk-informed methodology, evaluations of effectiveness must include information about test results beyond whether a subject facility passed or failed portions of physical security assessments. Currently, site inspections and FoF evaluation methods produce limited data that can be used by the involved facility or be made available for other facilities. Because the initiating event for security-related scenarios is due to a person or group intending to circumvent protective measures and induce damage, traditional risk tools used by the nuclear industry and others do not work well to characterize the factors that are traditionally considered in risk assessments.

A potential adversary in physical security assessments has a plan and a goal they intend to achieve. They may create failures that traditional system analyses and



failure-analysis methodologies do not typically consider. For example, an adversary may damage several independent systems in a plant simultaneously by actions that normally do not have a common-cause failure mechanism via mechanical, electrical, or other deterministic means.

Advances in computational capabilities, algorithms, and methods have produced dynamic assessment tools that may be used to analyze these types of hazards. Research in this area is intended to demonstrate how dynamic analysis tools can improve the realism in characterizing and analyzing postulated physical security events. This will improve the ability to develop measures of quantitative effectiveness that can improve physical security methods and approaches. This should reduce some of the conservatism that exists in physical security plans that were implemented without the benefit of applicable data and may help optimize plant physical security plans. This is intended to improve the realism and reduce conservatisms in the technical bases for physical security postures, thereby reducing plant operating costs while maintaining required physical plant protection.

Results in 2019 have shown promise as the work in dynamic-assessment models below illustrates. This work will be continued in 2020.

### **Dynamic Assessment Models for Plant Physical Security Regimes**

Dynamic-assessment models research develops tools and techniques to allow nuclear power plants to evaluate proposed changes to their physical security postures. Regulations require that changes made to the physical security plan implement new strategies that are as effective as the current ones. Nuclear power plants often resist making cost-savings changes to their physical security posture because there are no clear methods for evaluating and demonstrating the effectiveness of alternative postures. The results of this research will enable plants to identify options to reduce the cost of physical security by providing modeling tools and techniques for quantitatively evaluating the effectiveness of alternative security postures.

Two main tools exist to effectively analyze a system's ability to meet a set of requirements: (1) real-world testing and (2) modeling and simulation. While real-world testing is often seen as more accurate, it also has its limitations: cost and accurate threat representation and reproduction. With the increase in computational capabilities and tools, modeling and simulation complement and can replace or vastly reduce physical testing. Modeling can also provide accurate statistical results and the ability to modify more parameters of threat scenarios. Systems that are time-dependent or have interactive failure mechanisms and components require dynamic modeling. Modeling and simulation tools are developed to improve the representation of dynamic aspects of postulated physical security events and improve the effectiveness of physical security response. While these tools may not be used to replace physical FoF exercises entirely, they provide a powerful means to both optionally reduce FoF exercises

and verify equivalent protection to support changes to protection design, equipment, or strategy.

Researchers in this effort are using EMERALD, a dynamic risk-assessment tool that can couple with other simulation or physics tools in developing a methodology for coupling FoF simulation with operator and personnel actions, plant models, and secondary factors such as FLEX portable equipment [7]. EMERALD is a state-diagram modeling tool based on three-phase discrete-event simulation, where the next events in time are sampled. This allows for fast runtimes with either close, long, or bunched spacing of events in time. A user interface allows for quick and easy-to-understand modeling of scenarios and system, component, and operator actions.

During 2019, LWRS Program researchers integrated several FoF simulation tools in the EMERALD application, including a commonly used commercial application and a DOE-developed application, Scribe3D. Figure 48 shows the Scribe3D model of the LPNPP facility, plant physical security layout, and hypothetical-adversary



**Figure 48. Sliced view of the LPNPP facility in Scribe3D.**

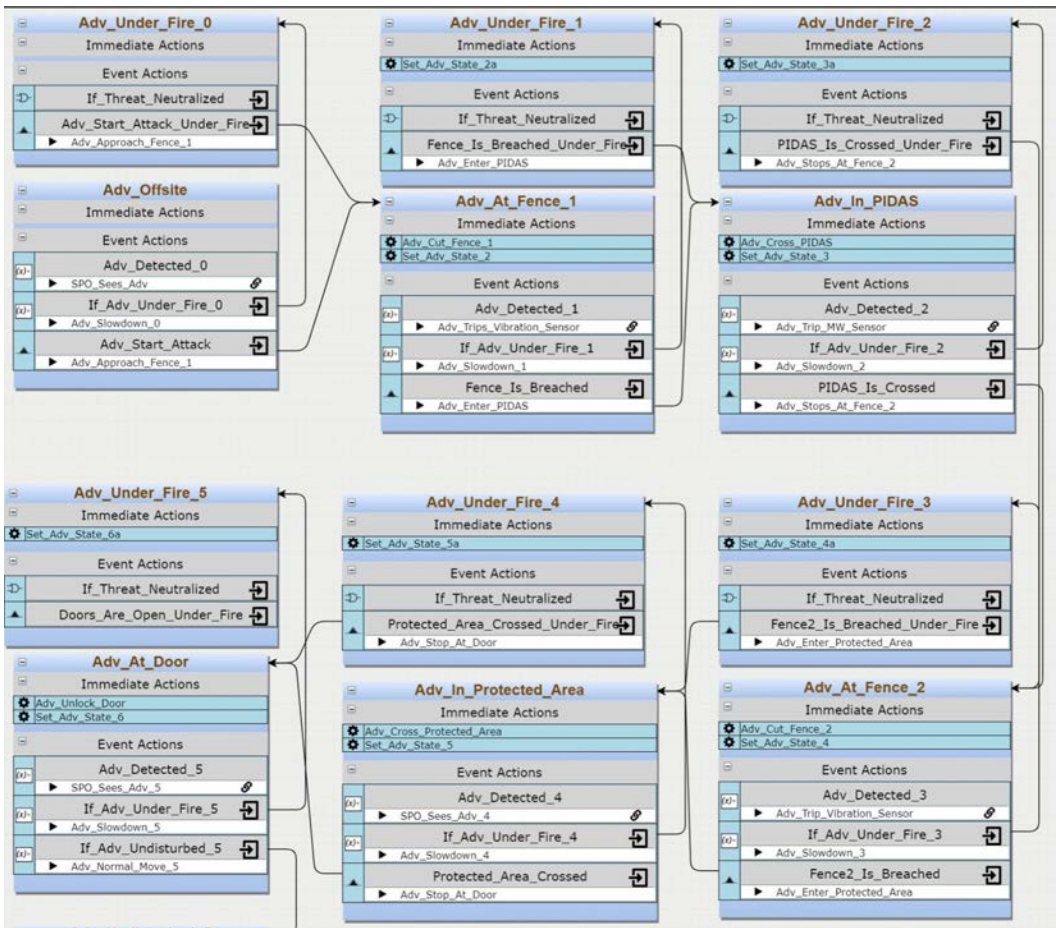


Figure 49. Different states in the attack scenario modeled in EMRALD.

starting locations. Figure 49 shows a notional diagram that is produced by this tool to represent some of the possible outcomes of physical security scenarios modeled with the EMRALD tool.

This research effort integrated the FoF models in the Scribe3D computer simulation tool with the dynamic modeling and assessment tool EMRALD. EMRALD employed Monte Carlo simulations that ranged from several hundred thousand to a million simulation runs that varied statistical parameters of adversary behavior and facility response in the attack scenarios modeled. Each Monte-Carlo simulation was run using a unique value for the different randomly varying parameters, such as adversary timeline, responder timeline, outcome of an engagement, etc. The results obtained from simulation provide quantitative measures of the effectiveness of different elements of a plant’s physical security in mitigating the attack.

The initial evaluation of these modeling efforts and a description of the development, findings, and analysis of dynamic models of current and potential physical security posture at a typical U.S. commercial nuclear power plant are documented in Ref. [9]. These FoF models provide a means to quantitatively assess a plant's physical security effectiveness in an attack scenario. The models enable the researchers to analyze current posture, identify strength and weaknesses, explore different strategies, and support identification of potential optimizations in a plant's physical security posture. The modeling and simulation capability achieved by integrating FoF with EMERALD dynamic models enabled modeling of dynamic scenarios during an attack and incorporate statistical simulation of input variables to provide quantitative results. Current FoF models do not have the capability to account for operator actions or FLEX equipment uses or to perform optimization of variables automatically. Integration of other risk applications with the FoF modelling through EMERALD will provide a method to assess and adopt more-efficient physical security postures to reduce costs. The modeling capability developed in this effort is being used to develop risk-informed, quantitative assessments of physical security for use by industry stakeholders.

Future dynamic modeling effort in this research will involve integrating EMERALD with existing FoF models of a partnering nuclear power plant and incorporating increased realism in modeling, analysis and outcomes.

### References

1. SNL, "Lone Pine Nuclear Power Plant (LPNPP) hypothetical facility exercise data handbook," 1 September 2017 [Online]. Available at: [https://share-ng.sandia.gov/itc/assets/hypo\\_fac\\_lpnpp\\_090117.pdf](https://share-ng.sandia.gov/itc/assets/hypo_fac_lpnpp_090117.pdf). [Accessed 1 September 2019].
2. SNL, "Scribe3D User's Manual" SAND2019-13848, Sandia National Laboratories, Albuquerque, NM, USA.
3. Z. Jankovsky, T. Haskin, and M. Denman, "How to ADAPT," SAND2018-6660, Sandia National Laboratories, Albuquerque, NM, USA.
4. L. Humphries, B. Beeny, F. Gelbard, D. Louie, and J. Phillips, "MELCOR Computer Code Manuals Vol. 1: Primer and Users' Guide," SAND2018-13559 O, Sandia National Laboratories, Albuquerque, NM, USA.
5. INL, "EMERALD," [Online]. Available at: <https://emerald.inl.gov/SitePages/Overview.aspx>. [Accessed 1 September 2019].
6. D. Osborn, M. Parks, R. Knudsen, K. Ross, C. Faucett, T. Haskin, P. Kitsos, T. Noel, and B. Cohn, "Modeling for Existing Nuclear Power Plant Security Regime" SAND2019-12015, Sandia National Laboratories, Albuquerque, NM, USA.
7. NEI, "Guidance for Optimizing the Use of Portable Equipment (NEI 16-08)," NEI, Washington DC, 2017.
8. T. Noel, T. Le, E. Parks, and S. Stromberg, "Scribe3D-Tabletop Recorder v. 1.1," US-DOE, 22 August 2018 [Online]. Available at: <https://www.osti.gov/doi/biblio/16918>. [Accessed 6 September 2019].

9. V. Yadav, S. Prescott, J. Buttles, J. Weathersby, M. Holbrook, R. Boring, D. Osborn and J. Hanson, "Current Challenges, Constraints and Recommendations for Reducing Cost of Physical Security at U.S. Commercial Nuclear Power Plants," INL/EXT-19-54452, Idaho National Laboratory, Idaho Falls, ID, USA.

## PROGRAM CONTACTS

---

### Program Management



**Alison Hahn**

Federal Program Manager  
Office of Nuclear Energy  
U.S. Department of Energy  
alison.hahn@nuclear.energy.gov  
(301) 903-5049

### Technical Integration Office



**Bruce P. Hallbert**

Director  
Idaho National Laboratory  
bruce.hallbert@inl.gov  
(208) 526-9867



**Cathy J. Barnard**

Operations Manager  
Idaho National Laboratory  
cathy.barnard@inl.gov  
(208) 526-0382



## Research and Development Pathway Leads



### Plant Modernization

**Craig A. Primer**  
Idaho National Laboratory  
craig.primer@inl.gov  
(208) 526-8376



### Flexible Plant Operation and Generation

**Richard D. Boardman**  
Idaho National Laboratory  
richard.boardman@inl.gov  
(208) 526-3083



### Risk-informed Systems Analysis

**Curtis L. Smith (Acting Lead)**  
Idaho National Laboratory  
curtis.smith@inl.gov  
(208) 526-9804



### Materials Research

**Thomas (Tom) M. Rosseel**  
Oak Ridge National Laboratory  
rosseeltm@ornl.gov  
(865) 574-5380



### Physical Security

**F. Mitch McCrory**  
Sandia National Laboratories  
fmmccro@sandia.gov  
(505) 845-3031



***On December 5, 2019, NRC staff approved Florida Power & Light's application to renew its licenses for its Turkey Point Nuclear Units 3 and 4 allowing the utility to operate the units until 2052 and 2053, respectively. This is the first time the NRC has issued renewed licenses authorizing reactor operation from 60 to 80 years. This marks an important planned milestone in the history of commercial nuclear power operations in the U.S.—one that underscores the long-term dependability of these plant designs and the commitment to their long-term performance by the organizations that operate them. The LWRS Program works with owner-operators to address key issues needed to support the technical bases for continued safe long-term operation of our nation's nuclear power assets.***



[lwrs.inl.gov](http://lwrs.inl.gov)