

**LWRS**



LIGHT WATER REACTOR  
SUSTAINABILITY

Overview and Accomplishments

# Sustaining National Nuclear Interests



U. S. DEPARTMENT OF  
**ENERGY**



Overview and Accomplishments

# Sustaining National Nuclear Interests



---

LIGHT WATER REACTOR SUSTAINABILITY

## From the LWRS Program Technical Integration Office Director



**Bruce Hallbert, Director, LWRS  
Program Technical Integration  
Office.**

The Department of Energy's Office of Nuclear Energy (NE) recently issued its Strategic Vision. The Strategic Vision identified five goals.

1. Enable continued operation of existing U.S. nuclear reactors
2. Enable deployment of advanced nuclear reactors
3. Develop advanced nuclear fuel cycles
4. Maintain U.S. leadership in nuclear energy
5. Enable a high-performing organization

The Light Water Reactor Sustainability (LWRS) Program is the primary programmatic activity that addresses NE's first goal.

The LWRS Program, sponsored by the U.S. Department of Energy and coordinated through a variety of mechanisms and interactions with industry, vendors, suppliers, regulatory agencies, and other industry research and development (R&D) organizations, conducts research to develop technologies and other solutions to improve economics and reliability, sustain safety, and extend the operation of the nation's fleet of nuclear power plants.

The LWRS program has two objectives to maintain the long-term operations of the existing fleet:

1. to provide industry with science and technology-based solutions to implement technology that can exceed the performance of the current business model; and
2. to manage the aging of systems, structures, and components (SSCs) so nuclear power plant lifetimes can be extended and the plants can continue to operate safely, efficiently, and economically.

The LWRS Program carries out its mission to accomplish the following objectives:

- Enhance the economic competitiveness of operating light water reactors in current and future energy markets, and;
- Ensure the performance of structures, systems, and components.

The LWRS Program, in close collaboration and cooperation with industry, provides technical foundations for the continued operation of the nation's nuclear power plants using the unique capabilities of the national laboratory system.

This report provides an overview of the LWRS Program and recent select accomplishments that directly support the objectives of the LWRS Program.

**Federal Program Management**



**Alison Hahn**  
Federal Program Manager  
Office of Nuclear Energy  
U.S. Department of Energy  
alison.hahn@nuclear.energy.gov



**Sue Lesica**  
Materials Research Federal Lead  
Office of Nuclear Energy  
U.S. Department of Energy  
sue.lesica@nuclear.energy.gov



**Jason Marcinkoski**  
Flexible Plant Operation and Generation  
Federal Lead  
Office of Nuclear Energy  
U.S. Department of Energy  
jason.marcinkoski@nuclear.energy.gov

**Technical Integration Office**



**Bruce P. Hallbert**  
Director  
Idaho National Laboratory  
bruce.hallbert@inl.gov



**Cathy J. Barnard**  
Operations Manager  
Idaho National Laboratory  
cathy.barnard@inl.gov

**Research and Development Pathway Leads**



**Craig A. Primer**  
Plant Modernization  
Idaho National Laboratory  
craig.primer@inl.gov



**Richard D. Boardman**  
Flexible Plant Operation and Generation  
Idaho National Laboratory  
richard.boardman@inl.gov



**Svetlana (Lana) Lawrence**  
Risk-Informed Systems Analysis  
Idaho National Laboratory  
svetlana.lawrence@inl.gov



**Thomas (Tom) Rosseel**  
Materials Research  
Oak Ridge National Laboratory  
rosseeltm@ornl.gov



**Douglas M. Osborn**  
Physical Security  
Sandia National Laboratories  
dosborn@sandia.gov

**Contents**

**Overview** ..... 6

**Sustaining the Existing Fleet**..... 12

*Enhancing the Economic Competitiveness of the Existing Fleet*

- Research to Reduce Operating Costs and Improve Efficiencies to Enhance Economic Competitiveness..... 12
- Research to Enable Diversification of Revenue and Expand to Markets Beyond Electricity ..... 26

*Delivering the Scientific Basis for Continued Safe Operation*

- Understanding and Managing the Aging and Performance of Key Materials for Long Term Operation..... 33
- Addressing Aging and Obsolescence of Plant Technologies ..... 38

## Light Water Reactor Sustainability Program

### 1. Overview

**N**uclear energy is an important contributor to meeting national electricity-generation objectives. It provides reliable baseload capacity at historically high availability rates while supporting national greenhouse-gas emission goals. The United States (U.S.) commercial nuclear power industry has demonstrated a substantial history of safe operation and serves as a vital element that ensures the stability of the nation's electricity grids.

Electric power is a vital component of the nation's economy and is essential to continuing improvements in the quality of life. Nuclear energy is the nation's largest contributor of electric-power generation that does not emit greenhouse gases and other air pollutants (i.e., carbon dioxide, methane, nitrous oxide, and fluorinated gases), comprising 55% of non-emitting sources in 2019 (see Figure 1). Operation of the nation's nuclear power fleet avoided 476 million metric tons of carbon dioxide emissions in the U.S. compared to fossil energy sources<sup>1</sup> and is a vital element of achieving climate goals to reduce carbon dioxide emissions.

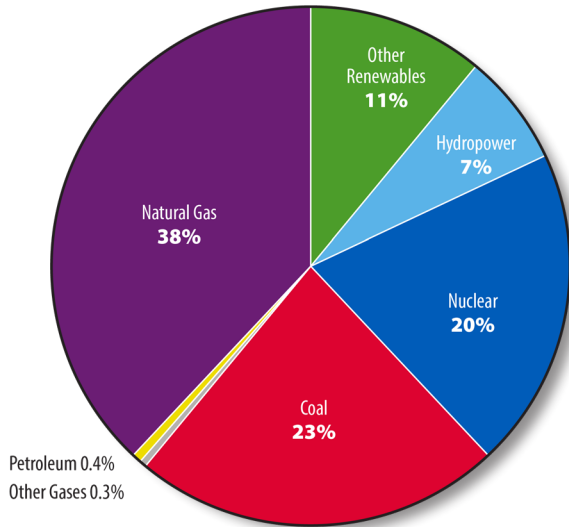
Other forms of low carbon dioxide-emitting and renewable energy production methods (e.g., hydroelectric, wind, geothermal, solar) have the potential to produce substantial energy, though some of these sources are, by their nature, intermittent and of limited use for baseload power until energy storage becomes economical. With the projected increase in the contribution of intermittent renewable energy sources (i.e., wind and solar) to the U.S. domestic electric capacity<sup>2</sup>, the reliability and availability of nuclear energy is key to ensuring the nation's electricity supply.

Nuclear power also provides the following needed capabilities for energy and national security:

- **Fuel source diversity:** An appropriate balance of more than one type of energy resource within the electricity supply system is prudent to mitigate short-term scarcity and price volatility
- **Electric supply reliability:** An electrical-power supply in the U.S. must be dependable and have an adequate capacity margin to support industrial and residential needs during periods of varying demand, both seasonally and daily
- **Environmental sustainability:** This includes minimal free-release emissions, no carbon dioxide emissions, small environmental footprint, and minimal solid waste
- **National security:** In order to have a major role in setting international standards for safeguards, security, and safety, the U.S. must be a major player in domestic nuclear energy to influence the directions taken worldwide. Nuclear energy and its domestic supply chain are also vitally important to ensuring a capacity needed for U.S. national security and related infrastructure.

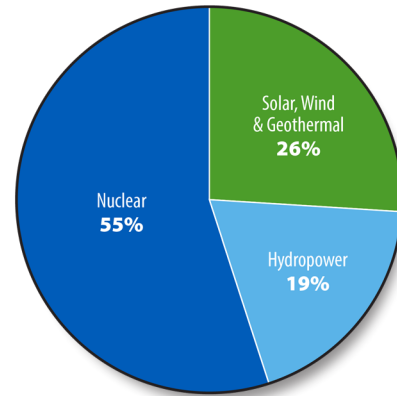
Nuclear power plants are important to many communities and to the nation's economy. The economic impacts of operating nuclear power plants greatly benefit surrounding areas. The Nuclear Energy Institute (NEI, 2015) found that a typical nuclear plant generates approximately \$470 million in sales of goods and

**Energy sources and percent share of total for electricity generation in 2019**



Source: <http://www.eia.gov/tools/faqs/faq.cfm?id=427&t=3>

**Sources of emission-free electricity**



Source: <https://www.energy.gov/ne/downloads/us-emissions-free-electricity-generation-share-source-2019>

21-50005-01

services and nearly \$40 million annually in high-paying jobs. Premature closures of commercial nuclear plants affect the economic activity in surrounding areas leading to higher electricity prices<sup>3</sup>, more carbon emissions<sup>4,5</sup>, and reductions in local municipal operating budgets that rely on the tax revenues from an operating nuclear power plant<sup>6</sup>. The Brattle Group<sup>7</sup> estimates that the commercial nuclear industry produces 475,000 jobs and contributes \$60 billion annually to the U.S. Gross domestic product.

In January 2013, 104 nuclear power plants operated in 31 states. However, since that time, eight plants have been shut down (several due to economics), with additional shutdowns announced to occur by 2021 and other nuclear units identified as being at risk of closure due to economics and market policies<sup>8</sup>. The current environment of inexpensive, abundant natural gas and subsidized renewable energy sources was a major factor in the most recent and planned shutdown decisions due to economics. This current situation has significantly increased emphasis on reducing the costs of producing energy from commercial nuclear sources. The Nuclear Energy Institute (NEI) is leading efforts within the industry through an initiative called “Delivering the Nuclear Promise,”<sup>9</sup> to maintain focus on safety and reliability, improve the efficiency of operating nuclear power plants, and ensure monetary recognition of nuclear energy’s value. Because of the clear and continuing economic challenges faced by nuclear power plants, the LWRS Program focuses many of its research and development (R&D) efforts on improving the economic performance of light-water reactors (LWRs) in current and future energy markets.

Unless second license renewals are granted, decommissioning of the current fleet of nuclear power plants will begin near the year 2030. Early (i.e., prior to 60 years of

**Figure 1. U.S. electricity-generation portfolio in 2019, showing dominance of nuclear as a low-carbon-emission power source.**

operation) shutdowns due to economic factors will increase this shortfall. Hence, the continued safe and economical operation of current plants to and beyond the current license limit of 60 years is an important option for supplying needed electricity and maintaining the existing level of emission-free power generation capability at a fraction of the cost of building new plants.

To receive a 20-year license extension, a nuclear power plant operator must ensure the plant will operate safely for the duration of the license extension. The 40-year initial operating-license period established in the Atomic Energy Act was based on antitrust and capital-depreciation considerations, not technical limitations. The 20-year license-extension periods are presently authorized under the governing regulation of 10 Code of Federal Regulations (CFR) Part 54, "Requirements for Renewal of Operating Licenses for Nuclear Power Plants."<sup>10</sup> This rule places no limit on the number of times a plant can be granted a 20-year license renewal. This regulatory process ensures that licensed nuclear power plants can continue to be operated safely and efficiently during future renewal periods.

Since 2007, DOE and its national laboratories together with industry and other stakeholders, have conducted efforts through the LWRS Program to sustain operations of the U.S. LWR fleet. The aim of these efforts is to execute an R&D strategy and activities that address nuclear-energy issues within the framework of the National Energy Policy and the National Energy Policy Act of 2005.

The LWRS Program, in close collaboration and cooperation with industry provides technical foundations for the continued operation of the nation's nuclear power plants, utilizing the unique capabilities of the national laboratory system. This involves engaging national laboratory facilities, staff, and expertise to conduct research needed to inform decisions, demonstrate technical solutions, and provide methods needed for the long-term management and operation of nuclear power systems. Government and industry cost-sharing and involvement promotes advances in needed capabilities that are of crucial long-term, strategic importance to sustaining the existing LWR fleet. The LWRS Program, by incorporating collaborative industry stakeholder inputs and shared costs, supports the strategic national interest of maintaining nuclear power as an available resource.

Decisions on second license renewal and required investments to support long-term operation are made by plant owners. On December 5, 2019, U.S. Nuclear Regulatory Commission (NRC) staff approved Florida Power & Light's application to renew its licenses for its Turkey Point Nuclear Units 3 and 4, allowing the utility to operate the units until 2052 and 2053, respectively. This is the first time the NRC has issued renewed licenses authorizing reactor operation from 60 to 80 years. Other utilities, such as the Dominion Generation Group, Exelon Corporation, Duke Energy, and NextEra have also submitted applications for their operating reactors or indicated their intention to seek second license renewals for their fleet.

The technical results from the LWRS Program provide data, methods, and technologies that are used by owner-operators and the regulator to make informed decisions and take actions needed to ensure the continued operation of the existing U.S. LWR fleet. Through the variety of R&D activities carried out together with and used by industry, the LWRS Program reduces key uncertainties and risks that many owner-operators face regarding the long-term performance



of vital materials, plant modernization, efficiency improvement, and other issues needed to make the investments required for nuclear power plant operation periods to and beyond 60 years.

### 1.1 Research to Enable Sustainability

Sustainability, in the context of this program, is the ability to maintain safe and economic operation of the existing fleet of nuclear power plants for as long as possible and practical. It has two facets with respect to long-term operations: (1) to provide industry with science-based solutions to implement technology that can exceed the performance of the current business model; and (2) to manage the aging of plant systems, structures, and components (SSCs) so that nuclear power plant lifetimes can be extended, and the plants can continue to operate safely, efficiently, and economically. The goals of the R&D activities conducted by this program are to ensure or enable operating nuclear power plants to be economically competitive within their energy markets and to proactively address aging and obsolescence of plant SSCs, and technologies.

The LWRs Program carries out its mission through a set of five R&D pathways that are summarized below:

- **Plant Modernization:** R&D to address nuclear power plant economic viability in current and future energy markets through innovation, efficiency gains, and business-model transformation through digital technologies. The goals of these activities are to enable broad modernization of the existing LWR fleet to enable extended plant operations and to transform the nuclear power plant operating model through application of digital technologies to enable cost reductions and economic sustainability.
- **Flexible Plant Operation and Generation:** R&D to evaluate economic opportunities, technical methods, and licensing needs for light water reactors to directly supply energy to industrial processes. The goals of these efforts are to support the development and deployment of technologies for diversification of products and revenue from plant operations.
- **Risk-Informed Systems Analysis:** R&D to optimize safety margins and minimize uncertainties to achieve high levels of safety and economic efficiencies. The goals of these activities are to develop and deploy risk-informed technologies for use by industry to enable more cost-effective plant operations.
- **Materials Research:** R&D to develop the scientific basis for understanding the long-term environmental degradation behavior and develop technologies for their mitigation in key materials in nuclear power plants. The goals of these activities are to provide the technical basis for the continued safe operation of the existing fleet for extended periods and to develop technologies to mitigate the effects of environmental degradation on key materials.
- **Physical Security:** R&D to develop and enhance methods, tools, and technologies that advance the technical basis needed to optimize and modernize a nuclear facility's security posture. The goals of these activities are to develop and deploy advanced technologies and provide the technical basis for optimizing physical security costs and activities at nuclear power plants.

The Technical program plans for each of these pathways are produced and updated annually and will be made available through the web site for this program (see <https://lwrs.inl.gov>). Progress is being achieved in each of these areas, and a number of outcomes from these efforts are summarized in the performance indicators in Table 1-1 below.

**Table 1-1. Performance Indicators to Enable the Continued Operation of Existing U.S. Nuclear Reactors.**

Performance Indicators
1. By 2022, demonstrate a scalable hydrogen generation pilot plant.
2. By 2023, demonstrate a technical basis for the deployment of advanced technologies to enhance physical securities at operating plants.
3. By 2023, demonstrate and support development of advanced risk analysis and simulation tools to enable plants to improve operations, reduce operating costs, and enhance existing safety features at operating plants.
4. By 2024, demonstrate the use of Integrated Operation Methods to achieve plant operating cost reductions by \$5/MWh.
5. By 2026, complete engineering and licensing activities needed to demonstrate successful deployment of a digital reactor safety system in an operating plant.

## 1.2 Program Research and Development Interfaces

Planning, execution, and implementation of the LWRS Program are done in coordination with the nuclear industry, NRC, universities, and related DOE R&D programs to assure relevance, efficiency, and effective management of the work. Coordination with both industry and the NRC are needed to ensure a uniform approach, shared objectives, and efficient integration of collaborative work for the LWRS Program.

### 1.2.1 Industry

The LWRS Program works with industry on nuclear-energy-supply technology R&D needs of common interest. The interactions with industry are broad and include cooperation, coordination, and direct cost-sharing activities. The guiding concepts for working with industry are leveraging limited resources through cost-shared R&D, direct work on issues related to the long-term operation of nuclear power plants and the need to focus government-sponsored R&D on the higher-risk and/or longer-term projects.

The Electric Power Research Institute (EPRI) has established programs that are complementary to activities of the DOE LWRS Program. EPRI and industry's interests include applications of scientific understanding and tools to achieve safe and economical long-term operation of the current LWR fleet. The interface between DOE-NE and EPRI is defined in a memorandum of understanding.<sup>11</sup>

### 1.2.2 Nuclear Regulatory Commission

The NRC employs a memorandum of understanding<sup>12</sup> with DOE that specifically allows for collaboration on research supporting the long-term operation of nuclear power

plants. Fundamental data and technical information obtained through joint research activities are of interest and useful to each agency. Accordingly, to conserve resources and avoid duplication of effort, it is in the best interest of both parties to cooperate and share data and technical information and, in some cases, the costs related to such research, whenever such cooperation and cost sharing may be done in a mutually beneficial fashion.

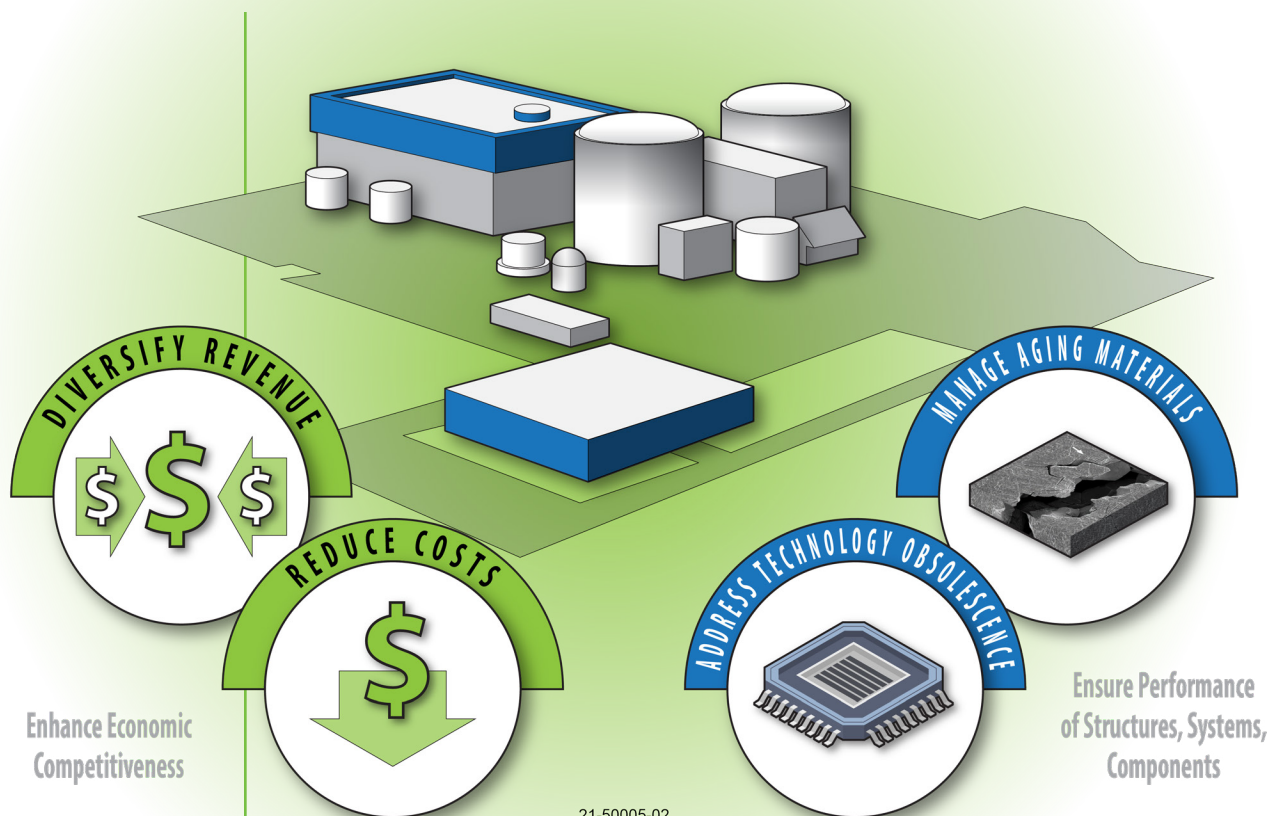
### 1.2.3 International

DOE coordinates LWRS Program activities with several international organizations with similar interests and R&D programs. The LWRS Program continues to develop relationships with international partners, including the following international organizations, to maintain awareness of emerging issues and their scientific solutions:

- Organization for Economic Co-operation and Development
  - **Halden Project:** The Halden Project is a jointly financed R&D program under the Nuclear Energy Agency (NEA) of the Organization for Economic Co-operation and Development (OECD).
  - **Working Groups of the NEA:** The OECD forms committees and working groups within NEA to assist member countries in maintaining and further developing the scientific and technical knowledge base required to address current issues related to nuclear reactors and fuel-cycle facilities.
- **International Atomic Energy Agency (IAEA) Plant Life Management:** IAEA is the world's center of cooperation in the nuclear field and works with its member states and multiple partners worldwide to promote safe, secure, and peaceful nuclear technologies.
- **Bilateral Activities:** There are several U.S. bilateral activities underway (e.g., U.S.-Argentina, U.S.-Japan, U.S.-India, U.S.-Canada) that include activities specific to the LWRS Program. These bilateral activities provide an opportunity to leverage work ongoing in other countries.

### 1.2.4 Universities

Universities participate in the LWRS Program in at least two ways: (1) through awards made by DOE from the Nuclear Energy University Program (NEUP); and (2) via direct contracts with the national laboratories that lead the directed R&D activities of the LWRS Program. NEUP funds nuclear-energy research and infrastructure upgrades at U.S. colleges and universities and provides scholarships and fellowships to students (see <https://neup.inl.gov>).



**Figure 2. Paths to sustaining the existing fleet of light water reactors through collaborative research and development.**

## 2. Sustaining the Existing Fleet

The LWRS Program focuses its research activities on two objectives needed to sustain the existing operating fleet in current and future energy markets (Figure 2). Efforts to enhance the economic competitiveness of the existing fleet are being accomplished through research that aims to reduce the operating costs of nuclear power plants and diversify the sources of revenue available to generate income by expanding to markets beyond electricity supply. Efforts to ensure the performance of systems, structures, and components is being achieved through research to understand and mitigate the effects of environmental conditions on materials and to address the obsolescence of aging plant technologies. The programmatic activities and selected recent accomplishments toward these objectives are described in Sections 2.1 and 2.2.

### 2.1 Enhancing the Economic Competitiveness of the Existing Fleet

#### 2.1.1 Research to Reduce Operating Costs and Improve Efficiencies to Enhance Economic Competitiveness

Many commercial nuclear power plants are facing increasing economic pressure arising from the historically low cost of natural gas and the correspondingly low operating costs of natural-gas combined-cycle power plants, combined with an increase in renewable-energy capacity (specifically solar and wind) on the power

grid. Although the nuclear power industry has achieved record plant availability and electricity production<sup>13</sup>, the prices of electricity in many domestic markets coupled with reduced electrical demand have forced some plants out of business. For many nuclear power plants to remain economically viable and competitive, they will need to address the long-term cost of operation by identifying or adopting approaches to reduce their operating costs while maintaining their high performance.

The LWRS Program's R&D activities enable nuclear power plants to enhance their efficiency and performance to reduce costs through a variety of projects that are carried out collaboratively with owner-operators, vendors, suppliers, and other research organizations. The Pathways of the LWRS Program each contribute to these outcomes through a variety of means.

Research is being conducted to enable widespread cost reduction and operational improvements. This research addresses critical gaps in technology development and deployment that are designed to reduce the risks and costs of substantial modernization efforts at operating nuclear power plants. The objective of these efforts is to develop, demonstrate, and support deployment of new digital instrumentation and control (I&C) technologies for process control, enhance worker performance, and provide enhanced monitoring capabilities.

This work has two strategic goals:

- To develop digital technologies and improve work processes that renews the technology base for extended operations beyond 60 years.
- To transform the nuclear power plant operating model through application of digital technologies to enable a new approach to operations that ensures long-term technical and economic sustainability.

#### ***2.1.1.1 Advanced Concept of Operations for Improved Cost and Performance***

Research is being conducted with owner-operators to develop and deploy an advanced concept of operations for existing nuclear power plants that employs restructuring plant processes and existing technologies to reduce operating costs using advanced technologies and a more technology-enabled staff. Critical to this approach are advanced digital technologies. The adoption of an advanced concept of operations will enable opportunities to restructure the nuclear power plant operating model in a manner that results in new and more efficient ways of working. The model for this, Integrated Operations for Nuclear (ION), uses a plant specific market analysis to identify goals for operation and management costs and a plant capacity factor

needed for long term commercial viability. Based upon results of these modeling and cost goals, a plant or organization-specific transformation strategy is developed to identify needed technology and process modifications, including goals for staffing and qualifications to achieve the targeted sustainability goals. Also provided are improved methods for achieving plant safety margins, reductions in unnecessary conservatisms, and approaches to best use expertise from across the nuclear enterprise.

**RESEARCH ACCOMPLISHMENT**



**Development of a new and transformative business process ecosystem, Integrated Operations for Nuclear (ION), that could reduce plant O&M costs by over 30%**

The objective of this research collaboration is to deliver a validated approach to the commercial nuclear power industry to bring operating costs in line with long term market expectations for sustainability and price competitiveness. The approach involves transforming the current operating model of work processes in plant operation—and to accomplish this through business-driven technology innovation. This addresses two required capabilities for extended plant life: long-term operation and economic viability.

Together with Xcel Energy Nuclear Generation, the LWRS Program has developed a business-driven approach to transforming the operating model of commercial nuclear power plants from labor-centric to technology-centric—just as many other industry sectors have done to remain competitive in today’s marketplace.

The Integrated Operations for Nuclear (ION) refers to the integration of people, disciplines, organizations, and work processes—supported by information and communication technology to achieve real-time integration of parallel functions employing multi-disciplinary teams, collaboratively connected across distances for enhanced execution of work (see Table 2-1). An example of this kind of business model transformation is found in the North Sea oil and gas companies that, over the past two decades, have implemented Integrated Operations (IO) to restructure their operating models to remain profitable amid declining offshore petroleum fields and depressed oil and gas prices. Using advanced digital technologies, they re-engineered approaches to modern oil field operations by transforming their operations and support functions to be

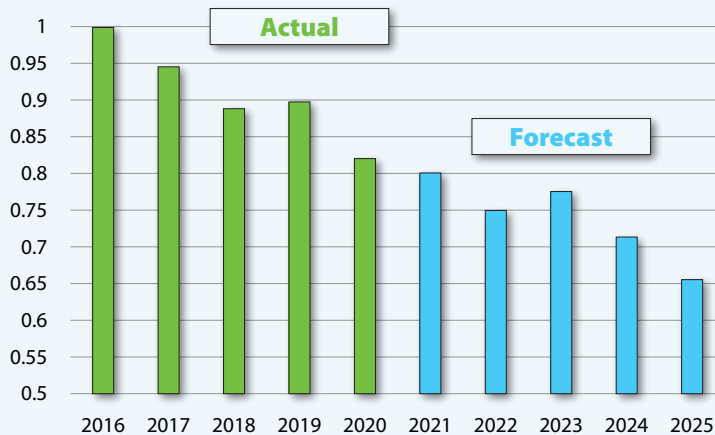
**Table 2-1. Traditional and Integrated Operations-enabled approaches to work processes.**

Traditional Work Processes	Integrated Operations Work Processes
Serial	Parallel
Single Discipline	Multi-Discipline
Dependence of Physical Location	Independent of Physical Location
Decisions made based on historical data	Decisions made based on real-time data
Reactive	Proactive

largely conducted onshore and serve multiple platforms simultaneously, to more fully integrate supplier functions with their own organizations to reduce long term costs, and to seamlessly integrate work processes and functions to directly support operations.

The LWRs Program team worked directly with Xcel Energy, Norway’s Institute for Energy Technology, and ScottMadden Associates to analyze nuclear generation work functions to derive more efficient means of accomplishing the required outcomes through work elimination, requirements reduction, process improvement, technology application, and other forms of innovation resulting in a projected long-term operations and maintenance (O&M) cost reductions of over 30%. This may yield long term costs savings on the order of hundreds of millions of dollars annually, depending on the scale of deployment and scope of improvements that are finally implemented. However, progress is already being made in achieving targeted cost reductions as shown in Figure 3, and progress toward the long-term cost performance goals are occurring through these efforts.

**Normalizing Operating Cost (\$/MW-hr)**



**Figure 3. Actual and Forecast costs of operations resulting from ION-based enhancements.**

The ION framework is a business-driven approach for transforming the operating model of a commercial nuclear plant from labor-centric to technology-centric, using a top-down/bottom-up process. This new business ecosystem shows promise as a model to guide the nuclear power industry in transforming to meet current and future challenges posed by the new economic realities of power generation.<sup>14</sup>

**2.1.1.2 Technologies and approaches to monitor plant components and materials**

In combination with research to enable business transformation, the LWRs Program and DOE are conducting and sponsoring research to enable key technology improvements needed to achieve long term business transformation and cost performance

improvements through technologies and approaches to monitoring and management of plant components and materials. The research relies on replacing existing approaches to manually conduct many surveillances, inspections, tests, and some types of maintenance with automated monitoring using advanced sensors, algorithms for monitoring system and component performance, and the development and deployment of data analytics to continuously ensure safe and efficient plant performance.

Funding awards to utilities, industrial partners, and national laboratories have resulted in several projects that are developing and demonstrating the means to automate many plant monitoring functions. One project was awarded to a team comprised of Public Services Enterprise & Group (PSE&G) Nuclear, PKMJ Technical Services LLC, and Idaho National laboratory who are developing and demonstrating a fully integrated, risk-informed, condition-based maintenance capability on an automated platform. When implemented, this capability will significantly reduce O&M costs associated with traditional time-based approaches to maintenance that has been historically employed in the commercial nuclear industry on plant equipment. A second project was awarded to Utilities Service Alliance, a consortium of operating nuclear utilities, to research, develop, and deploy automation and advanced remote monitoring technologies into the U.S. nuclear fleet to reduce O&M costs while improving safety and reliability. These projects will be completed in 2022 and the resulting technologies documented in publicly available reports, including the results of plant-specific implementations. These multi-year awards, exceeding \$17 million in combined DOE and non-DOE funding, and the underlying research to enable their success are demonstrating progress to reduce the overall O&M costs and improve efficiencies in plant operation.

## RESEARCH ACCOMPLISHMENT



### Integrated Risk-informed Condition-based Maintenance Capability and Automated Platform

Public Service Enterprise Group (PSEG) Nuclear, LLC, PKMJ Technical Services LLC, and Idaho National Laboratory are conducting research and development to enable the implementation of risk-informed, condition-based predictive maintenance strategies. This research is supported by the U.S. Department of Energy (DOE) Office of Nuclear Energy's (NE) through a competitively-selected industry-led award. The project has three goals:

**Goal 1:** Develop a risk-informed approach to optimize equipment maintenance frequency

**Goal 2:** Develop a risk-informed, condition-based maintenance approach

**Goal 3:** Develop and demonstrate a digital, automated platform to centralize monitoring technologies

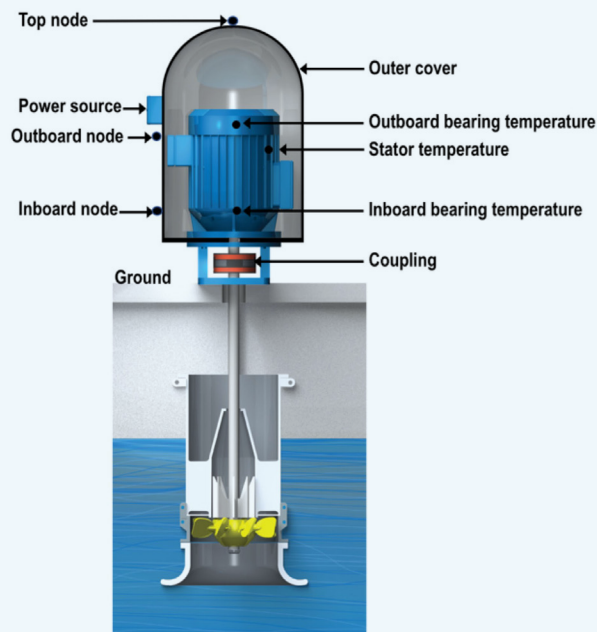
Achieving these goals will result in models and methods enabling implementation of a risk-informed predictive maintenance program at a nuclear power plant. The resulting capabilities will contribute to long-term safe and economical operation, automation, efficiency, and enhanced reliability of plant systems in nuclear power plants.



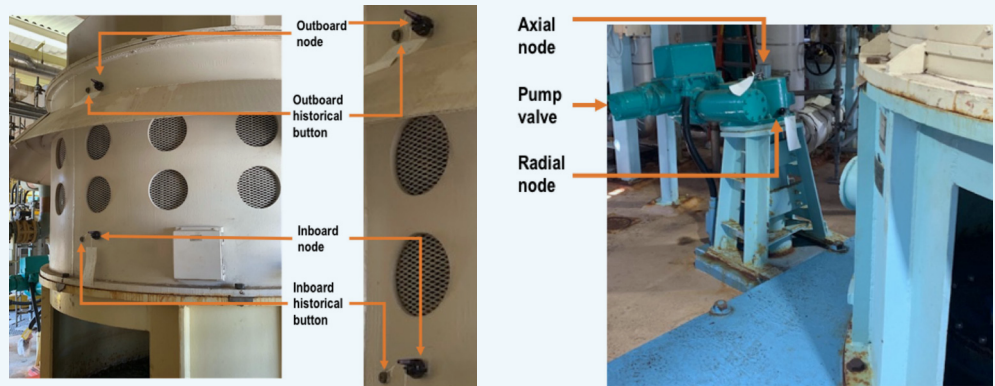
The major accomplishments achieved as part of fulfillment of Goal 1<sup>15</sup> include:

1. Design and implementation of the PKMJ digital platform in alignment with industry requirements<sup>16,17</sup>. This will provide guidance to nuclear power plants as they plan to develop or adapt a digital platform to their needs. The PKMJ digital platform is based on the Microsoft Azure Cloud Service. For advanced analytics, the Azure Databricks platform is used, enabling the flexibility to use multiple programming languages as needed.
2. Cost impact analysis and selection of a plant asset were performed by taking into consideration key factors such as location, sensor requirements, preventive maintenance (PM) schedules, and part availability and redundancy. Several plant assets at the Salem nuclear power plant were included in the analysis. The circulating water system (CWS) was selected as the target plant asset.
3. Wireless vibration sensor nodes (VSNs) were installed on the CWS at both units of the Salem nuclear power plant. This installation enables online vibration monitoring for predictive analytics and would eventually replace the periodic manual vibration measurement preventive maintenance activities. Sixty VSNs were installed across the 12-circulating water pump (CWP) motors and associated bypass valves (6 CWP per Unit). Each VSN consists of two accelerometers and a temperature sensor. The VSNs were mounted using a magnetic base at different locations as shown in Figures 4 and 5.
4. Advanced data analytics were used to transform raw data into useful insights. As a part of this effort, a convolution neural network-based natural language process classifier was developed to automatically classify work orders based on description. The model classified work orders into three categories: Failure, Degradation, or Others.

This effort aims to develop a model (Figure 6) that can accurately determine if the work order description identifies equipment failure, degradation of that equipment, or neither.

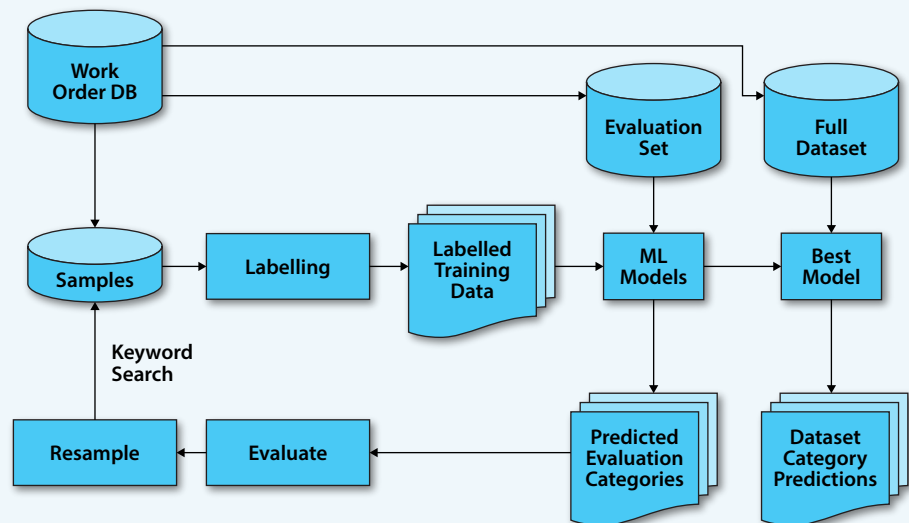


**Figure 4. Mounting location of the VSN on the CWP motor.**



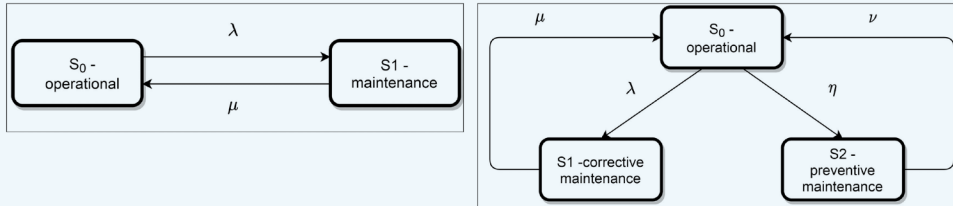
**Figure 5. VSN locations for CWP motors (left) and pump valves (right); VSNs are in close proximity to the locations where historical vibration data has been taken for CWP motors.**

5. Two-state and three-state Markov models (Figure 7) were developed by utilizing historical preventive and corrective maintenance events at the Salem nuclear power plant. The models provide insights in to the cost impact of current preventive and corrective maintenance strategies without taking into consideration of the condition of the CWP and CWP motor.
6. Preventive Maintenance Optimization (PMO) analysis, including potential savings, was performed, with resulting recommendations listed in Table 2-2. The analysis suggested that since there are changes to all 12 Pump/Motor PMs, the actual scheduled maintenance for PMs performed



**Figure 6. Work order classifier natural language process workflow.**

within the window will need to be re-baselined in order to level resource requirements. If implemented at the site, these changes could potentially result in a net savings of approximately \$4.37M over the next six years. This value was calculated using an assumed standard rate of \$75/man hour and approximated material costs.



**Figure 7. Two-state (left) and three-state (right) Markov models. Here  $\lambda$  is the failure rate;  $\mu$  is the corrective maintenance rate;  $\eta$  is the preventive maintenance scheduling rate; and  $\nu$  is the preventive maintenance rate.**

**Table 2-2. PMO recommended frequency.**

Equipment	Task Title	Current Frequency	Industry Average	Recommendation	Recommended Frequency
Pump	Refurbishment	6 years	14 Years	Less Frequent	9 Years
	External Visual Inspection	18/24 Months	2.8 Years	Keep	18 Months
Motor	Vibration Analysis	3 Months	5.5 Months	Less Frequent	6 Months
	Oil Analysis	6 Months	8 Months	Keep	6 Months
	Inspect/ Electrical Testing	3 Years	3 Years	Keep	3 Years
	Replace Motor	6 Years	10.7 Years	Less Frequent	9 Years
Motor Cable	VLF TAN-Delta Testing	6 Years	7 Years	Keep	6 Years
Protective Relays	Inspect/ Calibrate	6 Years	4 Years	Keep	6 Years
Pressure Switch	Calibration	4 years	4.2 Years	Keep	4 Years

Research to reduce operating costs also focuses on the optimization of plant safety margins and minimizing uncertainties to ensure both safety and economics are clearly understood. This can lead to new ways of meeting regulatory requirements while reducing costs. Safety is central to the design, licensing, operation, and economics of the U.S. LWR fleet. Plant designers have historically “over-designed” portions of plant systems which provided robustness in the form of redundant and diverse-engineered safety features. This form of defense-in-depth concept is a reasoned response to uncertainties and is often referred to generically as a safety margin.

Historically, specific safety margin provisions have been formulated primarily based on engineering judgment. Further, these historical safety margins have been conservatively established (for example in design and operational limits) to compensate for uncertainties. Safety is paramount for all activities and aspects of plant operation. Research employing risk-informed systems analysis is studying and demonstrating how to achieve safety more economically by using risk-informed approaches to plant operation, capital asset management, and by employing improved tools that reduce conservatism and uncertainties that are inherent in plant design.

Significant costs of plant operation, for example, stem from maintenance and testing, which are driven by regulatory and reliability requirements to ensure safe and continuous operation. Cost reductions may be achieved by optimizing plant safety analyses using plant dynamics, physical aging, and degradation processes in the safety analysis in a single consistent analysis framework.

### ***2.1.1.3 Cost and Risk Categorization Research to Enhance System Performance and Health Management***

The goal of Cost and Risk Categorization research is to leverage advanced computational capabilities to support enhanced system performance and health management. The first objective of this effort is to integrate various elements of system health monitoring, management, and reporting in a manner that is significantly less labor intensive and is technically effective. This is being addressed through research in plant health management. The second objective is to manage equipment and system performance and its financial risk and reduce costs associated with monitoring and regulatory compliance. This objective is being addressed through research conducted in a project on risk-informed asset management. These two projects are coordinated to achieve the goal of the Cost and Risk Categorization research and develop a software toolkit or platform which is referred to here as risk-informed plant system health.

The risk-informed plant system health platform is a model-based system engineering platform for system operations. Using system health data, this tool provides decision-making support to develop the best maintenance posture and an optimized component maintenance or replacement schedule. The maintenance posture is the maintenance strategy for each component that reduces O&M costs while maintaining adequate system availability.

**RESEARCH ACCOMPLISHMENT**



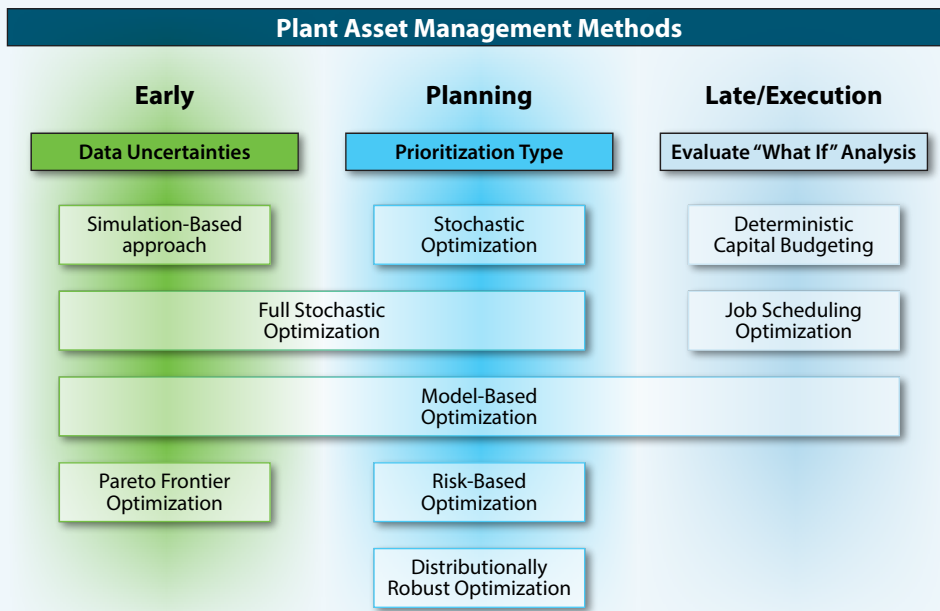
**Development of a Risk-Informed Asset Management Toolkit**

This research is developing and demonstrating methods to optimize plant operations and maintenance activities and decisions to achieve cost savings while satisfying safety and performance requirements, such as availability and reliability. The short-term cost savings are realized through an integrated Plant System Health program that maximizes automation and advanced data analytics to minimize cost and enhance performance. The long-term cost savings are achieved by implementation of a structured risk-informed approach to evaluate and prioritize plant capital investments made in preparation for and during the period of extended plant operation.

A variety of methods have been developed in the toolkit, both model-based and data-based. The model-based optimization methods are designed for very generic applications and apply both continuous and discrete methods. These optimization methods explicitly include reliability coupled with cost models to determine optimal plant operational strategy.

Data-based optimization methods target more specific use cases (e.g., project schedule optimization) and are not based on reliability models directly but require a specific dataset (e.g., component failure probability and its economic impact). These methods aim to determine the optimal project schedule that maximize the overall net present value. Depending on the available data or specific class of problem, the user can select the best-suited methods.

Figure 8 shows in a graphical form the classification of the methods being developed under the Risk-Informed Asset Management project.



**Figure 8. Overview of the developed optimization methods.**

Methods designed to identify optimal maintenance posture based on the Pareto frontier analysis have also been developed. Rather than performing a tradeoff analysis (i.e., identify the absolute best posture), these methods show how it is possible to perform a trade space exploration approach (i.e., identify value and costs of several postures and let the analysis impose desired value and cost constraints). This is performed by identifying maintenance postures that maximize value (e.g., system availability) and minimize operational costs.

The goal of this project is to manage equipment and system performance, their financial risk, and reduce costs associated with monitoring and regulatory compliance. The pilot projects planned in out-years will demonstrate how the goals are met, tangible benefits to the industry, and establish a deployment path that can be adopted by industry.

#### ***2.1.1.4 Margin Recovery and Operations Cost Reduction – Development of the Fire Probabilistic Risk Assessment software tool FRI3D***

Existing U.S. nuclear power plants are designed and constructed based on the defense-in-depth safety principle. Design basis safety analyses have been performed using deterministic approaches, which normally employ conservative models and assumptions to provide tolerances to account for uncertainties. The conservatism associated with the current design basis safety analysis process provide enough margin such that the probability of damage to the plant should be negligible even under the most severe plant conditions. The accumulation of these conservatisms may reflect unrealistic conditions that impose overly restrictive operating requirements limiting the operating flexibility of plants and adding costs.

Internal fire analyses for nuclear power plants are generally very conservative due to assumptions and simplifications employed in the evaluations. The Enhanced Fire Modeling project's goal is to recover safety margin and reduce costs by reducing conservatisms in current methods of analyzing fire risk and applying their results to plant operations. While the existing fire modeling process is effective to conservatively represent fire risks, more accurate modeling quickly becomes very time consuming and maintaining or updating the model for plant modifications can be very expensive. The goal of developing a new software toolkit for fire probabilistic risk assessment (PRA), called FRI3D (which is an acronym for Fire Risk Investigation in 3D), is to integrate the key aspects of fire PRA modeling into a single easy-to-use platform.

The primary goal of this project is to develop affordable software that will provide realistic insights by reducing unnecessary conservatisms in fire PRA models used by the nuclear operating fleet. The FRI3D software tool is a set of codes and PRA tools under development through this research that will address these needs. In the long term, this software's Application Program Interface (API) will provide the back end for advanced time-dependent fire analysis research.

## Enhanced Fire PRA Modeling Toolkit applied to industry scenario modeling

The objective of fire PRA model enhancement is threefold: (1) Reduce the amount of effort spent on day-to-day fire PRA tasks; (2) Economically reduce conservatisms of current fire PRA models by combining existing fire logic models, spatial information, and physics simulation tools; and (3) Analyze uncertainties in fire data used for plant modeling to identify data improvements that can reduce modeling conservatisms.

This research has advanced from a purely R&D stage into a demonstration and implementation phase where the potential for margin recovery and cost savings are being evaluated for operating plants that have implemented a risk-informed methodology for its fire hazard analyses (i.e., NFPA-805 plants). The FRI3D software tool (Figure 9) is a user-friendly application built to compliment and advance existing fire analyses. The tool has the following benefits:

- Enhances existing logic fire models with 3D spatial information;
- Eliminates all hand calculations and transferring of results from secondary application, saving time and reducing errors;
- Automatically performs the best analysis option for data available;
- Visualization of consequences for modeled scenarios;
- Understand timing and cause of failures (to inspire solutions);
- Performs “What if” calculations in seconds.

## RESEARCH ACCOMPLISHMENT

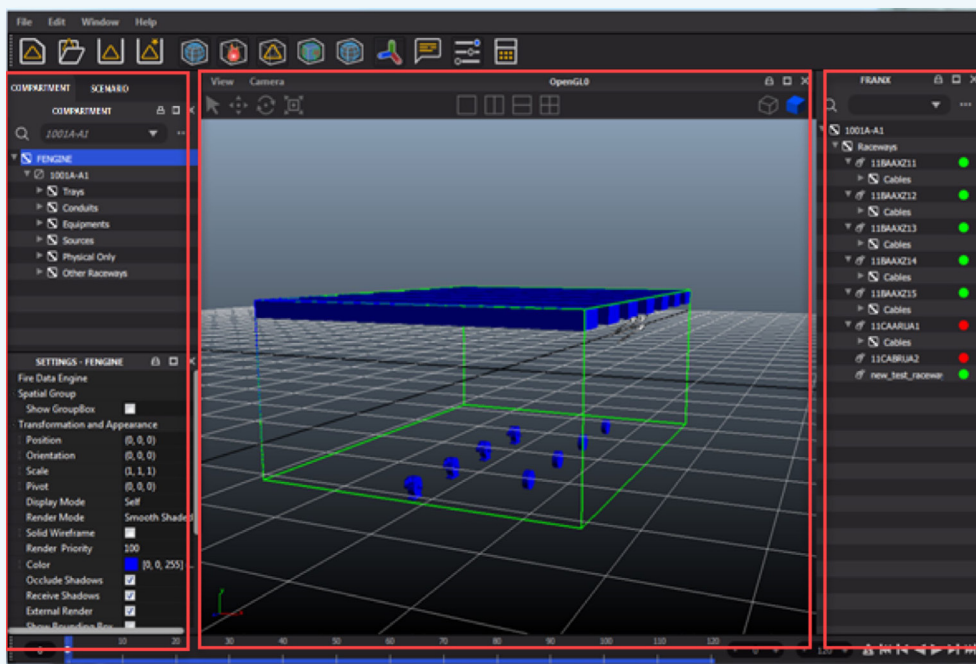


Figure 9. FRI3D GUI for developing and modifying scenarios.

The FRI3D Graphical User Interface (GUI) provides the ability to visualize spatial relationships of the objects. In addition, the GUI is designed to build and show links between the fire logical model and physical relationships in the plant (Figure 9).

Over the next two years, the LWR Program plans to advance this tool and ready it for industry use to serve as an integrated platform for all stages of fire analysis and operations use. A small business grant has been awarded to continue the commercial development of this software platform to Centroid LAB.

To support its use and deployment by industry, LWR Program researchers are actively engaged with industry collaborators to obtain feedback on industry needs and uses of the software platform to improve capabilities and potential enhancements of the FRI3D tools.

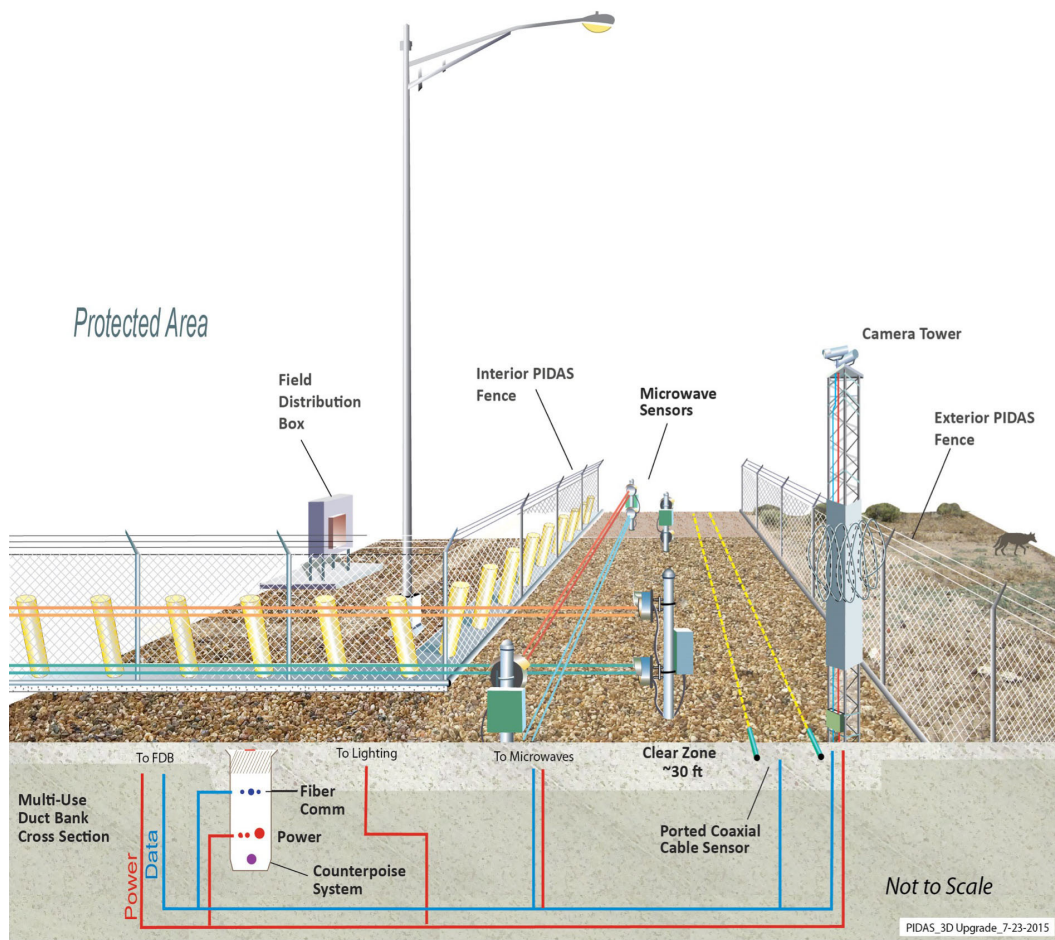
#### ***2.1.1.5 Advanced Technologies for Physical Security***

R&D efforts by the LWR Program also aim to enhance the cost effectiveness of plant operations through efforts in the Physical Security research. Physical security of nuclear power plant sites is an important aspect of maintaining a safe, secure, and reliable nuclear energy fleet. Physical security programs at U.S. nuclear sites (government and commercial) grew to meet changes in their design-basis threat over time and especially after the events of September 11, 2001. The need for U.S. nuclear power plant sites to maintain a large onsite physical security force ranks high in comparison to other plant operational costs. Figure 10 provides an example of the current security technologies used for a nuclear power plant site within the perimeter intrusion detection and assessment system (PIDAS), which can cost \$20,000 to \$100,000 per foot for installation at such a high security facility. The goal of near-term efforts is to enable the fleet to operate more closely to the security staffing requirements established in 10CFR73.55.

As domestic nuclear power plants modernize their infrastructure and control systems, an opportunity exists to apply advanced tools, methods, technology, and automation to optimize physical security postures and risk-inform their security regime. These include higher-fidelity models that reduce conservatisms in security models, leverage technology and automation as a force multiplier, and use advances in risk-informed methods to optimize security postures.

The objectives of this activity are to develop and deploy technologies to enable the commercial LWR fleet to adopt advanced security technologies. These R&D efforts will assist the LWR fleet in addressing the challenges in optimizing their physical security within a near-term (2 to 5-year) timeframe. Current efforts focus on incorporating the use of remote operated weapon system (ROWS) into the physical security posture at commercial nuclear power plants. The application of advanced security technologies into LWR physical security postures potentially provides significant force multipliers for the industry and may enable an optimized physical security posture without negatively impacting required physical security capability.



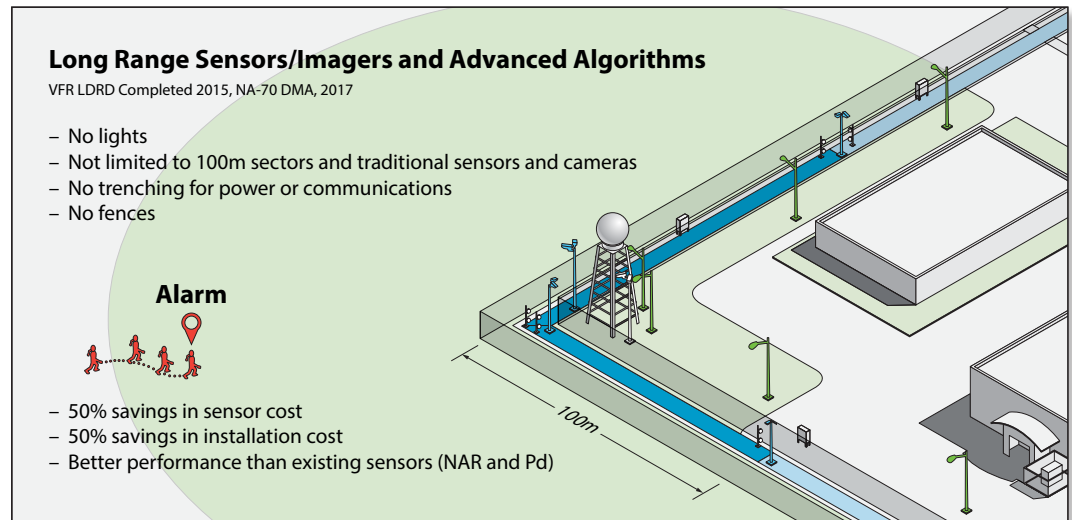


**Figure 10. Example of current PIDAS technologies at a nuclear power plant site for adversary detection and assessment entering the protected area.**

As a result of this research, efforts are underway with several operating nuclear power plants to adapt the technical bases for a ROWS system developed through this research to a plant-specific application that will be used to support a decision on use of this research in the final design and use for a deployment.

#### **2.1.1.6 Advanced Sensors for Physical Security**

The objective of these activities is to develop advanced sensors for physical security, which have the potential to significantly improve industry response time to a design-basis threat adversary early in the attack phase. Successful efforts in this area would increase the likelihood of defending against an attack and enhance the economics of doing so. This work will leverage technology to develop such advanced sensing capability as those shown in Figure 11. It provides a notional improvement beyond the PIDAS through advancement in U.S. Government developed security technologies that could be leveraged by the U.S. nuclear power sites to assist in overall cost reductions, reduced nuisance alarm rates (NAR) and increases in adversary probability of detection (Pd). Such a deployment of advanced sensor technologies will also increase the site's early response, increase the probability of interdiction, increase the probability of neutralization of an adversary, and raise the overall physical security system effectiveness.



**Figure 11. Example of U.S. Government technologies that could be leveraged at a nuclear power plant site for early adversary detection and assessment.**

### 2.1.2 Research to Enable Diversification of Revenue and Expand to Markets Beyond Electricity

The LWRS Program conducts R&D to use the full capacity of operating nuclear power plants to produce electricity that is transmitted to the electricity grid or by directing the thermal power and/or electricity produced by the nuclear power plant to an industrial customer either full-time or variably as electricity is dispatched to the grid. This research is referred to as Flexible Plant Operation and Generation. Flexible Plant Operation and Generation aims to maintain reactor and steam production at 100% power during periods of variable demand by the electric power grid – due to capacity or price related variation. This supports the use of energy from nuclear power plants even during periods of reduced electric grid demand, by enabling them to variably supply their energy to other industrial processes to generate other products from the clean energy of nuclear power plants.

The objective of this research is to enable nuclear power plants to diversify products beyond electricity for the life of the plants. This research provides insights into the benefits of nuclear energy beyond electricity. Research in this area emphasizes the evaluation of potential market opportunities for operating LWRs to supply energy or electricity to produce products beyond electricity, develop the technical systems approach to accomplish integration of these systems with an operating LWR, and to develop the methods and demonstrate their use in analyzing the safety of these transformed operations.

Research is conducted to develop and deploy concepts, systems, and facilities that use thermal and electrical energy produced from nuclear power plants to produce products beyond electricity to enable operating plants to remain economically viable in the evolving energy marketplace. Through the LWRS Program, individual utilities and plants are able to participate in these R&D projects and leverage the results for

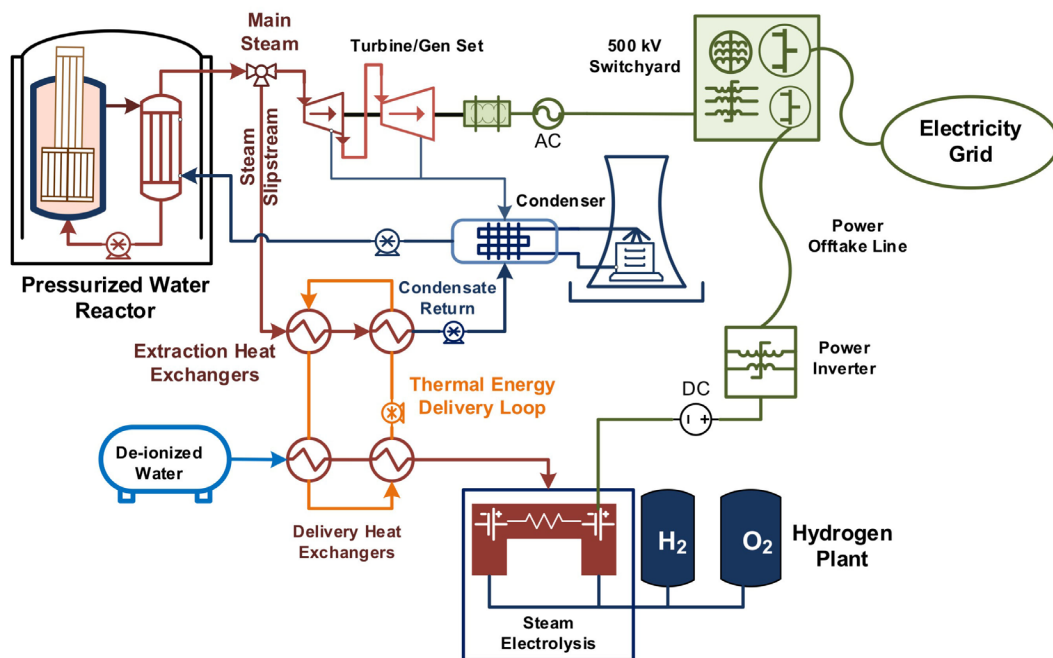
their benefit. The conceptual design of a hybrid flexibly operated plant producing other products such as hydrogen and grid electricity is shown in Figure 12.

**2.1.2.1 Deployment of scalable hydrogen generation at operating nuclear power plants to enable long-term diversification of products from energy production**

The LWRS Program and other DOE program offices are conducting and sponsoring research to support the demonstration and deployment of scalable hydrogen generation coupled to operating nuclear power plants. The LWRS Program research and awarded projects support collaborations with the commercial nuclear power industry to enable near term engineering, procurement, and deployment of these first-of-a-kind systems to demonstrate approaches to diversification of the uses of operating LWRs. These projects are the results of competitively selected awards by the DOE to operating nuclear companies, with partnerships from other utilities, vendors, suppliers, other research organizations, and national laboratories. An award in 2019 to Energy Harbor (successor company to First Energy Solutions Corporation) was made to develop a LWR hybrid energy system. The project will install a low temperature electrolysis (LTE) unit at the Davis-Besse Nuclear Power Station and funds efforts at other utilities and with national laboratories to evaluate the potential for hybrid energy systems in other markets. Major interfaces required for LWR hybrid operations (e.g., dynamic controls to apportion power output between the electrical grid and LTE unit) are addressed.

In a second project awarded in 2020, Northern States Power Company - Xcel Energy was selected to carry out planning, design, installation, testing, demonstration,

**Figure 12. Conceptual design of a hybrid Flexible Plant Operation and Generation plant producing hydrogen and grid electricity.**



and evaluation of non-electric, hybrid energy technologies connected to a LWR nuclear power plant. This project also involved participation by other utilities and national laboratories. The expected result of this project is to have both a fully functional hydrogen plant capable of operating as a hybrid system to test diverse electrolysis technologies coupled with a LWR and the design development for a hybrid reversible system. Both project deliverables are to be integrated into the normal operating routine of a nuclear power plant. These two awards represent over \$25 million in DOE and non-DOE funds to support the near-term deployment of hybrid energy systems to demonstrate scalable hydrogen production at operating commercial nuclear power plants.

Both of these projects build upon a third award made by the Office of Nuclear Energy and the Office of Energy Efficiency and Renewable Energy to Exelon Corporation to demonstrate a low temperature electrolysis system at one of their sites for on-site uses.

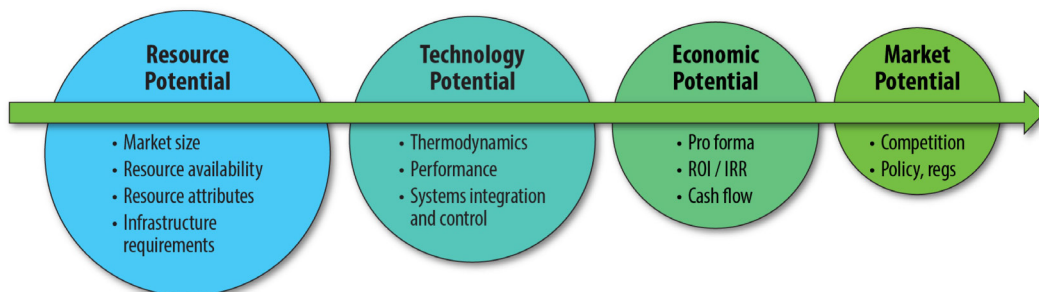
**2.1.2.2 Technical and Economic Studies to Support the Development and Deployment of Hybrid Energy Systems at Commercial Nuclear Power Plants**

The approach to evaluating the value proposition for LWR Flexible Plant Operation and Generation applications follows a graded approach. Beginning in Fiscal Years 2019 and 2020, market analyses identified those industrial markets that are growing, and therefore provide an opportunity for new manufacturing plant construction.

Given the rapidly growing interest in clean hydrogen, technical and economic assessments focused on the potential to produce and sell hydrogen in local markets. Research has also evaluated the plastics and polymers markets and opportunities for synthetic fuels production. Thermal energy use by industry has also been evaluated when considering industries (which consumes about one-third of the energy used in industrially developed countries), is divided into steam and electricity duties and process heating duties. Results of studies show that LWRs are capable of supplying over 80% of industrial energy use in the U.S.

The potential for new projects is being evaluated using the process illustrated in Figure 13 where a progressive approach is used to identify the ultimate market potential.

**Figure 13. Graded approach to assessing market potential for Flexible Plant Operation and Generation applications in non-electrical product markets.**



### Establishing the Case for Non-Electricity Markets for Operating Light Water Reactors

LWRS Program researchers completed technical and economic assessments (TEAs) of new market opportunities for LWRs. In 2020, the value proposition for producing hydrogen, plastic polymers, and synthetic fuels was established by showing the technical feasibility of coupling nuclear plants to processes that are designed to maximize the use of the thermal energy and electricity power that are produced by LWRs. In addition, a survey of manufacturing thermal energy duties that can be met with the steam produced by LWRs was completed. Hydrogen production presents a unique opportunity because the size of the existing market is large and growing and because hydrogen can be produced near a nuclear power plant and distributed to end users. Currently, the domestic market for hydrogen is 10 million metric tons (10 MMt). The serviceable hydrogen consumption power is projected to increase up to ninefold (91 MMt) by 2050.<sup>18,19</sup> The LWRS Program’s TEAs have shown LWRs can safely produce competitively priced hydrogen with near zero life-cycle emissions of air pollutants and greenhouse gases as shown in Figure 14.<sup>20</sup> A single nuclear reactor can produce 250,000 Mt annually, at a capacity factor of

### RESEARCH ACCOMPLISHMENT

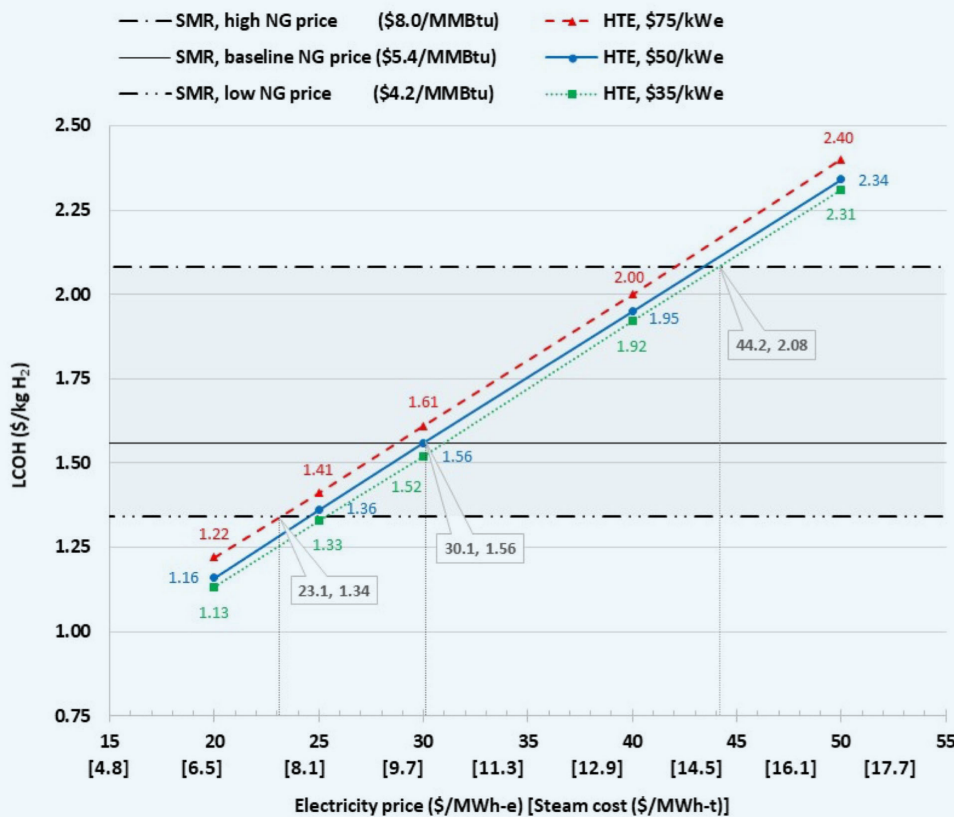


Figure 14. Comparison of hydrogen production costs for electrolysis versus conventional natural gas reforming.

over 95%. A twin-reactor plant could consistently produce this hydrogen with no interruption in supply.

A thorough safety and hazards review of a commercial-scale hydrogen plant located within 0.5 km of the nuclear plant, and an associated probabilistic risk assessment were completed and found amenable for obtaining an NRC license to dispatch energy to said plant.<sup>21</sup> Three separate processes were identified to approve a change in a LWR to send energy directly to an industrial process such as hydrogen production; 10 CFR 50.59 and RG 1.174 and a License Amendment Review through full 10 CFR 50.92 and Chapter 15 review.<sup>22</sup>

Similarly, a conceptual design of a new process for producing polyethylene – a feedstock for producing plastics and several valuable chemicals including antifreeze – was developed by LWRs Program researchers.<sup>23</sup> Based on a novel process in development, the study found an LWR plant could supply thermal and electrical power to an industrial-scale process resulting in a significant reduction in the cost of polyethylene production. This process further eliminates over 95% of the air pollutants produced by the conventional process which involves steam cracking of natural gas and crude oil derived molecules. The projected rise in demand for plastics could be met by shifting 8 to 10 nuclear power plants from generating electricity for the electrical grid to manufacturing polyethylene for consumer goods.

A study on clean synfuels production also verified this potential game-changing market is another non-electricity market for nuclear power plants. The study showed that the cost of producing motor gasoline and diesel fuels could be competitive with conventional petroleum refining when credits for avoiding CO<sub>2</sub> emissions are applied.<sup>24,28</sup>

The LWRs Program also completed a study on the thermal duties that can be met with LWR nuclear power plants.<sup>25,26</sup> The pulp and paper industries and minerals production industry are examples of industries that use copious amounts of steam that could be supplied by an LWRs. The challenge to these markets, however, is supplying steam over relatively long distances to the industrial plants. Therefore, a concept of future energy parks surrounding existing nuclear power plants was proposed. Such new plants would require expansion in these markets which likely would be incentivized with policies that reward low emission of pollutants. With nuclear power being considered clean energy, the value of current and potentially future clean fuels credits was summarized in a report.<sup>27</sup>

### ***2.1.2.3 Thermal-Electrical Energy Dispatch to Enable Hybrid Nuclear Plant Operations***

Close coupling of a nuclear power plant to an industrial user necessitates engineering design changes to the nuclear power plant to deliver thermal energy and/or electricity to the industrial user in a new manner. Every nuclear plant is unique beginning at the reactor core and continuing through the thermal hydraulic, power generation, and cooling systems. Each electricity transmission switch yard line up with the grid is also

unique. Consequently, plant design modifications will be required to tap any substantial amount of electricity or steam for Flexible Plant Operation and Generation applications.

Figure 15 shows a hybrid application where thermal energy and electricity are dispatched to a high temperature steam electrolysis plant. In this case, a slip stream of steam is extracted from the main steam lines ahead of the turbine generator. Condensate is returned to the plant condenser in a such manner that has the least impact on the thermal hydraulics lines in the power generation block and cooling water recirculation systems. However, both the nuclear power plant and the grid will be directly coupled to the operations of the steam electrolysis plant, even though the systems can be viewed as independent systems that can proportionally couple and decouple with the grid as a load- following plant. This will allow the nuclear plant to provide load-following power to the grid.

Current research by the LWRS Program to develop hybrid energy delivery systems employs nuclear power plant simulators to model and evaluate the performance of candidate hybrid energy systems and processes. The simulators are being coupled to thermal hydraulic computer models that are designed for delivery of thermal energy to close-coupled industrial users. These simulators are installed at the Human System Simulation Laboratory to identify and develop operating concepts for hybrid operations. The Human System Simulation Laboratory, in turn, is being tied to a representative thermal energy delivery system to validate the computer models and to demonstrate the technical feasibility of energy dispatch with representative physical processes.

#### **Development of a full scope pressurized water reactor simulator for evaluation of thermal energy dispatch to industrial users**

The key to flexible plant operations and generation is distribution of thermal energy to an industrial process in a dynamic manner. In 2020, the LWRS Program completed a preliminary design and proof of concept testing of a thermal power extraction system for a PWR. This effort was completed with support from expert nuclear plant engineers and operators. A full-scope Generic Pressurized Water Reactor (GPWR) simulator from GSE Systems was modified to incorporate a thermal power extraction system that apports steam from the main steam line to a bypass line that exchanges heat with a secondary heat transfer loop (Figure 15).<sup>28</sup>

A prototype human-system interface and supporting procedures were developed for simulation of thermal energy dispatch using the GPWR simulator for captured processes to warm the thermal power dispatch systems and initiate system operation to extract thermal power (see Figure 16). A preliminary proof of concept evaluation was then performed of thermal dispatch activities, using the prototype human-system interface, and prototype procedures.<sup>29</sup> Former licensed nuclear power plant operators participated in operator evaluation of the modified thermal power dispatch simulator, the prototype human-system interface, and the supporting procedures. The study confirmed elements of the design and approach for the prototype thermal power dispatch design and identified areas for future research and improvements.

#### **RESEARCH ACCOMPLISHMENT**



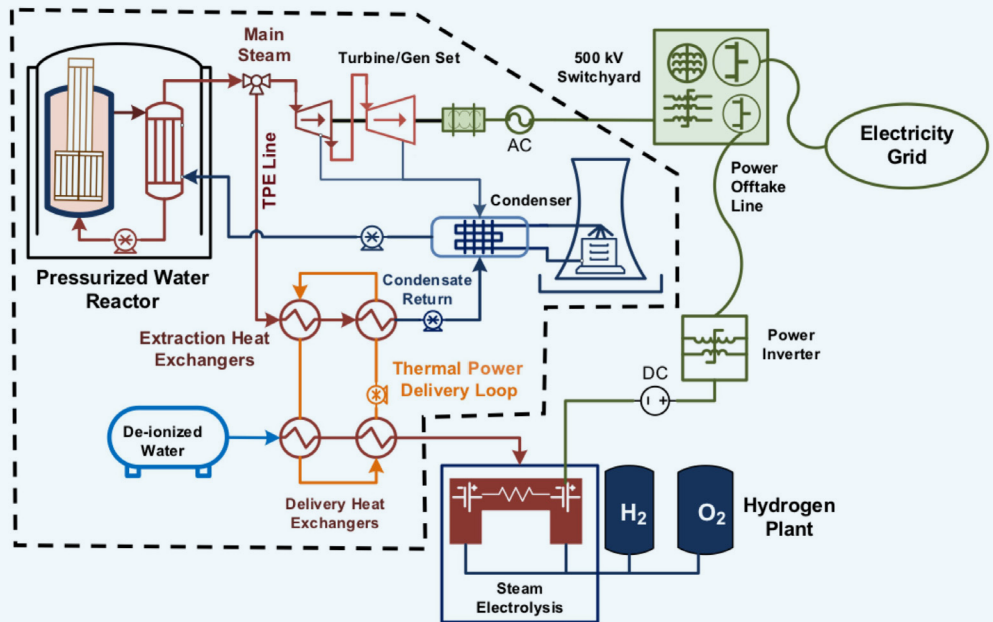


Figure 15. Boundary limits of the Thermal Power Dispatch GPWR Simulator (dashed line).

The GPWR simulator was also used to investigate the impacts of rapid thermal energy dispatch on core heat rate and power generation turbines, reheaters, and condensers to ensure thermal power extraction does not result in instabilities or thermal/mechanical stresses outside of current operating license basis when extracting up to 30% of the thermal power produced by a PWR. The outcomes of these studies were then used to complete a preliminary PRA for the combined thermal and electrical power delivery to a hydrogen plant.<sup>30</sup>

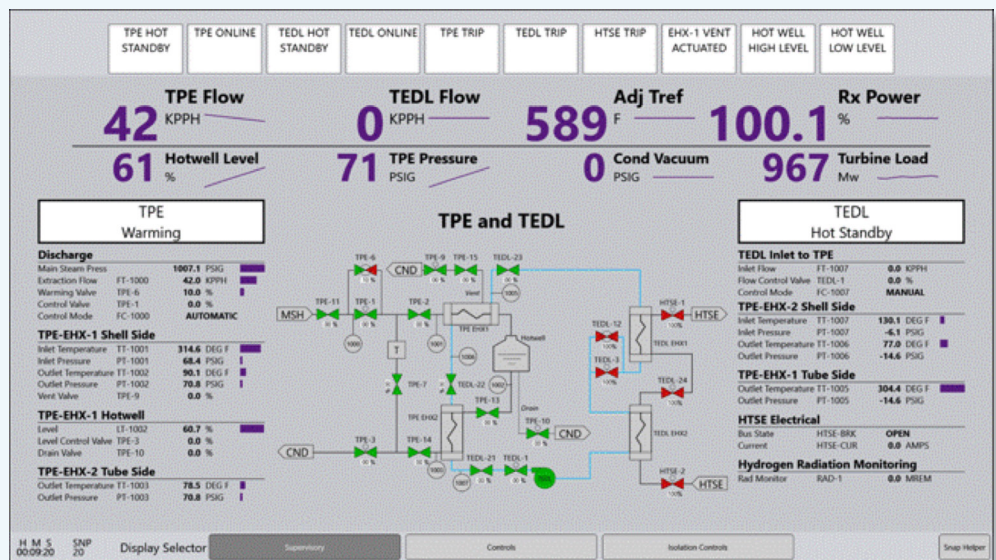


Figure 16. Human system interface design used for conducting human in the loop studies of operating a hybrid energy system integrated in a pressurized water reactor.



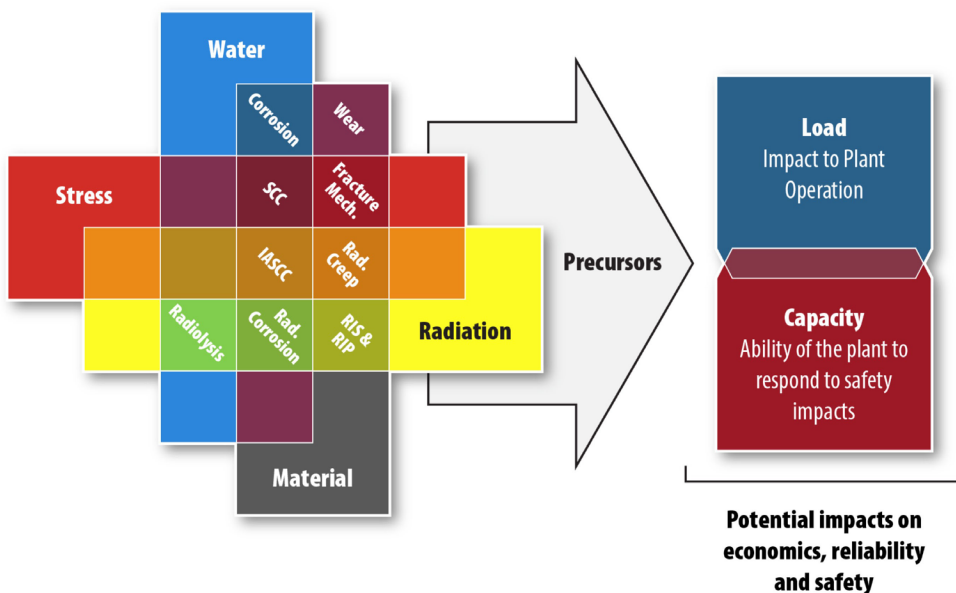
## 2.2 Delivering the Scientific Basis for Continued Safe Operation

### 2.2.1 Understanding and Managing the Aging and Performance of Key Materials for Long Term Operation

Nuclear reactors present a variety of challenging service environments to materials that serve as SSCs. Many components in an operating reactor must tolerate high-temperature water, stress, and vibration, as well as an intense neutron field. Degradation of materials in this environment can affect component performance and, without accurate predictive knowledge of component lifetime or if degradation is left unmitigated, can lead to unexpected and costly repairs or failure of these components while in service. More than 25 different metal alloys can be found within the primary and secondary systems, along with additional materials in concrete, the containment vessel, I&C equipment, cabling, and other support structures. This diversity of material types, challenging environmental conditions, stress states, and other factors make material degradation in a nuclear power plant a complex phenomenon. In simplified form, Figure 17 illustrates that many variables have complex and synergistic interactions that affect materials performance in ways that can impact plant operation or reduce the safety performance of a nuclear power plant. Furthermore, unexpected failures or, conversely, the unnecessary repair of components due to overly conservative estimates of degradation can lead to higher operational costs.

The continued operation of the existing nuclear power fleet beyond 60 years will place continued demands on materials and components in their in-service environments. Understanding the performance of these materials during these longer periods of operation entails characterization of the materials as they age under the demands of in-service conditions and relating that knowledge to the performance characteristics

**Figure 17. Complexity of interactions between materials, environments, and stresses in a nuclear power plant and the impact they have on operations.**



of the different SSCs. The research conducted through the activities described here is intended to provide data, models, methods, and techniques to inform industry on long-term materials performance.

Research activities focus on the following materials and novel mitigation strategies to address aging and degradation: (1) reactor metals, (2) concrete, and (3) cables.

### 2.2.1.1 Reactor Metals

The most key component of an operating nuclear power plant is the reactor pressure vessel (RPV). Although many plant components, including significant structural components, have or may be replaced, the RPV is considered by many as the single non-replaceable component in the plant. Understanding the aging of materials that comprise the RPV is vital to ensuring the long-term performance of a nuclear power plant. The RPV plays an essential safety- role and its integrity must be ensured during a variety of transient loading conditions. These can include off-normal conditions, such as a pressurized thermal shock, as well as transients encountered during normal startup, shutdown, and testing of the reactor.

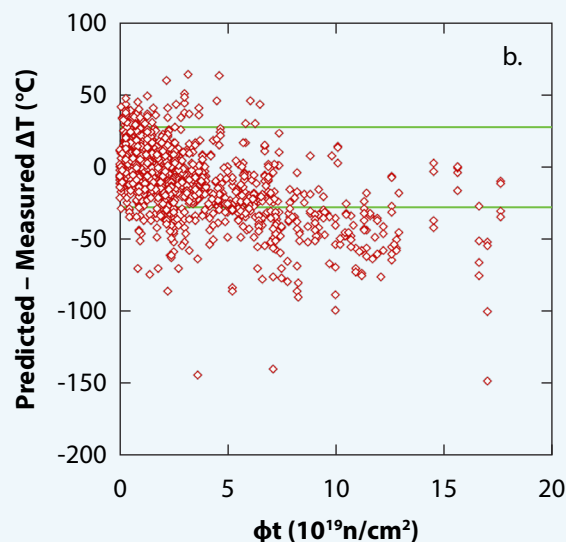
## RESEARCH ACCOMPLISHMENT



### Development of an improved reduced order predictive model of RPV embrittlement

The objective of this research is to examine and understand the influence of irradiation at high fluences on RPV embrittlement. Irradiation of RPV steels may cause embrittlement of the primary containment structure. Acquisition of samples from past programmatic campaigns (such as NRC programs), specimens harvested from decommissioned reactors, surveillance specimens from operating nuclear power plants, and materials irradiated in new test campaigns all have value in the effort to determine high-fluence effects. A key component of this effort has been

**Figure 18. Plot of the difference between the predicted and measured change in Temperature °C vs Fluence.**

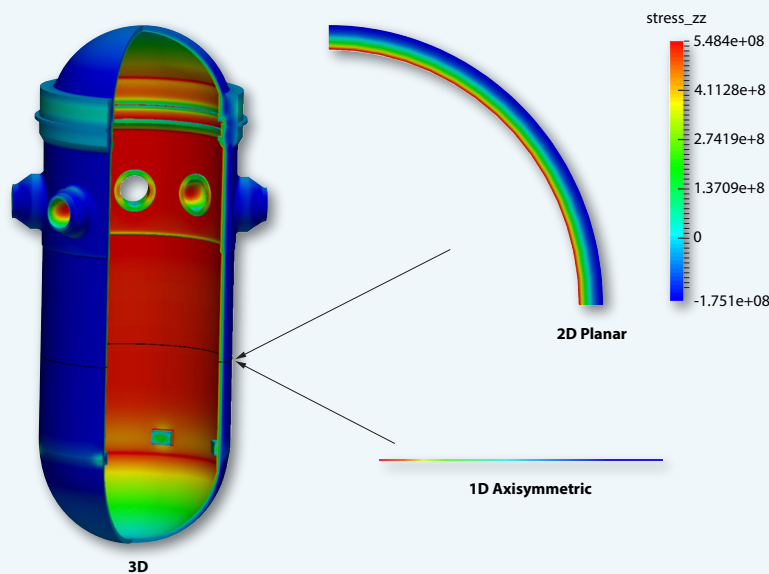


the irradiation of selected alloys at the Idaho National Laboratory's Advanced Test Reactor and testing that included impact and fracture toughness evaluations, hardness, and microstructural analysis (atom probe tomography, small angle neutron scattering, and/or positron-annihilation spectroscopy). The importance of understanding the role of alloy composition, flux, and total fluence is important because current regulatory models— including both the Eason-Odette-Nanstad-Yamamoto (EONY) model and the new American Society for Testing and Materials (ASTM) E900 Standard—can significantly underpredict hardening in steels at high fluence levels as shown in Figure 18.

This research has resulted in the development of a revised model for transition-temperature shifts for RPV steels under a variety of conditions. The results bridge test reactor and surveillance capsule databases for insight into the effects of low flux and high fluence on RPVs. This effort has produced a new reduced order model that includes Nickel-Magnesium-Silicate (Ni-Mn-Si) precipitate formation at high fluence will be used to predict extended RPV life. The Odette, Wells, Almirail, Yamamoto (OWAY) model will be refined and is expected to be used to predict RPV embrittlement over a variety of conditions key to irradiation-induced changes (e.g., time, temperature, composition, flux, and fluence).

Based upon this research, an advanced modeling and simulation code has been developed, referred to as Grizzly. The Grizzly model represents all aspects of RPV performance to provide a comprehensive simulation tool that accounts for aging effects on material properties and the global thermomechanical response of the RPV to loading. This includes fracture analyses of preexisting flaws and their potential for crack propagation in calculating the probability of vessel failure under postulated accident scenarios. The first version of the Grizzly RPV model (Figure 19) was released in 2018.

**Figure 19. Results of one-dimensional axisymmetric, two-dimensional (2D) planar, and 3D Grizzly models of the global response of an RPV at a point in time during a pressurized thermal shock event.**



### 2.2.1.2 Concrete

As concrete ages, changes in its properties will occur as a result of continuing microstructural changes (e.g., slow hydration, crystallization of amorphous constituents, and reactions between cement paste and aggregates) as well as environmental influences. These changes must not be so detrimental that the concrete is unable to meet its functional and performance requirements. Concrete can suffer undesirable changes with time because of improper specifications, a violation of specifications, adverse performance of its cement paste matrix, or adverse environmental influence on aggregate constituents. Changes to the embedded steel reinforcement as well as its interaction with concrete can also be detrimental to concrete's service life. And although activities by several regulatory and international agencies have addressed many aspects of aging nuclear power plant structures, additional structure-related research is needed in several areas to demonstrate that the structures will continue to meet functional and performance requirements (e.g., maintain structural margins).

The long-term performance of concrete in nuclear power plants varies with environmental and operational conditions (temperature, humidity, in-service mechanical loading, and irradiation). A concrete properties database, under development, is a broad encapsulation of materials issues that affect concrete and will be used for aging management and lifetime extension.

#### RESEARCH ACCOMPLISHMENT



#### Development of a Software tool to characterize the response of concrete to environmental factors for long term assessment of material performance

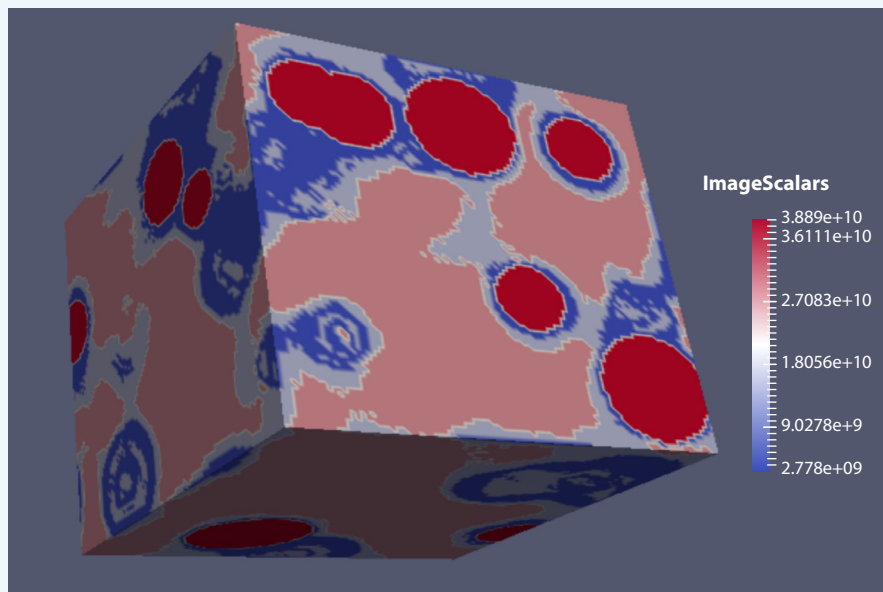
The Microstructure Oriented Scientific Analysis of Irradiated Concrete (MOSAIC) software is being developed to reflect the response of concrete and its components to temperature, moisture, constraint, radiation, creep, and composition variations. It incorporates the large data sets of compositional and phase microscopy, materials properties, and evolving versions of constitutive models to simulate damage to concrete using a fast Fourier Transform Solver. The results of this modeling and simulation effort will provide industry with a tool to assess potential concrete degradation at extended lifetimes and is expected to reduce regulatory safety margins.

The output yields an assessment of the sensitivity of concrete to radiation-induced damage. The materials are heterogeneous paste and aggregates (i.e., rocks) composed of multiple minerals and multiple phases of the same minerals and include dimensional challenges (micron scale and 2D/3D) issues making the combined constitutive model very complex as shown in Figure 20.

Additional experimental studies are planned to validate the model, including characterization and analysis of service-irradiated concrete degradation.

Another mode of degradation being evaluated for its impact on structural-concrete performance is that of alkali-silica reactions that cause swelling of the concrete paste, resulting in cracking and weakening of the shear capacity of the concrete structure. It is the goal of this task to complete the study of the

development of alkali-silica reaction expansion and induced damage of large-scale specimen representative of structural concrete elements found in nuclear power plants. This is being developed through experimentally validated models that explore the structural capacity of alkali-silica reaction -affected structures like the biological shield, the containment building, and the fuel-handling building. Experimental testing has been conducted in accelerated conditions, employing extensive monitoring and nondestructive techniques to evaluate structural stresses generated in large-block test specimens.

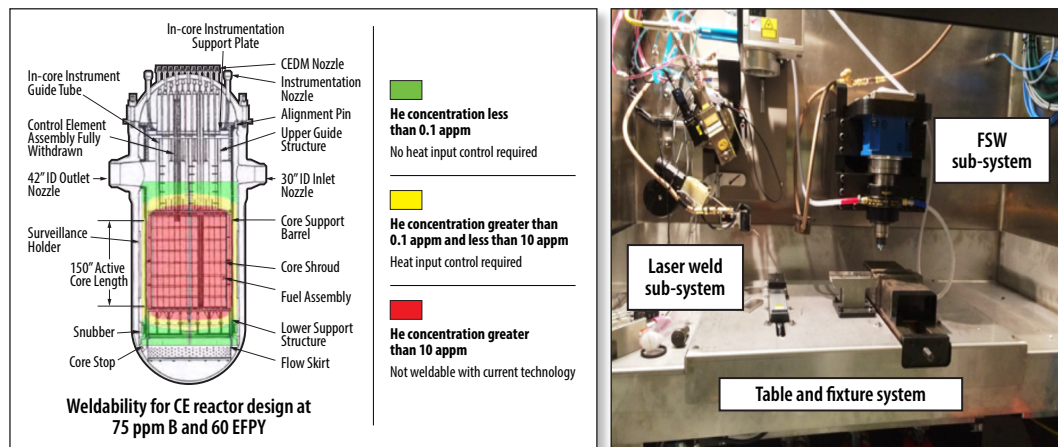


**Figure 20. Microstructure and stiffness map showing damaged areas after thermal expansion of the aggregates.**

### 2.2.1.3 Mitigation and Repair of Materials

Mitigation technologies include weld repair, post-irradiation annealing, water-chemistry modifications, and replacement options for the use of new materials with reduced susceptibility to various modes of degradation. The purpose of this research area is to develop or evaluate mitigation technologies that will reduce susceptibility of materials to degradation and will provide beneficial economic impact through fewer repair or replacement needs.

Research is being conducted to develop advanced welding technologies that can be used to repair highly irradiated reactor internals without helium-induced cracking in the heat-affected zone—a mode of damage controlled by the level of heat input during welding, residual stresses developed, and irradiation level of the material. As shown in Figure 21, radiation-induced transmutation of helium in reactor materials presents significant challenges associated with weld repair that makes current technologies unsuitable. This joint research effort with EPRI began the evaluation of advanced welding techniques (laser and friction stir welding) on the weld repair



**Figure 21. (left) Forecast of helium generation at 75 wppm boron at 60 effective full-power years. Red Zone: >10 appm He (not weldable with current welding processes); Yellow Zone: 0.1 to 10 appm He (weldable with heat-input control during welding repair); Green Zone: <0.1 appm He (no special process control is needed in welding repair).<sup>31</sup> (right) Inside view of the laser and friction-stir weld sub-systems installed in the hot-cell cubicle for testing irradiated materials.**

of alloys with helium contents typical of highly irradiated reactor materials. This work further builds upon the integrated computational welding engineering tool that evaluates residual stresses developed during welding. Applying the integrated computational welding engineering technology to laser welding has the potential to reduce helium-induced cracking in irradiated materials. Identifying the limits of different weld techniques, based on heat input and residual stress in the work piece affecting helium-induced cracking will be valuable to industry stakeholders because these models and weld process-development studies will further improve the practices for repair of irradiated materials.

Research also focuses on weld process development and post-weld characterization. Detailed characterization of the welds is necessary to provide feedback on necessary weld-parameter changes to assure weld quality and to determine the limits of these welding techniques for irradiated materials. Confirmation of weld quality (cracking in the heat-affected zone due to helium-induced embrittlement) and weld properties (mechanical strength, microstructural stability) will be necessary to gain industry assurances in the process. Research steps are part of the larger effort to provide the industry with techniques to overcome welding difficulties associated with highly irradiated components.

### 2.2.2 Addressing Aging and Obsolescence of Plant Technologies

The instrumentation and control technologies (I&C) across today's nuclear fleet are largely based on analog technology shown in Figure 22. In other power-generation sectors, analog technologies have largely been replaced with digital technologies. Analog I&C continues to function reliably in the nuclear industry, though spare and replacement parts are becoming increasingly scarce as is the workforce that is familiar with and able to maintain analog I&C. Even though there is a significant obsolescence management challenge to maintain the current systems, the nuclear



**Figure 22. Much of the current instrumentation and controls in a nuclear power plant control room is analog technology.**

industry has been slow to modernize. This is largely due to the perception that replacing existing analog with digital technologies involves significant technical and regulatory uncertainty. This perception was largely formed when early attempts to modernize these systems encountered delays and substantially higher costs than initially predicted. Such experiences have slowed the pace of analog I&C replacement and further contribute to a lack of experience with such initiatives. In the longer term, these I&C refurbishment delays put the nuclear industry at a distinct disadvantage to remain competitive in future energy markets due to the rising costs to maintain and operate these systems.

Such delays could lead to an additional dilemma: delays in reinvestment needed to replace existing I&C systems could create a “bow wave” for needed future reinvestments. Because the return period on reinvestments becomes shorter, the longer they are delayed, the less financially viable they become. This adds to the risk that I&C may become a limiting or contributing factor that weighs against the decision to operate nuclear power assets for longer periods.

It could ultimately result in a collection of systems in use at operating plants that are based upon analog I&C which are more costly to maintain than modern digital systems, require a specialized workforce, and are not supported by modern I&C supply chains. It will also reflect and maintain a business model for plant operation that is highly labor-centric and is tied to rising costs of labor rather than the declining costs of modern technology.

Research into I&C technologies and systems for plant operation are being carried out to develop the needed technologies to achieve performance improvement through control-room enhancements with digital upgrades to achieve modernization towards long-term plant end-state I&C architectures. These projects target realistic opportunities to improve control-room performance with distributed control systems



**Figure 23. Human Systems Simulation Laboratory: a reconfigurable hybrid control room simulator.**

and plant-computer upgrades. This research employs unique DOE facilities and test beds shown in Figure 23, that provide a realistic setting for development and validation new digital technologies to be retrofit into existing nuclear power plants. In addition, the LWRS Program participates in the Halden Project and is able to leverage control-room upgrade research and technologies for use within the U.S. fleet.

## RESEARCH ACCOMPLISHMENT



### **LWRS Program and Industry Team complete cost analysis and conduct design studies for first major safety-related digital upgrade in the U.S. in almost a decade**

In 2020, Exelon Generation, ScottMadden, Inc., MPR Associates, and LWRS Program researchers created and leveraged a process and related business case tools to perform a business case analysis for a major digital safety system upgrade at an operating commercial nuclear power plant. The ultimate purpose of this research is to communicate the process and related business case tool to enable similar business case analyses for digital upgrades throughout the industry along with providing supporting design concept information. These methodologies can be abstracted and used by industry as tools to help justify nearly any I&C system upgrade.

The business case analysis established forecasted lifecycle costs for current I&C systems identified for upgrade at Exelon's Limerick Generation Station (LGS). A key finding was that costs to maintain certain existing I&C systems are growing at an accelerated rate as shown in Figure 24 below, not at a linear rate as industry had previously supposed. This is reflected in the steeply increasing slope of the 'Material Trendline' in the figure, which shows a near exponential rise in the costs of replacement parts for aging analog technologies since 2010.

Through a parallel design effort, engineers familiar with the envisioned digital upgrade equipment attributes identified cost savings categories and expected savings in those categories resulting from the transition from analog to digital technologies. These savings were then analyzed. The result identified a positive estimated Net Present Value (NPV) of upgrade enabled savings for the major safety related systems in the plant (Reactor Protection System, Engineered Safety Features





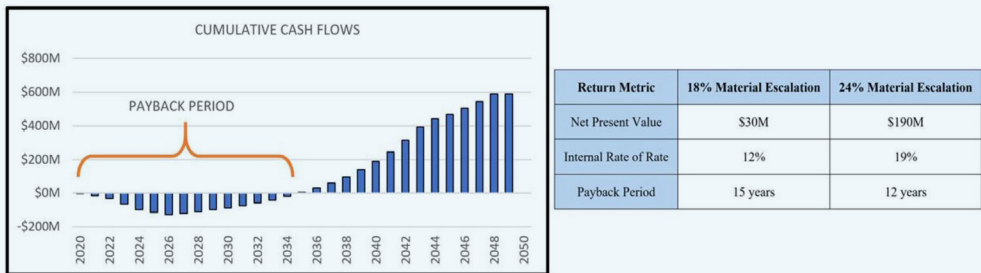
**Figure 24. Sample system labor and material cost analysis.**

Actuation System, Emergency Core Cooling System, and Anticipated Transient Without Scram function). This includes both direct cost savings (e.g., surveillance labor costs) and cost avoidance items (e.g., inventory carrying costs). When utility-provided upgrade cost estimates were then included, the resultant BCA provided a complete NPV for the upgrade project. Illustrative research results representative of the scale of potential benefits identified are shown in Figure 25. Depending upon varying material cost escalation rates observed from Figure 24, the illustrative payback period and NPV vary as shown in Figure 25.

This effort specifically supported Exelon’s decision to move forward with a safety-related digital upgrade project at LGS. Conceptual Design Phase activities for the LGS project will occur in 2021. The current project timeline installs the upgrades in LGS Unit 1 in 2024 and Unit 2 in 2025.

This research was performed to assist in breaking the impasse the industry has experienced with regard to performing safety system digital upgrades. This research not only supports the LGS specific upgrade, but provides design requirements baselines, design concepts in a licensing product format, and business case analysis tools that can be leveraged by the nuclear industry to develop and economically justify similar upgrades.

For more information, this, and other safety-related I&C upgrade related research is provided at: [https://lwrs.inl.gov/SitePages/IC\\_Plant\\_Modernization\\_Pilot\\_Project.aspx](https://lwrs.inl.gov/SitePages/IC_Plant_Modernization_Pilot_Project.aspx).



**Figure 25. Illustration of representative cumulative cash flows and aggregate business case metrics**

## References

- <sup>1</sup> U.S. Nuclear Generating Statistics. Published online by the Nuclear Energy Institute at [www.nei.org](http://www.nei.org)
- <sup>2</sup> U.S. Energy Information Administration. Short Term Energy Outlook, January 2019 [www.eia.gov](http://www.eia.gov)
- <sup>3</sup> Potomac Economics. 2015. 2014 State of the Market Report for the MISO Electricity Markets. Fairfax VA.
- <sup>4</sup> Abel D. 2016. Carbon emissions rising at New England power plants. Boston Globe, May 15.
- <sup>5</sup> Content T. 2014. Kewaunee closing makes Wisconsin's task to meet EPA rules tougher. Milwaukee Journal Sentinel, Jun 14.
- <sup>6</sup> NEI. 2017. Testimony for the record, Senate Public Utilities Committee, State of Ohio, Jun 8. Online at <https://www.nei.org/CorporateSite/media/filefolder/resources/testimony/testimony-nei-korsnick-ohio-senate-public-utilities-committee-20170608.pdf>.
- <sup>7</sup> Berkman MP, Murphy DM. 2015. The Nuclear Industry's Contribution to the US Economy. Boston: Brattle Group.
- <sup>8</sup> <https://www.exeloncorp.com/newsroom/exelon-generation-to-retire-illinois%E2%80%99-byron-and-dresden-nuclear-plants-in-2021>.
- <sup>9</sup> Delivering the Nuclear Promise: Advancing Safety, Reliability and Economic Performance, March 2018, NEI.
- <sup>10</sup> 10 CFR 54, "Requirements for Renewal of Operating Licenses for Nuclear Power Plants," Code of Federal Regulations.
- <sup>11</sup> "Memorandum of Understanding between United States Department of Energy (DOE) and The Electric Power Research Institute (EPRI) on Light Water Reactor Research Programs," dated December 15, 2015, and signed by John E. Kelly, Deputy Assistant Secretary for Nuclear Reactor Technologies, Office of Nuclear Energy, DOE, and Neil Wilmshurst, Vice President Nuclear, EPRI.
- <sup>12</sup> "Memorandum of Understanding between U.S. Nuclear Regulatory Commission and U.S. Department of Energy on Cooperative Nuclear Safety Research," dated May 01, 2014, and signed by Brian W. Sheron, Director, Office of Nuclear Regulatory Research, NRC, and John E. Kelly, Deputy Assistant Secretary for Nuclear Reactor Technologies, DOE-NE.
- <sup>13</sup> <https://www.ans.org/news/article-183/us-nuclear-capacity-factors-resiliency-and-new-realities/>
- <sup>14</sup> Thomas, K.T. et al, Analysis and Planning Framework for Nuclear Plant Transformation, August 2020, INL/EXT-20-59537
- <sup>15</sup> N. Goss et al., "Integrated Risk-informed Condition-Based Maintenance Capability and Automated Platforms: Technical Report 1," PKM-DOC-20-0013, Rev. 0, June 15, 2020.

- <sup>16</sup> National Institute of Standards and Technology, "US Government Cloud Computing Technology Roadmap Volume I: High Priority Requirements to Further USG Agency Cloud Computing Adoption," Special Publication 500-293, October 2014.
- <sup>17</sup> National Institute of Standards and Technology, "US Government Cloud Computing Technology Roadmap Volume II: Useful Information for Cloud Adopters," Special Publication 500-293, October 2014.
- <sup>18</sup> Elgowainy, A., et al, Assessment of Potential Future Demands for Hydrogen in the United States, October 2020, ANL-20/35
- <sup>19</sup> Ruth, M.F. et al., The Technical and Economic Potential of the H2@Scale Concept within the United States. Golden, CO: National Renewable Energy Laboratory. 2020, <https://www.nrel.gov/docs/fy21osti/77610.pdf>.
- <sup>20</sup> Boardman, et al. Evaluation of Non-electric Market Options for a Light Water Reactor in the Midwest, August 2019, INL/EXT-19-55090
- <sup>21</sup> Glover, et. al., Final Report on Hydrogen Plant Hazards and Risk Analysis Supporting Hydrogen Plant Sitting near Nuclear Power Plants, July 2020, SAND2020-7946
- <sup>22</sup> Vedros, K. et al., Probabilistic Risk Assessment of a Light Water Reactor Coupled with a High-Temperature Electrolysis Hydrogen Production Plant, October 2020, INL/EXT-20-60104
- <sup>23</sup> Hong, H, et al., Technoeconomic Analysis on an Electrochemical Nonoxidative Deprotonation Process for Ethylene Production from Ethane, December 2019, INL/EXT-19-56936
- <sup>24</sup> Knighton, L.T. et al., Techno-Economic Analysis of Synthetic Fuels Pathway Integrated with Light Water Reactors, September 2020, INL/EXT-20-59775
- <sup>25</sup> Knighton, L.T. et al., Markets and Economics for Thermal Power Extraction from Nuclear Power Plants for Industrial Processes, March 2020, INL/EXT-20-58884
- <sup>26</sup> Knighton, L.T., et al, Scale and Regionality of Nonelectric Markets for U.S. Nuclear Light Water Reactors, March 2020, INL/EXT-20-57885
- <sup>27</sup> Knighton, L.T. et al., Accelerating Decarbonization- Clean Energy Credits to Produce Low Carbon Hydrogen, Steel, and Ammonia Using Nuclear, May 2020, INL/EXT-20-58508
- <sup>28</sup> Hancock, S., et al., Incorporation of Thermal Hydraulic Models for Thermal Power Dispatch into a PWR Power Plant Simulator, June 2020, INL/EXT-20-58766
- <sup>29</sup> Ulrich, T.A. et al, Remote Operator Thermal Power Dispatch Concept of Operations Evaluation, September 2020, INL/EXT-20-00626
- <sup>30</sup> Vedros, K. et al., Probabilistic Risk Assessment of a Light Water Reactor Coupled with a High-Temperature Electrolysis Hydrogen Production Plant, October 2020, INL/EXT-20-60104
- <sup>31</sup> Source: EPRI report, EPRI BWRVIP-97A.

