

Inter-laboratory Test Planning Document for New ASTM C28.07
Standard for Axial Tensile Properties of Ceramic Composite Tubes

Yutai Katoh and Stephen T. Gonczy*

Oak Ridge National Laboratory
*Gateway Materials Technology, Inc.

March 2014

1. Introduction

The ASTM Committee C28 on Advanced Ceramics has published a standard test method for the “Monotonic Axial Tensile Behavior of Continuous Fiber-Reinforced Advanced Ceramic Tubular Test Specimens at Ambient Temperature (C1773).” ASTM specifies that the precision, repeatability, and reproducibility of the test method be addressed in published test standards. The preferred method of determining those variables is by an inter-laboratory study (ILS) of the test method. ASTM has written and published a comprehensive practice for planning, conducting, analyzing, and reporting on an ILS (ASTM E691).

This planning document is a detailed plan for a proposed ILS study on the “Monotonic Axial Tensile Behavior of Continuous Advanced Ceramic Composite Tubular Test Specimens at Ambient Temperature” based on the guidelines of E691 and the standard C1773 Axial Tensile Strength of Ceramic Composite Tubes standard. This document provides objectives, outlines planning issues, and lists proposed tasks for laboratories and the organizer.

2. Baseline facts and assumptions

The fundamental objective in an inter-laboratory study is to determine the inherent variability and precision in a given test method, given nominally identical test specimens. This variability in experimental results is expressed in terms of repeatability (*variation in test results obtained with the same method on identical test items in the same laboratory by the same operator using the same equipment within short intervals of time*) and reproducibility (*variation in test results obtained with the same method on identical test items in different laboratories with different operators using different equipment*). [From ASTM E691 -- Standard Practice for Conducting an Interlaboratory Study to Determine the Precision of a Test Method]

The axial tensile strength test of ceramic matrix composite (CMC) tubes is a complex test with a wide range of experimental variables (composite properties, specimen configuration, test parameters, etc. See Appendix A) which have to be defined, controlled, and measured. In the ideal world, all of the different variables could be assessed against the axial tensile strength to determine how much variation develops from each variable. However, this is not practical in terms of testing time, costs, material, and effort. However, test engineers know there are critical variables which have very significant effect on test results and should be evaluated on a high priority.

The ILS project should be structured into phases to address the key test variables in a structured priority. This focus on the prioritized factors is necessary to effectively manage costs, materials, and effort, and will provide a progression of “lessons learned.” In my opinion the priority variables in the ILS study should be –

- CMC test specimen geometry –
 - Straight sided specimen versus reduced gage section specimen. CMC gripping method will depend on specimen type.
 - Wall thickness effects
 - Gage length effects
- CMC composition, morphology, and structure
 - Fiber architecture
 - Porosity levels
 - Fiber type, matrix composition, component fractions

3. Phase 1 Inter-laboratory study objective

Objective – Determine the repeatability and reproducibility of the axial tensile test method at ambient temperatures with one **primary** specimen geometry for one specific composite composition.

With success in Phase 1, future ILS studies can address the follow-on priority test issues, such as alternative composite compositions and fiber architectures, porosity effects, variations in wall thickness and gage length, alternative gripping methods, effects of specimen preparation, and testing parameter variations (strain rate, misalignment etc.).

4. Planning considerations

Material and test parameters

ORNL has two sets of SiC-SiC tubes on hand that are suitable and available for tube tensile testing. These tubes are made by Hypertherm High Temperature Composites with braided Hi-Nicalon Type S or Hi-Nicalon and densified with chemically vapor-infiltrated (CVI) silicon carbide. The primary geometry is a 5” long tube with a 0.56” gage outer diameter (OD), a 0.08” gage wall thickness, and 8° tapered shoulders. The second geometry is 5” long tube with a 0.565” gage OD, a 0.08” gage wall thickness, and 1° tapered shoulders. Tubes with the second geometry is currently assumed to be used for ILS testing.

With a planned set of 50 tube specimens for testing at 10 laboratories, each laboratory specimen set will have 5 test specimens for testing at ambient temperatures.

The experimental plan, detailing materials, specimen geometry, test equipment and fixturing, and experimental methods for the axial tube tensile strength ILS, is summarized in Table 1.

Table 1 – Summary of ILS plan.

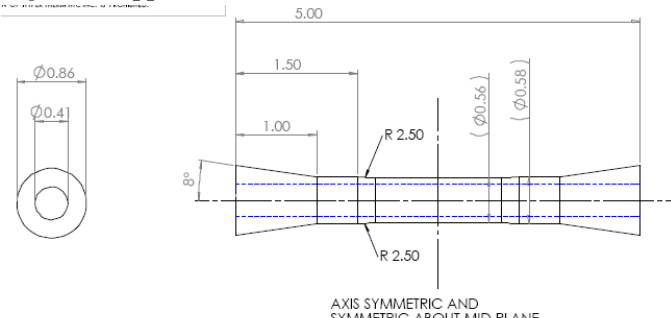
Test Specimens	
Composite	SiC-SiC Composite tubes - Two-dimensional ($\pm 55^\circ$) biaxial braiding with nine (9) braid layers of Hi-Nicalon Type S SiC fibers (multilayer PyC interface) with CVI SiC matrix (<15% porous). Produced by Hyper-Therm HTC Inc.
Specimen Geometry and Size	<p>5” (125 mm) long tube with 8° tapered shoulders. Gage OD = 0.56” (14 mm), Gage ID = 0.40” (10 mm), Wall Thickness = 0.08” (2 mm), Gage length =2.5”(62 mm) Figure in Appendix B</p> 

Nominal Composite Mechanical Properties	Tensile Strength = ~100 MPa, Strain at Failure = 0.8%, Prop. Limit (PL) Stress (0.05% offset) = ~80 MPa PL Strain = ~0.03 % Elastic Modulus = ~250 GPa Failure Mode = semi-brittle, pseudo-ductile
Dimens. Tolerances	Per spec at Hyper-Therm HTC
Specimen Preparation	Preparation and OD grind of all specimens at Hyper-Therm HTC
Visual Inspection	At ORNL and at each Test Laboratory
Measurement	OD and ID Dimensions (at ORNL and each Laboratory) Ultrasound for wall thickness at ORNL and calipers pre- and post-test
Specimen Conditioning	None
Test Equipment and Experimental Parameters	
Test Temperature/ Environment	Ambient temperature, no environmental chamber nor furnace required. Humidity Measurement
Test Machine	Tensile Loading with Tensile Load Cell (20 kN Capacity with 1% Accuracy)
Fixtures	Split Tapered Collets and Support Collar and copper plugs (supplied by ORNL) suitable for fixed and non-fixed load train couplers. <i>See Appendix C</i>
X-Head Rate (mm/min)	1 mm per minute (typically 20-30 seconds failure time)
Extension and Strain Measurement	Strain measurement is required, either by Clip on extensometer/s (1" gage recommended) or by two or more strain gages.
Alignment and Bending Stress Check	Strain gaged alignment specimen provided by ORNL. Testing laboratories will check alignment.
Specimen Dimensions Measurement	Precision Calipers/Micrometers pre and post test. Ultrasound for wall thickness at ORNL
Measured and recorded test data	Applied force and extension/strain as a function of time/X-head movement.
Data Collection	Digital (Force and Extension vs. Time, and Max Force) Suggested collection rate – 40 points per second
Calculated data	Ultimate tensile strength, ultimate tensile strain, Proportional limit stress (0.05% offset), PL strain Elastic modulus
Fracture Analysis	Done at ORNL

ILS participants and responsibility

It is preferred that the participating institutions include industrial, government, and academic laboratories. A minimum of six (6) laboratories are needed and having eight (8) laboratories participating is preferred. The thirty (30) test specimens will be divided between the final laboratories. It is desirable to have at least 25 valid tests for the ILS.

Each laboratory will be provided one set of 4-5 test specimens ready for ambient temperature testing along with a set of two collet-grip fixtures and one strain-gaged alignment specimen. The critical project steps that each laboratory will have to do are:

- 1) Provide the necessary tensile test machine and verify the accuracy/calibration/ alignment/ tolerances of the testing machine and supporting equipment (measurement devices, data collection systems, etc.)
- 2) Use the split tapered collets and support collars for specimen gripping, which will be provided by ORNL. Participating laboratories will provide suitable load train couplers for mounting the split collet fixtures into their tensile test system.
- 3) Strain measurement is required, either by extensometer measurements across a 1” gage of the tube specimens or by strain gages (two or more) on the specimen . Extensometer measurements are encouraged, but laboratories may use strain gages if they prefer. Strain gages, if used, will be supplied and mounted by the laboratories.
- 4) Provide strain gage equipment to support specimen alignment checks with the provided strain-gaged alignment specimen.
- 5) Accept and properly store the specimens prior to testing.
- 6) Maintain identification and traceability of all specimens.
- 7) Provide a trained and experienced test operator.
- 8) Check the alignment in the load train and adjust to minimize extraneous bending stresses, per the test protocol.
- 9) Prior to testing, visually examine and then measure and record the OD dimensions of the test specimens in accordance with the test standard. Diameter measurements will require precision calipers and micrometers.
- 10) Conduct the axial tensile test in accordance with the provided test standard and protocol, considering specimen insertion, extension/strain measurement, preload, loading rates, failure modes, data collection, fracture specimen collection, post-test dimensions, etc.
- 11) Measure the wall thickness of the fractured test specimens.
- 12) Screen test results for invalid tests and do replacement tests as necessary.
- 13) Prepare and submit test data reports (on the provided XLS spread sheet format) to the ILS coordinator in accordance with the ILS axial tensile test protocol.
- 14) Return tested specimens to the ILS coordinator.

Responsibility of organizer

As the organizer, ORNL has to provide the following –

- Thirty (30) SiC-SiC composite tube test specimens, machined to specifications and measured for dimensions. Specimens should be marked and identified for traceability.
- At least three sets of split-collet-collar gripping fixtures (2 fixtures per set) that fit the defined specimen geometry. (Gripping fixtures will travel sequentially to each laboratory with the test sets.)
- At least two strain-gaged SiC-SiC composite tube test specimens for system alignment and bending stress checks.

5. Conclusions

Detailed plan for a ILS study on the “Monotonic Axial Tensile Behavior of Continuous Advanced Ceramic Composite Tubular Test Specimens at Ambient Temperature” based on the guidelines of E691 and C1773 Standard Test Method for Axial Tensile Strength of Ceramic Composite Tubes standard was developed summarizing objectives, planning considerations, and tasks for laboratories and organizer.

Appendix A – Variables in Axial Tube Tensile Testing

Material Variables	Specimen Variables	Test Equipment Variables
Composite Components (Fiber, Matrix, Fiber Interface Coating) Relative fractions	Specimen Geometry- diameters (OD and ID), wall thickness, gage length, grip section geometry dimensions	Load Train Alignment and Extraneous Bending Stresses
Mechanical Properties of Components and their Interaction	Variation in Critical Dimensions and Geometry Features	
Density, Porosity Fraction	Test Specimen Volume Effects	Test Method Variables
Fiber/Fabric Architecture – Geometry, Alignment, Volume Fraction	Pre-test Conditioning and Exposure Treatments	X-Head (Displacement) Rate
Flaw Characteristics and Populations – Surface and Volume Flaws	Specimen Preparation Method (Cutting and Machining) and surface effects	Test Environment Effects (Air, Humidity and Temperature)
Spatial Variations in all of the above	Storage Effects	Slack Removal and Preload
Tube-to-Tube and Lot-to-Lot Variations in all of the above		Invalid and Censored Tests (Out-of-Gage Failures)
Composite Fabrication Parameters and Pedigree		Fracture Analysis

Appendix B – Axial Tensile Tube Test Specimen Geometries

Geometry #1 – SiC-SiC Composite Tube

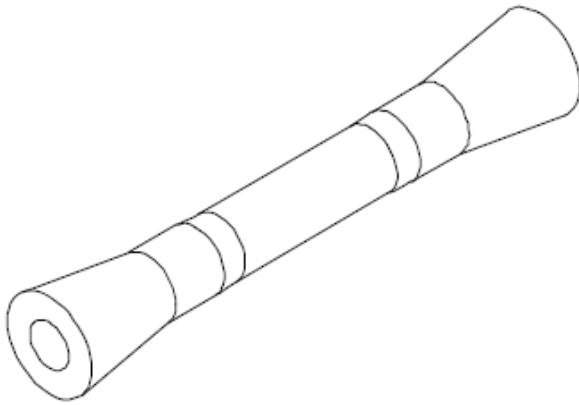
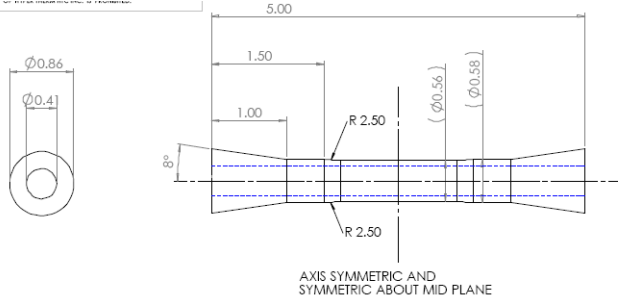

Geometry #2 -- SiC-SiC Composite Tube

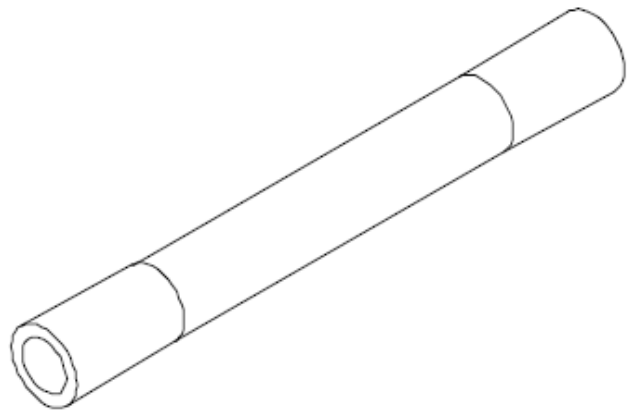
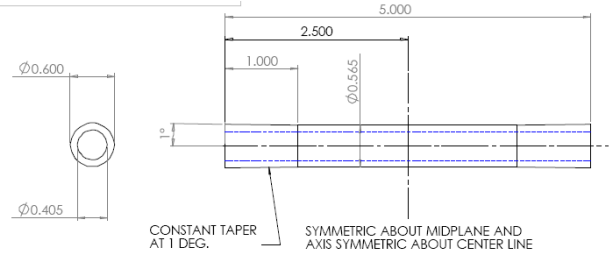

Appendix C – Split Collet and Support Collar for Tapered Shoulder Specimens



Appendix D – Laboratories to be invited to participate

<u>Government -- Priority 1</u> Katoh -- ORNL, Shannon Black -- INL, Jon Salem-NASA Glenn, -- <u>Priority 2</u> Sung Choi – Navair, Zawada –AFML	<u>Industry -- Priority 1</u> General Atomics, Westinghouse, -- <u>Priority 2</u> Ojard- UTRI, GE-Evendale, Luthra -GE- CRD, Armstrong--Rolls Royce,	<u>Producers -- Priority 1</u> Rolls-Royce HTC
<u>University -- Priority 2</u> Vasudevanmurth -Virginia Commonwealth, Michael Jenkins – CSU- Fresno Leon Chuck, UDRI	<u>Independent Testing Labs -- Priority 2</u> Cincinnati Testing Labs Southern Research Exova	

Appendix E – Test Protocol Document

ASTM C-28 ADVANCED CERAMICS COMMITTEE

Month DD, YYYY

Mr. XXXX
Organization AAAA
Street Address
City, State Zip

Dear XXXX,

We are ready to begin our interlaboratory study (ILS) on the uniaxial tensile strength of ceramic matrix composite tubes, using the new ASTM C1773 Standard Test Method (Monotonic Axial Tensile Behavior of Continuous Fiber-Reinforced Advanced Ceramic Tubular Test Specimens at Ambient Temperature). The objective of this first ILS is to:

1. Determine the repeatability and reproducibility of the axial tensile tube (ATT) test method (ASTM C 1773) at ambient temperatures for an SiC-SiC ceramic composite with one primary tube geometry. The properties of interest are ultimate tensile strength and strain, proportional limit (0.05% offset) stress and strain, and elastic modulus in tension.

We have laid out a detailed experimental plan for the ILS, using a SiC-SiC composite tube with a defined geometry (**5" long tube with 1° tapered shoulders. Gage OD = 0.56", Gage ID = 0.40", Nominal Gage Length = 2.5"**). The CMC tube test specimens will be tested at ambient temperature. Each test set will have 5 test specimens for each participating laboratory. (The full test plan and instructions are laid out in Appendix E2)

Test specimen sets are being sent to you and 6 other laboratories for testing. This test package contains the following items –

1. Introduction letter
2. Participation agreement (Appendix E1) to use the specimens only for the axial tensile strength testing and return all test specimens after test.
3. Test protocol and instructions (Appendix E2) and a procedure checklist. (Appendix E3)
4. A copy of the ASTM C1773 ATT test method, print (Appendix E4) and PDF file on the CD.
5. One test specimen set with 5 ATT test specimens in each set, ready for testing.
6. An alignment specimen with applied resistance strain gages.
7. The two collet grip fixtures (top and bottom) for the ATT tests.
8. Copper collets and graphite end plugs for the test specimens. (*Reusable copper collets or one set of two for each specimen*)
9. A CD-ROM with the data report in an MS- EXCEL™ spreadsheet format (ATTDataSheet.XLS).
10. A printed copy of the MS- EXCEL™ data spread sheet format for your review. (Appendix E5)

With these test specimens, grip fixture and collets, alignment specimen, and instructions, you have the materials and information needed to complete your portion of the ILS. The detailed ILS testing tasks are listed in Appendix E1 and in the ILS check list (Appendix E3)

The success and value of the ILS effort depends on three factors –

1. All of the CMC tube test specimens in each test set are uniform in physical and mechanical properties.
2. All of the participating laboratories prepare their equipment, measure the specimens, and perform the ATT tests according to the ASTM C1773 test standard (Appendix E4) and the test procedure checklist (Appendix E3).

3. The participating laboratories complete the testing in a timely manner and promptly return all the formatted test data and fractured and unfractured test pieces to the test coordinator.

For scheduling purposes, we are aiming for test completion and data reporting by all laboratories by **Month DD, YYYY**.

If you have technical (samples or testing procedures) or administrative (data and reporting requirements, shipping/packaging) questions about this package and the test pieces, please call –

<u>Admin Contact = Stephen T. Gonczy,</u> <u>Gateway Materials Technology, Inc.</u> Tel: 847-870-1621, E-Mail = gatewaymt@aol.com	<u>Technical Contact = Yutai Katoh,</u> <u>Oak Ridge National Laboratorys</u> Tel : 865-576-5996 E-mail: katohy@ornl.gov
---	--

Your participation in the ILS is much appreciated. We look forward to your contribution of time and effort to this technical project which supports aerospace and nuclear ceramic composites technology and the development of ASTM advanced ceramics standards.

Steve Gonczy
Gateway Materials Technology
22 S. Emerson,
Mount Prospect, IL 60056

Yutai Katoh
Oak Ridge National Laboratory
Materials Science and Technology Division
Oak Ridge, TN 37831

Appendix E1 – ILS Participation Agreement

PARTICIPATION AGREEMENT

ORNL and ASTM C28 INTERLABORATORY STUDY (ILS) ROUND ROBIN ON
CMC TUBE AXIAL TENSILE TESTING
Month YYYY – Month YYYY

Our organization _____ located in
_____ agrees to participate in the 2014
ASTM C28 ILS round robin on Axial Tube Tensile Testing of Ceramic Matrix Composites under
the following terms and conditions-

1. We accept the set of SiC-SiC CMC tube test specimens and we will test them per the included project documents – ILS round robin ATT test plan and ASTM 1773. (*See the task list on the following page.*)
2. This testing will be done as a no-cost, in-kind participation in the ILS round robin project.
3. The CMC tube specimens will be used exclusively for the ILS round robin test. We will not do any other property testing or chemical/structural analysis on the CMC test specimens.
4. The CMC tube specimens and the produced data may be subject to U.S. federal export control requirements (EAR and/or ITAR) and should be protected and handled in accordance with applicable laws and regulations.
Arms Export Control Act (TITLE 22, U.S.C., Sec 2751 et seq.) or the Export Administration Act of 1979, as amended, Title 50, U.S.C., App. 2401 et. seq. Violations of these export laws are subject to severe criminal penalties
6. We will return all the test specimens (broken and unbroken) after completion of testing to the project coordinator Stephen Gonczy (Tel: 847-870-1621, E-Mail: gatewaymt@aol.com)

Stephen T. Gonczy Gateway Materials Technology, Inc. 221 S. Emerson Mount Prospect, IL 60056

Signature

Date

Printed Name and Title

Please complete, sign, and return this agreement by e-mail or FAX before the start of testing to Stephen Gonczy, Gateway Materials, gatewaymt@aol.com FAX: 847-870-1624
Yutai Katoh, ORNL, katohy@ornl.gov FAX: 865-241-3650

TASK LIST FOR THE AXIAL TUBE TENSILE TEST ILS STUDY	
PACKAGE RECEIPT AND SPECIMEN CHECK	
1.	Check the test package for completeness -- the ILS instructions, the procedure checklist (App. 3), the ASTM C1773 standard (App. 4), and the included test specimens, grip fixtures, and collets, graphite plugs, and alignment specimen
2.	Review the test plan and procedures described in this letter and appendix. Review, sign, and return (e-mail or FAX) the participation agreement (Appendix 2) to Steve Gonczy (gatewaymt@aol.com , FAX 847-870-1624).
3.	Check the count and condition of the SiC-SiC specimens in the test set and store them in their original packaging in a dessicator until testing.
4.	Check the alignment specimen, the two split collar grip fixtures, the copper collets and the graphite plugs for count and condition. Check how the grip fixtures will be fitted into your test system, accounting for proper alignment.
5.	Check that the Excel spread sheet (ATTDataSheet.XLS) on the CD can be opened.
Specimen Tensile Testing	
6.	Review the ILS instructions, the procedures checklist (App. 3), and the ASTM C1773 test standard (App. 4).
7.	Set up and check the testing equipment for specimen insertion and alignment, force measurement, displacement control, and strain measurement, per the attached checklist (App. 3) and the ASTM C1773 test standard (App. 4)
8.	Measure and record outer diameter dimensions (3 measurements at 3 locations in the gage section) of each specimen.
9.	Complete 5 valid ATT tests per the attached checklist (App. 3) and the ASTM C1773 standard (App. 4).
10.	Measure and record the OD and wall thickness of each specimen at three points close to the fracture site
11.	Record (in the MS- EXCEL file) and review the specimen data, experimental data, test data, and force-extension/strain data for completeness and accuracy. Send the completed data EXCEL spread sheet file by e-mail to Steve Gonczy (gatewaymt@aol.com)
12.	Collect, package, and send the fractured test specimens, any unused specimens and completed checklists to Steve Gonczy

Steve Gonczy, Gateway Materials Technology
221 S. Emerson, Mt. Prospect, IL 60056
847-870-1621

Appendix E2

General Instructions for CMC Axial Tensile Tube Strength ILS Study

Objectives

The objective of this multi-laboratory ILS is to determine the repeatability and reproducibility of the axial tensile tube (ATT) test method (ASTM C 1773) at ambient temperatures with one primary tube geometry for an SiC-SiC ceramic composite. The properties of interest are ultimate tensile strength, proportional limit stress, and elastic modulus in tension.

Materials

There is one (1) set of CMC ATT test specimens provided for the ILS study. Each set contains 5 test specimens.

The CMC ATT test specimens have been cut, finished, and measured at Hyper-Therm and ORNL per the C1773 test standard. The specimens have been marked and logged with specimen identification numbers.

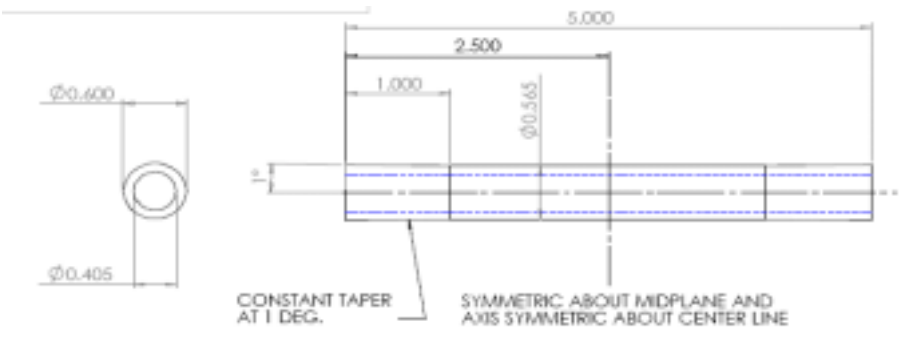
Test Specimens	
Composite	SiC-SiC Composite tubes - Two-dimensional ($\pm 45^\circ$) biaxial braiding with nine (9) braid layers of Hi-Nicalon SiC fibers (multilayer PyC interface) with CVI SiC matrix (<15% porous). Produced by Hyper-Therm HTC Inc.
Specimen Geometry and Size	<p>5" (125 mm) long tube with 1° tapered shoulders. Gage OD = 0.56" (14 mm), Gage ID = 0.40" (10 mm), Wall Thickness = 0.08" (2 mm), Gage length = 2.5" (62 mm) <i>Figure in Appendix 2</i></p>  <p style="text-align: center;">CONSTANT TAPER AT 1 DEG. SYMMETRIC ABOUT MIDPLANE AND AXIS SYMMETRIC ABOUT CENTER LINE</p>
Nominal Composite Mechanical Properties	<p>Tensile Strength = ~100 MPa, Strain at Failure = ~0.8%, Prop. Limit (PL) Stress (0.05% offset) = ~80 MPa, PL Strain = 0.03 % Elastic Modulus = ~250 GPa Failure Mode = semi-brittle, pseudo-ductile</p>
Dimens. Tolerances	Per spec at Hyper-Therm HTC
Specimen Preparation	Fabrication and OD finish of all specimens at Hyper-Therm HTC
Visual Inspection	At ORNL and at each Test Laboratory
Measurement	<p>OD and ID Dimensions (at ORNL and each Laboratory) Ultrasound for wall thickness at ORNL and calipers pre- and post-test</p>
Conditioning	None

Test Equipment and Experimental Parameters	
Test Temperature/ Environment	Ambient temperature, no environmental chamber nor furnace required. Humidity Measurement
Test Machine	Tensile Loading with Tensile Load Cell (20 kN Capacity with 1% Accuracy)
Fixtures	Split Tapered Collets and Support Collar and copper plugs (supplied by ORNL) suitable for fixed and non-fixed load train couplers. <i>See Appendix 3</i>
X-Head Rate (mm/min)	1 mm per minute (typically 20-30 seconds failure time)
Extension and Strain Measurement	Strain measurement is required, either by Clip on extensometer/s (1" gage recommended) or by two or more strain gages.
Alignment and Bending Stress Check	Strain gaged alignment specimen provided by ORNL. Testing laboratories will check alignment in their systems.
Specimen Dimensions Measurement	Precision Calipers/Micrometers pre and post test. Ultrasound for wall thickness at ORNL
Measured and recorded test data	Applied force and extension/strain as a function of time/X-head movement.
Data Collection	Digital (Force and Extension vs. Time, and Max Force) Suggested collection rate – 40 points per second
Calculated data	Ultimate tensile strength, ultimate tensile strain, Elastic modulus Proportional limit (PL) stress (0.05% offset), PL strain
Fracture Analysis	Done at ORNL

The ILS test package contains the following items

1. Introduction letter
2. Participation agreement to use the specimens only for the axial tensile strength testing and return all test specimens after test. (Appendix 1)
3. Test protocol and instructions (Appendix 2) and a procedure checklist. (Appendix 3)
4. A copy of the ASTM C1773 ATT test method, print (Appendix 4) and PDF file.
5. One test set package with 5 ATT test specimens in each set, ready for testing.
6. An alignment specimen with applied resistance strain gages.
7. The two collet grip fixtures (top and bottom) for the ATT tests.
8. Copper collets and graphite end plugs for the test specimens. (*Reusable copper collets or one set of two for each specimen??*)
9. A CD-ROM with the data report in an MS- EXCEL™ spreadsheet format.
10. A printed copy of the MS- EXCEL™ data spread sheet format for your review. (Appendix 5)

Specific Tasks for the ILS ATT Test Laboratories

The ATT testing of the SiC-SiC tube test specimens will be done by 6 laboratories according to the ASTM C1773 test standard with their in-house testing test equipment, using the supplied grip fixtures, copper collets, and graphite plugs.

The success and value of the ILS effort depends on three factors –

1. All of the CMC ceramic test specimens in each test set are uniform in physical and mechanical properties.
2. All of the participating laboratories prepare their equipment, measure the specimens, and perform the ATT tests according to the ASTM C1773 test standard (App. 4) and the procedure checklist (App. 3).
3. The participating laboratories complete the testing in a timely manner (NLT Jan 31, 2014) and promptly return the Excel spread sheet file with all the formatted test data in the and fractured and unfractured test pieces to the test coordinator.

The specific tasks for the tensile testing laboratories are listed below. These tasks request information beyond the minimum requirements of C1773 to evaluate the robustness of the standard test method.

TASK LIST FOR THE AXIAL TUBE TENSILE TEST ILS STUDY
PACKAGE RECEIPT AND SPECIMEN CHECK
1. Check the test package for completeness -- the ILS instructions, the procedure checklist (App. 3), the ASTM C1773 standard (App. 4), and the included test specimens, grip fixtures, and collets, graphite plugs, and alignment specimen
2. Review the test plan and procedures described in this letter and appendix. Review, sign, and return (e-mail or FAX) the participation agreement (Appendix 2) to Steve Gonczy (gatewaymt@aol.com , FAX 847-870-1624).
3. Check the count and condition of the SiC-SiC specimens in the test set and store them in their original packaging in a dessicator until testing.
4. Check the alignment specimen, the two split collar grip fixtures, the copper collets and the graphite plugs for count and condition. Check how the grip fixtures will be fitted into your test system, accounting for proper alignment.
5. Check that the Excel spread sheet file (ATTT Data.xls) on the CD can be opened.
Specimen Tensile Testing
6. Review the ILS instructions, the procedures checklist (App. 3), and the ASTM C1773 test standard (App. 4).
7. Set up and check the testing equipment for specimen insertion and alignment, force measurement, displacement control, and strain measurement, per the attached checklist (App. 3) and the ASTM C1773 test standard (App. 4)
8. Measure and record outer diameter dimensions (3 measurements at 3 locations in the gage section) of each specimen.
9. Complete 5 valid ATT tests per the attached checklist (App. 3) and the ASTM standard.

10. Measure and record the OD and wall thickness of each specimen at three points around the tube circumference close to the fracture location.
11. Record (in the MS- EXCEL file -- ATTT Data.xls)) and review the specimen data, experimental data, test data, and force-extension/strain for completeness and accuracy. Send the completed data EXCEL spread sheet file by e-mail to Steve Gonczy (gatewaymt@aol.com)
12. Collect, package, and send the fractured test specimens, any unused specimens and completed checklists to Steve Gonczy

Returnables

After the ATT tests are completed, the following items should be returned to the ILS coordinator Steve Gonczy by e-mail and/or postal mail--

1. The fractured test specimens and unused test specimens in their original packaging, and completed checklist for each test set, along with test fixture, mailed to Steve Gonczy at Gateway Materials Technology, 221 S. Emerson, Mt. Prospect, IL.
2. The completed EXCEL spread sheet data file with all laboratory, specimen, test method, and test result data, sent by e-mail to Steve Gonczy (gatewaymt@aol.com)
3. The force-extension/strain data curves for each test specimen in an electronic data format from your 5 tests, sent by e-mail to Steve Gonczy (gatewaymt@aol.com)

Schedule

The tests should be completed and the completed package of data and test pieces should be returned by --

Month DD, YYYY

Contact Points

Technical Contact = Yutai Katoh Oak Ridge National Laboratory Tel : 865-576-5996 E-Mail: katohy@ornl.gov Materials Science and Technology Div. Oak Ridge, TN 37831	Admin Contact = Stephen T. Gonczy Gateway Materials Technology, Inc. Tel: 847-870-1621, E-Mail = gatewaymt@aol.com 221 S. Emerson Mount Prospect, IL 60056
---	--

Your participation in the ILS is much appreciated. We look forward to your contribution of time and effort to this technical project which supports aerospace and nuclear ceramic composites technology and the development of ASTM advanced ceramics standards.

Steve Gonczy
 Gateway Materials Technology
 22 S. Emerson,
 Mount Prospect, IL 60056

Yutai Katoh
 Oak Ridge National Laboratory
 Materials Science and Technology Division
 Oak Ridge, TN 37831

Appendix E3

Axial Tube Tensile Testing Checklist

Return this completed check list with your test data for each test specimen set.

The tasks in the checklist request information beyond the requirements of the draft test standard to evaluate the robustness of the standard test method.

Technical Contact for ATT Testing =
Yutai Katoh, Oak Ridge National Laboratory,
Tel : 865-576-5996 , E-mail: katohy@ornl.gov

Admin Contact for ATT Testing =
Stephen T. Gonczy, Gateway Materials Technology, 847-870-1621, gatewaymt@aol.com

Laboratory Name	
Contact & Phone	
E-Mail Address	
Test Date	
Test Set (circle)	ORNL SiC-SiC 4-14

*The schedule for completing the testing and returning the test pieces to the ILS coordinator Steve Gonczy by **Month DD, YYYY***

There are six sections to this checklist:

- 1 Initial Test Specimen Check and Planning***
- 2 Test Specimen Preparation***
- 3 Equipment Check and Set-up***
- 4 Tensile Testing (Ambient Temperature)***
- 5 Calculation, Data Recording & Review***
- 6 Return Data and Test pieces***

INITIAL TEST SPECIMEN CHECK & TEST PLANNING

<u>Step</u>	<u>Check Box</u>	<u>ACTION</u>	Reference to ASTM C1773
1		Count the number of test specimens against the shipping documents-5 test specimens in the test set) Check each specimen for breaks, surface cracks, or warping. (Call the test coordinator, if the test specimen sets are incomplete or test specimens are broken, cracked, or damaged)	NA
2		Check the legibility of the specimen ID numbers on the test specimen packages.	NA

4	Until ready to do the testing, the specimens should be stored in their original packaging in a desiccator to prevent handling damage and minimize temperature and humidity extremes.	Sec. 9.10
5	Review the ASTM C1773 standard and these ILS instructions.	Test Protocol
6	Review the Excel data reporting spread sheet for format and content.	Test Protocol
7	Determine how the grip fixtures will fit into your test system load train, maintaining alignment and force application.	Test Protocol

TEST SPECIMEN PREPARATION and Measurement

<u>Step</u>	<u>Check Box</u>	<u>ACTION</u>	Reference to ASTM C1773
1.		Open the packaging of the test specimens and check the test specimens and copper collets for damage. If not already installed, Install graphite end plugs into the test specimens	NA Sec 10.4.1
2.		Check the accuracy and calibration of your flat anvil micrometer and your knife edge calipers. <i>Use the micrometer for pre-test OD measurements.</i> <i>Use the calipers for post-test OD and wall thickness measurements.</i>	Sec. 7.3.7 Sec. 7.3.4
3.		Note and record the ID number for each test specimen.	Sec 10.3
4.		Measure and record outer diameter (d_o) of each test specimen at 9 points (3 points around the circumference at three locations (center, center – 25 mm, center + 25 mm) along the gage section length -- 9 measurements)	Sec 10.3.2

Measure and record the overall length of the test specimen and the length of the gage section. (2 measurements)

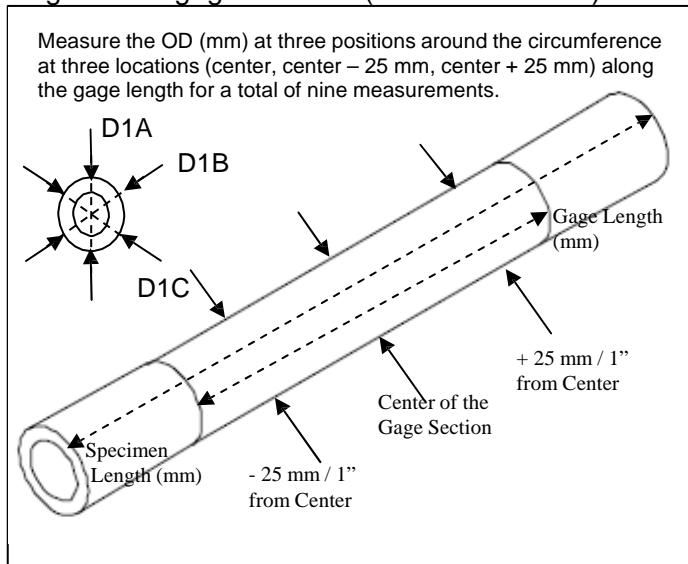

5. If resistance strain gages (12 mm length) are used, install the strain gages per the test standard and record the locations. Sec 7.3.2
Sec 10.3.3
- (Minimum** of 2 strain gages -- at the center of the gage section, 180° apart.
- Preferred** – 4 strain gages-- 2 gages 20 mm down from gage center at 0° and 180° and 2 gages 20 mm up from gage center at 90° and 270°)

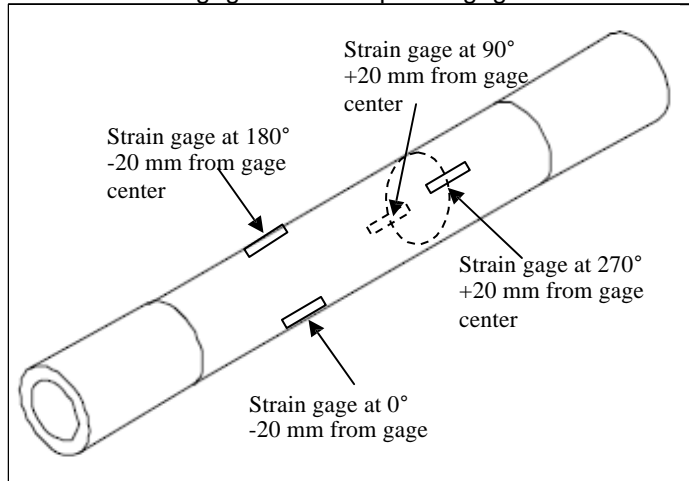

EQUIPMENT CHECK and SET-UP

<u>Step</u>	<u>Check Box</u>	<u>ACTION</u>	Reference to ASTM C1773
1.		Has the testing machine load cell been calibrated to ASTM standards in the last 12 months? If not, calibrate.	Sec. 7.3.7
2.		Can the tensile load cell handle at least 20,000 N (the maximum expected breaking load)? Does the load cell have an accuracy and resolution of ±1% or better at 20,000 N?	Sec. 7.1.4 and 10.2
3.		Are the data recording/acquisition devices calibrated and checked out? Data acquisition rate should be fast enough to capture the resolution of 20 N, i.e. 40 Hz	Sec. 7.3.3 and 10.1
4.		Position, center, and align the top and bottom split-collet grip fixtures.	Sec. 7.2 and 11.2.2.1
5.		With the alignment specimens, check that the load train is properly aligned and that the bending stresses are less than 5%	Sec. 10.5
6.		Set up the strain measurement system for either extensometer or strain gauge	Sec. 10.7

- | | | |
|----|---|-------------------|
| 7. | Set the test control mode for "displacement" and set the cross-head speed for 1 mm/minute, so that failure occurs within 20-30 seconds. | Sec. 7.1 and 11.1 |
|----|---|-------------------|

ATT TESTING

<u>Step</u>	<u>Check Box</u>	<u>ACTION</u>	Reference to ASTM C1773
1.		Check the specimen ID numbers	
2.		Measure and record the ambient temperature and humidity at the beginning of the test session.	Sec 10.11.1
3.		Position and center the first test specimen with the copper collets in the split collet loading fixture. Mark the test specimen for orientation.	Sec 10.6
4.		Strain Measurement -- Mount, connect, and check the extensometer gage on the test specimen. OR Connect and balance the strain gages, if they are used.	Sec 10.7
5.		Activate and and adjust the testing machine for intial cross-head position, zero load, test, mode a cross head speed.	Sec 10.9
6.		Activate and check the data acquisition system.	Sec 10.10 and 10.11.2
7.		Preload the specimen with approximately 20 Newtons to maintain specimen alignment.	Sec 10.11.2
8.		Activate the cross-head movement Record and store the force-strain data for each test.	Sec 10.11.3
9.		Apply force until the test specimen fractures or there is a drop of 50% from the maximum observed force	Sec 10.11.4
10.		Measure and record the breaking / maximum force (Newtons $\pm 1\%$) and the breaking strain (%) against the specimen ID#. Stop the data acquisition Remove the broken specimen segments from the grip fixture. Return the cross-head to the zero position.	Sec 10.11.4 Sec.10.11.5
11.		Note and record if the test is invalid or censored because of failure in the grip sections or outside the gage section.	Sec. 10.12.1

- | | | |
|-----|---|--------------|
| 12. | With the calipers measure and record the OD and wall thickness on each specimen at three points around the circumference close to the fracture point. (3 OD measurements and 6 wall thickness measurements) | Sec. 10.13.1 |
|-----|---|--------------|
-
- | | | |
|-----|--|--------------|
| 13. | Note and record where the fracture location is with respect to the center of the gage section (e.g., 10 mm up or down from the gage center) | Sec. 10.13.2 |
| 14. | Collect and store the fractured test specimen pieces in the original packaging for post-test fractographic examination. Maintain the specimen identification match.. | Sec. 10.13.3 |
| 15. | Repeat steps 3 through 13 for each test specimen in the specimen set. | See above |
| 16. | Measure and record the ambient temperature and humidity at the end of the test session. | Sec 10.11.1 |

CALCULATION, DATA RECORDING AND DATA REVIEW

<u>Step</u>	<u>Check Box</u>	<u>ACTION</u>	Reference to ASTM C1773
1		Using the fracture force (N) and the original cross section area (mm ²) (based on average OD and wall thickness measurements), calculate the axial fracture strength (MPa) (This is done automatically in the EXCEL data sheet).	Sec. 11.4
2		Using the elastic section of the stress-strain curve, calculate and record the tensile elastic modulus (GPa).	Sec. 11.5
3		Using the 0.05% offset method against the elastic section of the stress-strain curve, calculate and record the proportional limit stress (MPa) (0.05% offset) and PL strain(%).	Sec. 11.7
4		Record the test data (experimental parameters, specimen data, and test results) in the Excel spread sheet on the CD. (File = ATTT Data.xls)	Sec 12
5		Review the report test data (test parameters, test specimen data, and test results- Appendix E5) and ensure that data are complete and accurate with no typographical errors.	Sec. 12

- 6 Transfer the force-extension/strain data for each test to the Excel spread sheets, identified by test specimen ID.
- 7 Save the completed Excel data spread sheet (File = ATTDDataSheet.xls)

RETURN DATA AND TEST SPECIMENS

- 1 Send the completed Excel data spreadsheet file to the Steve Gonczy by e-mail. (gatewaymt@aol.com)
- 2 Prepare the test specimen package for shipping with the following--
 - 1 The package with the broken and unused test specimens.
 - 2 A hardcopy of the completed checklist for the test specimen set.
 - 3 A CD with the completed spread sheet file and the force-extension/strain curves.
- 3 Securely package the test data CD and the test specimens and send them to:
Steve Gonczy, Gateway Materials Technology, Inc.
221 S. Emerson
Mt. Prospect, IL 60056
Columbus, IN 47201

*The schedule for completing the testing and returning the test pieces to the ILS coordinator Steve Gonczy by **Month DD, YYYY.***

Appendix E4 – ASTM C1773 Test Standard



Standard Test Method for Monotonic Axial Tensile Behavior of Continuous Fiber-Reinforced Advanced Ceramic Tubular Test Specimens at Ambient Temperature¹

This standard is issued under the fixed designation C1773; the number immediately following the designation indicates the year of original adoption or, in the case of revision, the year of last revision. A number in parentheses indicates the year of last reapproval. A superscript epsilon (ϵ) indicates an editorial change since the last revision or reapproval.

1. Scope

1.1 This test method determines the axial tensile strength and stress-strain response of continuous fiber-reinforced advanced ceramic composite tubes at ambient temperature under monotonic loading. This test method is specific to tube geometries, because fiber architecture and specimen geometry factors are often distinctly different in composite tubes, as compared to flat plates.

1.2 In the test method a composite tube/cylinder with a defined gage section and a known wall thickness is fitted/bonded into a loading fixture. The test specimen/fixture assembly is mounted in the testing machine and monotonically loaded in uniaxial tension at ambient temperature while recording the tensile force and the strain in the gage section. The axial tensile strength and the fracture strength are determined from the maximum applied force and the fracture force. The strains, the proportional limit stress, and the tensile modulus of elasticity are determined from the stress-strain data.

1.3 This test method applies primarily to advanced ceramic matrix composite tubes with continuous fiber reinforcement: uni-directional (1-D, filament wound and tape lay-up), bi-directional (2-D, fabric/tape lay-up and weave), and tri-directional (3-D, braid and weave). These types of ceramic matrix composites are composed of a wide range of ceramic fibers (oxide, graphite, carbide, nitride, and other compositions) in a wide range of crystalline and amorphous ceramic matrix compositions (oxide, carbide, nitride, carbon, graphite, and other compositions).

1.4 This test method does not directly address discontinuous fiber-reinforced, whisker-reinforced or particulate-reinforced ceramics, although the test methods detailed here may be equally applicable to these composites.

1.5 The test method describes a range of test specimen tube geometries based on past tensile testing of ceramic composite

tubes. These geometries are applicable to tubes with outer diameters of 10 to 150 mm and wall thicknesses of 1 to 25 mm, where the ratio of the outer diameter-to-wall thickness (d_o/t) is typically between 5 and 30.

1.5.1 This test method is specific to ambient temperature testing. Elevated temperature testing requires high temperature furnaces and heating devices with temperature control and measurement systems and temperature-capable grips and loading fixtures, which are not addressed in this test standard.

1.6 The test method addresses test equipment, gripping methods, testing modes, allowable bending stresses, interferences, tubular test specimen geometries, test specimen preparation, test procedures, data collection, calculation, reporting requirements, and precision/bias in the following sections.

	Section
Scope	1
Referenced Documents	2
Terminology	3
Summary of Test Method	4
Significance and Use	5
Interferences	6
Apparatus	7
Hazards	8
Test Specimens	9
Test Procedure	10
Calculation of Results	11
Report	12
Precision and Bias	13
Keywords	14
Annexes	
Interferences	Annex A1
Test Specimen Geometry	Annex A2
Grip Fixtures and Load Train Couplers	Annex A3
Allowable Bending and Load Train Alignment	Annex A4
Test Modes and Rates	Annex A5

1.7 *Units*—The values stated in SI units are to be regarded as standard.

1.8 *This standard does not purport to address all of the safety concerns, if any, associated with its use. It is the responsibility of the user of this standard to establish appropriate safety and health practices and determine the applicability of regulatory limitations prior to use. Specific precautionary statements are given in Section 8.*

¹ This test method is under the jurisdiction of ASTM Committee C28 on Advanced Ceramics and is the direct responsibility of Subcommittee C28.07 on Ceramic Matrix Composites.

Current edition approved Feb. 15, 2013. Published April 2013. DOI: 10.1520/C1773-13.

2. Referenced Documents

2.1 ASTM Standards:²

- C1145 Terminology of Advanced Ceramics
- C1239 Practice for Reporting Uniaxial Strength Data and Estimating Weibull Distribution Parameters for Advanced Ceramics
- C1273 Test Method for Tensile Strength of Monolithic Advanced Ceramics at Ambient Temperatures
- C1557 Test Method for Tensile Strength and Young's Modulus of Fibers
- D3878 Terminology for Composite Materials
- D5450 Test Method for Transverse Tensile Properties of Hoop Wound Polymer Matrix Composite Cylinders
- E4 Practices for Force Verification of Testing Machines
- E6 Terminology Relating to Methods of Mechanical Testing
- E83 Practice for Verification and Classification of Extensometer Systems
- E122 Practice for Calculating Sample Size to Estimate, With Specified Precision, the Average for a Characteristic of a Lot or Process
- E251 Test Methods for Performance Characteristics of Metallic Bonded Resistance Strain Gauges
- E337 Test Method for Measuring Humidity with a Psychrometer (the Measurement of Wet- and Dry-Bulb Temperatures)
- E691 Practice for Conducting an Interlaboratory Study to Determine the Precision of a Test Method
- E1012 Practice for Verification of Testing Frame and Specimen Alignment Under Tensile and Compressive Axial Force Application

3. Terminology

3.1 Definitions:

3.1.1 Pertinent definitions, as listed in Terminology C1145, Practice E1012, Terminology D3878, and Terminology E6, are shown in the following with the appropriate source in bold type. Additional terms used in conjunction with this test method are defined in the following:

3.1.2 *advanced ceramic, n*—a highly engineered, high performance predominantly nonmetallic, inorganic, ceramic material having specific functional attributes. **C1145**

3.1.3 *axial strain, n*—the average of the longitudinal strains measured at the surface on opposite sides of the longitudinal axis of symmetry of the test specimen by two strain-sensing devices located at the mid length of the reduced section. **E1012**

3.1.4 *bending strain, n*—the difference between the strain at the surface and the axial strain. In general, the bending strain varies from point to point around and along the reduced section of the test specimen. **E1012**

3.1.5 *ceramic matrix composite, n*—a material consisting of two or more materials (insoluble in one another), in which the major, continuous component (matrix component) is a ceramic,

while the secondary component/s (reinforcing component) may be ceramic, glass-ceramic, glass, metal or organic in nature. These components are combined on a macroscale to form a useful engineering material possessing certain properties or behavior not possessed by the individual constituents. **C1145**

3.1.6 *continuous fiber-reinforced ceramic matrix composite (CFCC), n*—a ceramic matrix composite in which the reinforcing phase consists of a continuous fiber, continuous yarn, or a woven fabric. **C1145**

3.1.7 *fracture (breaking) force, $P_{fracture}$, n*—the force at which the test specimen ruptures, breaking into two or more pieces.

3.1.8 *fracture strength, S_f , n*—the tensile stress at which the test specimen ruptures, breaking into two or more pieces or where the applied force drops off significantly. Typically, a 10 % force drop off is considered significant.

3.1.9 *gage length, l_o , n*—the original length of that portion of the test specimen over which strain or change of length is determined. **E6**

3.1.10 *matrix-cracking stress, n*—the applied tensile stress at which the matrix in the composite cracks into a series of roughly parallel blocks normal to the tensile stress.

3.1.10.1 *Discussion*—In some cases, the matrix cracking stress may be indicated on the stress-strain curve by deviation from linearity (proportional limit) or incremental drops in the stress with increasing strain. In other cases, especially with materials which do not possess a linear portion of the stress-strain curve, the matrix cracking stress may be indicated as the first stress at which a permanent offset strain is detected in the unloading stress-strain (elastic limit).

3.1.11 *modulus of elasticity, E , n*—the ratio of stress to corresponding strains below the proportional limit. **E6**

3.1.12 *modulus of resilience, U_r , n*—strain energy per unit volume required to elastically stress the material from zero to the proportional limit indicating the ability of the material to absorb energy when deformed elastically and return it when unloaded.

3.1.13 *modulus of toughness, U_t , n*—strain energy per unit volume required to stress the material from zero to final fracture indicating the ability of the material to absorb energy beyond the elastic range (that is, damage tolerance of the material).

3.1.13.1 *Discussion*—The modulus of toughness can also be referred to as the cumulative damage energy and as such is regarded as an indication of the ability of the material to sustain damage rather than as a material property. Fracture mechanics methods for the characterization of CFCCs have not been developed. The determination of the modulus of toughness as provided in this test method for the characterization of the cumulative damage process in CFCCs may become obsolete when fracture mechanics methods for CFCCs become available.

3.1.14 *proportional limit stress, σ_o , n*—the greatest stress that a material is capable of sustaining without any deviation from proportionality of stress to strain (Hooke's law). **E6**

² For referenced ASTM standards, visit the ASTM website, www.astm.org, or contact ASTM Customer Service at service@astm.org. For *Annual Book of ASTM Standards* volume information, refer to the standard's Document Summary page on the ASTM website.

3.1.14.1 *Discussion*—Many experiments have shown that values observed for the proportional limit vary greatly with the sensitivity and accuracy of the testing equipment, eccentricity of loading, the scale to which the stress-strain diagram is plotted, and other factors. When determination of proportional limit stress is required, the procedure and sensitivity of the test equipment should be specified.

3.1.15 *percent bending, n* —the bending strain times 100 divided by the axial strain. **E1012**

3.1.16 *slow crack growth, n* —subcritical crack growth (extension) which may result from, but is not restricted to, such mechanisms as environmentally-assisted stress corrosion or diffusive crack growth. **C1145**

3.1.17 *stress corrosion, n* —environmentally induced degradation that results in the formation and growth of cracks and/or damage in glasses and many ceramics when subjected to the combined action of a corroding agent and stress. **C1145**

3.1.17.1 *Discussion*—Such environmental effects commonly include the action of moisture, as well as other corrosive species, often with strong temperature dependence.

3.1.18 *tensile strength, S_u , n* —the maximum tensile stress which a material is capable of sustaining. Tensile strength is calculated from the maximum force during a tension test carried to rupture and the original cross-sectional area of the test specimen. **E6**

3.1.19 *tow, n* —in fibrous composites, a continuous, ordered assembly of essentially parallel, collimated filaments, normally without twist and of continuous filaments. **D3878**

3.1.20 *uniaxial tension, n* —the application of tensile force coaxially with the long dimension of the test specimen.

4. Summary of Test Method

4.1 This test method involves the testing of a ceramic composite tube/cylinder with a known wall thickness in monotonic uniaxial tension at ambient temperature. The prepared test specimen with a defined gage section is fitted/bonded into a loading fixture and the test specimen/ fixture assembly is mounted in the testing machine. The test specimen is loaded in axial tension while recording the applied force and resulting strain. The axial tensile strength S_u and the fracture strength S_f are determined from the maximum applied force and the fracture force. The axial strains, the proportional limit stress, and the tensile modulus of elasticity are determined from the stress-strain response data.

4.2 Tensile strength as used in this test method refers to the tensile strength obtained under monotonic uniaxial loading. In uniaxial loading, the force is applied coaxially with the long dimension of the tube test specimen. Monotonic refers to a continuous nonstop test rate with no reversals from test initiation to final fracture.

4.3 This test method is applicable to a range of test cylinder specimen geometries and sizes, which are described and considered in the test specimen section. A single fixed test specimen geometry cannot be defined because there is a wide range of composite cylinder configurations in use and development. The different described test specimen geometries are

typically applicable to tubes with outer diameters of 10 to 150 mm and wall thicknesses of 1 to 25 mm, where the ratio of the outer diameter-to-wall thickness (d_o/t) is between 5 and 30.

5. Significance and Use

5.1 This test method provides information on the uniaxial tensile properties and tensile stress-strain response of a ceramic composite tube—tensile strength and strain, fracture strength and strain, proportional limit stress and strain, tensile elastic modulus, etc. The information may be used for material development, material comparison, quality assurance, characterization, and design data generation.

5.2 Continuous fiber-reinforced ceramic composites (CFCC) are composed of continuous ceramic-fiber directional (1-D, 2-D, and 3-D) reinforcements in a fine grain-sized (<50 micron) ceramic matrix with controlled porosity. Often these composites have an engineered thin (0.1 to 10 microns) interface coating on the fibers to produce crack deflection and fiber pull-out. These ceramic composites offer high temperature stability, inherent damage tolerance, and high degrees of wear and corrosion resistance. As such, these ceramic composites are particularly suited for aerospace and high temperature structural applications. **(1, 2)³**

5.3 CFCC components have a distinctive and synergistic combination of material properties, interface coatings, porosity control, composite architecture (1-D, 2-D, and 3-D), and geometric shape that are generally inseparable. Prediction of the mechanical performance of CFCC tubes (particularly with braid and 3-D weave architectures) cannot be made by applying measured properties from flat CFCC plates to the design of tubes. Direct uniaxial tensile strength tests of CFCC tubes are needed to provide reliable information on the mechanical behavior and strength of tube geometries.

5.4 CFCCs generally experience “graceful” fracture from a cumulative damage process, unlike monolithic advanced ceramics which fracture catastrophically from a single dominant flaw. The tensile behavior and strength of a CFCC are dependent on its inherent resistance to fracture, the presence of flaws, and any damage accumulation processes. These factors are affected by the composite material composition and variability in material and testing—components, reinforcement architecture and volume fraction, porosity content, matrix morphology, interface morphology, methods of material fabrication, test specimen preparation and conditioning, and surface condition.

5.5 The results of tensile tests of test specimens fabricated to standardized dimensions from a particular material or selected portions of a part, or both, may not totally represent the strength and deformation properties of the entire, full-size end product or its in-service behavior in different environments.

5.6 For quality control purposes, results derived from standardized tubular tensile test specimens may be considered

³ The boldface numbers in parentheses refer to the list of references at the end of this standard.

indicative of the response of the material from which they were taken from, given primary processing conditions and post-processing heat treatments.

6. Interferences

6.1 Interferences in the testing of ceramic composite tubes arise from nine factors—material variability, dimensional variability in the test specimen, test specimen size and volume effects, surface condition variability, fabrication effects, misalignment and bending stresses, gripping and bonding failures, test environment variability, and out-of-gage failures. All of these factors have to be understood and controlled for valid tests. These interference factors are discussed in detail in Annex A1.

7. Apparatus

7.1 *Tensile Testing Machine*, comprised of the following components and illustrated schematically in Fig. 1.

7.1.1 *Fixed Member*—A fixed or essentially stationary member to which one end of the tension specimen/fixture assembly can be attached.

7.1.2 *Movable Member*—A movable member to which the opposite end of the tension specimen/fixture assembly can be attached.

7.1.3 *Drive Mechanism*, for imparting to the movable member a uniform controlled velocity with respect to the fixed member, this velocity to be regulated as specified in 10.2.4 and Annex A5.

7.1.4 *Force/Load Measurement*—A suitable force measurement device capable of showing the total tensile force carried by the test specimen. This device shall be essentially free of inertia-lag at the specified rate of testing and shall indicate the applied force with an accuracy of $\pm 1\%$ or better within the selected force range of the testing machine. The accuracy of the force measurement device shall be verified in accordance with Practice E4.

7.1.5 *Construction Materials*—The fixed member, movable member, drive mechanism, load-train, and fixtures shall be constructed of such materials and in such proportions that the total system compliance of the system contributed by these parts is minimized.

7.2 *Gripping Fixtures*—Various types of gripping devices may be used to transmit the measured force applied by the testing machine to the tubular test specimens. Because of the brittle nature of the matrices of CFCCs, gripping devices must have a uniform, continuous contact with the entire gripped section of the tubular test specimen. (Line contact, point contacts and non-uniform pressure can produce Hertzian-type stresses leading to crack initiation and fracture of the test specimen in the gripped section.) Gripping devices can be classed generally as those employing active grip fixtures and those employing passive grip interfaces as discussed in the following section and in Annex A3.

7.2.1 *Active grip fixtures*—Active grip interfaces use the direct application of a normal gripping force (through

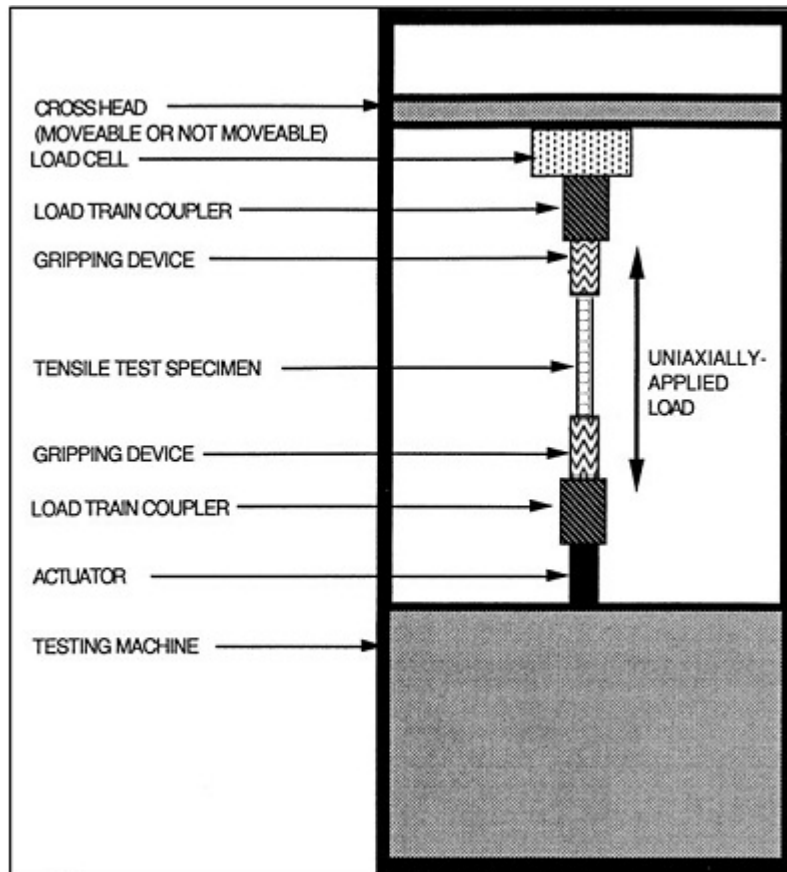

FIG. 1 Tensile Test Apparatus

mechanical, hydraulic, or pneumatic action) to the grip section of the test specimen. These active grips commonly use split circular collets that encircle the outer circumference of the tube and grip the tube through a lateral or wedging action. This gripping action transmits the uniaxial force applied by the test machine by friction between the collet faces and the tubular test specimen. Examples, descriptions, and design/use factors for active grips are discussed in [A3.1](#).

7.2.2 Passive grip fixtures—Passive grip interfaces transmit the force applied by the test machine to the tubular test specimen through a direct adhesive bond into the grips or by mechanical action between geometric features on the test specimen and the grip fixture. Examples, descriptions, and design/use factors for passive grips are discussed in [A3.3](#).

7.2.3 Load train couplers—Various types of devices (load train couplers) may be used to attach the active or passive grip assemblies to the testing machine. The load train couplers in conjunction with the type of gripping device play major roles in the alignment of the load train and minimizing any extraneous bending stresses imposed in the test specimen. Load train couplers can be classified generally as fixed and non-fixed and are discussed in [A3.6](#).

7.2.3.1 Fixed load train couplers—Fixed couplers usually employ concentricity (x,y alignment) and angularity adjusters to minimize load train misalignments. With fixed load train couplers, alignment verification must be performed as discussed in [7.2.4](#) and [Annex A4](#).

7.2.3.2 Fixed load train couplers are preferred in monotonic testing of CFCCs because they maintain a uniform stress across the composite when localized deformation occurs in the test specimen.

7.2.3.3 Non-fixed load train couplers—Non-fixed couplers produce self-alignment of the load train during the movement of the crosshead. Generally the coupling devices rely upon freely moving linkages to eliminate applied moments as the load train components are loaded. Knife edges, universal joints, hydraulic couplers or air bearings are examples of such devices. The operation of the non-fixed couplers must be verified for allowable bending as discussed in [7.2.4](#) and [Annex A4](#).

7.2.4 Allowable Bending and Load Train Alignment—Extraneous and excessive bending stresses from misalignment in uniaxial tensile tests can cause or promote non-uniform stress distributions and premature failure. These bending stresses are minimized by aligning the load train for concentricity and angularity. The tensile test load train shall be properly aligned and verified in all tests.

7.2.4.1 This verification of the alignment and maximum percent bending shall be conducted at a minimum at the beginning and end of each test series. [Annex A4](#) provides additional details on bending issues and alignment methods for CFCCs, along with a detailed procedure for verification of load train alignment, based on [E1012](#).

7.2.4.2 The recommended maximum allowable percent bending at the onset of the cumulative fracture process (for example, matrix cracking stress) for composite test specimens in this test method is five percent (5%).

7.3 Strain Measurement—Strain should be determined by means of either a suitable extensometer or bonded resistance strain gages. If Poisson's ratio is to be determined, the tubular test specimen must be instrumented to measure strain in both axial and circumferential directions.

7.3.1 Extensometers—Extensometers used for tensile testing of CFCC tubular test specimens shall satisfy Test Method [E83](#), Class B-1 requirements. Extensometers are recommended to be used in place of strain gages for test specimens with gage lengths >25 mm and shall be used for high-deformation tests beyond the strain range of strain gages. Extensometers shall be calibrated periodically in accordance with Test Method [E83](#). For extensometers mechanically attached to the test specimen, the attachment should be such as to cause no damage to the specimen surface. In addition, the weight of the extensometer should be supported, so as not to introduce bending stresses in the test specimen greater than that allowed in [7.2.4.2](#).

7.3.2 Strain Gages—Although extensometers are commonly used for CFCC strain measurement, strain can also be determined with bonded resistance strain gages and suitable strain recording equipment. The strain gages, surface preparation, and bonding agents should be chosen to provide adequate performance on the subject materials. Gage calibration certification shall comply with Test Method [E251](#). A general reference on strain gages for composites is Tuttle and Brinson ([15](#)). Some guidelines on the use of strain gages on ceramic composites are as follows.

7.3.2.1 Strain Gage Length—Unless it can be shown that strain gage readings are not unduly influenced by localized strain events such as fiber crossovers, strain gages should not be less than 9 to 12 mm in length for the longitudinal direction and not less than 6 mm in length for the transverse direction. When testing woven fabric composites, the strain gages should have an active gage length that is at least as great as the characteristic unit cell (repeating unit) of the weave; this averages the localized strain effects of the fiber crossovers.

7.3.2.2 Surface Preparation—Many CFCCs have high degrees (>5%) of porosity and surface roughness and therefore require surface preparation (such as surface filling with epoxy) before the strain gages can be applied and fully bonded to the surface. Reinforcing fibers in the composite should not be exposed or damaged during the surface preparation process.

7.3.2.3 Temperature Considerations—Consideration of some form of temperature compensation for the strain gages is recommended, even when testing at standard laboratory atmosphere. Temperature compensation is required when testing in nonambient temperature environments.

7.3.2.4 Transverse Sensitivity—Consideration should be given to the transverse sensitivity of the selected strain gage/s. This is particularly important for a transversely mounted gage used to determine Poisson's ratio, because composites often have markedly different moduli in different directions in the fiber architecture. The strain gage manufacturer should be consulted for recommendations on transverse sensitivity corrections and effects on composites.

7.3.2.5 Poisson's ratio—is easily determined with biaxial (0-90) strain gage rosettes which measure the strain in both the axial and circumferential directions.

7.3.3 *Data Acquisition*—At the minimum, an autographic record of applied tensile force and gage section elongation (or strain) versus time should be obtained. Either analog chart recorders or digital data acquisition systems can be used for this purpose although a digital record is recommended for ease of later data analysis.

7.3.3.1 Recording devices shall be accurate to within ± 0.1 % for the entire testing system including readout unit as specified in Practices E4 and shall have a minimum data acquisition rate of 10 Hz with a response of 50 Hz deemed more than sufficient.

7.3.3.2 Strain or elongation of the gage section, or both, should be recorded either similarly to the force or as independent variables of force. Crosshead displacement of the test machine may also be recorded but should not be used to define displacement or strain in the gage section, especially when self-aligning couplers are used in the load train.

7.3.4 *Dimension Measurement Devices*—Ball or anvil type micrometers should be used for measuring the test specimen inner and outer diameters, to an accuracy of 0.02 mm or 1% of the measured dimension, whichever is greater. Flat anvil type micrometer or calipers of similar resolution may be used for measuring the overall test specimen length and the defined gage length.

7.3.5 *Conditioning Chamber*—When conditioning CFCC materials at non-ambient environments, an environmental conditioning chamber with a controlled temperature and humidity levels is required. The chamber shall be capable of maintaining the required temperature to within $\pm 3^\circ\text{C}$ and the required relative humidity level to within ± 5 %. Chamber conditions shall be monitored either on an automated continuous basis or on a manual basis at regular intervals.

7.3.6 *Environmental Test Chamber*—When testing materials at other than ambient laboratory conditions (high/low humidity and/or high/low temperatures), the environmental chamber shall be capable of maintaining the gage section of the test specimen at the required temperature to within $\pm 3^\circ\text{C}$ and/or the required relative humidity level to within ± 5 %. Chamber conditions shall be monitored during the test either on an automated continuous basis or on a manual basis at regular intervals.

7.3.7 *Calibration and Standardization*—The accuracy of all measuring equipment shall have certified calibrations that are current at the time the equipment is used.

8. Hazards

8.1 During the conduct of this test method, the possibility of flying fragments of broken test material is high. The brittle nature of advanced ceramics and the release of strain energy contribute to the potential release of uncontrolled fragments upon fracture. Means for containment and retention of these fragments for later reconstruction and fractographic analysis is highly recommended. (Plastic shields can be used to encircle the test fixture and to capture specimen fragments.)

8.2 Exposed fibers at the edges of CFCC test specimens present a hazard due to the sharpness and brittleness of the ceramic fiber. All those required to handle these materials should be well informed of such conditions and the proper handling techniques.

9. Test Specimens

9.1 *Geometry Considerations*—CFCC tubes are fabricated in a wide range of sizes and geometries and across a wide spectrum of different reinforcement fibers, distinctive ceramic matrix materials, and markedly different fabrication methods. In addition, the fiber architecture for CFCC tubes has a broad range of configurations with different fiber loadings and directional variations. It is currently not practical to define a single test specimen geometry that is applicable to all CFCC tubes.

9.2 The selection and definition of a tubular test specimen geometry depends on the purpose of the tensile testing effort. For example, if the tensile strength of an as-fabricated component with a defined geometry is required, the dimensions of the resulting tensile specimen may reflect the wall thickness, tube diameter, and length restrictions of the component. If it is desired to evaluate the effects of interactions of various constituent materials for a particular CFCC manufactured via a particular processing route, then the size of the test specimen and resulting gage section will reflect the size and geometry limits of that processing method. In addition, grip devices and load train couplers (as discussed in Section 7 and Annex A3) will influence the final design of the test specimen geometry.

9.3 *Test Specimen Dimensions*—This test method is generally applicable to tubes with outer diameters of 10 to 150 mm and wall thicknesses of 1 to 25 mm, where the ratio of the outer diameter-to-wall thickness (d_o/t) is commonly between 5 and 30.

9.4 *Test Specimen Geometries*—Tubular test specimens are classified into two groups—straight-sided specimens and contoured gage specimens, as shown in Figs. 2 and 3. Contour gage specimens are distinctive in having gage sections with

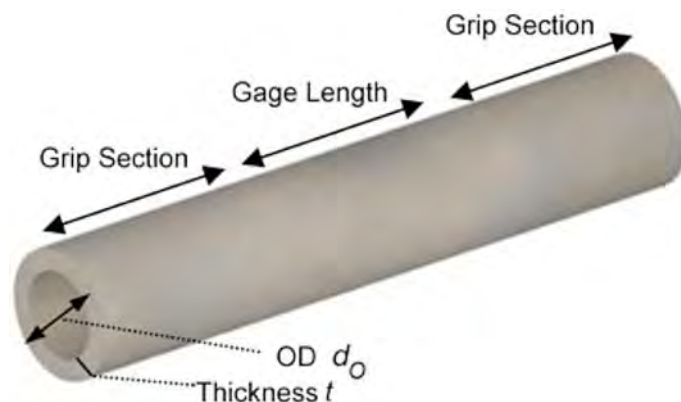

FIG. 2 Schematic of Straight-Sided Tube Specimen

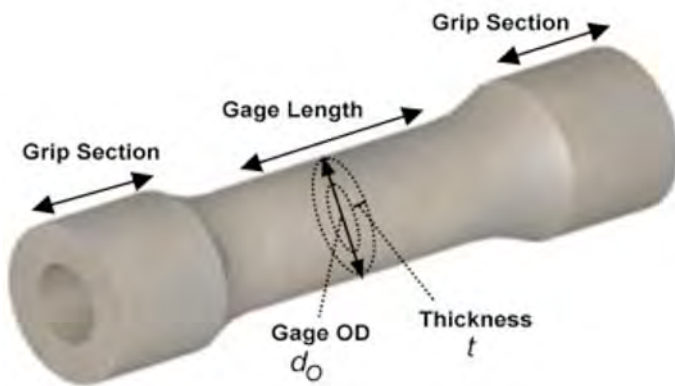

FIG. 3 Schematic of Contoured Gage Section Tube Specimen

thinner wall thicknesses than the gripping sections. Both types of test specimens can be used in active and passive grips.

9.4.1 **Annex A2** provides different examples of straight-sided and contoured gage test specimen tube geometries along with geometry, design, fabrication, and preparation information. However, any CFCC tube geometry is acceptable if fracture failure occurs consistently in the designated gage section with minimal extraneous bending stresses. Deviations from the example geometries are permitted depending upon the particular CFCC tube being evaluated.

9.4.2 Although straight-sided tubular test specimens are easier to fabricate and are commonly used, tube test specimens with contoured gage sections are preferred to promote tensile failure in the uniformly-stressed gage section. The contoured gage sections are formed by integral thick-wall grip sections in the composites or by adhesively-bonded collars/sleeves in the grip sections (**Annex A2**). A key factor in contoured gage section specimens is the minimizing of any stress concentrations at the geometric transitions into the gage sections.

9.5 *Baseline Fabrication*—The composition, architecture, and fabrication processing of the CFCC composite must be well defined and suitably controlled to produce components and test specimens with acceptable, repeatable and uniform physical and mechanical properties. The composition, fiber architecture, fabrication processing, and lot identification should be fully determined and documented.

9.6 *Test Count and Test Specimen Sampling*—A minimum of five valid test specimens is required for the purposes of estimating a mean/average. A greater number of valid test specimens may be necessary, if estimates regarding the form of the strength distribution are required. The procedures outlined in Practice **E122** should be used to estimate the number of tests needed for determining a mean with a specified precision. If material cost or test specimen availability limits the number of possible tests, fewer tests can be conducted to determine an indication of material properties. Test specimens should be selected and prepared from representative CFCC samples that meet the stated testing objectives and requirements. The method of sampling shall be reported.

9.7 *Dimensional Tolerances and Variability*—Dimensional tolerances will depend on the specific selected specimen

geometry, the method of manufacturing, and the performance requirements of the CFCC application. It is common for CFCC tubes to have significant diametral variability (1 to 5 mm) in the as-fabricated condition, particularly for larger diameter tubes. The gage section may or may not be machined to a specific tolerance (**A2.7**). Any significant (>2%) dimensional variability in the OD and ID should be determined and recorded.

9.8 Nondestructive evaluation (ultrasonics, thermal imaging, computerized tomography, etc.) may be used to assess internal morphology (delaminations, porosity concentrations, etc.) in the composite. Record these observations/measurements and the results of any nondestructive evaluations and include them in the final report.

9.9 *Surface Measurement*—In some cases it is desirable, but not required, to measure surface roughness in the gage section to quantify the surface condition. Methods as contacting profilometry can be used to determine surface roughness parallel and perpendicular to the tensile axis across a sufficient area to adequately characterize the surface. When measured, surface roughness should be reported.

9.10 *Test Specimen Storage and Handling*—Care should be exercised in handling, packaging, and storage of finished test specimens to avoid the introduction of random surface flaws. In addition, attention should be given to pre-test storage of test specimens in controlled environments or desiccators to avoid unquantifiable environmental (e.g., humidity) degradation of test specimens prior to testing.

10. Test Procedure

10.1 Any deviation from this test method shall be described in detail in the test report.

10.2 *Test Plan Parameters and Factors*—The following test specimen parameters and experimental test factors have to be defined in detail as part of the test plan.

10.2.1 The test specimen geometry, sampling method, test specimen preparation procedure, and any environmental conditioning and/or test parameters (temperature, humidity, time).

10.2.2 The desired tensile properties and the data reporting format.

10.2.3 An estimate of the tensile properties for the CFCC being tested (tensile strength and strain, modulus of elasticity, etc.). This information is used to determine the required capabilities and range of the test apparatus—load frame, load cells, grips, extensometers, strain gages, etc.

10.2.4 Test modes and rates can have distinct and strong influences on fracture behavior of advanced ceramics even at ambient temperatures depending on test environment or condition of the test specimen. Test modes may involve force, displacement, or strain control. Recommended rates of testing are intended to be sufficiently rapid to obtain the maximum possible tensile strength at fracture of the material. Typically, fracture should occur within 5 to 60 seconds after the start of the test. **Annex A5** describes the different test modes and provides guidance on how to choose a test mode and rate. In all cases the test mode and rate must be reported.

10.2.5 The method of strain measurement (extensometer and/or strain gauge) and the strain measurement plan (type and gage length of extensometer, type and number of strain gauges, locations/ positions, and control/measurement system) should be noted and reported.

10.3 *Test Specimen Preparation*—Test specimen preparation consists of three steps—conditioning, measurement, and strain gauge installation (if used).

10.3.1 *Conditioning*—Condition the test specimens at the desired temperature, humidity, and time, per the test plan.

10.3.2 *Test Specimen Measurement*—Conduct 100 % inspection/measurements of all test specimens for surface condition (cracks, surface flaws, surface porosity, etc.). Note that the frequency of valid gage section fractures and minimal bending in the gage section are dependent on test specimen dimensions being within the desired tolerances.

10.3.2.1 Measure the outer diameter (d_o), the internal diameter (d_i), and/or the wall thickness (t) of the gage section of each test specimen to within 0.02 mm or 1% of the measured dimension, whichever is greater. Make three measurements around the circumference on at least three different cross-sectional planes along the length of the gage section. Record and report the measured dimensions and locations of the measurements for use in the calculation of the tensile stress. Use the average of the multiple measurements in the stress calculations [$d_i = d_o - 2t$].

10.3.2.2 To avoid damage in the gage section area it is recommended that these measurements be made either optically (for example, an optical comparator) or mechanically using a self-limiting (friction or ratchet mechanism) flat, anvil-type micrometer with anvil diameter of at least 5 mm. In all cases the resolution of the instrument shall be as specified in 7.3.4.

10.3.2.3 Exercise caution to prevent damage to the test specimen gage section. Ball-tipped micrometers may be preferred when measuring test specimens with rough or uneven nonwoven surfaces.

10.3.2.4 Alternatively, to avoid damage to the gage section (or in cases where it is not possible to infer or determine gage section wall thickness), use the procedures described in 10.13 to make post-fracture measurements of the gage section dimensions. Note that in some cases, the fracture process can severely fragment the gage section in the immediate vicinity of the fracture thus making post-fracture measurements of dimensions difficult. In these cases, it is advisable to do pretest measurements, per 10.3.2, to assure reliable measurements.

10.3.2.5 Measure and record the overall length of the test specimen and the length of the gage section, if it is defined.

10.3.2.6 If needed, measure the surface finish of the gage section of the test specimens using a suitable method (see 9.7).

10.3.3 *Strain Gage Installation*—Attach strain gages to the test specimen per the strain measurement test plan, ensuring that strain gages are properly oriented and securely bonded to the test specimen per the manufacturer’s instructions. (Strain gage installation can also be done after the test specimen is bonded into the grip fixtures.)

10.4 *Test Specimen Assembly/Fixturing*—Two test specimen factors have to be considered in specimen assembly/fixturing—the use of end plugs and the method of adhesive bonding.

10.4.1 *End Plugs*—End plugs may be used in active gripping to prevent collapse in the grip sections. If end plugs (A3.2) are being used in the test (for active gripping), insert and bond the two end plugs into the test specimen, using the designated adhesive and alignment procedure. Ensure that the end plugs are centered in the test specimen and at the proper depth. Cure the adhesive per the manufacturer’s specifications.

10.4.2 *Adhesive Bonding into the Grip Fixtures*—If adhesive bonding grip fixtures are being used (Annex A3), the test specimen should be secured into the two end fixtures by filling the fixture cavities with the adhesive material (prepared per the manufacturer’s instructions). Position the test specimen into the two grip fixtures and use an alignment fixture to ensure that the two end fixtures and the test specimen are aligned concentrically. Cure the adhesive per the manufacturer’s specifications. After curing, measure the free length/distance between the end fixtures at four points at 90° intervals around the specimen/fixture circumference. Significant deviations (>2%) in the measured length are an indication of test specimen or grip section misalignment.

10.5 *Load Train Alignment and Bending Stress Assessment*—If load train alignment is done with a “dummy” specimen, adjust/verify the alignment of the load train, per the guidance in 7.2.4 and Annex A4.

10.6 *Test Specimen Insertion*—Each grip system and test specimen geometry (as described in Section 7, Annex A2 and Annex A3) will require a unique procedure for mounting the test specimen in the load train. If special fixture components are required for each test, these should be identified and noted in the test report.

10.6.1 Mount the test specimen/assembly into the grips and load train, ensuring that the test specimen is properly positioned and aligned in the grips. Tighten the grips evenly and firmly to the degree necessary to prevent slippage of the test specimen during the test but not to the point where the specimen would be crushed.

10.6.2 If strain gages are used to monitor bending, the strain gages should be zeroed with the test specimen attached at only one end, so that it is hanging free. This will ensure that bending due to the grip closure is factored into the measured bending.

10.6.3 If load train alignment is done with the actual test specimen, adjust/verify the alignment of the load train, per the guidance in 7.2.4 and Annex A4.

10.6.4 Mark the test specimen with an indelible marker as to top and bottom and front (side facing the operator) in relation to the test machine. In the case of strain-gaged test specimens, orient the test specimen such that the “front” of the test specimen and a unique strain gage coincide (for example, Strain Gage 1 designated SG1).

10.7 *Extensometers and Strain Gages*—Mount/connect the extensometer/s on the test specimen, if an extensometer is being used. Connect the lead wires of any strain gages to the

conditioning equipment and allow the strain gages to equilibrate under power for at least 30 min prior to conducting the verification tests. This will minimize drift during the test.

10.8 *Test Environment*—If an environmental test chamber is being used, condition the test specimen at the defined temperature and humidity for the designated period of time. Record the environmental conditions and the “time to equilibrium” for each test.

10.9 *Testing Machine Set Up*—Activate and adjust the testing machine for initial cross-head position, zero load, and desired test mode and test rate. Set the mode and speed of testing, so that the failure occurs in less than 60 seconds, using the guidance in [Annex A5](#).

10.10 *Data Collection Equipment*—Assemble and activate the data recording instrumentation for force and strain, setting the range, sensitivity, and recording/data collection rate.

10.11 The tensile test is conducted in the following sequence.

10.11.1 Determine and record the ambient temperature and the relative humidity in accordance with Test Method [E337](#).

10.11.2 Initiate the data acquisition. Preload the test specimen to the designated force level, if necessary.

10.11.3 Initiate the primary test mode and record force versus strain (or displacement) continuously.

10.11.4 Load the test specimen to fracture failure. Record the maximum force, the fracture force, and the corresponding strain (or extension). Fracture is marked by specimen breakage and separation or where the applied force drops off significantly. Typically, a 10 % force drop off is considered significant. The maximum force and the fracture force should be measured within ± 1.0 % of the force range and noted for the report.

10.11.5 After specimen fracture, disable the action of the test machine and the data collection of the data acquisition system. Carefully remove the test specimen halves from the grips. Take care not to damage the fracture surfaces by preventing them from contact with each other or other objects. Place the test specimen halves along with other fragments from the gage section into a suitable, protective package/container for later analysis.

10.12 *Invalid and Censored Tests*—A valid individual test is one which meets all the following requirements—all the testing requirements of this test method are met and final fracture occurs in the uniformly-stressed gage section.

10.12.1 Fracture/failure occurring in the grip sections is an invalid test. Failure outside the designated gage section and within one specimen diameter of the grip/bond boundary on the specimen and the test fixture may be a grip failure, and should be considered as a censored test.

10.12.1.1 Note that results from test specimens fracturing outside the uniformly stressed gage section are not recommended for use in the direct calculation of an average/mean tensile strength or fracture strength for the entire test set. Results from test specimens fracturing outside the gage section (or outside the extensometer gage length of straight-sided test specimens) are considered anomalous and can be used only as censored tests (that is, test specimens in which a tensile stress

at least equal to that calculated by [Eq 4](#) was sustained in the uniform gage section before the test was prematurely terminated by a non-gage section fracture) as discussed in Practice [C1239](#) for the determination of estimates of the strength distribution parameters. From a conservative standpoint, in completing a required statistical sample (for example, $N = 5$) for purposes of average strength, test one replacement test specimen for each test specimen that fractures outside the gage section.

10.12.2 A significant fraction ($>10\%$) of invalid and/or censored failures in a sample population shall be cause to re-examine the means of force introduction into the material. Factors of concern that can produce invalid tests include the alignment of the test specimen in the fixture, alignment of the fixtures in the grips, collar materials, and the adhesive used to bond the test specimen to the fixture.

10.13 *Post-Test Measurement and Analysis:*

10.13.1 *Dimensions*—Measure and report the the gage section OD and ID dimensions at the fracture location to ± 0.02 mm, if the gage section has not been overly fragmented by the fracture process. Use these post-test dimension measurements to calculate the stresses in Section [11](#). If a post-test measurement of the OD and ID dimensions cannot be made due to fragmentation, then use the average dimensions measured in [10.3.2](#).

10.13.2 *Fracture Location*—Measure and report the fracture location relative to the midpoint of the gage section. The convention used should be that midpoint of the gage section is 0 mm with positive (+) measurements toward the top of the test specimen as tested (and marked) and negative (–) measurements toward the bottom of the test specimen as tested (and marked).

10.13.3 *Post-test Fractographic Examination*—Visual examination and light microscopy of the fracture surfaces should be conducted to determine the mode and type of fracture (that is, brittle or fibrous) as a function of composite composition and architecture, material variability, damage accumulation, and failure zones. In addition, subjective observations can be made of the length of fiber pullout, fracture plane orientation, degree of interlaminar fracture, and other pertinent details of the fracture surface. The results of the fractographic analysis should be reported.

11. Calculation of Results

11.1 *Discussion of stress-strain responses for different CFCCs (graphs)*—Various types of CFCC material, due to the nature of their constituents, processing routes, and prior mechanical history, may exhibit vastly different stress-strain responses as illustrated schematically in [Fig. 4\(a\),\(b\),and\(c\)](#). Therefore, interpretation of the test results will depend on the type of response exhibited. Points corresponding to the following calculated values are shown on the appropriate diagrams.

NOTE 1—At the high strain portions of the curves, two different possible behaviors are depicted: cases where stress drops prior to fracture (solid line) and cases where stress continues to increase to the point of fracture (dashed line).

11.2 *Engineering stress and strain calculation*—Calculate the engineering stress as:

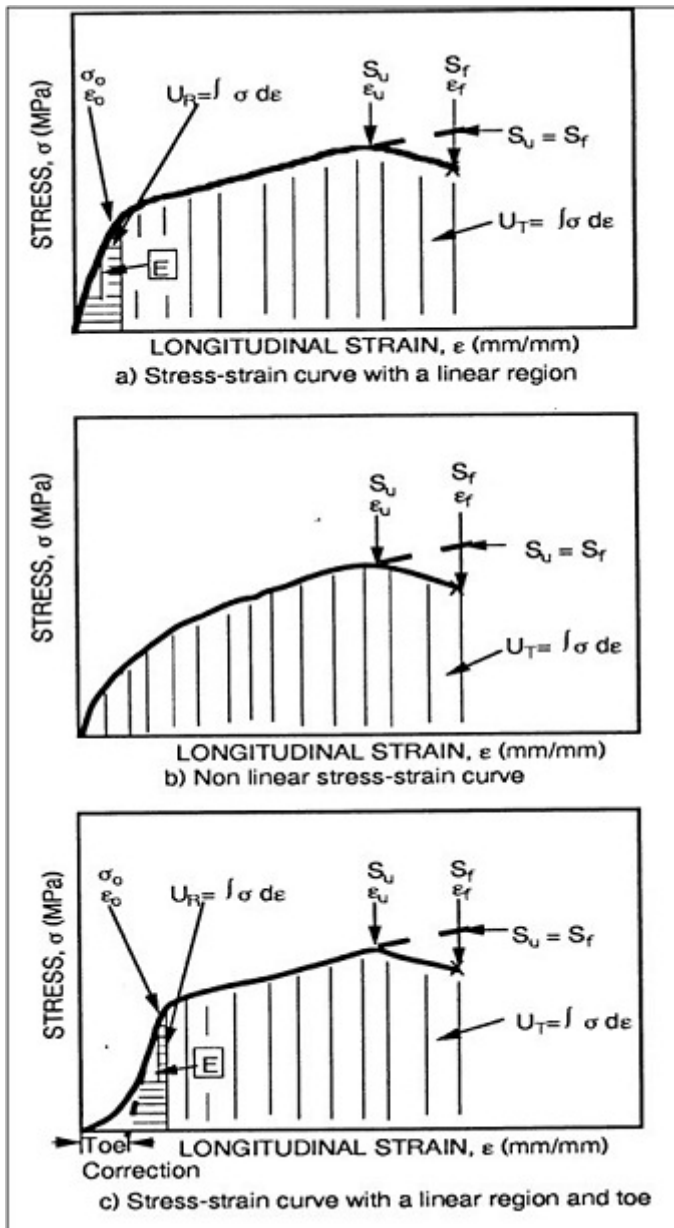

FIG. 4 Examples (a, b, c) of CFCC Stress-Strain Curves

$$\sigma = P/A \quad (1)$$

where:

- σ = the engineering stress in units of MPa,
- P = the applied, uniaxial tensile force at any time in units of N , and
- A = the original cross-sectional area of the test specimen in units of mm^2 .

The cross-sectional area A of the tube specimen is calculated as:

$$A = \frac{\pi(d_o^2 - d_i^2)}{4} = \pi t(d_o - t) \quad (2)$$

where:

- d_o = the average outer diameter of the gage section in units of mm as detailed in 10.3.2 or 10.13.1,

- d_i = the average inner diameter of the gage section in units of mm as detailed in 10.3.2 or 10.13.1, and
- t = the average wall thickness of the gage section in units of mm as detailed in 10.3.2 or 10.13.1.

11.2.1 Engineering Strain Calculation:

11.2.1.1 *Extensometer Strain Calculation*—For strain measurement by extensometer, calculate the engineering strain as:

$$\epsilon_{xx} = (l - l_o)/l_o \quad (3)$$

where:

- ϵ_{xx} = the engineering strain (no dimensions), either axial (ϵ_{11}) or transverse (ϵ_{22}) based on the orientation of the extensometer,
- l = the gage length (extensometer gage length) at any time in units of mm, and
- l_o = the original/extensometer gage length in units of mm.

11.2.1.2 *Strain Gage Calculation*—If bonded strain gages are being used, the appropriate strain values are obtained independently of the test specimen gage length. The average principal strains [axial (ϵ^a_{11}) and/or circumferential (ϵ^a_{22})] are calculated in the following three step process.

- (1) Correct the experimental strain gage readings (ϵ^x_{11} and/or ϵ^x_{22}) for transverse sensitivity for each strain gage (single or rosette) to give the corrected strain gage readings (ϵ^c_{11} and/or ϵ^c_{22})
- (2) Calculate separately the principal strains (ϵ^i_{11} and/or ϵ^i_{22}) for each strain gage (single or rosette) using the transverse corrected strain gage readings.
- (3) Calculate the average principal strains (ϵ^a_{11} and/or ϵ^a_{22}) in the test specimen by taking the average of the principal strains (ϵ^i_{11} and/or ϵ^i_{22}) from all the mounted strain gages.

(See ASTM D5450 Section 12 for a full description of strain calculation with multiple strain gages.)

11.2.1.3 Note that in some cases the initial portion of the stress-strain ($\sigma - \epsilon$) curve shows a nonlinear region or “toe” followed by a linear region as shown in Fig. 4(c). This toe may be an artifact of the test specimen or test conditions (for example, straightening of a warped test specimen) and thus may not represent a property of the material. The $\sigma - \epsilon$ curve can be corrected for this toe by extending the linear region of the curve to the zero-stress point on the strain axis as shown in Fig. 4(c). The intersection of this extension with the strain axis is the toe correction that is subtracted from all values of strain greater than the toe correction strain. The resulting $\sigma - \epsilon$ curve is used for all subsequent calculations.

11.3 Axial Tensile Strength and Strain Calculation:

11.3.1 Calculate the axial tensile strength using the following equation as:

$$S_u = P_{max}/A \quad (4)$$

where:

- S_u = the tensile strength in units of MPa,
- P_{max} = the maximum force prior to failure in units of N , and
- A = the original cross-sectional area in the gage section, $\pi(d_o^2 - d_i^2)/4 = \pi t(d_o - t)$ in units of mm^2 .

11.3.1.1 Determine the axial strain at tensile strength, ϵ_u , as the axial engineering strain (ϵ_{11}) corresponding to the tensile strength measured during the test.

11.4 Axial Fracture Strength And Strain Calculation:

11.4.1 Calculate the axial fracture strength using the following equation as:

$$S_f = P_{fracture} / A \quad (5)$$

where:

- S_f = the fracture strength in units of MPa,
- $P_{fracture}$ = the fracture force (breaking force) when the test specimen separates into two or more pieces, in units of N, and
- A = the original cross-sectional area in the gage section, $\pi(d_o^2 - d_i^2)/4 = \pi t(d_o - t)$ in units of mm^2 .

In some instances the tensile strength and the fracture strength are equal ($S_u = S_f$) as shown by the dashed line in Fig. 4(a), (b), and (c).

11.4.2 Determine axial strain at fracture strength, ϵ_f , as the axial engineering strain (ϵ_{11}) corresponding to the fracture strength measured during the test. In some instances as shown by the dashed line in Fig. 4(a), (b), and (c), $\epsilon_u = \epsilon_f$.

11.5 Elastic Tensile Modulus—Calculate the modulus of elasticity as follows:

$$E = \Delta\sigma / \Delta\epsilon \quad (6)$$

where E is the modulus of elasticity and $\Delta\sigma / \Delta\epsilon$ is the slope of the $\sigma - \epsilon$ curve within the linear region as shown in Fig. 4(a) and (c). Note that the modulus of elasticity may not be defined for materials that exhibit entirely non-linear $\sigma - \epsilon$ curves as shown in Fig. 4(b).

11.6 Poisson's Ratio—Calculate the Poisson's ratio (if circumferential strain is measured) as follows:

$$\nu = -\Delta\epsilon_{22} / \Delta\epsilon_{11} \quad (7)$$

where ν is Poisson's ratio, and $\Delta\epsilon_{22} / \Delta\epsilon_{11}$ is the slope of the linear region of the plot of circumferential strain ϵ_{22} versus axial strain, ϵ_{11} . Note that Poisson's ratio may not be defined for materials which exhibit non-linear $\sigma - \epsilon$ curves over the entire history as shown in Fig. 4(b) (although this must be verified by plotting ϵ_{22} versus ϵ_{11} to determine whether or not a linear region exists.)

11.7 Proportional Limit Stress and Strain Calculation—Determine the proportional limit stress, σ_o , by one of the following methods. Note that by its definition the proportional limit stress, σ_o , may not be defined for materials that exhibit entirely non-linear $\sigma - \epsilon$ curves as shown in Fig. 4(b).

11.7.1 Offset Method—Determine σ_o by generating a line running parallel to the same part of the linear part of the $\sigma - \epsilon$ curve used to determine the modulus of elasticity in 11.5. The line so generated should be at a strain offset of 0.05% (0.0005 mm/mm). The proportional limit stress is the stress level at which the offset line intersects the $\sigma - \epsilon$ curve. See Fig. 5 for a graphical illustration of this technique.

NOTE 2—In some CFCC materials with low fracture strain values (<1%) and relatively steep second-stage stress-strain slopes, an offset strain of 0.05% is too large and gives an inaccurate assessment of the

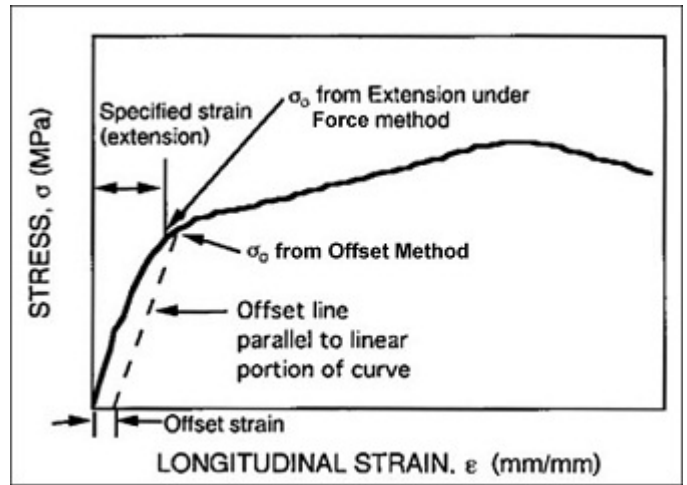

FIG. 5 Schematic Diagram of Methods for Determining the Proportional Limit Stress and Strain

proportional limit stress. In such cases, an alternate offset strain value should be defined and reported to give an accurate value for the proportional limit stress. As an example, some researchers use a 5% calculation to determine an offset strain, shown as follows:

Offset strain (%) = 5% × (nominal proportional limit stress) / (elastic modulus). Fig. 6 shows a stress-strain curve with 0.01% and 0.05% strain offsets to determine the proportional limit stress.

11.7.2 Extension Under Force Method—Determine σ_o by noting the stress on the $\sigma - \epsilon$ curve that corresponds to a specified strain. The specified strain may or may not be in the linear region of the $\sigma - \epsilon$ but the specified strain at which σ_o is determined must be constant for all tests in a set with the specified strain reported. See Fig. 5 for a graphical illustration of this technique.

11.7.3 Deviation From Linearity Method—Determine σ_o by noting the stress σ_i , on the $\sigma - \epsilon$ curve at which there is a specified percent deviation (for example, %dev = 10) from the stress calculated from the elastic relation, $\sigma = E\epsilon_i$ such that:

$$\%dev = 100 \left[\frac{(E\epsilon_i) - \sigma_i}{\sigma_i} \right] \quad (8)$$

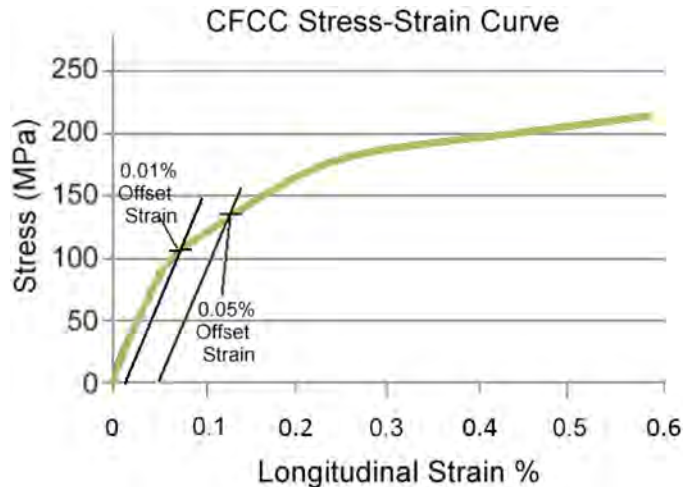

FIG. 6 CFCC Stress-Strain Curve with Two Offset Strain Values

where:

σ_i and ε_i = the i -th stress and corresponding strain, respectively, on the $\sigma - \varepsilon$ curve, and
 E = the axial modulus of elasticity.

The proportional limit stress is determined, such that $\sigma_o = \sigma_i$ when %dev first equals or exceeds the specified value when evaluating increasing σ_i and ε_i starting from zero.

11.7.4 *Strain at Proportional Limit Stress*—Determine the strain at proportional limit stress, ε_o , as the strain corresponding to the proportional limit stress determined for the test.

11.8 *Modulus of Resilience (U_R)*—Calculate the modulus of resilience as the area under the linear part of the $\sigma - \varepsilon$ curve or alternatively estimated as:

$$U_R = \int_0^{\varepsilon_o} \sigma d\varepsilon \approx \frac{1}{2} \sigma_o \varepsilon_o \quad (9)$$

where:

U_R = the modulus of resilience in J/m^3 , and σ_o and ε_o as used in Eq 11 have units of Pa (that is, N/m^2) and mm/mm, respectively.

11.9 *Modulus of Toughness (U_T)*—Calculate the modulus of toughness as the area under the entire $\sigma - \varepsilon$ curve or alternatively estimated as:

$$U_T = \int_0^{\varepsilon_f} \sigma d\varepsilon \approx \frac{\sigma_o + S_u}{2} \varepsilon_f \quad (10)$$

where U_T is the modulus of toughness in J/m^3 , and σ_o and S_u as used in Eq 12 have units of Pa (that is, N/m^2) and ε_o has units of mm/mm.

NOTE 3— U_T can be estimated as follows for materials for which σ_o is not calculated and that have a $\sigma - \varepsilon$ curve that can be assumed to be a parabola:

$$U_T = \int_0^{\varepsilon_f} \sigma d\varepsilon \approx \frac{2}{3} S_u \varepsilon_f \quad (11)$$

The modulus of toughness can also be referred to as the cumulative damage energy and as such is regarded as an indication of the ability of the material to sustain damage rather than as a material property. Fracture mechanics methods for the characterization of CFCCs have not been developed. The determination of the modulus of toughness as provided in this test method for the characterization of the cumulative damage process in CFCCs may become obsolete when fracture mechanics methods for CFCCs become available.

11.10 *Statistics—Mean, standard of deviation, coefficient of variation*—For each series of tests the mean, standard deviation, and coefficient of variation for each measured value can be calculated as follows:

X = the measured value and n = the number of valid tests.

$$\text{mean} = \bar{X} = \frac{\sum_{i=1}^n X_i}{n} \quad (12)$$

$$\text{standard deviation} = s.d. = \sqrt{\frac{\sum_{i=1}^n (X_i - \bar{X})^2}{n - 1}} \quad (13)$$

$$\text{Percent Coefficient of Variation} = CV = \frac{100(s.d.)}{\bar{X}} \quad (14)$$

X = the measured value and n = the number of valid tests.

12. Report

12.1 *Testing Information*—Report the following information for the test set. Any significant deviations from the procedures and requirements of this test method should be noted in the report.

12.2 Location, date of test and test operators.

12.3 *Material and Test Specimen Description*:

12.3.1 *Test Material*—source, fiber material and description, matrix material and description, reinforcement architecture, method of fabrication, material specifications and designations, lot #, date of fabrication.

12.3.2 All relevant material data including vintage data or billet identification data. (Did all test specimens come from one billet or processing run?) At a minimum, the date the material was manufactured must be reported. For commercial materials, the commercial designation must be reported. At a minimum include a short description of reinforcement (type, layup, etc.), fiber volume fraction, porosity fraction, and bulk density.

12.3.3 For non-commercial materials, the major constituents and proportions should be reported as well as the primary processing route including green state and consolidation routes. Also report fiber volume fraction, matrix porosity, and bulk density. The reinforcement type, properties and reinforcement architecture should be fully described to include fiber properties (composition, diameter, source, lot number and any measured/specified properties), interface coatings (composition, thickness, morphology, source, and method of manufacture) and the reinforcement architecture (yard type/count, thread count, weave, ply count, fiber areal weight, stacking sequence, ply orientations, etc.).

12.3.4 Test specimen geometry and dimensions, with a description of end collars and/or end plugs (if used)—a drawing of the collar/plug, the collar/plug material, and the adhesive used.

12.3.5 Description of the method of test specimen preparation including all stages of machining, surface finishing, dimensional measurement, and the surface measurement values, if done.

12.3.6 Heat treatments, coatings, or conditioning exposures, if any applied either to the as-processed material or to the as-fabricated test specimen.

12.4 *Equipment and Test Parameters*:

12.4.1 Testing Machine Type and configuration of the test machine (include drawing or sketch if necessary). If a commercial test machine was used, the manufacturer and model number are sufficient for describing the test machine.

12.4.2 *Force Measurement Description*—Type, Range, Resolution and Accuracy of the force measurement device.

12.4.3 Type and configuration of grip interface used (include drawing or sketch if necessary). If a commercial grip interface was used, the manufacturer and model number are sufficient for describing the grip interface.

12.4.4 Type and configuration of load train couplers (include drawing or sketch if necessary). If a commercial load

train coupler was used, the manufacturer and model number are sufficient for describing the coupler.

12.4.5 *Strain Measurement Description*—Type, configuration, and resolution of strain measurement equipment used (include drawing or sketch if necessary). If a commercial extensometer or strain gages were used, the manufacturer and model number are sufficient for describing the strain measurement equipment.

12.4.6 Test environment including relative humidity (E337), ambient temperature, and atmosphere (for example, ambient air, dry nitrogen, silicone oil, etc.) and soak times.

12.4.7 Test mode (strain, displacement, or load control) and actual test rate (strain rate, displacement rate, or force rate). Calculated strain rate should also be reported, if appropriate, in units of s^{-1} .

12.4.8 Percent bending and corresponding average strain in the test specimen recorded during the verification as measured at the beginning and end of the test series.

12.5 Test Results:

12.5.1 Number of valid, invalid, and censored tests.

12.5.2 Mean, standard deviation, and COV statistics for valid tests, as follows:

12.5.2.1 Tensile Strength and Strain.

12.5.2.2 Fracture Strength and Strain.

12.5.2.3 Elastic Modulus, if measured.

12.5.2.4 Poisson's ratio, if measured.

12.5.2.5 Proportional limit stress σ_o (if measured), and method of determination, including the selected offset-strain value. expressed as "0.XX% offset proportional limit stress".

12.5.2.6 Modulus of Resilience, if measured.

12.5.2.7 Modulus of Toughness, if measured.

12.6 Data for Individual Test Specimens:

12.6.1 Measured Dimensions (OD, ID, wall thickness, Gage Length), average of measured dimensions, and calculated cross sectional area.

12.6.2 Tensile Strength and Strain.

12.6.3 Fracture Strength and Strain.

12.6.4 Modulus of Elasticity, if measured.

12.6.5 Poisson's ratio, if measured.

12.6.6 Proportional limit stress σ_o (if measured), and method of determination, including the selected offset-strain value. expressed as "0.XX% offset proportional limit stress".

12.6.7 Modulus of resilience, if measured.

12.6.8 Modulus of toughness, if measured.

12.6.9 Fracture location, mode of fracture, and fracture surface appearance.

12.6.10 Stress-Strain or Force-Extension data and curves.

13. Precision and Bias

13.1 *Statistical mechanical properties and material variability*—The tensile behavior of a ceramic composite is not deterministic, but commonly varies significantly from one test specimen to another. Sources of this variability are inherent variations in ceramic composites fabricated with ceramic fiber reinforcements and ceramic matrices. As described in A1.1, the following variations in the following CFCC properties and morphology may have effects on the precision of this test method—fiber properties, interface coatings, fiber alignment and architecture, matrix properties porosity fraction/size/distribution, and/or internal flaws. Such variations can occur spatially within a given test specimen, as well as between different test specimens.

13.2 *Test factors affecting precision*—As described in Section 6 and Annex A1, precision can be affected by dimensional (wall thickness) variability in the test specimen/s, surface condition/damage of the test specimens, volume/size effects in the test specimen, bending stresses in the load train, temperature/ moisture effects, loading rate, precision of the load cell and the strain measurement systems.

13.3 *Precision and Bias*—Because of the nature of the materials and lack of a wide data base on a variety of advanced ceramic composite tubes tested in tension, no definitive statement can be made at this time concerning precision and bias of the test procedures of this test method.

13.4 *Interlaboratory Test Program*—Committee C28 is currently planning an interlaboratory testing program per E691 to determine the precision (repeatability and reproducibility) for this test method.

14. Keywords

14.1 ceramic matrix composite; continuous ceramic fiber composite; cylinders; elastic modulus; modulus of resilience; modulus of toughness; Poisson's ratio; tensile strength; tubes

ANNEXES

(Mandatory Information)

A1. INTERFERENCES

A1.1 Material Variability—Ceramic composites by their nature are combinations of different materials with engineered variability in the spatial distribution of constituents, as well as anisotropy in fiber architecture. These variations result in anisotropic material properties. There is also often variability in matrix and fiber properties, fiber alignment, fabrication methods, the morphology of interface coatings, and porosity fraction/size/distribution within test specimens and between test specimens. All of these variables are possible causes of material data variability between test specimens and in lot-to-lot comparison.

A1.2 Dimensional Variability in the Test Specimen—The fabrication methods for CFCC tubes may produce significant variations in the as-fabricated wall thickness along the specimen length. These variations are commonly retained in the testing of “as-prepared” test specimens, and they are a source of dimensional variation and non-uniform stress distributions within the test specimen.

A1.3 Test Specimen Size and Volume Effects—CFCCs generally experience “graceful” fracture from a cumulative damage process, unlike monolithic advanced ceramics which fracture catastrophically from a single dominant flaw. Therefore, the volume of material subjected to a uniform tensile stress for a single uniaxial-loaded tensile test may not be as significant a factor in determining the ultimate strengths of CFCCs. However, the need to test a statistically significant number of tubular tensile test specimens is not obviated.

A1.3.1 Because of the probabilistic nature of the strength distributions of the brittle matrices of CFCCs, a sufficient number of test specimens at each testing condition is required for statistical analysis and design.

A1.3.2 Studies to determine the exact influence of test specimen volume on strength distributions for CFCCs have not been completed. It should be noted that tensile strengths obtained using different test specimen tube geometries with different volumes of material in the gage sections may be different due to these volume differences.

A1.4 Surface Condition of the Test Specimen—Surface preparation of test specimens, although normally not considered a major concern in CFCCs, can introduce surface flaws and damage that may have pronounced effects on tensile mechanical properties and behavior (for example, shape and level of the resulting stress-strain curve, tensile strength and strain, proportional limit stress and strain, etc.). (See [Annex A2](#) for a discussion of surface preparation.)

A1.5 Material and Test Specimen Fabrication Effects—The nature of fabrication used for certain composites (for example, chemical vapor infiltration or hot pressing) may require the testing of test specimens in the as-processed condition (that is, it may not be possible to machine the test specimen surfaces).

A1.5.1 Test specimen fabrication and surface machining history may play an important role in the measured strength distributions and should be reported.

A1.6 Bending Stresses and System Alignment—Extraneous and excessive bending stresses in uniaxial tensile tests can cause or promote non-uniform stress distributions and premature failure, with maximum stresses occurring at the test specimen surface. This leads to non-representative fractures originating at surfaces or near geometric transitions. Similarly, fracture from surface flaws may be accentuated or suppressed by the presence of the non-uniform stresses caused by bending. Bending may occur due to misaligned grips, misaligned specimens in the test fixtures, or from departures of the test specimen from tolerance requirements. The alignment in the load train should always be checked and adjusted as discussed in [7.2.4](#) and [Annex A4](#) to eliminate excess bending from the test system.

A1.7 Gripping and Bonding Failures—A high percentage of failures in the test specimen at or near the test specimen grips, especially when combined with high material data scatter, is an indicator of specimen bonding problems (whether mechanically gripped or adhesively bonded). For gripping systems, grip pressure is a key variable in the initiation of fracture. Insufficient pressure can shear the outer plies in laminated CFCCs or produce slip between the grips and the specimen; while too much pressure can cause local crushing of the CFCC and fracture in the vicinity of the grips. Specimen gripping and bonding are discussed in [7.2](#) and [Annex A3](#).

A1.8 Test Environment and Parameters—CFCCs commonly exhibit non-linear stress-strain behavior which is the result of cumulative damage processes (for example, matrix cracking, matrix/fiber debonding, fiber fracture, delamination, etc.). Some of these damage processes may be the consequence of stress corrosion or subcritical (slow) crack growth. Test environment (vacuum, inert gas, ambient air, relative humidity) may have an influence on the damage processes and the measured tensile strength. In particular, the behavior of materials susceptible to slow crack growth fracture may be strongly influenced by test mode, test rate and test environment. Testing to evaluate the maximum strength potential of a material

should be conducted in inert environments or at sufficiently rapid testing rates, or both, so as to minimize slow crack growth effects. Often these effects can be minimized by testing at sufficiently rapid rates, so that failure occurs in less than 60 seconds.

A1.8.1 When testing is conducted in uncontrolled ambient air with the intent of evaluating maximum strength potential, relative humidity and temperature must be monitored and reported. Testing at humidity levels >65 % relative humidity (RH) is not recommended and any deviations from this recommendation must be reported.

A1.8.2 Testing to evaluate the maximum strength potential of a moisture-sensitive material should be conducted in inert environments or at sufficiently rapid testing rates, or both, so as to minimize slow crack growth effects.

A1.8.3 Conversely, testing can be conducted in controlled environments and specified testing modes and rates (which are representative of service conditions) to evaluate material performance under designated-use conditions.

A1.9 *Out-of-gage failures*—Fractures that initiate outside the uniformly-stressed gage section of a test specimen may be due to factors such as stress concentrations at geometric transitions, extraneous stresses introduced by gripping and/or misalignment, wall thickness variations, or strength-limiting features in the microstructure of the test specimen. Such non-gage section fractures will normally constitute invalid tests. For gripping systems, grip pressure is a key variable in the initiation of fracture, as described in A1.7.

A2. TEST SPECIMEN GEOMETRY AND PREPARATION

A2.1 The selection and definition of a tubular test specimen geometry depends on the purpose of the tensile testing effort. For example, if the tensile strength of an as-fabricated component with a defined geometry is required, the dimensions of the tensile test specimen may reflect the wall thickness, tube diameter, and length restrictions of the component. If it is desired to evaluate the effects of interactions of various constituent materials for a particular CFCC manufactured via a particular processing route, then the size of the test specimen and resulting gage section will reflect the size and geometry limits of that processing method. In addition, grip devices and load train couplers as discussed in Section 7 will influence the final design of the test specimen geometry.

A2.2 *Test Specimen Geometries*—Tubular test specimens are classified into two groups—straight-sided specimens and contoured gage sections. Examples of straight-sided and contoured gage tube test specimens are shown in Figs. A2.1-A2.4.

A2.2.1 The straight-sided and contour gage specimens shown in Figs. A2.1-A2.3 can be used in active grips and in adhesive-bonded grips. In contoured gage specimens, the grip sections are built up by adhesive tabs/collars in the grip sections (Fig. A2.2) or formed by integral thick walls in the grip sections of the composite (Fig. A2.3). The test specimen with the tapered shoulders (Fig. A2.4) is designed for passive mechanical grips.

A2.2.2 As a starting point, the wall thickness of the grip section should be at least twice (2×) as thick as the wall thickness of the gage. A key factor in the contoured gage design is the minimizing the stress concentration at the geometric transitions into the gage sections. As a general rule, sharp corners should be avoided and the radius in the transition contour should be 50 mm, large enough to minimize stress concentrations. Often the transition radius is 3× to 10× the wall thickness of the gage section. (For example, a 3 mm gage wall thickness would have a 9 mm or greater transition radius.)

A2.3 *Test Specimen Dimensions*—Although the diameters and wall thickness of CFCC tubes can vary widely depending on application, experience has shown (4, 5, 6, 7, 8, 9) that successful tests are commonly achieved within these ranges of relative dimensions, as follows.

$$2 < L_g / d_o < 3 \tag{A2.1}$$

$$15 < L_g / t < 30 \tag{A2.2}$$

where L_g is the gage length (grip to grip length), d_o is the outer diameter in the gage section, and t is the wall thickness in the gage section of the tube. Deviations outside the recommended ranges may be necessary depending upon the particular CFCC being evaluated.

A2.3.1 The example geometries are specific to certain CFCC composites and test requirements. Any CFCC tube

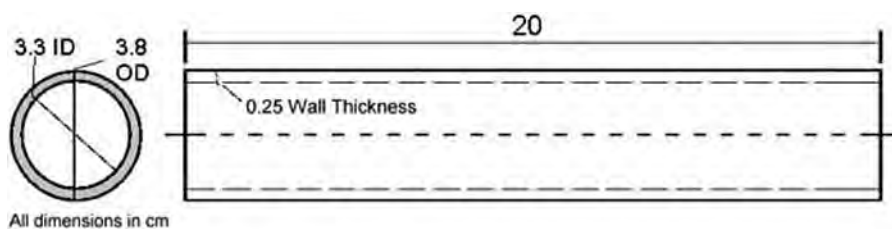

FIG. A2.1 Example of a Straight-Sided Tube Test Specimen (4)

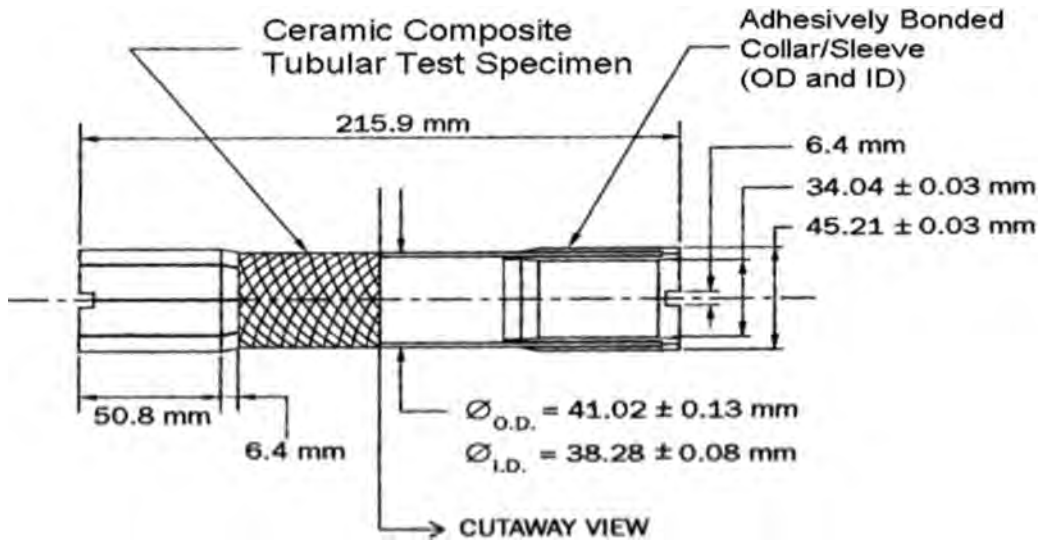

FIG. A2.2 Example of a Contoured Gage Tube Test Specimen with Bonded Grip Collars (9)

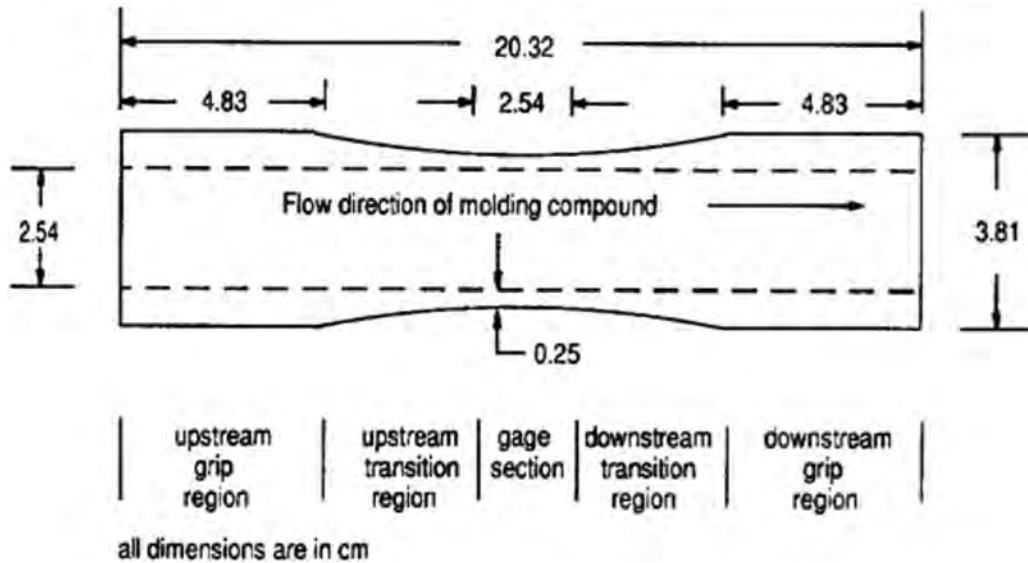

FIG. A2.3 Example of a Contoured Gage Tube Test Specimen with Integrated Thick Wall Grip Section (8)

geometry is acceptable if it meets the dimensional, gripping, fracture location, and bending requirements of this test method.

A2.4 Stress analyses of untried test specimen geometries should be conducted to ensure that stress concentrations that can lead to undesired fractures outside the gage sections do not exist. It should be noted that contoured specimens by their nature contain inherent stress concentrations due to geometric transitions. Stress analyses can indicate the magnitude of such stress concentrations while revealing the success of producing a uniform tensile stress state in the gage section of the test specimen.

A2.5 In certain instances, low interfacial shear strength relative to the tensile strength in the fiber direction will cause splitting of the tubular test specimen initiating at the transition region between the gage section and the gripped section of the test specimen with the split propagating along the fiber

direction leading to fracture of the test specimen. In these cases, straight-sided (that is, non-contoured) specimens as shown in Fig. A2.1, may be required for producing tensile failure in the gage section of the tube. In other instances, a particular fiber weave or processing route will preclude fabrication of test specimens with integral contoured gage sections, thus requiring the use of straight-sided specimens.

A2.6 Collars/Sleeves—Geometry, Material and Bonding—Collars/sleeves may be attached to the grip section of the test specimen (OD and/or ID) to provide a suitable gripping surface and to build up the strength of the grip sections. They produce a uniformly circular shape that fits snugly into the gripping/bonding device. The collars often have a tapered (<math><45^\circ</math>) leading edge which transition smoothly into the gage section. Collars have been made with aluminum and with epoxy/graphite and are formed/machined to fit snugly onto/into the

Tubular Test Specimen with Tapered Shoulders

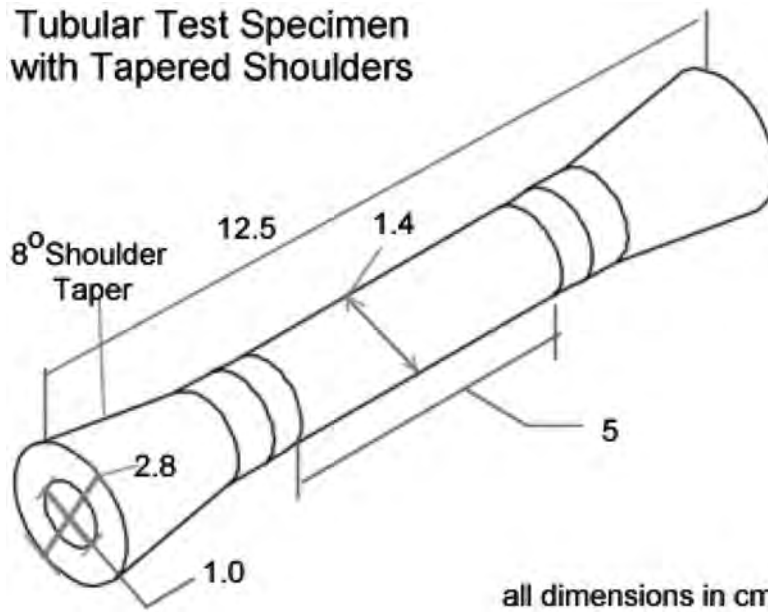

FIG. A2.4 Example of a Contoured Gage Tube Test Specimen with Tapered Shoulders (7)

grip section of the test specimen. The collars are adhesively bonded (with tough, high strength epoxy) on/in the grip section. Complete and uniform bonding is necessary across the mating surfaces between the collar and the test specimen. After bonding, the diameter of collared gage section may be turned/machined to fit into the grips.

A2.7 Test Specimen Preparation—Machining/grinding of the tubular test specimens may be necessary of two purposes: (1) to develop a controlled OD or ID in the gage and/or (2) to produce a uniform OD/ID in the grip section for fitting into the grip fixture. However, there are currently no standardized surface preparation/machining methods for ceramic composite tensile tests. Depending upon the intended application of the tensile strength data, use one of the four following test specimen preparation procedures.

A2.7.1 As-Fabricated—The tubular tensile test specimen should simulate the surface/edge conditions and processing route of an application where no machining is used; for example, as-cast, sintered, or injection molded part. No additional machining specifications are relevant. As-processed test specimens might possess rough surface textures and nonuniform wall thicknesses and as such may cause excessive misalignment or be prone to nongage section fractures, or both.

A2.7.2 Application-Matched Machining—The tubular tensile test specimen should have the same surface/edge preparation as that given to the component. Unless the process is proprietary, the report should be specific about the stages of

material removal, wheel grits, wheel bonding, amount of material removed per pass, and type of coolant used.

A2.7.3 Customary Practices—In instances where a customary machining procedure has been developed and defined that is completely satisfactory for a class of materials (that is, it induces no unwanted surface/subsurface damage or residual stresses), this procedure should be used.

A2.7.4 Standard Procedure—In instances where as-fabricated, application-matched, and customary practices are not appropriate, the baseline cutting and grinding rules (described below) should apply. Studies to evaluate the machinability of CFCCs have not been completed. Therefore, these baseline rules can be viewed as starting-point guidelines; more detailed and stringent procedures may be necessary for specific CFCC systems.

A2.7.5 Stock removal rate should be on the order of 0.03 mm per pass using diamond tools that have between 320 and 600 grit. Remove equal stock from around the circumference, where applicable.

A2.7.6 All grinding or cutting should be done with ample supply of appropriate filtered coolant to keep the workpiece and grinding wheel cool, constantly flooded, and particles flushed. Grinding can be done in at least two stages, ranging from coarse to fine rate of material removal. All cutting can be done in one stage appropriate for the depth of cut. The test specimen should be fully dried after wet cutting.

A3. GRIP FIXTURES AND LOAD TRAIN COUPLERS

A3.1 *Active grip fixtures*—Active grip interfaces use the direct application of a gripping force normal to the grip section of the tube test specimen. These active grips commonly use split circular collets that encircle the outer circumference of the tube. The collet sections are compressed onto the surface of the tube through mechanical, hydraulic or pneumatic action, either through direct lateral compression or wedging. This gripping action transmits the uniaxial force applied by the test machine by friction between the collet faces and the grip section of the test specimen (either with or without collars). Thus, two important aspects of active grip interfaces are uniform contact and an effective coefficient of friction over the grip/specimen interface.

A3.1.1 Examples of collet type active grips are shown in Figs. A3.1 and A3.2.

A3.1.2 In Fig. A3.1, the two piece collet is compressed around the tube test specimen by the downward action of the seating core threaded into the grip sleeve. In Fig. A3.2 the pulling action of the piston compresses the flexible segments of the collet around the tube specimen. This design also uses an end plug in the interior of the tube to prevent crushing. The grip base also has x-y alignment adjustment screws. Generally, close tolerances are required for the diameter of the grip section of the specimen, because of low diametral tolerance in the collet. Actual tolerances will depend on the exact configuration and acceptance dimensions of the collet. A uniform diameter of the tube specimen may be produced by direct machining/turning of the grip section. An alternative to direct machining of the CMC grip section is the use of an epoxy

coating (2-5 mm) on the OD of the grip section, which is then machined/ground to a uniform diameter (4, 5).

A3.1.3 The length of the grip section has to be long enough to develop sufficient friction force to transmit the tensile forces to the test specimen. Higher fracture forces (seen with very strong, straight wall specimens and with thick wall specimens) will require greater grip lengths. As a general rule, grip lengths are $> 1.5\times$ the outer diameter of the specimen. If the test specimens are pulling out of the grips, longer grip lengths (or higher gripping pressures) may be needed.

A3.1.4 The length of the collet grip surfaces should be equal to or greater than the respective length of the grip sections of the test specimen. Sufficient lateral pressure must be applied to prevent slippage between the collet grip face and the tubular specimen. There must also be sufficient friction between the grip surface and the test specimen. Grip surfaces that are scored or serrated with a pattern similar to that of a single-cut file have been found satisfactory. A fine serration appears to be the most satisfactory. The serrations should be kept clean and well defined but not overly sharp. The grip surface of the test specimen may also be roughened up if it has a smooth finish.

A3.2 *End Plugs*—To prevent lateral crushing of the tubular test specimen by the collet and subsequent collapse of the tube wall, an internal plug can be inserted into the interior of the grip section of the test specimen. The plugs should have the same length as the grip section itself. Plugs are commonly steel or aluminum and machined to fit snugly into the ID of the test specimen. The interior surface of the grip section of the tube

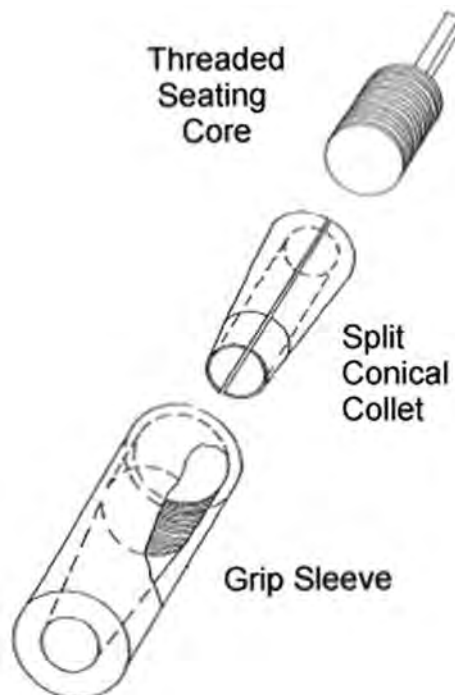

FIG. A3.1 Schematic of Collet Grips for a Composite Tube (25 cm long, 2.75 cm OD, 2mm wall) (3)

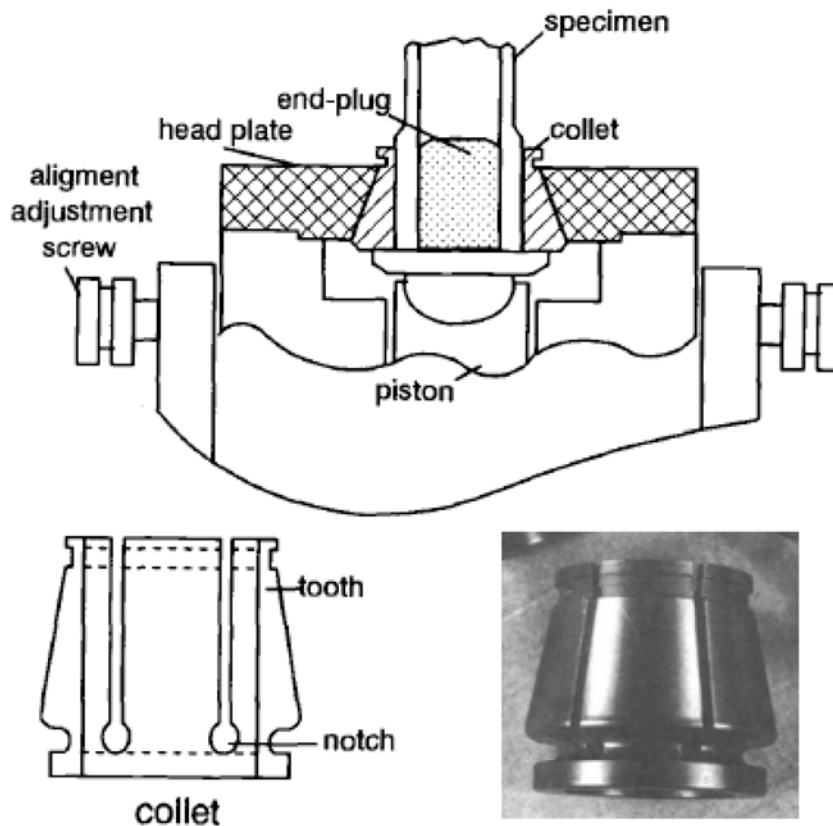

FIG. A3.2 Schematic of Collet Grips for a Composite Tube (20 cm long, 3.8 cm OD, 2.5 mm wall) (4)

specimen may be machined smooth and circular to accept the plug with a tight fit. The plugs are bonded in place with a tough, high strength epoxy (4, 5).

A3.3 *Passive grip fixtures*—Passive grip interfaces transmit the force applied by the test machine to the tubular test specimen through an adhesive bond to the grips or by direct mechanical links. Generally, these mechanical links transmit the test forces to the test specimen via geometric features (shoulders, tapers, etc) on the test specimens.

A3.4 *Adhesive Bonding*—Two examples of adhesive bonding grips are shown in Figs. A3.3 and A3.4.

A3.4.1 An adhesive with high shear strength is commonly used to bond the test specimen into the fixture. A commonly used adhesive is a two-part room-temperature curing, tough, high strength [20–35 MPa (3–5 ksi)] epoxy.

A3.4.2 The specimen tube must fit snugly in the bonding cavity with a thin (~0.1–0.2 mm) space for the adhesive, providing uniform bonding contact between the gripped section of the test specimen and the grip cavity. Bonding is commonly done on the OD for the grip configuration shown in Fig. A3.3. Grips with center cores, as shown in Fig. A3.4, can have bonding on both the OD and the ID of the test specimen.

A3.4.3 Insufficient bonding surface in the grips will produce bond failure before specimen failure. As a rule of thumb the

bond shear forces which develop from the maximum tensile force should produce shear stresses <50% of the nominal shear strength of the adhesive. The required length of the bonding surface length for tube can be estimated with the following equation.

$$\text{Bonding Length} = L_{bond} = K \times (S_u/S_{adh}) \times (d_o^2 - d_i^2)/(4D_{bond}) \quad (A3.1)$$

where:

- L_{bond} = required length/depth of the bonding zone,
- K = selected safety factor (2 for 50% reduction),
- S_u = expected tensile strength of the composite,
- S_{adh} = shear strength of the adhesive,
- d_o = outer diameter of the tube specimen
- d_i = inner diameter of the tube specimen, and
- D_{bond} = effective diameter of the bonding zone [d_o for bonding on the OD circumference; $(d_o + d_i)$ for bonding on the outer and inner circumference].

See Fig. A3.5.

A3.4.4 In bonded grip systems, one of the concerns is the removal of the test specimen from the grips after testing. The adhesive must be removed by either chemical or thermal action, depending on the nature of the adhesive. A two part grip (as shown in Fig. A3.4) is easier to disassemble and clean for reuse.

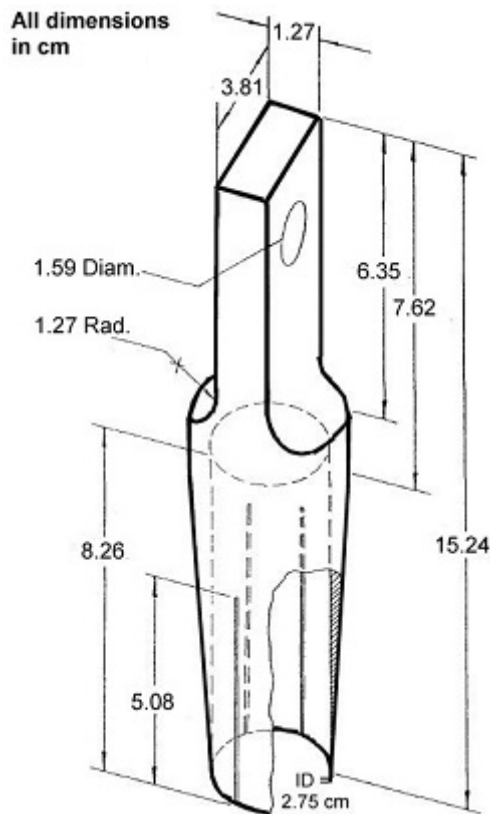

FIG. A3.3 Adhesive Bonding Grip Fixture for a Straight-Sided Composite Tube (25 cm long, 2.75 cm OD, 2 mm wall) (3)

A3.5 *Passive Mechanical Bonding*—In passive mechanical bonding there is no active gripping of the test piece and gripping does not depend on frictional forces. Two examples of passive mechanical bonding grips are shown in Figs. A3.6 and A3.7.

A3.5.1 Fig. A3.6 shows a passive mechanical grip in which a split collet with a tapered center core supports a tensile specimen with tapered shoulders. The critical geometry factors in this fixture are a good fit and uniform contact between the tapered shoulders of the specimen and the tapered core of the split collet (7).

A3.5.2 Fig. A3.7 shows a pin-loaded fixture in which steel pins are inserted through the composite tube walls and through the end plugs which are epoxied into the two ends of the composite. The pins are primarily for force transmission purposes with a secondary role of alignment in the load train. In this study (5), the ceramic matrix composite was ~15% porous. The epoxy penetrated into the composite and strengthened the end sections, producing tensile failure in the as-fabricated gage section.

A3.5.3 For high tensile strength composites, pin loading in the grip section is not recommended. Relatively low interfacial shear strengths in CFCCs (particularly for 1-D reinforced materials loaded along the fiber direction) may promote

non-gage section fractures at stress concentrations and at localized loading points, such as holes.

A3.6 *Load Train Couplers*—The load train couplers in conjunction with the type of gripping device play major roles in the alignment of the load train and control of any bending imposed in the test specimen. Load train couplers can be generally classified as fixed and non-fixed as discussed in the following sections.

A3.6.1 Note that use of well-aligned fixed or self-aligning non-fixed couplers does not automatically guarantee low bending in the gage section of the tubular tensile specimen. The alignment and operation of the grips on the test specimen, as well as asymmetries in the dimensions of the test specimen, can induce bending stresses in the gage section of the test specimen.

A3.6.2 *Fixed load train couplers*—Fixed couplers (8, 9) with concentricity and angularity adjustments may require either a one-time, pre-test alignment adjustment of the load train which remains constant for all subsequent tests or an in-situ, pre-test alignment of the load train that is conducted separately for each test specimen and each test. Regardless of which method is used, alignment verification must be performed as discussed in 7.2.4.

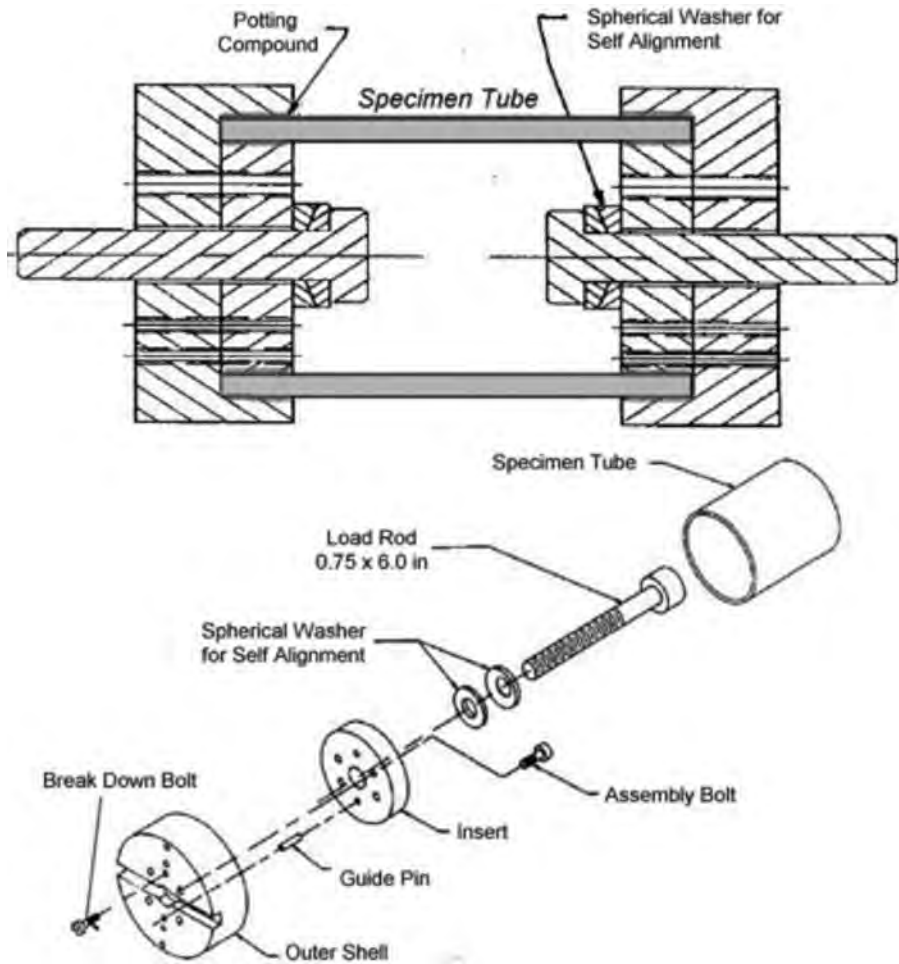

FIG. A3.4 Schematic of a Adhesive Bonding Grip Fixture for a Straight-Sided Composite Tube (14 cm long, 10 cm OD, 2 mm wall) (6)

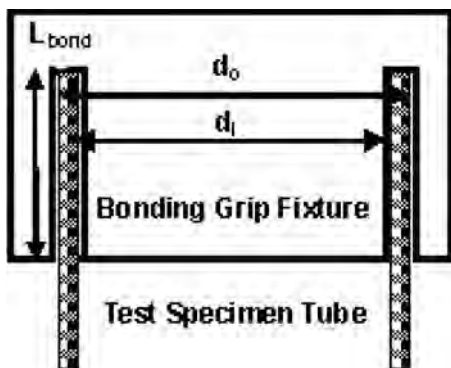

FIG. A3.5 Schematic of Bonding Grip Fixture

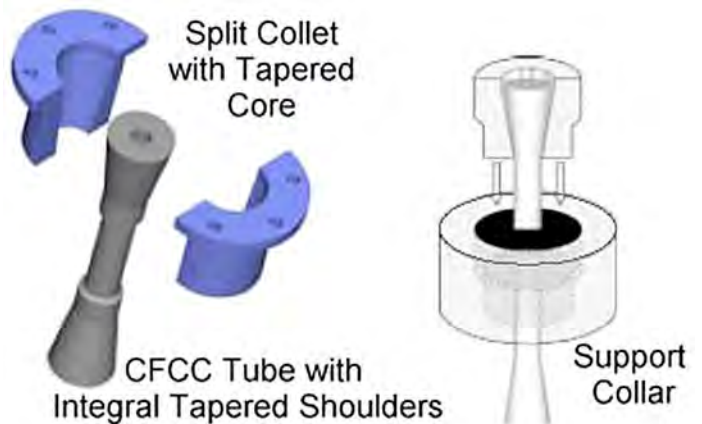

FIG. A3.6 Passive Mechanical Grip Fixture for Specimens with Tapered Shoulders (12.5 cm long, 1.4 cm OD, 2.1 mm wall, 8° shoulder taper) (7)

A3.6.3 Fixed load train couplers are preferred in monotonic testing CFCCs because of the “graceful” fracture process in these materials. During this “graceful” fracture process, the fixed coupler tends to hold the test specimen in an aligned position, and thus, provides a continuous uniform stress across the remaining ligament of the gage section.

A3.6.4 *Non-fixed load train couplers*—Non-fixed couplers may incorporate devices that permit self-alignment of the load train during the movement of the crosshead or actuator. These devices generally rely upon freely moving linkages to elimi-

nate applied moments as the load train is stressed. Pin universal joints, knife edges, hydraulic couplers or air bearings are examples (10, 11, 16) of such devices. An example of a pin universal joint coupler (3) is shown in Fig. A3.8. Although non-fixed load train couplers are intended to be self-aligning and thus eliminate the need to evaluate the bending in the

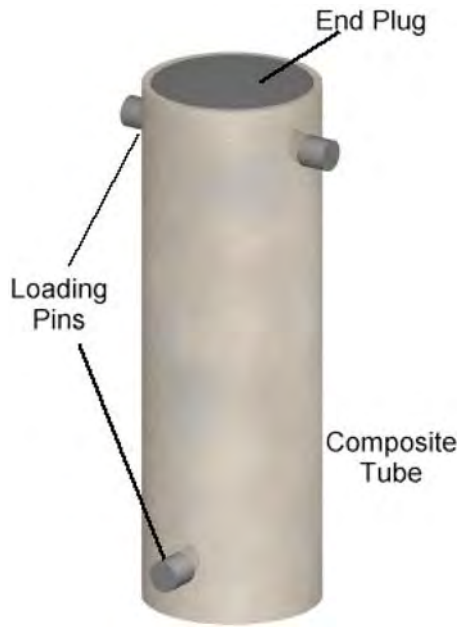

FIG. A3.7 Passive Pin and Epoxy-End Plug Grip Fixture for a Straight-sided Composite Tube (18 cm long, 6 cm OD, 5 mm wall) (5)

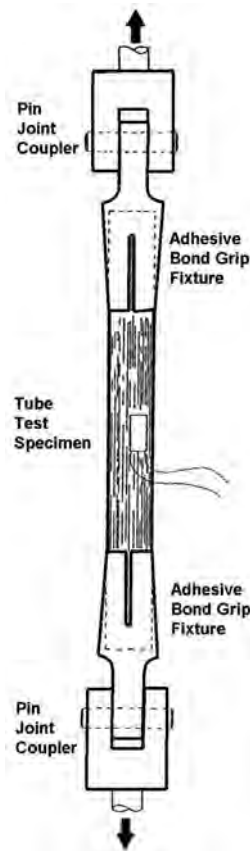

FIG. A3.8 Pin Universal Joint Load Couplers (3)

specimen for each test, the operation of the couplers and load train alignment must be verified as discussed in 7.2.4.

A3.6.5 Non fixed load train couplers are useful in rapid test rate or constant load testing of CFCCs where the “graceful”

fracture process is not as apparent. If the material exhibits “graceful” fracture the self aligning feature of the non-fixed coupler will allow rotation of the gripped section of the test

specimen thus promoting a non-uniform stress in the remaining ligament of the gage section.

A4. ALLOWABLE BENDING AND LOAD TRAIN ALIGNMENT

A4.1 Analytical and empirical studies on monolithic advanced ceramics (14) have concluded that for negligible effects on the estimates of the strength distribution parameters (for example, Weibull modulus, \hat{m} , and characteristic strength, $\hat{\sigma}_0$), allowable percent bending as defined in Practice E1012 should not exceed five percent (5%).

A4.1.1 Similar studies of the effect of bending on the tensile strength distributions of CFCCs do not exist. Until such information is forthcoming for CFCCs, this test method adopts the recommendations used in tensile testing of monolithic ceramics (ASTM C1273). Therefore, the recommended maximum allowable percent bending at the onset of the cumulative fracture process (for example, matrix cracking stress) for test specimens tested under this test method is five (5%).

A4.1.1.1 It should be noted that unless all test specimens are properly strain gaged and percent bending monitored until the onset of the cumulative fracture process, there will be no record of percent bending at the onset of fracture for each test specimen. Therefore, the testing system shall be verified using the procedure detailed in the Annex such that percent bending does not exceed five at a mean strain equal to either one half the anticipated strain at the onset of the cumulative fracture process (for example, matrix cracking stress) or a strain of 0.0005 (that is, 500 microstrain) whichever is greater.

A4.1.2 Regardless of which type of coupler is used, alignment of the testing system shall be verified at a minimum at the beginning and end of a test series unless the conditions for verifying alignment as detailed in A4.2 are otherwise met.

NOTE A4.1—A test series is interpreted to mean a discrete group of tests on individual test specimens conducted within a discrete period of time on a particular material configuration, test specimen geometry, test conditions, or other uniquely definable qualifier (for example, a test series composed of material A comprising ten test specimens of geometry B tested at a fixed rate in strain control to final fracture in ambient air). An additional verification of alignment is recommended, although not required, at the middle of an extended test series.

A4.1.3 The alignment verification procedures are detailed in A4.2 and either a dummy or an actual test specimen must be used. Allowable bending requirements are discussed in 7.2.4. Tubular tensile specimens used for alignment verification should be equipped with a recommended eight separate longitudinal strain gages to determine bending contributions from both eccentric and angular misalignment of the grip heads. Ideally the verification specimen should be of identical material to that being tested. However, in the case of CFCCs, the type of reinforcement or degree of residual porosity may complicate the consistent and accurate measurement of strain. Therefore, an alternate material (isotropic, homogeneous, continuous) with elastic modulus, elastic strain capability, and

hardness similar to the test material is recommended. In addition, dummy tubular test specimens used for alignment verification should have the same geometry and dimensions of the actual tubular test specimens as well as similar mechanical properties as the test material to ensure similar axial and bending stiffness characteristics as the actual test specimen and material.

A4.2 Verification of Load Train Alignment:

A4.2.1 Purpose of Verification—The purpose of this verification procedure is to demonstrate that the grip system and load train couplers can be used by the test operator in such a way as to consistently meet the limit on percent bending as specified in 7.2.4. Thus, this verification procedure should involve no more care in setup than will be used in the routine testing of the actual tensile specimen. The bending under tensile force should be measured using verification (or actual) specimens of exactly the same design as that to be used for the tensile tests. For the verification purposes, strain gages should be applied as shown in Fig. A4.1. Verification measurements should be conducted at the beginning and end of a series of tests with a measurement at the midpoint of the series recommended, whenever the grip interfaces and load train couplers are installed on a different test machine, whenever a different operator is conducting a series of tests, or when damage or misalignment is suspected.

A4.2.2 Verification Specimen—The specimen used for verification must be machined very carefully with attention to all tolerances and concentricity requirements. Ideally the verification specimen should be of identical material to that being tested. However, in the case of CFCCs the type of reinforcement or degree of residual porosity may complicate the consistent and accurate measurement of strain. Therefore, it is recommended that an alternate material (isotropic, homogeneous, and continuous) should be used with elastic modulus, elastic strain capability, and hardness similar to the test material. The verification specimen should be carefully inspected with an optical comparator before strain gages are attached to ensure that these requirements are met. After the strain gages are applied it will no longer be possible to meaningfully inspect the specimen, so care should be exercised in handling and using it.

A4.2.3 For simplicity, a minimum of eight foil resistance strain gages should be mounted on the verification specimen as shown in Fig. A4.1. Note that the strain gage planes should be separated by $\frac{3}{4} L_o$ where L_o is the length of the reduced or designated gage section. In addition, care must be taken to select the strain gage planes to be symmetrical about the

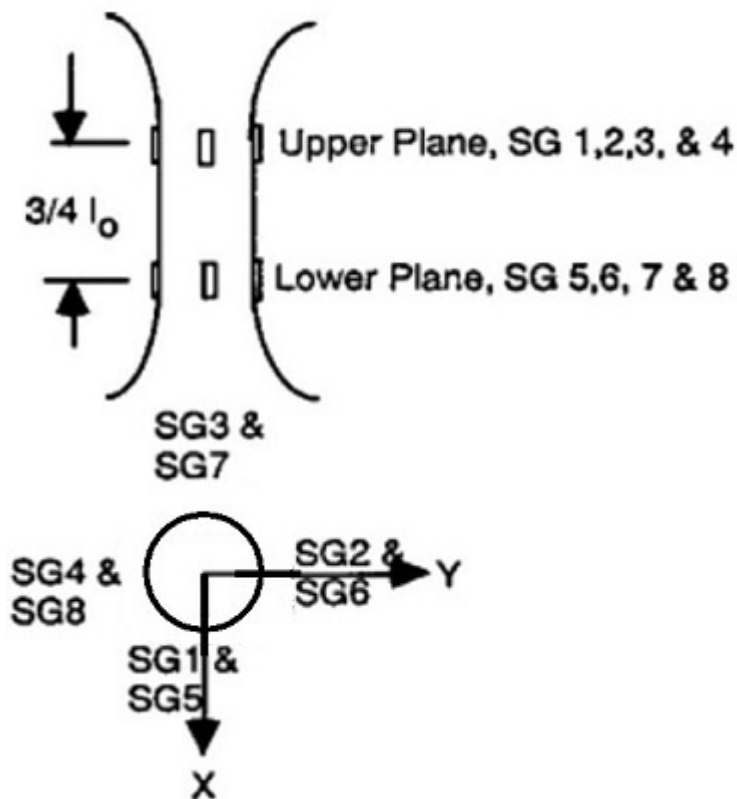

FIG. A4.1 Illustration of Strain Gage Placement on Gage Section Planes and Strain Gage Numbering

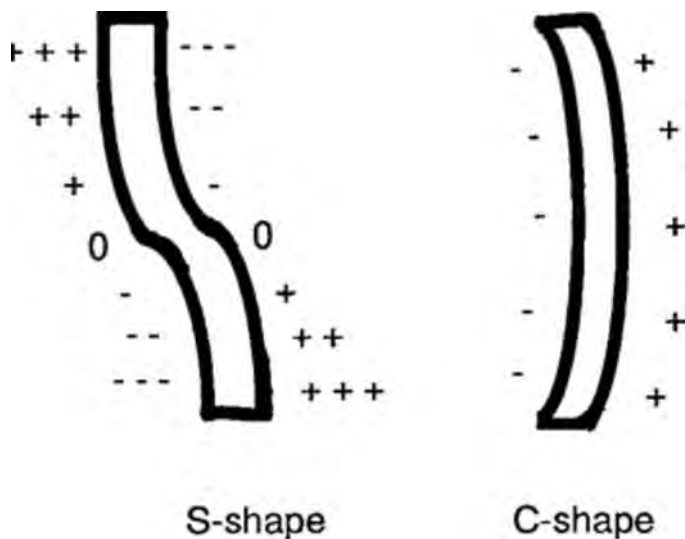

FIG. A4.2 S-Shape and C-Shape Bending of Tensile Specimen

longitudinal midpoint of the gage section to avoid placing the strain gages closer than one strain gage length from geometrical features, such as the transition radius from the gage section.

A4.2.4 Strain gages on dummy specimens composed of isotropic homogeneous materials should be as narrow as possible to minimize strain averaging. Strain gages having active widths of 0.25 to 0.5 mm and active lengths of 1.0 to 2.5 mm are commercially available and are suitable for this purpose. Otherwise, strain gages on test specimens composed

of CFCC materials should be of the size recommended in 7.3.2. Four strain gages, equally spaced (90° apart) around the circumference of the gage section (that is, one strain gage on each face), should be mounted at each of two planes at either end of the gage section. These planes should be symmetrically located about the longitudinal midpoint of the gage section. Note that care should be taken to avoid placing the strain gages too near geometric transitions in the gage section, which can cause strain concentrations and inaccurate measures of the strain in the uniform gage section.

A4.2.5 *Verification Procedure*—Procedures for verifying alignment are described in detail in Practice E1012. However, salient points for round cross sections are described here for emphasis.

A4.2.6 Connect the lead wires of the strain gages to the conditioning equipment and allow the strain gages to equilibrate under power for at least 30 min prior to conducting the verification tests. This will minimize drift during actual conduct of the verifications.

A4.2.7 Mount the top of the verification specimen in the grip interface.

A4.2.8 Zero the strain gages before mounting the bottom of the verification specimen in the grip interface. This will allow any bending due to the grips to be recorded.

A4.2.9 Mount the bottom of the verification specimen in the grip interface.

A4.2.10 Apply a sufficient force to the verification specimen to achieve a mean strain equal to either one half the anticipated strain at the onset of the cumulative fracture process (for example, matrix cracking stress) in the test material or a strain of 0.0005 (that is, 500 microstrain) whichever is greater. Note that it is desirable to record the strain (and hence percent bending) as functions of the applied force to monitor any self alignment of the load train.

A4.2.11 Calculate percent bending as follows referring to Fig. A4.1 for the strain gage numbers. Percent bending at the upper plane of the gage section is calculated as follows:

$$PB_{upper} = \frac{\varepsilon_b}{\varepsilon_o} 100 \quad (A4.1)$$

Where

$$\varepsilon_b = \left[\left(\frac{\varepsilon_1 - \varepsilon_3}{2} \right)^2 + \left(\frac{\varepsilon_2 - \varepsilon_4}{2} \right)^2 \right]^{1/2} \quad (A4.2)$$

$$\varepsilon_o = \frac{\varepsilon_1 + \varepsilon_2 + \varepsilon_3 + \varepsilon_4}{4} \quad (A4.3)$$

where ε_1 , ε_2 , ε_3 and ε_4 are strain readings for strain gages located at the upper plane of the gage section. Note that strain gage readings are in units of strain and compressive strains are negative.

A4.2.12 The direction of the maximum bending strain on the upper plane is determined as follows:

$$\theta_{upper} = \arctan \left[\frac{\varepsilon_{(next\ greatest\ of\ 1,2,3,4)} - \varepsilon_o}{\varepsilon_{(greatest\ of\ 1,2,3,4)} - \varepsilon_o} \right] \quad (A4.4)$$

where θ_{upper} is measured from the strain gage with the greatest reading in the direction of the strain gage with the second greatest reading where counter clockwise is positive.

A4.2.13 Percent bending at the lower plane of the gage section is calculated as follows:

$$PB_{lower} = \frac{\varepsilon_b}{\varepsilon_o} 100 \quad (A4.5)$$

Where

$$\varepsilon_b = \left[\left(\frac{\varepsilon_5 - \varepsilon_7}{2} \right)^2 + \left(\frac{\varepsilon_6 - \varepsilon_8}{2} \right)^2 \right]^{1/2} \quad (A4.6)$$

$$\varepsilon_o = \frac{\varepsilon_5 + \varepsilon_6 + \varepsilon_7 + \varepsilon_8}{4} \quad (A4.7)$$

where ε_5 , ε_6 , ε_7 and ε_8 are strain readings for strain gages located at the lower plane of the gage section. Note that strain gage readings are in units of strain and compressive strains are negative.

A4.2.14 The direction of the maximum bending strain on the lower plane is determined as follows:

$$\theta_{lower} = \arctan \left[\frac{\varepsilon_{(next\ greatest\ of\ 5,6,7,8)} - \varepsilon_o}{\varepsilon_{(greatest\ of\ 5,6,7,8)} - \varepsilon_o} \right] \quad (A4.8)$$

where θ_{lower} is measured from the strain gage with the greatest reading in the direction of the strain gage with the second greatest reading where counter clockwise is positive.

A4.2.15 Note that for the following comparisons, θ_{upper} and θ_{lower} may be adjusted to reference the same point on the circumference. Since strain gages 1 and 5 fall on the same longitudinal line around the circumference, for consistency these may be used as reference points for θ_{upper} and θ_{lower} , respectively. For example, on the upper plane, if strain gage 2 is the greatest measured strain with strain gage 3 being the next greatest measured strain then the direction of the maximum bending strain with reference to strain gage 1 is $\theta_{upper} + 90^\circ$ in counterclockwise direction (that is, from strain gage 1 to 2). For uniform bending across the gage section with the specimen assuming a C-shape, $PB_{upper} \approx PB_{lower}$ and $|\theta_{upper} - \theta_{lower}| \approx 0^\circ$. C-shape bending reflects angular misalignment of the grips. For non-uniform bending across the gage section with the specimen assuming an S-shape, PB_{upper} may or may not be equal to PB_{lower} and $|\theta_{upper} - \theta_{lower}| \approx 180^\circ$. S-shape bending reflects eccentric misalignment of the grip centerlines. These general tendencies are shown in Fig. A4.2. Combinations of C and S shapes may exist where $>$ and $|\theta_{upper} - \theta_{lower}|$ is some angle between 0 and 180° . In these cases the S-shape should first be eliminated by adjusting the concentricity of the grips such that the longitudinally aligned strain gages indicate approximately the same values (for example, $\varepsilon_1 \approx \varepsilon_5$, $\varepsilon_2 \approx \varepsilon_6$, etc.). More detailed discussions regarding bending and alignment are contained in (13).

A4.2.16 The effect of the specimen warpage can be checked by rotating the specimen 180° about its longitudinal axis and performing the bending checks again. If similar results are obtained at each rotation then the degree of alignment can be considered representative of the load train and not indicative of the specimen. If load train alignment is within the specifications of 7.2.4, the maximum percent bending should be recorded and the tensile tests may be conducted. If the load train alignment is outside the specifications of 7.2.4, then the load train must be aligned or adjusted according to the specific procedures unique to the individual testing setup. This verification procedure must then be repeated to confirm the achieved alignment.

A5. TEST MODES AND RATES

Test modes and rates can have distinct and strong influences on fracture behavior of advanced ceramics even at ambient temperatures depending on test environment or condition of the test specimen. Test modes may involve strain, displacement, or force control. Recommended rates of testing are intended to be sufficiently rapid to obtain the maximum possible tensile strength at fracture of the material.

A5.2 For monolithic advanced ceramics exhibiting linear elastic behavior, fracture is attributed to a weakest-link fracture mechanism generally attributed to stress-controlled fracture from Griffith-like flaws. Therefore, a force-controlled test, with force generally related directly to tensile stress, is the preferred test mode.

A5.3 However, in CFCCs the non-linear stress-strain behavior characteristic of the “graceful” fracture process of these materials indicates a cumulative damage process that is strain-dependent. Generally, displacement or strain-controlled tests are employed in such cumulative damage processes to prevent a “run away” condition (that is, rapid uncontrolled deformation and fracture) which can occur with force- or stress-controlled tests. Thus, to elucidate the potential “toughening” mechanisms under controlled fracture of the CFCC, displacement or strain control is preferred. However, for sufficiently rapid test rates, differences in the fracture process may not be noticeable and any of these test modes may be appropriate.

A5.4 *Strain Rate*—Strain is the independent variable in non-linear analyses such as yielding. As such, strain rate is a method of controlling tests of deformation processes to avoid “run away” conditions. For the linear elastic region of CFCCs, strain rate can be related to stress rate such that:

$$\dot{\varepsilon} = \frac{d\varepsilon}{dt} = \frac{\dot{\sigma}}{E} \quad (\text{A5.1})$$

where:

- $\dot{\varepsilon}$ = the strain rate in the test specimen gage section in units of s^{-1} ,
- ε = the strain in the tubular test specimen gage section,
- t = time in units of s,
- $\dot{\sigma}$ = the nominal stress rate in the test specimen gage section in units of MPa/s, and
- E = the elastic modulus of the CFCC in units of MPa.

A5.4.1 Strain-controlled tests can be accomplished using an extensometer contacting the gage section of the test specimen as the primary control transducer. Strain rates on the order of 50×10^6 to $500 \times 10^6 \text{ s}^{-1}$ are recommended to minimize environmental effects when testing in ambient air. Alternately, strain rates shall be selected to produce final fracture in 5 to 60 s to minimize environmental effects when testing in ambient air.

A5.5 *Displacement Rate*—The size differences of each test specimen geometry require a different loading rate for any given stress rate. Note that as the test specimen begins to

fracture, the strain rate in the gage section of the test specimen will change even though the rate of motion of the cross-head remains constant. For this reason displacement rate controlled tests can give only an approximate value of the imposed strain rate. Displacement mode is defined as the control of, or free-running displacement of, the test machine cross-head. Thus, the displacement rate can be calculated as follows. Using the recommended (or desired) strain rate as detailed in A5.4, calculate the displacement rate for the linear elastic region of CFCCs only as:

$$\dot{\delta} = \frac{d\delta}{dt} = \left(\frac{1}{k_m} + \frac{1}{k_s} \right) \dot{\varepsilon} EA \approx \left(\frac{1}{k_m} + \frac{1}{k_s} \right) \dot{\sigma} A \quad (\text{A5.2})$$

where:

- $\dot{\delta}$ = the displacement rate of the crosshead in units of mm/s,
- δ = the crosshead displacement in units of mm,
- k_m = the stiffness of the test machine and load train (including the test specimen ends and the grip interfaces) in units of N/mm,
- k_s = the stiffness of the uniform gage section of the test specimen in units of N/mm,
- E = the elastic modulus of the material in units of MPa, and
- A = the cross sectional area of the gage section of the test specimen.

$$A = \frac{\pi(d_o^2 - d_i^2)}{4} = \pi t(d_o - t) \quad (\text{A5.3})$$

A5.5.1 The cross-sectional area, A , is calculated as for tubular cross sections where d_o is the outer diameter of the gage section in units of mm, d_i is the inner diameter of the gage section in units of mm such $d_i = d_o - 2t$, and t is the wall thick of gage section in mm. Note that k_s can be calculated as $k_s = AE/L$ where L is the gripped length of the test specimen. The stiffness k_m can be determined as per Test Method C1557 by measuring the load-displacement curves for various specimen lengths. The plot of k_m (slope of load-displacement curve) versus specimen length is then extrapolated to zero to find the actual machine stiffness. Alternatively, k_m can be estimated using the manufacturer’s value for frame stiffness as a starting point and decreasing this value as necessary to account for various links in the load train.

A5.6 *Force Rate*—For materials that do not experience gross changes in cross sectional area of the gage section, force rate can be directly related to stress rate and hence to the recommended (or desired) strain rate. Note that as the test specimen begins to fracture, the strain rate in the gage section of the test specimen will change even though the rate of force application remains constant. Stress rates >35 to 50 MPa/s have been used with success to minimize the influence of environmental effects and thus obtain the greatest value of ultimate tensile strength. Alternately, stress or force rates should be selected to produce final fracture in 5 to 50 s to minimize environmental effects when testing in ambient air. For the linear elastic region of CFCCs, force rate is calculated as:

$$\dot{P} = \frac{dP}{dt} = \sigma A \approx \epsilon E \quad (\text{A5.4})$$

where:

\dot{P} = the required force rate in units on N/s, and

P = the applied force in units of N.

A5.7 Ramp Segments—Normally, tests are conducted in a single ramp function at a single test rate from zero force to the

maximum force at fracture. However, in some instances multiple ramp segments might be employed. In these cases a slow test rate is used to ramp from zero force to an intermediate force to allow time for removing “slack” from the test system. The final ramp segment of the test is conducted from the intermediate force to the maximum force at fracture at the required (desired) test rate. The type and time duration of the ramp should be reported.

REFERENCES

- (1) “Ceramic Matrix Composites – Fiber Reinforced Ceramics and Their Applications,” Edited by W. Krenkel, Wiley-VCH Publishers, 2008.
- (2) “Handbook of Ceramic Composites,” Edited by N. P. Bansal, Kluwer Academic Publishers, 2005.
- (3) R. B. Francini, “Characterization of Thin-Wall Graphite/Metal Pultruded Tubing,” *Testing Technology of Metal Matrix Composites*, ASTM STP 964, P.R. DiGiovanni and N.R. Adsit, eds, ASTM International, 1988, pp. 396–408.
- (4) K. Liao, E. R. George, and K. L. Reifsnider, “Characterization of Ceramic Matrix Composite Tubes Under Uniaxial/Biaxial Monotonic and Cyclic Loading,” *Multiaxial Fatigue and Deformation Testing Techniques*, ASTM STP 1280, S. Kalluri and P. J. Bonacuse, Eds., American Society for Testing and Materials, 1997, pp. 224–240.
- (5) R. H. Carter, “Characterizing the Mechanical Properties of Composite Materials Using Tubular Samples,” PhD Thesis, Virginia Polytechnic Institute, Blacksburg, VA, 2001.
- (6) ASTM D5450 Standard Test Method for Transverse Tensile Properties of Hoop Wound Polymer Matrix Composite Cylinders
- (7) W. E. Windes, P. A. Lessing, Y. Katoh, L. L. Snead, E. Lara-Curzio, J. Klett, C. Henager, Jr., R. J. Shinavski, “Structural Ceramic Composites for Nuclear Applications,” Idaho National Laboratory Report, INL/EXT-05-00652, August 2005.
- (8) K. Liao, T. J. Duniyak, W. W. Stinchcomb, and K. L. Reifsnider, “Monitoring Fatigue Damage Development in ceramic Matrix Composite Tubular Specimens by a Thermoelastic Technique,” *Composite Materials: Fatigue and Fracture*, Fourth Volume, ASTM STP 1156, W.W. Stinchcomb and N.E. Ashbaugh, eds., ASTM International, 1993, pp. 620–636.
- (9) F. Ellyn, and Wolodko, “Testing Facilities for Multiaxial Loading of Tubular Specimens,” *Multiaxial Fatigue and Deformation Testing*, ASTM STP 1280, S. Kalluri and P.J. Bonacuse, eds., ASTM International, 1997, pp. 7–24.
- (10) J. E. Amaral and C. N. Pollock, “Machine Design Requirements for Uniaxial Testing of Ceramics Materials,” *Mechanical Testing of Engineering Ceramics at High Temperatures*, B. F. Dyson, R. D. Lohr, and R. Morrell, eds., 1989, pp. 51–68.
- (11) L. G. Mosiman, T. L. Wallenfelt, and C. G. Larsen, “Tension/Compression Grips for Monolithic Ceramics and Ceramic Matrix Composites,” *Ceramic Engineering and Science Proceedings*, 12(7–8), 1991.
- (12) K. C. Liu, and C. R. Brinkman, “Tensile Cyclic Fatigue of Structural Ceramics,” *Proceedings of the 23rd Automotive Technology Development Contractors’ Coordination Meeting*, P-165, SAE Warrendale, PA, 1986, pp. 279–284.
- (13) L. C. Mejia, “High Temperature Tensile Testing of Advanced Ceramics,” *Ceramic Engineering and Science Proceedings*, 10 (7–8), 1989, pp. 668–681.
- (14) M. G. Jenkins, M. K. Ferber, R. L. Martin, V. T. Jenkins, V. J. Tennery, “Study and Analysis of the Stress State in a Ceramic, Button-Head, Tensile Specimen,” Oak Ridge National Laboratory Technical Memorandum, ORNL/TM 11767, September 1991.
- (15) M. E. Tuttle, and H. F. Brinson, “Resistance-Foil Strain-Gage Technology as Applied to Composite Materials,” *Experimental Mechanics*, Vol 24, No. 1, March 1984; pp. 54–64; errata noted in Vol 26, No. 2, Jan. 1986, pp. 153–154.
- (16) C. G. Larsen, “Ceramics Tensile Grip,” ASTM STP 1080, Editors: J. M. Kennedy, H. H. Moeller, and W. W. Johnson, 1990, pp. 1610–1614.

ASTM International takes no position respecting the validity of any patent rights asserted in connection with any item mentioned in this standard. Users of this standard are expressly advised that determination of the validity of any such patent rights, and the risk of infringement of such rights, are entirely their own responsibility.

This standard is subject to revision at any time by the responsible technical committee and must be reviewed every five years and if not revised, either reapproved or withdrawn. Your comments are invited either for revision of this standard or for additional standards and should be addressed to ASTM International Headquarters. Your comments will receive careful consideration at a meeting of the responsible technical committee, which you may attend. If you feel that your comments have not received a fair hearing you should make your views known to the ASTM Committee on Standards, at the address shown below.

This standard is copyrighted by ASTM International, 100 Barr Harbor Drive, PO Box C700, West Conshohocken, PA 19428-2959, United States. Individual reprints (single or multiple copies) of this standard may be obtained by contacting ASTM at the above address or at 610-832-9585 (phone), 610-832-9555 (fax), or service@astm.org (e-mail); or through the ASTM website (www.astm.org). Permission rights to photocopy the standard may also be secured from the ASTM website (www.astm.org/COPYRIGHT).

ILS -- Axial CMC Tube Tensile Test

Appendix E5 – Excel Data Spread Sheet (ATTDataSheet.xls) for ATT tests

CMC Axial Tube Tensile ILS

Tube Tensile Test Report

Date

There are five sections in this Tube Tensile data report

Section A = Contact information

Section E = Tensile Test Data

Section B = Test & Equipment Information

Section F = Post-Test Specimen Dimensions

Section C = Material Description

Section G = Calculated Stresses

Section D = Test Specimen Size Information

Please fill in these data sections electronically, providing all the required information and any optional information if it is available

This is a printout of the Excel spread sheet. Please record the data electronically on the spread sheet.

The enclosed CD contains the spread sheet in Excel.

Do not write the data on this printout.

The schedule for completing the testing and returning the data and samples is Month DD, YYYY

When the tests and data records are complete, send the following items to

- 1 The broken test pieces in their original packaging and the check lists to --
- 2 E-Mail the completed spread sheet file and the load-displacement curves.

Gateway Materials Technology
ATTN: Steve Gonczy
221 S. Emerson
Mt. Prospect, IL 60056

Admin Contact for Axial Tube Tensile Tests =

Stephen T. Gonczy, 847-870-1621,
E-Mail = gatewaymt@aol.com

Tech Contact for Tube Tensile Tests =

Yutai Katoh, 865-576-5996
E-mail: katohy@ornl.gov

Section A	Contact Information	Axial Tube Tensile DATA
	Lab Name & Location	
	Lab Contact Name	
	Contact Phone Number	
	E-Mail Address	

Section B	General Test & Equipment Description	TEST AND EQUIPMENT DATA	Units	Priority
1	Test Date		Alpha	Required
2	Lab Name and Location		Alpha	Required
3	Test Operator		Alpha	Required
4	CMC Description	SiC-SiC Composite tubes - biaxial braiding of Hi-Nicalon SiC fibers (multilayer PyC interface) with CVI SiC matrix	Alpha	Required
5	Sample Geometry	ORNL Tapered Tube 5" long tube with 1 degree tapered shoulders.	Alpha	Required
6	End Plug Description	Graphite End Plugs	Alpha	Required
6	End Collar Description	None	Alpha	Required
7	Specimen Conditioning	None	Alpha	Required
7	Specimen Machining	Done by RR-Hypertherm and by ORNL	Alpha	Required
8	Method of Specimen Storage		Alpha	Required
9	Test Machine Manufacturer		Alpha	Required
10	Test Machine Model #		Alpha	Required
11	Load Cell Capacity		kNewtons	Required
12	Load Cell Accuracy and Resolution		Newtons	Required
13	Grip Description	Split Collet Grips from ORNL	Alpha	Required
14	Load Train Coupler Description (Active or Passive)		Alpha	Required
15	Extensometer Description		Alpha	Required
15	Extensometer Gage Length and units		mm	Required
16	Strain Gage Description (Type, Count, Positions)		Alpha	Required
17	Test /Ambient Temperature		Degree C	Required
18	Ambient Humidity		% RH	Required
19	Test Control Mode		Alpha	Required
20	Test Displacement Rate		mm / sec	Required
21	Calculated Strain Rate		s ⁻¹	Required
22	Measured Average % Bending Stress, after Alignment		%	Required
23	Method of Data Collection		Alpha	Required
24	Data Collection Rate, Accuracy, and Resolution		Alpha	Required
25	Method of Determining Prop. Limit Stress (Offset Strain = 0.05 %)		Alpha	Required
26	Significant Deviations from Test Procedures		Alpha	Required

Section C	General Material Description	Test Specimen Data	Units	Priority
1	Material Identification Lot #	ORNL CMC Tube Set A	Alpha	Required
2	Material Description	SiC-SiC Braided CMC Tube	Alpha	Required
3	Nominal Test Specimen Dimensions	125 mm long, 14 mm OD, 10 mm ID	mm	Required
4	Orientation	Axial	Alpha	Required
5	# of Valid Tests		Numeric	Required
6	# of Invalid Tests		Numeric	Required
7	# of Censored Tests		Numeric	Required

Section D	Pretest Specimen Dimension DATA		Pretest OD 1A	Pretest OD 1B	Pretest OD 1C	Pos #1 Location	Pretest OD 2A	Pretest OD 2B	Pretest OD 2C	Pos #2 Location	Pretest OD 3A	Pretest OD 3B	Pretest OD 3C	Pos #3 Location	Average OD	Overall Length	Gage Length	Visual Inspect.	
			mm	mm	mm	mm	mm	mm	mm	mm	mm	mm	mm	mm	mm	mm	mm	mm	OK
Test #	Specimen ID #	Accuracy	xx.xx	xx.xx	xx.xx	Center Gage +25 mm	xx.xx	xx.xx	xx.xx	Center Gage	xx.xx	xx.xx	xx.xx	Center Gage -25 mm	xx.xx	xxx.	xxx	NOT OK	Alpha
1															#DIV/0!				
2															#DIV/0!				
3															#DIV/0!				
4															#DIV/0!				
5															#DIV/0!				
6															#DIV/0!				
7															#DIV/0!				
8															#DIV/0!				
9															#DIV/0!				
10															#DIV/0!				

Section E	Force and Strain Test DATA		Max. Breaking Force	Strain at Max Force	Prop. Limit Force	Prop. Limit Strain	Break Location	In Gage ??	Valid Test??
			Newtons	strain %	Newtons	strain %	Distance Up/Down from Gage Center (mm - U or D)	Yes	Tension Failure
Test #	Specimen ID #	Accuracy	xxxx.	x,xxx %	xxxx.	x,xxx %		No = Censored	Yes No
1	0								
2	0								
3	0								
4	0								
5	0								
6	0								
7	0								
8	0								
9	0								
10	0								

Section F	Post Test Specimen Dimension DATA		OD 4A	OD 4B	OD 4C	Aver. OD 4	Wall T1	Wall T2	Wall T3	Wall T4	Wall T5	Wall T6	Wall Thickness	Calc. Area	Pretest Aver. OD	% Delta Pretest/Post Test
			mm	mm	mm	mm	mm	mm	mm	mm	mm	mm	mm	mm	mm ²	mm
Test #	Specimen ID #	Accuracy	xx.xx	xx.xx	xx.xx	x.xx	x.xx	x.xx	x.xx	x.xx	x.xx	x.xx	x.xx	xxx.xx	xx.xx	
1	0					#DIV/0!							#DIV/0!	#DIV/0!	#DIV/0!	#DIV/0!
2	0					#DIV/0!							#DIV/0!	#DIV/0!	#DIV/0!	#DIV/0!
3	0					#DIV/0!							#DIV/0!	#DIV/0!	#DIV/0!	#DIV/0!
4	0					#DIV/0!							#DIV/0!	#DIV/0!	#DIV/0!	#DIV/0!
5	0					#DIV/0!							#DIV/0!	#DIV/0!	#DIV/0!	#DIV/0!
6	0					#DIV/0!							#DIV/0!	#DIV/0!	#DIV/0!	#DIV/0!
7	0					#DIV/0!							#DIV/0!	#DIV/0!	#DIV/0!	#DIV/0!
8	0					#DIV/0!							#DIV/0!	#DIV/0!	#DIV/0!	#DIV/0!
9	0					#DIV/0!							#DIV/0!	#DIV/0!	#DIV/0!	#DIV/0!
10	0					#DIV/0!							#DIV/0!	#DIV/0!	#DIV/0!	#DIV/0!

Report force, strain, and modulus to 4 significant figures.

Section G	Calculate Stress and Strain Test DATA		Ult. Tensile Strength	Strain at UTS	Tensile Elastic Modulus	Prop. Limit Stress	Strain at Prop. Limit Stress	Break Location	In Gage ??	Valid Test??	
			MPa	strain %	GPa	MPa	strain %			Yes	Tension Failure
Test #	Specimen ID #	Units Accuracy	xxx.x	x,xxx %	xxx.x	x,xxx %	x,xxx %	Distance Up/Down from Gage Center (mm - U or D)	No = Censored	Yes	No
1	0		#DIV/0!	0		#REF!	#REF!	0	0	0	0
2	0		#DIV/0!	0		#REF!	#REF!	0	0	0	0
3	0		#DIV/0!	0		#REF!	#REF!	0	0	0	0
4	0		#DIV/0!	0		#REF!	#REF!	0	0	0	0
5	0		#DIV/0!	0		#REF!	#REF!	0	0	0	0
6	0		#DIV/0!	0		#REF!	#REF!	0	0	0	0
7	0		#DIV/0!	0		#REF!	#REF!	0	0	0	0
8	0		#DIV/0!	0		#REF!	#REF!	0	0	0	0
9	0		#DIV/0!	0		#REF!	#REF!	0	0	0	0

Appendix E6 – Su et al. presentation on ORNL lead testing

Experimental design

- Copper split collets
- See ASTM C1773-13

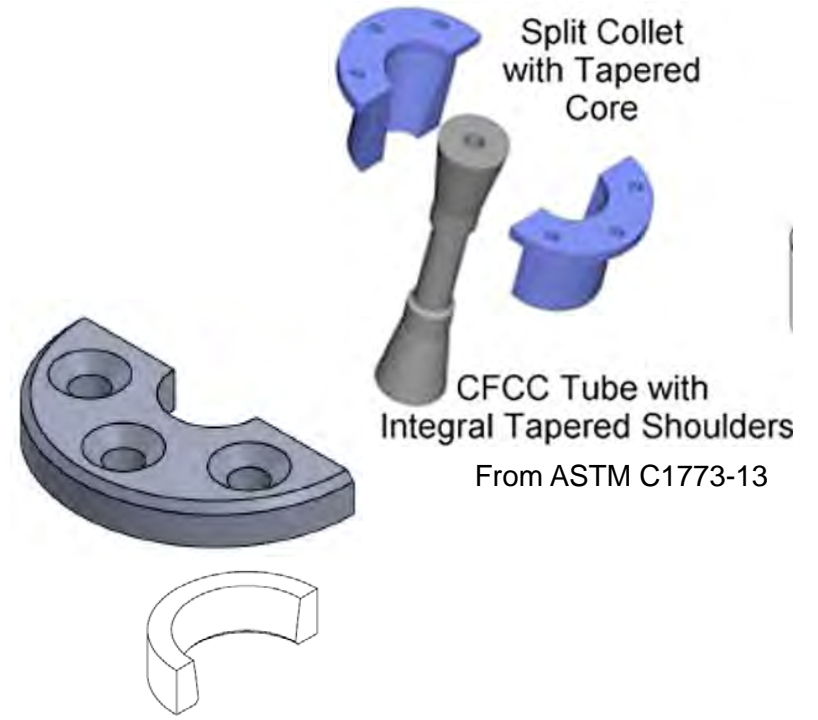
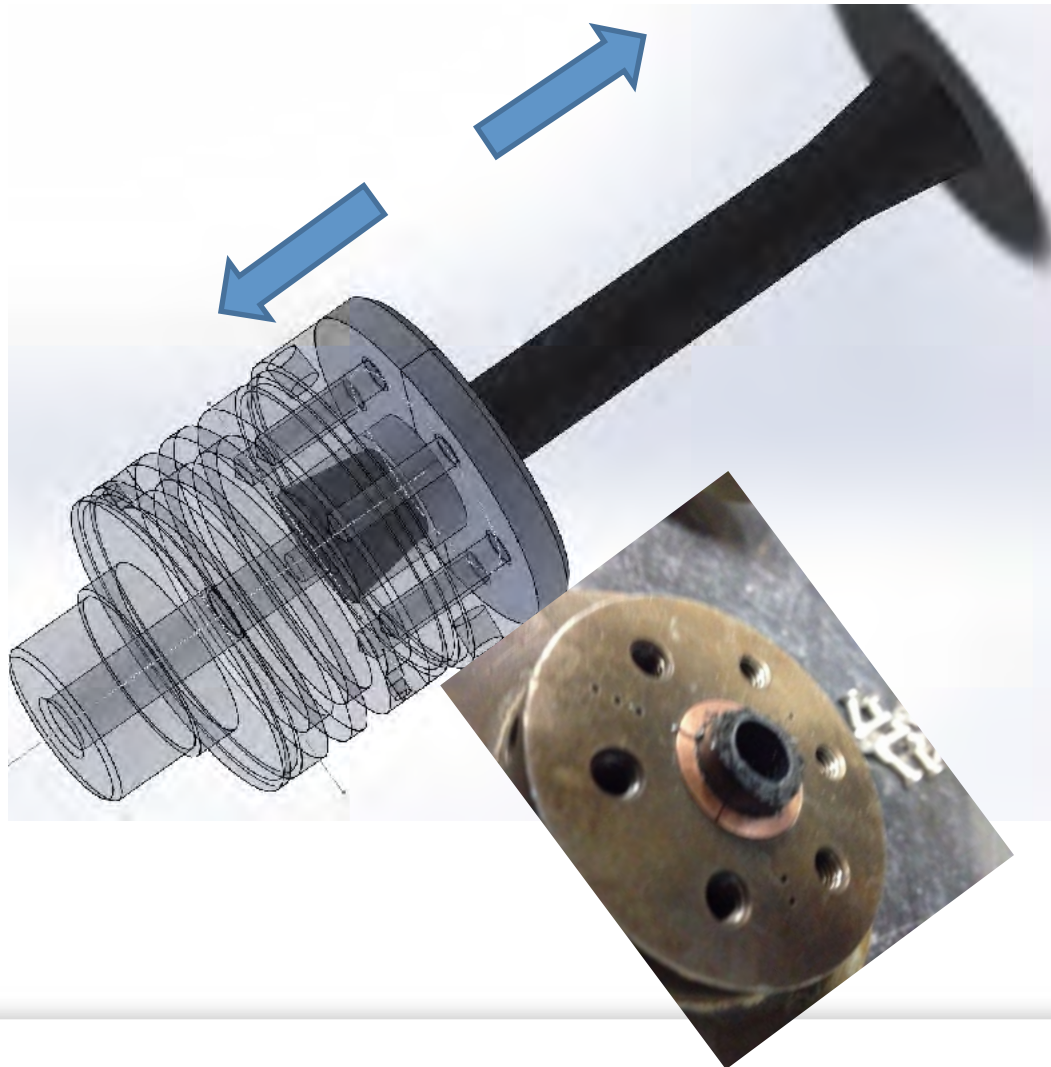

Tubular Test Specimen with Tapered Shoulders

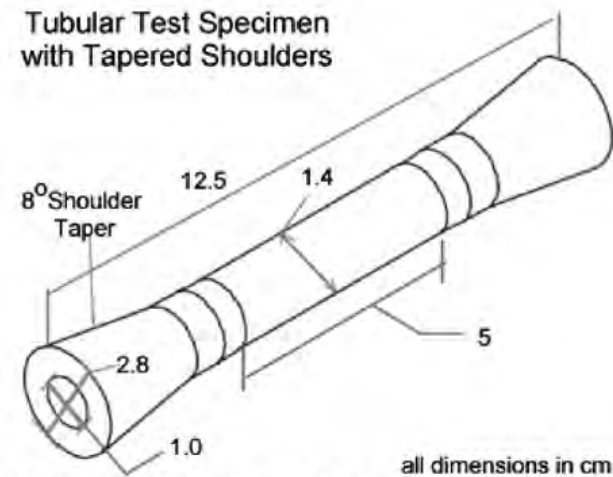

FIG. A2.4 Example of a Contoured Gage Tube Test Specimen with Tapered Shoulders (7)

Experimental set up

- Test frame, fixture, extensometer and researcher



Result: Fracture surface SEM

- Long Fiber pull out length
 - Dissipation of energy during fracture

Cut-Opened flat sample

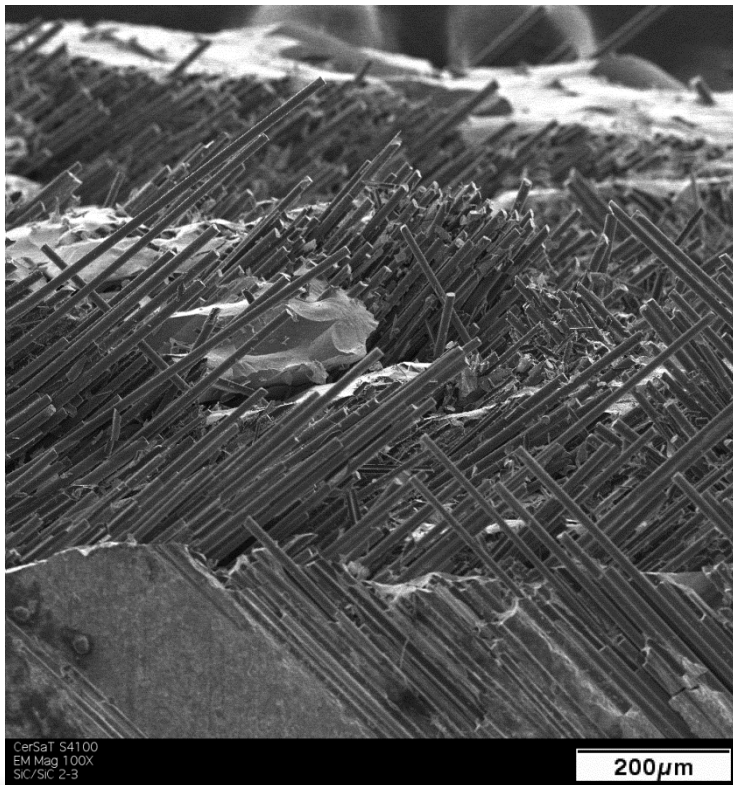

Tube

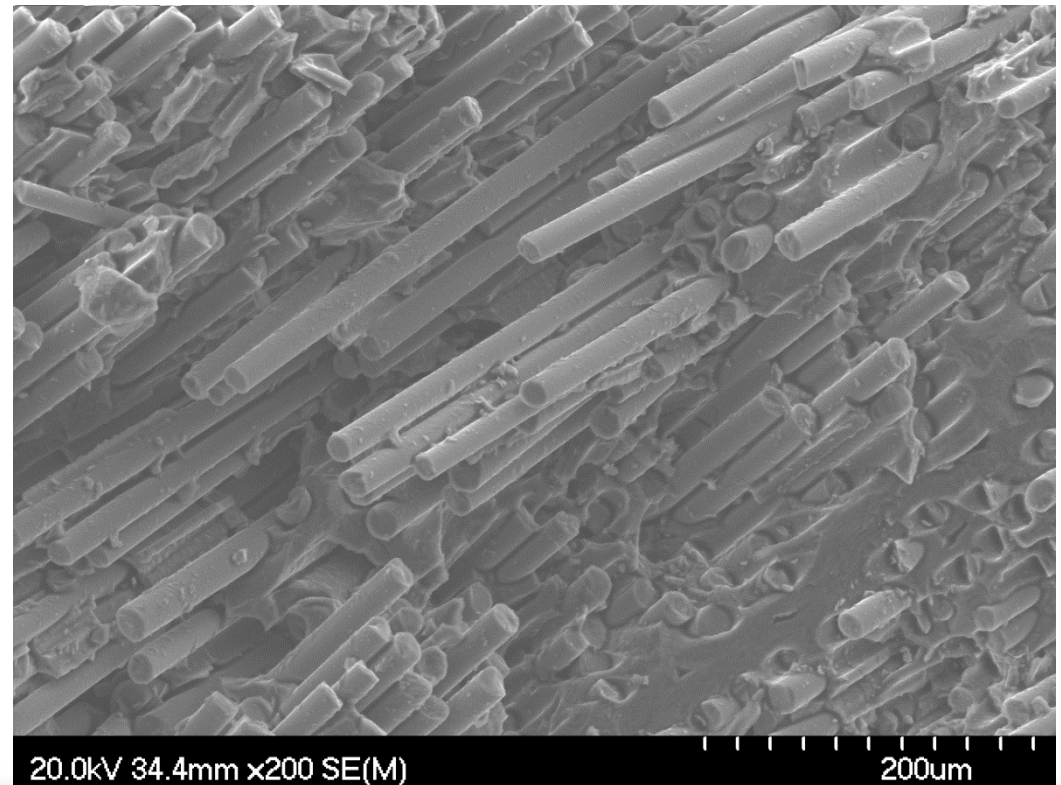

Tube tensile test result summary

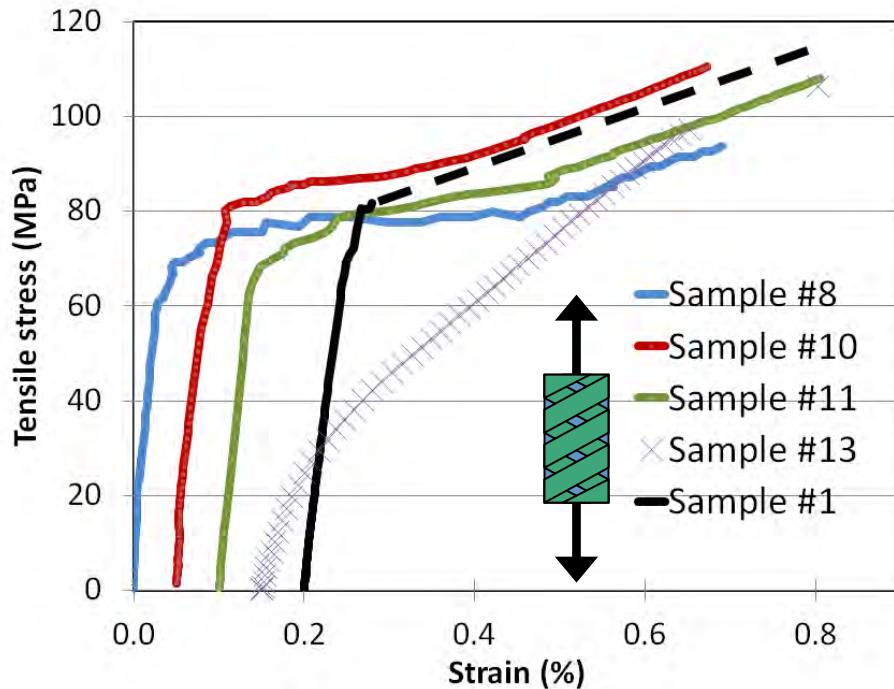

- Failure behavior reproducible. Failure stress consistent
- Well defined proportional limit stress
- Load to 80~90% failure load twice doesn't affect UTS much

ID #	PLS MPa	UTS MPa	Strain %	Modules GPa	Failure
8	67	94	0.69	226	
10	78	111	0.62	262	
11	66	108	0.70	166	
1	80	118	-	155	
13	-	106	0.65	-	
Avg	73	107	0.67	202	
Std	6.3	7.9	0.03	43.7	