

Light Water Reactor Sustainability Program

Assessing the Impact of the Inflation Reduction Act on Nuclear Plant Power Uprate and Hydrogen Cogeneration



September 2023

U.S. Department of Energy

Office of Nuclear Energy

DISCLAIMER

This information was prepared as an account of work sponsored by an agency of the U.S. Government. Neither the U.S. Government nor any agency thereof, nor any of their employees, makes any warranty, expressed or implied, or assumes any legal liability or responsibility for the accuracy, completeness, or usefulness, of any information, apparatus, product, or process disclosed, or represents that its use would not infringe privately owned rights. References herein to any specific commercial product, process, or service by trade name, trademark, manufacturer, or otherwise, does not necessarily constitute or imply its endorsement, recommendation, or favoring by the U.S. Government or any agency thereof. The views and opinions of authors expressed herein do not necessarily state or reflect those of the U.S. Government or any agency thereof.

Assessing the Impact of the Inflation Reduction Act on Nuclear Plant Power Uprate and Hydrogen Cogeneration

**Levi M. Larsen, Fredrick Joseck, Daniel Wendt, Yong-Joon Choi, Svetlana
Lawrance
Idaho National Laboratory**

**Wesley Price, Matt Greschuk, Eric Federline, Pete Carlone, Cecile Dame, Marissa
Womble
MPR Associates**

August 2023

**Prepared for the
U.S. Department of Energy
Office of Nuclear Energy**

Page intentionally left blank

EXECUTIVE SUMMARY

On August 16, 2022, Congress passed the Inflation Reduction Act (IRA) to promote investment in new, carbon-free power generation and sustainable operation of existing carbon-free assets. Specifically, the IRA includes both a production tax credit (PTC – Section 45Y of the IRA) and an investment tax credit (ITC – Section 48E) which utilities may leverage to offset the costs of power uprate. Further, the IRA includes a provision (Section 45V) for a PTC associated with carbon-free hydrogen cogeneration. These tax credits, along with recent legislation efforts to decarbonize the country, have re-emphasized the importance of maintaining and optimizing the existing nuclear plant operating fleet. As a result, utilities are reexamining the possibility of uprating their existing nuclear assets to further maximize carbon-free electricity generation.

The market opportunity for power uprates and hydrogen cogeneration is emerging. Nuclear power plants (NPPs) have performed power uprates since the 1970s as a cost-effective option to generate increased power. Most of the currently operating U.S. nuclear plants have performed some type of power uprate. As a result, the process and typical impact of power uprate on plant system, structures, and components (SSCs) is well understood. This report identifies that there is still a significant amount of “untapped” power available - by uprating existing NPPs and provides reference data for which SSCs are likely to be impacted by power uprate. It estimates that there is roughly ~5,500 MWt of untapped power in the current operating boiling water reactor (BWR) fleet and ~13,000 MWt of untapped power in the current pressurized water reactor (PWR) fleet (see section 3.2 for context and citations).

This report includes a financial assessment of the decision to uprate given impacts such as IRA tax credits. Specifically, a financial modeling tool was developed to supplement plant-specific models, and a case study was documented that highlights the impact of tax credits on the profitability of uprating a hypothetical plant. Figure 1 highlights one of the results from this case study and contextualizes the discussed tax credits by showing their impact on the newly produced levelized cost of energy (LCOE). More specifically, it suggests that utilities should be deliberate in their decision to elect an ITC or a PTC as one may provide a greater return (represented in the form of a lower LCOE) depending on uprate costs (see section 5.3 for context and citations).



Figure 1. Impacts to LCOE from uprate cost and tax credits.

Unlike power uprate, hydrogen cogeneration with a NPP is a relatively new concept with initial pilot efforts underway. However, there is growing interest in the production and use of zero-carbon hydrogen for hydrogen demand applications and as an alternative energy carrier to displace fossil fuels generated hydrogen for applications that cannot be easily electrified or decarbonized, and to provide a cost-effective approach for bulk long-term energy storage. While this zero-carbon hydrogen market is still emerging, the current outlook is favorable with potential for clean hydrogen demand to grow by an 900% (this represents an upper bound demand increase) by 2050 (see section 3.3 for context and citations).

The modeling performed also shows the financial impacts of hydrogen cogeneration by exploring when producing hydrogen is more profitable than producing electricity. Figure 2 shows these results. The modeling suggest that, for utilities with relatively lower power prices, hydrogen cogeneration could result in higher returns. However, as the potential price of electricity increases, hydrogen cogeneration becomes a less favorable option (see section 5.3 for context and citations).

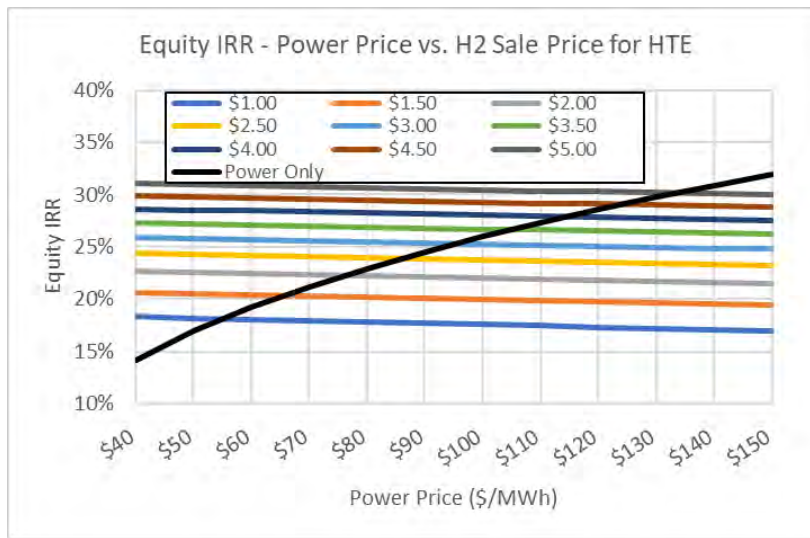

Figure 2. Impacts to profitability from power price changes and hydrogen prices.

This is taken a step further and modeling is done to estimate if clean hydrogen can be produced at a competitive price point relative to the current, predominate hydrogen generation methods. In Figure 3, the relationship between natural gas price and hydrogen produced via steam methane reforming (SMR) of natural gas. Currently, over 90% of the hydrogen produced in the US is generated from SMR of fossil-based natural gas. This is used as a means of benchmarking clean hydrogen produced from an electrolysis plant connected to a NPP. The resulting levelized cost of hydrogen (LCOH) projections suggest that clean hydrogen would be competitive with almost all natural gas prices shown.

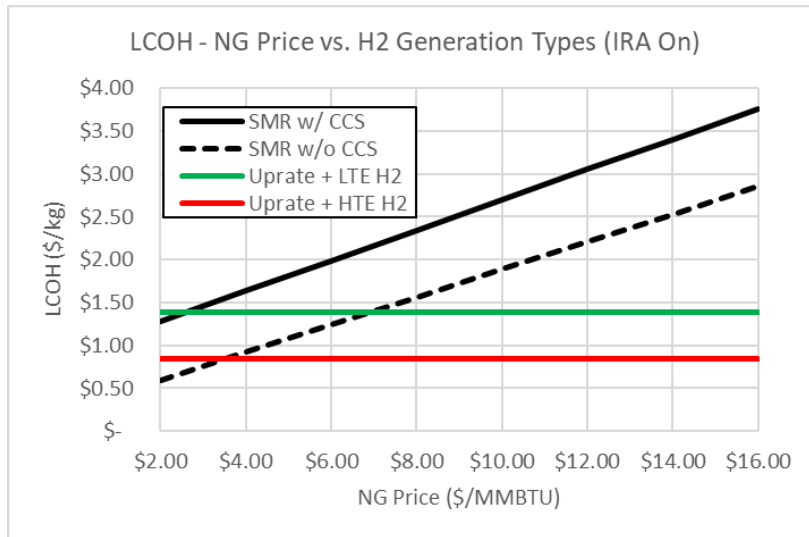

Figure 3. Impacts to SMR LCOH from changes in natural gas, benchmarked against clean LCOH.

Additionally, this report evaluates safety assessments required to support sizable power uprates. The historical uprates relied mostly on the already available safety margins to demonstrate that plant modifications due to power uprates do not affect the overall plant safety. For many plants, the remaining safety margins, as currently assessed, are not large-enough to support additional power uprates on the scale larger than a few percent. However, latest developments and advancements in computational resources and technologies, including modern data analytics technologies such as artificial intelligence and machine learning, allow to dramatically improve modeling and simulations of plant operations and underlying physics-based processes. This results in a much better understanding and representation of scenarios that may occur at an NPP. The advanced, more detailed modeling and simulations of NPP scenarios remove unnecessary conservatism typically imbedded in most of the analyses and demonstrate improved, i.e., larger, safety margins directly supporting larger power uprates.

Ultimately, operating nuclear power plants have an unprecedented opportunity to increase and diversify their revenue through incentives created by the Inflation Reduction Act. This, coupled with substantial technological advancements in hydrogen generation using electrolysis further warrants the need to evaluate clean hydrogen cogeneration. While financially important for individual utilities, this opportunity is imperative to national goals for decarbonizing energy section while making it more resilient and independent. This is especially true since power uprates can be achieved in the very near term, well-before new reactors are fully-developed, deployed, and connected to the grid.

ACKNOWLEDGEMENTS

The authors would like to acknowledge support of this project provided by Nuclear Energy Institute for providing valuable subject matter expertise. We especially appreciate the time and expertise of Aladar Csontos and Jonathan Rund. The authors also thank the valuable feedback from the several U.S. utilities that provided feedback on the modeling that went into this report.

CONTENTS

EXECUTIVE SUMMARY	vi
ACRONYMS	xvi
1. INTRODUCTION	1
2. POWER UPRATE BACKGROUND	1
2.1 Power Uprate Process Overview	1
2.1.1 Feasibility Study	1
2.1.2 Project Initialization	2
2.1.3 Analysis and Design Work	2
2.1.4 Licensing	2
2.1.5 Implementation	2
2.2 Types of Power Uprates	2
2.2.1 Measurement Uncertainty Recapture Power Uprate	2
2.2.2 Stretch Power Uprate	3
2.2.3 Extended Power Uprate	3
3. MARKET OVERVIEW	3
3.1 Overview of the Inflation Reduction Act of 2022	3
3.1.1 Zero-Emission Nuclear Production Credit for Existing Reactors (Section 45U)	3
3.1.2 Clean Electricity Production Credit (Section 45Y)	5
3.1.3 Clean Electricity Investment Credit (Section 48E)	7
3.1.4 Clean Hydrogen Production Credit (Section 45V)	7
3.1.5 Monetizing Tax Credits	8
3.2 Power Uprate Market Overview	9
3.2.1 Introduction	9
3.2.2 Current Power Uprate Industry Status	9
3.2.3 Power Uprate Market Opportunity	14
3.3 Hydrogen Market Overview	16
3.3.1 Introduction	16
3.3.2 Incentive for Generating Hydrogen with a Nuclear Plant	16
3.3.3 Current Hydrogen Production Industry Status	17
3.3.4 Hydrogen Market Opportunity	18
3.3.5 Conclusion	21
4. POWER UPRATE SYSTEM, STRUCTURE, AND COMPONENT ASSESSMENT	21
4.1 System, Structure, and Components Impacted by Power Uprate	21
4.2 Historical Power Uprate Financial Information	30
5. FINANCIAL MODEL DEVELOPMENT	33
5.1 Introduction	33
5.2 Financial Modeling Methodology	33
5.2.1 General Overview	33
5.2.2 Model Approach	34
5.2.3 Cashflow Model Methodology	36

5.3	Case Study.....	38
5.3.1	Overview.....	38
5.3.2	Inputs.....	39
5.3.3	Results.....	40
5.3.4	Sensitivity Analyses.....	43
6.	RISK-INFORMED SYSTEMS ANALYSIS	51
7.	SUMMARY	52
8.	REFERENCES	54
	APPENDIX A Model Sheets and Case Study Inputs	58
A-1.	MODEL SHEETS	58
A-1.1	Results Summary and Inputs Sheet.....	58
A-2.	ESCALATION INPUTS SHEET.....	58
A-2.1	Sensitivities Sheet	60
A-3.	CASE STUDY INPUTS.....	60
A-4.	APPENDIX A REFERENCES	64
	APPENDIX B Hydrogen Cogeneration.....	65
B-1.	LOW-TEMPERATURE ELECTROLYSIS.....	65
B-1.1	PEM Operating Principles	66
B-1.1.1	Technology Readiness Levels / Deployment Schedule	66
B-1.1.2	Performance and Cost Estimates.....	67
B-1.2	High-Temperature Electrolysis	68
B-1.2.1	SOEC Operating Principles	68
B-1.2.2	HTE Integration with Nuclear Power Plants.....	69
B-1.2.3	Technology Readiness Levels / Deployment Schedule	70
B-1.2.4	Performance and Cost Estimates.....	71
B-2.	APPENDIX B REFERENCES.....	75
	APPENDIX C Power Uprate and Nuclear Fuel.....	77
C-1.	HISTORICAL FUEL CONSIDERATIONS	77
C-2.	ADVANCED FUEL CONSIDERATIONS	78
C-3.	APPENDIX C REFERENCES.....	80
	APPENDIX D SAFETY ASSESSMENTS OF POWER UPDATES	81
D-1.	INTRODUCTION.....	81
D-2.	TECHNICAL BACKGROUNDS	82
D-2.1	Technical Issues in Power Uprate	82

D-2.2	Physics-Based Aspects in Power Uprate.....	82
D-2.3	Accident Tolerant Fuels	83
D-2.4	Core Configuration	83
	D-2.4.1 Operational and Safety Constraints.....	84
	D-2.4.2 Reactivity Compensation for FeCrAl-Clad Fuel.....	84
D-2.5	Safety Aspects in Power Uprate.....	85
	D-2.5.1 Best-Estimate Plus Uncertainties (BEPU)	85
	D-2.5.2 Analysis of Normal Operation and Operational Transients – Condition I.....	86
	D-2.5.3 Analysis of Chapter 15 Accidents – Conditions II, III, and IV.....	87
	D-2.5.4 Analysis of the Severe Accident (Beyond DBA).....	90
D-2.6	Computational Tools.....	90
	D-2.6.1 PARCS	90
	D-2.6.2 RELAP5-3D.....	90
	D-2.6.3 FAST.....	91
	D-2.6.4 RAVEN.....	91
	D-2.6.5 MELCOR.....	91
D-2.7	POWER UPRATE DEMONSTRATION.....	91
D-2.8	AI-Based Core Design	93
D-2.9	Safety Analysis	94
	D-2.9.1 Power Uprate with ZR Cladding Fuel.....	95
	D-2.9.2 Power Uprate with ATF Cladding Fuel: Steady-State Normal Operation.....	95
	D-2.9.3 Power Uprate with ATF Cladding Fuel: Anticipated Operational Occurrences.....	95
	D-2.9.4 Power Uprate with ATF Cladding Fuel: Transients and Design Basis Accidents....	95
	D-2.9.5 Power Uprate with ATF Cladding Fuel: Beyond Design Basis Accident	96
D-2.10	Fuel Performance Analysis.....	96
D-2.11	Source Term Analysis	96
D-3.	SUMMARY	98
D-4.	TIMELINE OF THE POWER UPRATE DEMONSTRATION.....	99
D-5.	TECHNICAL GAPS IN COMPUTATIONAL TOOLS AND MODELING	100
D-6.	APPENDIX D REFERENCES	101

FIGURES

Figure 1.	Impacts to LCOE from uprate cost and tax credits.....	vi
Figure 2.	Impacts to profitability from power price changes and hydrogen prices.	vii
Figure 3.	Impacts to SMR LCOH from changes in natural gas, benchmarked against clean LCOH.	viii
Figure 4.	Section 45U tax credit amount.	4
Figure 5.	Section 45U gross receipts.	4
Figure 6.	CLTP for operational BWRs in the United States (<i>dashed line indicates average CLTP</i>).	11
Figure 7.	CLTP for operational PWRs in the United States (<i>dashed line indicates average</i>).	11

Figure 8. Total percent uprate for operational BWRs in the United States beyond OLTP (<i>dashed line indicates average</i>).	12
Figure 9. Total percent uprate for operational PWRs in the United States beyond OLTP (<i>dashed line indicates average</i>).	12
Figure 10. Total percent uprate for plants in merchant markets (<i>dashed line represents average</i>).	13
Figure 11. Total percent uprate for plants in regulated markets (<i>dashed line represents average</i>).	14
Figure 12. Percentage uprate in BWR plants based on NSSS design type.	15
Figure 13. Percent uprate in PWR plants based on NSSS design type.	16
Figure 14. Hydrogen consumption breakdown in the United States in 2020, by sector.	18
Figure 15. Potential U.S. clean hydrogen consumption by sector in 2050.	19
Figure 16. Clean hydrogen 2050 demand curve.	20
Figure 17. Financial model flow chart.	36
Figure 18. Summary of capital costs (\$000s), project IRR, LCOE, and LCOH.	42
Figure 19. Case Study Sensitivity 1.	43
Figure 20. Case Study Sensitivity 2.	44
Figure 21. Case Study Sensitivity 3.	45
Figure 22. Case Study Sensitivity 4.	46
Figure 23. Case Study Sensitivity 7—no IRA.	47
Figure 24. Case Study Sensitivity 7—IRA.	47
Figure 25. Case Study Sensitivity 8.	48
Figure 26. Case Study Sensitivity 9.	49
Figure 27. Case Study Sensitivity 10.	49
Figure A-1. Example project spend curve.	59
Figure B-1. Comparison of electrical and heat duties for proven and advanced electrolysis options. [4]	65
Figure B-2. PEM electrochemical cell configuration. [6].....	66
Figure B-3. Solid oxide electrochemical cell configuration.[6].....	68
Figure B-4. Simplified HTE process flow diagram.	69
Figure B-5. Heat and electricity delivery from a LWR NPP to a high-temperature SOEC electrolysis plant. [4]	70
Figure B-6. Total manufacturing cost of solid oxide electrolysis stack using hydrogen electrode-supported cell construction. [30]	72
Figure B-7. FOAK (left) and NOAK (right) HTE plant capital costs as function of plant capacity.	73
Figure B-8. FOAK (left) and NOAK (right) HTE plant fixed and variable operating and maintenance costs as function of plant capacity.....	74
Figure D-1. Quarter symmetric of the 17 × 17 (left) and 21 × 21 (right) fuel assembly.	85

Figure D-2. Safety margins with conservative and BEPU calculations. [14].....	86
Figure D-3. High-level flow chart of LWRs-developed fuel reload optimization platform.	93
Figure D-4. RELAP5-3D nodalization for IGPWR.....	94

TABLES

Table 1. Example credit allocation.	6
Table 2. Estimate of untapped power from the U.S. PWR fleet.	15
Table 3. Summary of current U.S. nuclear plant hydrogen pilots.....	17
Table 4. Projected industry-specific demand by 2050 and required threshold prices.....	19
Table 5. SSCs impacted by power uprate.	23
Table 6. Survey of recent EPU experience for BWRs.	26
Table 7. Survey of recent EPU experience for PWRs.	28
Table 8. Power uprate historical costs.	31
Table 9. Financial model scenarios.....	34
Table 10. Model annual cashflow components.....	36
Table 11. Case study key inputs.....	39
Table 12. Case study IRA tax questions.	39
Table 13. Case study summary of results—IRR, capital costs, LCOE, and LCOH.	41
Table 14. Case Study Summary of Results—PVRR.	42
Table 16. List and requirements for normal operation.....	52
Table A-1. Sample escalation rate basis.	59
Table A-2. Model sensitivities.....	60
Table A-3. Case study key project inputs.	60
Table A-4. Case study key financial inputs.	61
Table A-5. Case study other inputs—uprate project.....	62
Table A-6. Case Study—Other Inputs—H ₂ Facility.....	63
Table B-1. List of PEM manufacturers and electrolyzer products.....	66
Table B-2. PEM system performance and cost specifications.	67
Table B-3. Indirect cost multipliers.	73
Table B-4. SOEC system performance and cost specifications.....	74
Table C-1. 2021 fuel cost summary.....	77
Table D-1. FeCrAl alloy iterations for nuclear applications.....	83
Table D-2. Core design parameter limits.	84
Table D-3. Case studies to compensate FeCrAl reactivity penalty.....	85

Table D-4. List and requirements of Condition I operation NOO scenarios.	87
Table D-5. Major design parameters of IGPWR.	92
Table D-6. Radionuclide groups in source term.	97
Table D-7. Source term release limitation to the containment in PWR DBAs.	97

ACRONYMS

ATF	accident-tolerant fuel
BWR	boiling-water reactor
CLTP	current licensed thermal power
DOE	Department of Energy
EPU	extended power uprate
FCEV	fuel cell electric vehicles
FWH	feedwater heaters
GHG	greenhouse gas
HP	high pressure
HTE	high-temperature electrolysis
INL	Idaho National Laboratory
IRA	Inflation Reduction Act
IRS	Internal Revenue Service
ITC	investment tax credit
LEU	low-enriched uranium
LP	low pressure
LTE	low-temperature electrolysis
LWRS	Light Water Reactor Sustainability
MSR	moisture separator reheaters
MUR	measurement uncertainty recapture power uprate
NEI	Nuclear Energy Institute
NPP	nuclear power plant
NRC	Nuclear Regulatory Commission
NREL	National Renewable Energy Laboratory
NSSS	nuclear steam supply system
OLTP	original licensed thermal power
PTC	production tax credit
PWR	pressurized-water reactor
SPU	stretch power uprate
SSC	systems, structures, and components
ZEC	zero-emission credit

1. INTRODUCTION

Recent legislation efforts to decarbonize the country have re-emphasized the importance of maintaining and optimizing the existing nuclear plant operating fleet. As a result, utilities are reexamining the possibility of uprating their existing nuclear assets to further maximize the carbon-free electricity generation.

To promote investment in new carbon-free power generation and sustainable operation of existing carbon-free assets, Congress recently passed the Inflation Reduction Act (IRA), which provides tax credits that existing utilities can leverage to implement power uprates. Specifically, the IRA includes both a production tax credit (PTC—Section 45Y of the IRA) and an investment tax credit (ITC—Section 48E of the IRA), which utilities may leverage to offset the costs of power uprate. Further, the IRA includes a provision (Section 45V) for a PTC associated with carbon-free hydrogen cogeneration [1].

The Department of Energy (DOE) has tasked the Light Water Reactor Sustainability (LWRS) Program with an effort to demonstrate the value of increased power output from the current operating fleet with consideration of IRA tax credits. This report assesses the impact of the IRA for power uprates and hydrogen cogeneration for the existing domestic nuclear operating fleet. A financial model is developed and a case study is documented to demonstrate the value of the IRA to the nuclear industry and to support utilities in assessing the financial impact of uprating their existing NPPs. To supplement the financial assessment, this report also provides an overview of the market opportunity for power uprate and hydrogen cogeneration as well as the historical impact of power uprate on plant systems, structures, and components (SSCs).

2. POWER UPRATE BACKGROUND

2.1 Power Uprate Process Overview

Prior to detailing the market for, impact of, and financial assessment of power uprates, it is important to understand what a power uprate project entails. NPPs have been performing power uprates since the 1970s as a cost-effective option to generate increased power. Most of the currently operating U.S. nuclear plants have performed some type of power uprate (see Section 3.2.2). As a result, the process for evaluating traditional power uprates is well understood across the industry. Several useful documents have been published to provide guidelines and operational experience related to power uprates. These guidance documents include, but are not limited to, Nuclear Energy Institute (NEI) 08-10, Roadmap for Power Uprate Program Development and Implementation [2], and International Atomic Energy Agency No. NP-T-3.9, Power Uprate in Nuclear Power Plants: Guidelines and Experience [3]. The available reference documents are generally consistent with each other in their descriptions of the power uprate process. This overall process is summarized below.

2.1.1 Feasibility Study

The power uprate process typically begins with a feasibility study to establish the technical and financial viability of the uprate. Important considerations for the technical portion of the feasibility study include margin definition (including actual plant performance), review of regulatory requirements, and the interfaces with the electrical system infrastructure (i.e., electrical grid). The technical portion of the feasibility study typically also identifies various “pinch points” necessitating significant investments (i.e., plant modifications) to further increase power output. The output of the technical assessment is typically a range of power uprate levels (i.e., scenarios) to be further evaluated via a business case evaluation.

The business case determines the optimal power uprate level from the potential power uprate range through detailed financial and risk assessments. These assessments include parameters such as incremental costs associated with power uprate (through the technical assessment), increased generation from the uprate, remaining plant operational life, impact on outage duration to implement plant modifications, and typical financing details (e.g., interest and discount rates). The end result of the feasibility study is a formal approval of a financial investment decision to pursue power uprate to a certain power level. This report focuses on the business case for power uprate by providing utilities a tool to use for performing the financial analysis portion of the feasibility study with consideration of the IRA tax credits (Section 5).

2.1.2 Project Initialization

After the formal decision has been made for an NPP to pursue power uprate, the next step in the process is project mobilization. This phase includes formally defining the scope, deliverables, communication plan, procurement strategy, risk strategy, and quality requirements for the project. The organizational structure is established for the project, including necessary oversight.

2.1.3 Analysis and Design Work

Based on the results of the SSC assessment performed during the feasibility study, the next phase of the power uprate process is initiating detailed analytical studies and design work for the plant modifications needed for power uprate. The result of this phase is the finalized safety analysis and plant modification packages supporting the uprate. At this stage, the business case for power uprate may be reassessed with updated cost inputs.

2.1.4 Licensing

Since the power uprate will change the reactor's licensed power level, utilities are required to submit a license amendment request to the U.S. Nuclear Regulatory Commission (NRC). The license amendment process to change a plant's power level is governed by 10 CFR 50.90-92 (Amendment of License or Construction Permit at Request of Holder). Various guidance documents have been published to provide technical guidance to licensees applying for power uprates, including RS 001, which is the NRC review standard for extended power uprates (EPUs; [4]). The safety analysis and plant modification packages are provided to the NRC as part of the license amendment request package. The NRC conducts thorough reviews of the submitted information and, if all technical analyses and justifications are acceptable, approves the license amendment representing an increased plant power output.

2.1.5 Implementation

After the necessary modification packages have been developed and regulatory approval is granted, plant personnel begin to implement changes necessary to accommodate the increase in power level. The plant modifications may need to occur over multiple outages and, as a result some of the upgraded equipment, may need to run at the original licensed thermal power (OLTP) until the remaining modifications are implemented. Detailed implementation guidance covering areas such as outage planning, training and simulator upgrades, procedure updates, power ascension testing and monitoring, startup vibration monitoring, and thermal performance testing can be found in [2][3].

2.2 Types of Power Uprates

Three types of power uprate have historically been implemented in the U.S.: measurement uncertainty recapture power uprates (MURs), stretch power uprates (SPUs), and EPUs.

2.2.1 Measurement Uncertainty Recapture Power Uprate

MURs increase the licensed power level by up to 2% and are also often referred to as 10 CFR 50.62 Appendix K uprates. To account for uncertainty in measuring feedwater flow, 10 CFR 50.62 Appendix K required utilities to apply a 2% uncertainty factor to thermal power calculations used in safety analyses. Historically, plants have utilized ultrasonic feedwater flow measurement devices that provide more precise measurements of feedwater flow, and in turn allow utilities to claim a portion of the 2% uncertainty factor applied to thermal power calculations. There is a current industry effort to utilize data validation and reconciliation as a software-based alternative approach to the historical hardware-based solution. This approach is currently under NRC review. Finally, MURs typically do not require significant component upgrades other than new feedwater flow measurement devices and potential modifications to the high pressure (HP) turbine (level of modification dependent on available margin).

2.2.2 Stretch Power Uprate

SPUs typically increase power levels between 2% and 7% and are within the existing design margin of the plant. The achievable value for percentage increase in reactor power is plant specific and depends on the operating margins included in the design of a particular plant. SPUs typically require changes to instrument setpoints but generally do not involve significant plant modifications beyond potentially the HP turbine (and in some cases the main generator) depending on the existing margin.

2.2.3 Extended Power Uprate

EPU are greater increases in power than SPUs and have been approved for power increases as high as 20% the OLTP in the United States. In order to implement EPUs, steam flow is typically substantially increased (e.g., [5] states 20% above OLTP). The thermal power generated in the core must also be increased, which is accomplished by flattening the core power distribution. The core power distribution is typically adjusted by methods such as changing the radial and axial fuel loading patterns, control rod programs, and the distribution of burnable poisons. Similar methods are utilized to ensure that the core design provides sufficient operational flexibility (i.e., can provide baseload power but also respond to various grid demands) and reactivity characteristics. EPUs typically require significant modifications to the balance-of-plant equipment, such as HP turbines, condensate pumps and motors, main generators, and transformers. Additional detail on the impact of power uprates to plant SSCs is provided in Section 4.

3. MARKET OVERVIEW

3.1 Overview of the Inflation Reduction Act of 2022

The IRA was signed into law on August 16, 2022 [1]. It provides unprecedented federal investment towards energy security for the United States and is a further commitment from Congress to support clean energy. It contains substantial tax incentives for clean energy production and investment. These tax provisions recognize nuclear energy's essential role in reaching greenhouse gas (GHG) emission reduction targets and include a PTC for existing NPPs and technology-neutral credits for new and expanded production from and investment in clean energy facilities (such as power uprates at existing nuclear plants). The IRA also allows for greater monetization of those tax credits, as discussed in Section 3.1.5.

The following subsections provide an overview of the relevant tax credits for NPPs and hydrogen cogeneration. Note that the formal interpretation of how these credits will be applied is still being determined by the Department of Treasury (Treasury) and Internal Revenue Service (IRS) as of this issuance of this report. As such, the information contained herein is subject to change; however, the information below is considered a best estimate at this time according to NEI [6].

3.1.1 Zero-Emission Nuclear Production Credit for Existing Reactors (Section 45U)

To help preserve the existing fleet of NPPs, the IRA includes Internal Revenue Code Section 45U PTC for facilities that use nuclear energy to produce electricity and were placed in service before August 6, 2022. The credit is available for electricity produced and sold after December 31, 2023, and before December 31, 2032. Section 45U is not applicable to any facility considered an advanced nuclear power facility under Section 45J. The credit amount is calculated as shown in Figure 4.

Base Amount	0.3 cents × kWh of electricity produced by taxpayer and sold to an unrelated person
Less:	"reduction amount"
Equals:	Amount of section 45U Credit

The "reduction amount" is calculated as follows:

16% ×	$\left(\begin{array}{l} \text{Gross receipts from electricity produced by facility} \\ \text{(including electricity service or products provided} \\ \text{in conjunction therewith) and sold to unrelated person} \\ \text{(plus certain zero emission credit payments)} \\ \text{Less: } 2.5 \text{ cents * kWh energy produced and sold to unrelated person} \end{array} \right)$
Equals:	
	Reduction Amount

Figure 4. Section 45U tax credit amount.

If the "reduction amount" would cause the Section 45U credit amount, as calculated above, to go below zero, the amount of the credit is zero. The amount of the credit calculated above is multiplied by five if prevailing wage requirements [8] are satisfied. Both the 0.3 cents per kWh and 2.5 cents per kWh amounts in the formula in Figure 4 are indexed for inflation using the gross domestic product (GDP) implicit price deflator and Calendar Year 2023 as the base year.

Based on the above formula, if prevailing wage requirements are met, Section 45U provides a \$15/MWh per reactor credit when gross receipts are up to \$25/MWh in 2023 dollars. As illustrated in Figure 5, the credit is reduced when the reactor's gross receipts exceed \$25/MWh such that the credit is completely phased out if the reactor receives \$43.75/MWh or more in gross receipts.

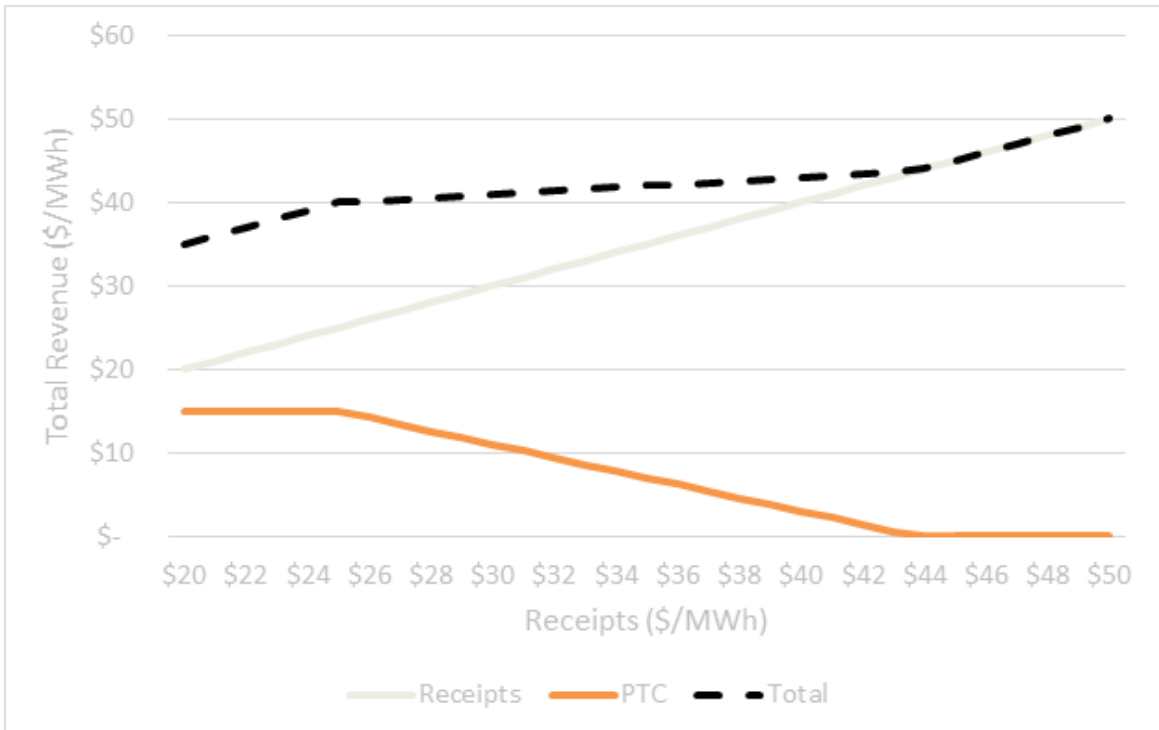

Figure 5. Section 45U gross receipts.

Gross receipts include any amount received with respect to the qualified nuclear power facility from a zero-emission credit (ZEC) program. However, amounts received from a ZEC program are excluded from the gross receipts amount if the full amount of the credit is used to reduce payments from such ZEC program.

Because the base credit amount is decreased by a “reduction amount” that is calculated, in part, based on the gross receipts from any electricity produced by such facility, further Treasury and IRS guidance for determining gross receipts will be critical to calculating the amount of credit available under Section 45U.

3.1.2 Clean Electricity Production Credit (Section 45Y)

The IRA establishes a new technology-neutral PTC for electric generation facilities that have zero GHG emissions and are placed in service after Dec. 31, 2024. The credit phases down to zero over 3 years beginning with the second calendar year after the year the Treasury Secretary determines the annual U.S. GHG emissions from electricity production is equal or less than 25% of GHG emissions in 2022 or 2032, whichever is later. Therefore, if the applicable year is 2032, the full credit amount would be available for 2033, the credit would be reduced to 75% in 2034, 50% in 2035, and 0% in 2036. Qualified facilities would be “locked-in” to the credit amount they qualify for the year construction begins on the electric generation facility. Most projections, however, show that annual U.S. GHG emissions from electricity production will decrease to 25% of 2022 emission levels later (potentially much later) than 2032.

Qualified facilities are eligible for the Section 45Y credit for the first 10 years after the facility is placed in service. To be considered a qualified facility, the facility must be owned by the taxpayer, used for generation of electricity, placed in service after Dec. 31, 2024, and have a GHG emissions rate under zero. Note emissions rate in this context refers only to GHGs emitted into the atmosphere by the facility in the production of electricity not life-cycle emissions, such as those resulting from the construction of the facility and its components or production of its fuel. A qualified facility does not include any facility for which a credit determined under Section 45J, 45U, or 48E was allowed (i.e., claimed) for the taxable year or any prior taxable year. Thus, a taxpayer has the option to choose between the clean electricity PTC or ITC (Section 48E) but cannot choose both for the same facility.

Under Section 45Y(b)(1)(C), a qualified facility includes additions to a facility placed in service before Jan. 1, 2025, if the increased amount of electricity produced at the facility is due to a new unit placed in service after Dec. 31, 2024, or any additional capacity placed in service after Dec. 31, 2024. In enacting this provision, Congress established a mechanism to incentivize new units and added capacity at power plants that were operating before 2025, including existing nuclear facilities. Treasury and IRS guidance is expected to clarify that additional capacity placed in service after Dec. 31, 2024, qualifies as a separate facility for the purposes of Section 45Y, and thus, incremental production from an uprated facility is eligible for the Section 45Y credit, even if the existing facility claimed the Section 45U or 45J credit.

Guidance is needed to provide acceptable means to determine how much of a facility’s annual electricity generation is the result of a capacity addition under Section 45Y, and how much is attributable to the facility as it existed before the capacity addition was placed in service. NEI and others have proposed that guidance include several reasonable methods for allocating electricity production to capacity additions. Reasonable methods would include using the ratio of incremental increased capacity to the previous capacity to allocate annual generation between the new facility and the facility as it existed prior to the capacity addition. It is expected that the credit could be claimed multiple times over its eligible applicable period if an existing facility pursues multiple, incremental capacity increases over that time period. Table 1 provides examples illustrating how the electric power production at an existing NPP would be allocated between the Section 45U and 45Y credit following an increase in capacity factor only, an increase in nameplate capacity (e.g., associated with a power uprate), and the combination of an increase in capacity factor and in nameplate capacity.

Table 1. Example credit allocation.

Example (capacity factor)	Nameplate Capacity (ratio of new to total capacity)	Total Generation and Credit Allocation
Baseline (90%)	900 MW	7,095,600 MWh/year All allocated for § 45U
No Uprate (93%)	900 MW (no capacity addition)	7,332,120 MWh/year All allocated for § 45U
100 MW Uprate (90%)	1,000 MW (0.10)	7,884,000 MWh/year 7,095,600 MWh/year for § 45U + 788,400 MWh/year for § 45Y
100 MW Uprate (93%)	1,000 MW (0.10)	8,146,800 MWh/year 7,332,120 MWh/year for § 45U + 814,680 MWh/year for § 45Y

The credit amount equals 0.3 cents per kWh (\$3/MWh) (indexed for inflation using the GDP implicit price deflator from 1992) for electricity produced and sold to an unrelated person (or if equipped with a metering device owned and operated by an unrelated person, sold, consumed, or stored by taxpayer). The amount of the credit calculated above is multiplied by five if prevailing wage and apprenticeship requirements [8] are satisfied. Thus, if prevailing wage and apprenticeship requirements are met, the value of the Section 45Y credit is expected to be about \$30/MWh in 2025 (0.3 cents per kWh ratioed by GDP implicit price deflator from 1992 to 2025 times five for meeting wage and apprenticeship requirements).

The Section 45Y credit is increased by 10% if the facility is in an “energy community,” and by another 10% if “domestic content” requirements are met (see descriptions in the next two paragraphs). Thus, if the requirements for both bonuses were met (along with prevailing wage and apprenticeship requirements), the value of the Section 45Y credit would be about \$36/MWh in 2025.

An “energy community” includes:

- A brownfield site as defined in the Comprehensive Environmental Response, Compensation, and Liability Act
- A metropolitan statistical area or nonmetropolitan statistical area that has (or after Dec. 31, 2009, had) 0.17% or greater direct employment or 25% or greater local tax revenues related to extracting, processing, transporting, or storing of coal, oil, or natural gas and has an unemployment rate at or above the national average rate for previous year
- A census tract (or adjoining tract) in which a coal mine closed after Dec. 31, 1999 or a coal-fired electric generating unit retired after Dec. 31, 2009 (additional guidance provided by the IRS in Notices 2023-29 and 2023-45).

The domestic content requirement is satisfied if the taxpayer certifies that any steel, iron, or manufactured product that is a component of such a facility (upon completion of construction) was produced in the United States. For cases involving additional capacity to existing facilities, this is expected to only apply to the “new” materials required for the additional capacity (i.e., not the existing plant materials). Manufactured components of a qualified facility after construction are produced in the United States if at least the adjusted percentage of the total costs of all such manufactured products of the facility are from manufactured products (including components) that are mined, produced, or manufactured in the United States. The adjusted percentage is 40% if construction begins before 2025, 45% if construction begins in 2025, 50% if construction begins in 2026, and 55% if construction begins after 2026. Additional guidance has been provided by the IRS in Notice 2023-38.

Finally, the Section 45Y credit has provisions that apply rules similar to those of Section 45(b)(3), which requires a reduction of the credit if tax-exempt bonds are used to finance the facility. The reduction is 15% or

the fraction of the proceeds of the tax-exempt bond used to provide financing for the facility over the aggregate amount of additions to the capital account for the qualified facility, whichever is lower.

3.1.3 Clean Electricity Investment Credit (Section 48E)

The IRA also establishes a new technology-neutral ITC for electric generation facilities that have zero GHG emissions and are placed in service after Dec. 31, 2024. Like the Section 45Y PTC, the Section 48E ITC phases down to zero over 3 years beginning with the second calendar year after the year the Treasury Secretary determines the annual U.S. GHG emissions from electricity production is equal or less than 25% of GHG emissions in 2022 or 2032, whichever is later. Therefore, if the applicable year is 2032, the full credit amount would be available for 2033, the credit would be reduced to 75% in 2034, 50% in 2035, and 0% in 2036. Most projections, however, show that annual U.S. GHG emissions from electricity production will decrease to 25% of 2022 emission levels later (potentially much later) than 2032.

Qualified facilities are eligible for the Section 48E ITC the year the facility is placed in service. To be considered a qualified facility, the facility must be owned by the taxpayer, used for electricity generation, placed in service after Dec. 31, 2024, have a GHG emissions rate that is less than zero, be tangible personal property or other tangible property (not including building or structural components) used as an integral part of the qualified facility, and be depreciable or amortizable. A qualified facility does not include any facility for which a credit determined under Section 45J, 45U, or 45Y was allowed for the taxable year or any prior taxable year. Thus, a taxpayer has the option to choose between the clean electricity PTC or ITC but cannot choose both for the same facility.

Under Section 48E(b)(3)(B)(i), a qualified facility includes additions to a facility placed in service before Jan. 1, 2025, if the increased amount of electricity produced at the facility is due to a new unit placed in service after Dec. 31, 2024, or any additional capacity placed in service after Dec. 31, 2024. Treasury and IRS guidance is expected to clarify that additional capacity placed in service after Dec. 31, 2024, qualifies as a separate facility for Section 48E purposes, and thus, an uprate investment is eligible for the Section 48E credit, even if the existing facility claimed the Section 45U or 45J credit (Section 45J is an advanced nuclear PTC that was enacted in 2005). Guidance may be needed to provide acceptable means to apportion investments that result in a capacity addition but also include other, perhaps significant, capital improvements (e.g., life-cycle management investments). Note it is expected that the credit could be claimed multiple times over its eligible applicable period if an existing facility pursues multiple, incremental capacity increases over that time period.

The Section 48E credit is equal to 6% of a qualified investment in any qualified facility and is increased to 30% if prevailing wage and apprenticeship requirements are met. Like the Section 45Y credit, the Section 48E credit may be increased by 10% if the facility is in an energy community and by another 10% if the domestic content standard is met. Thus, if the requirements for both bonuses were met (along with prevailing wage and apprenticeship requirements), the credit would be 50% of the qualified investment. Credits can be carried forward for up to 22 years; however, credits that are carried forward may not be transferred.

Finally, the Section 48E credit has the same provisions discussed for the Section 45Y credit regarding a reduction of the credit if tax-exempt bonds are used to finance the facility. The reduction is 15% or the fraction of the proceeds of the tax-exempt bond used to provide financing for the facility over the aggregate amount of additions to the capital account for the qualified facility, whichever is less.

3.1.4 Clean Hydrogen Production Credit (Section 45V)

Section 45V provides a tax credit for the production of qualified clean hydrogen beginning Jan. 1, 2023. To be eligible for the credit, clean hydrogen production facilities must be owned by the taxpayer, produce qualified clean hydrogen, and start construction of the facility before Jan. 1, 2033. The credit is available for the first 10 years after a facility is placed in service. Qualified clean hydrogen must be produced in the United States, in the ordinary course of a trade or business of the taxpayer, and in compliance with other requirements as determined by the Treasury Secretary. The hydrogen must be for sale or use as verified by an unrelated third party (e.g., third-party records indicating use or sale of hydrogen).

The availability and value of the credit depends upon the life-cycle GHG emissions rate that results from the facility's hydrogen production process. More stringent rates correspond to higher credit values. Qualified clean hydrogen is produced through a process that results in a life-cycle GHG emission of 4 kilograms or less of CO₂e per kilogram of hydrogen. Assuming the prevailing wage and apprenticeship requirements are met, the credit amount equals \$3.00 per kilogram of hydrogen multiplied by^a:

- 20% if the facility produces hydrogen that results in life-cycle GHG emissions between 2.5 and 4 kilograms of CO₂e per kilogram of hydrogen
- 25% if the facility produces hydrogen that results in life-cycle GHG emissions between 1.5 and 2.5 kilograms of CO₂e per kilogram of hydrogen
- 33.4% if the facility produces hydrogen that results in life-cycle GHG gas emissions between 0.45 and 1.5 kilograms of CO₂e per kilogram of hydrogen
- 100% if the facility produces hydrogen that results in life-cycle GHG gas emissions under 0.45 kilograms of CO₂e per kilogram of hydrogen.

It is expected that hydrogen produced using energy from a nuclear plant would result in a life-cycle GHG emission of less than 0.45 kg of CO₂e per kilogram of hydrogen, qualifying for the full \$3.00/kg [9]. Section 45V specifies that life-cycle GHG emissions “only include emissions through the point of production (well-to-gate)” as determined using the most recent “Greenhouse Gases, Regulated Emissions, and Energy Use in Transportation” model, developed by Argonne National Laboratory. Accordingly, it is critical to determine the life-cycle GHG emissions of the hydrogen production process, including how to evaluate electricity that powers that process regardless of whether it is procured from the grid or behind the meter. Guidance is expected to address these issues.

The Section 45U zero-emission nuclear PTC provides that existing nuclear plants are eligible to receive a credit under both Section 45U (for production of electricity) and Section 45V (for production of hydrogen) where electricity from the qualified nuclear facility is used at a qualified clean hydrogen production facility. Similarly, it is expected that existing nuclear plants are eligible to receive a credit under both Section 45Y (for production of additional capacity electricity) and Section 45V.

Finally, the Section 45V credit has the same provisions discussed for the Section 45Y and Section 45E credits regarding a reduction of the credit if tax-exempt bonds are used to finance the facility. The reduction is 15% or the fraction of the proceeds of the tax-exempt bond used to provide financing for the facility over the aggregate amount of additions to the capital account for the qualified facility, whichever is less.

3.1.5 Monetizing Tax Credits

The IRA introduced two additional options for entities that are unable to use tax credits to still receive benefits from them. These options should allow all entities to take advantage of the tax credits discussed above. Although the two new options described below should be effective for monetizing the tax credit, they do not provide for a monetization of the depreciation benefits.

Under the “direct pay” option, an entity is treated as having made a tax payment equal to the amount of such credit, such that the amount of such payment is available as a refund if such payments exceed the entity's tax liability. Direct pay is available to any tax-exempt entity, state, or local government (or political subdivision thereof), Tennessee Valley Authority, an Indian tribal government, any Alaska native corporation, or any corporation operating on a cooperative basis that is engaged in furnishing electric energy to rural areas. Additionally, before 2033, any taxpayer may elect direct payment for Section 45V (clean hydrogen production credit) for the taxable year equipment is placed in service as well as four subsequent years prior to 2033.

The amount of a direct payment may be reduced if domestic content requirements are not met. Direct payments are not subject to a reduction if facility construction began before Jan. 1, 2024. If the domestic content requirement is not satisfied, then any direct payment is subject to a 10% reduction for facilities that begin

^a If prevailing wage and apprenticeship requirements are not met, the \$3.00 base amount is reduced to \$0.60.

construction in 2024, a 15% reduction for facilities that begin construction in 2025, and a 100% reduction for facilities that begin construction in 2026 or later. There is an exception to the direct pay domestic content requirement if satisfying the requirement would increase costs by at least 25% or there are insufficient quantities or quality of required material related to the new facility.

Any taxpayer that is not entitled to direct payments is eligible to transfer the credits. A transfer election (made on a yearly basis) is available for an eligible taxpayer to transfer all (or any portion) of an eligible credit to an unrelated taxpayer, provided that consideration for such transfer is paid in cash. The amount of consideration received in exchange for any credit is not includible in gross income of the eligible taxpayer and is not deductible with respect to the transferee taxpayer. An election to transfer the credit must be made no later than the due date (including extensions) for the tax return in the year the credit is determined. The election can only be made once with respect to any portion of an eligible credit. The credit is taken into account in the first taxable year of the transferee taxpayer ending with, or after, the taxable year of the eligible taxpayer with respect to which the credit was determined. Further note that it is expected that selling the tax credits may result in a “haircut,” or reduction of the benefit. It is expected that this reduction would be on the order of 10% or less of the credit value.

3.2 Power Uprate Market Overview

3.2.1 Introduction

Significant power uprates (i.e., EPU) in the United States began in the late 1990s, with the majority finalized over a decade ago. Until recently, market conditions were not favorable for additional EPUs due to historically low natural gas prices and tax incentives for other clean energy sources (e.g., wind and solar). As a result, there have been a limited number of EPUs over the past decade with the majority of uprates implemented during this time being MURs (i.e., on the order of 1%–2% increases in power).

The IRA represents a major shift in the market outlook for U.S. nuclear plants due to the ability to claim technology-neutral credits (i.e., 45Y and 48E—see Section 3.1) for capacity increases from power uprates. Many of the historical financial barriers to power uprates (e.g., steam generator replacements for PWRs) may now be financially viable as a result of the IRA. Additionally, these favorable conditions for nuclear power are causing nuclear steam supply system (NSSS) vendors and nuclear fuel vendors to consider new analysis methods and technologies to uprate existing stations beyond historical maximums (e.g., 120% OLTP for BWRs). This includes considering new fuel technologies, such as accident-tolerant fuel (ATF) and low-enriched uranium plus (LEU+).

3.2.2 Current Power Uprate Industry Status

As of April 2023, the NRC has approved 171 power uprates, resulting in a gain of approximately 24,089 MWt. Collectively, these uprates added generating capacity equivalent to approximately eight new reactors [10]. The thermal power gained through power uprates for operating boiling-water reactors (BWRs) is shown in Figure 6. Similarly, Figure 7 shows the thermal power gained through power uprates for operating pressurized-water reactors (PWRs - note Vogtle 3 which commenced operation in 2023 is not included). Figure 8 and Figure 9 show the percentage uprate beyond OLTP for BWRs and PWRs.

Some of the key takeaways from these figures include:

- The average current licensed thermal power (CLTP) for operational BWRs is on average approximately 200 MWt higher than for PWRs. For comparison, the average OLTP for BWRs is smaller than for PWRs (approximately 30 MWt).
- One utility (with BWRs) has elected to perform MURs on top of a 120% OLTP EPU, which resulted in the highest percentage uprate from OLTP at approximately 122% OLTP.
- In total, BWRs have gained more than 13,000 MWt through power uprates, despite having approximately half of the number of reactors when compared to PWRs [10].
- This is driven by the fact that the NRC has approved a generic approach for BWR EPUs.

- General Electric (GE) Extended Power Uprate Licensing Topical Reports provide information regarding EPU scope, analysis codes and methods, assumptions, and other specific criteria. These reports are listed below for reference as cited in prior power uprate licensing documentation (e.g., [11]).
 - GE Nuclear Energy, “Constant Pressure Power Uprate,” NEDC-33004P-A, Revision 4, Class III (Proprietary), July 2003; and NEDO-33004, Class I (Non-proprietary), July 2003.
 - GE Nuclear Energy, “Generic Guidelines for General Electric Boiling Water Reactor Extended Power Uprate,” NEDC-32424P-A, Class III (Proprietary), February 1999; and NEDO-32424, Class I (Non-proprietary), April 1995.
 - GE Nuclear Energy, “Generic Evaluations of General Electric Boiling Water Reactor Extended Power Uprate,” NEDC-32523P-A, Class III (Proprietary), February 2000; NEDC-32523P-A, Supplement 1 Volume I, February 1999; and Supplement 1 Volume II, April 1999.
- BWRs are able to increase power up to 120% OLTP without significant modification to NSSS hardware (with the exception of steam dryer replacement) by increasing core flow along the maximum extended load line limit analysis rod line in a range of core flow from just less than rated core flow to the maximum licensed core flow.
- The average BWR uprate is approximately 114% OLTP, which is considerably higher than the average PWR uprate of 106% OLTP.
- PWRs have historically been limited in uprate capacity by steam generators. Many plants have chosen to limit power uprates to avoid making major modifications to steam generators due to cost and risk considerations.
- Further, analogous regulatory-approved approaches to the GE topical reports for BWRs have not been published for PWR EPUs.
- There are remaining opportunities to further uprate the BWR fleet. Eleven stations are operating with less than 107% OLTP.
- The opportunity to uprate the PWR fleet appears to be larger than the BWR fleet as only seven stations have achieved uprates in the 15%–20% range.
 - This is likely due to the limitations associated with needing steam generator replacements to operate at higher power levels.
 - Nevertheless, there are approximately 20 PWRs that have either not performed power uprates at all or have only pursued MURs to this point.

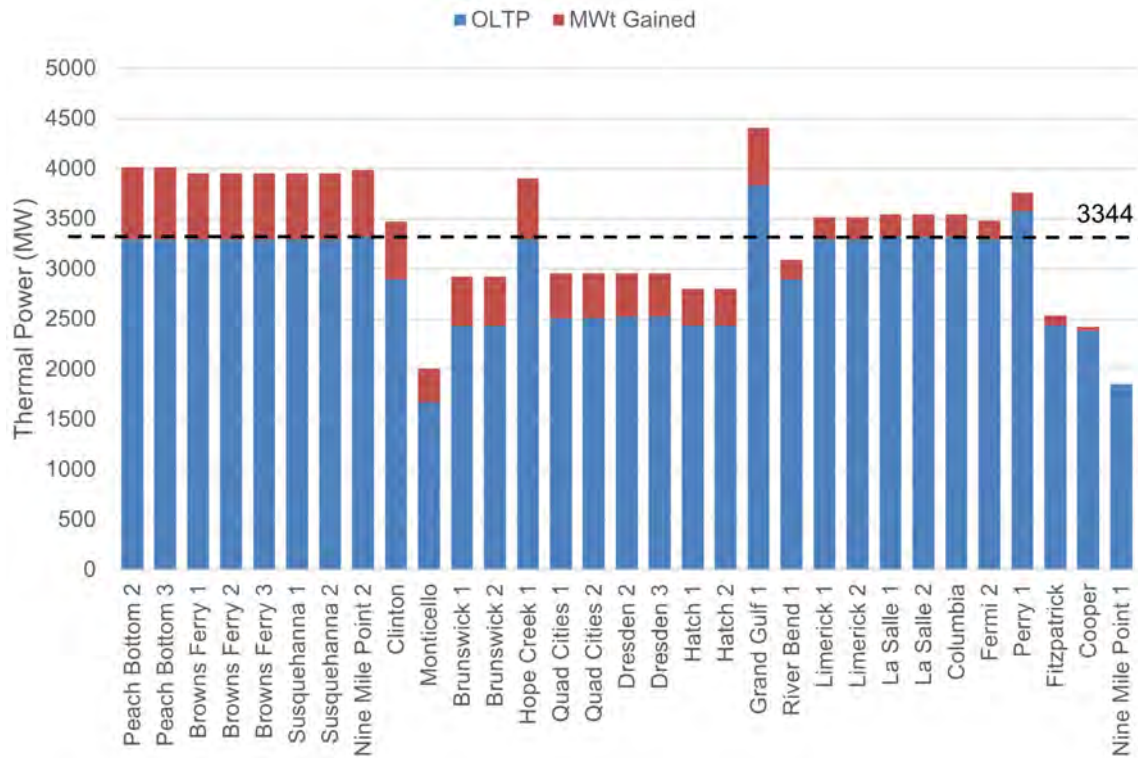

Figure 6. CLTP for operational BWRs in the United States (*dashed line indicates average CLTP*).

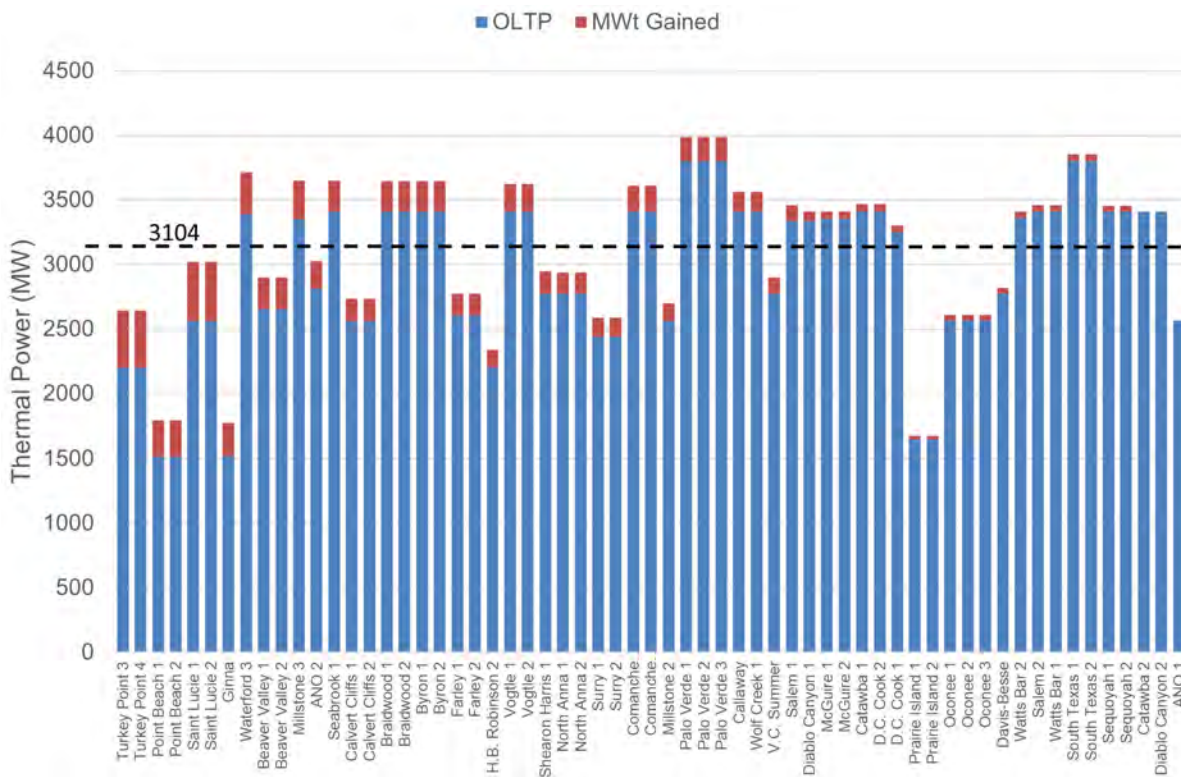

Figure 7. CLTP for operational PWRs in the United States (*dashed line indicates average*).

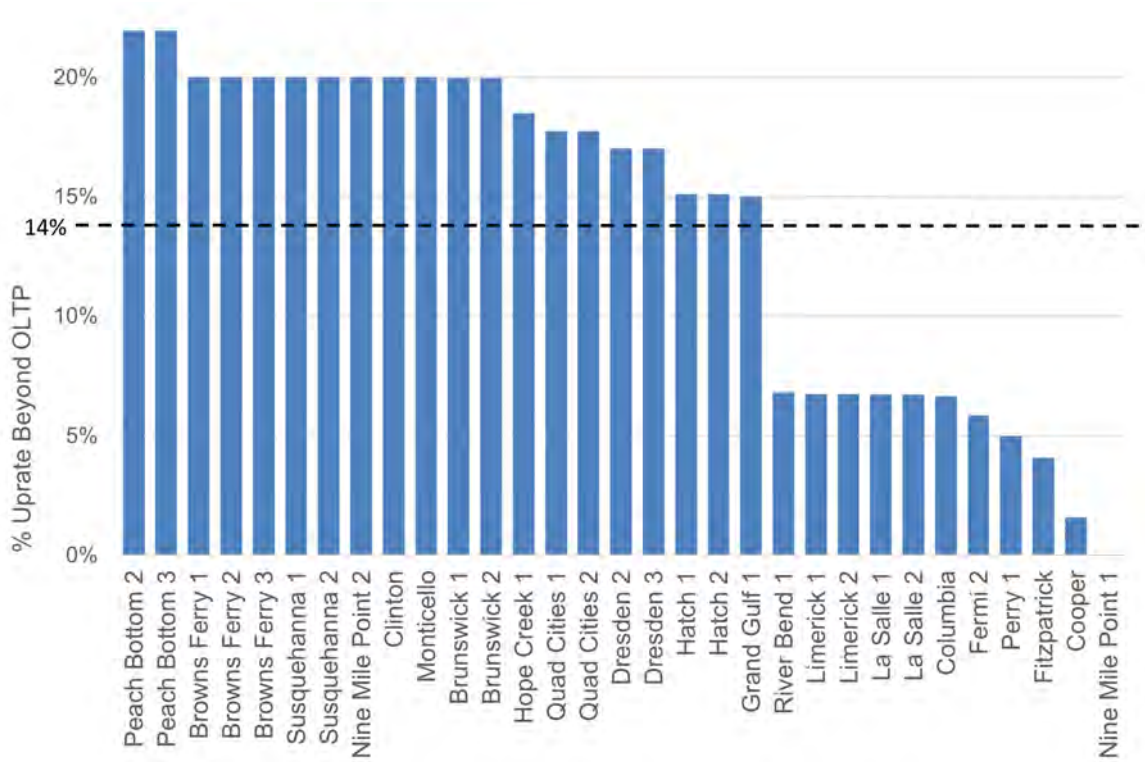

Figure 8. Total percent uprate for operational BWRs in the United States beyond OLTP (dashed line indicates average).

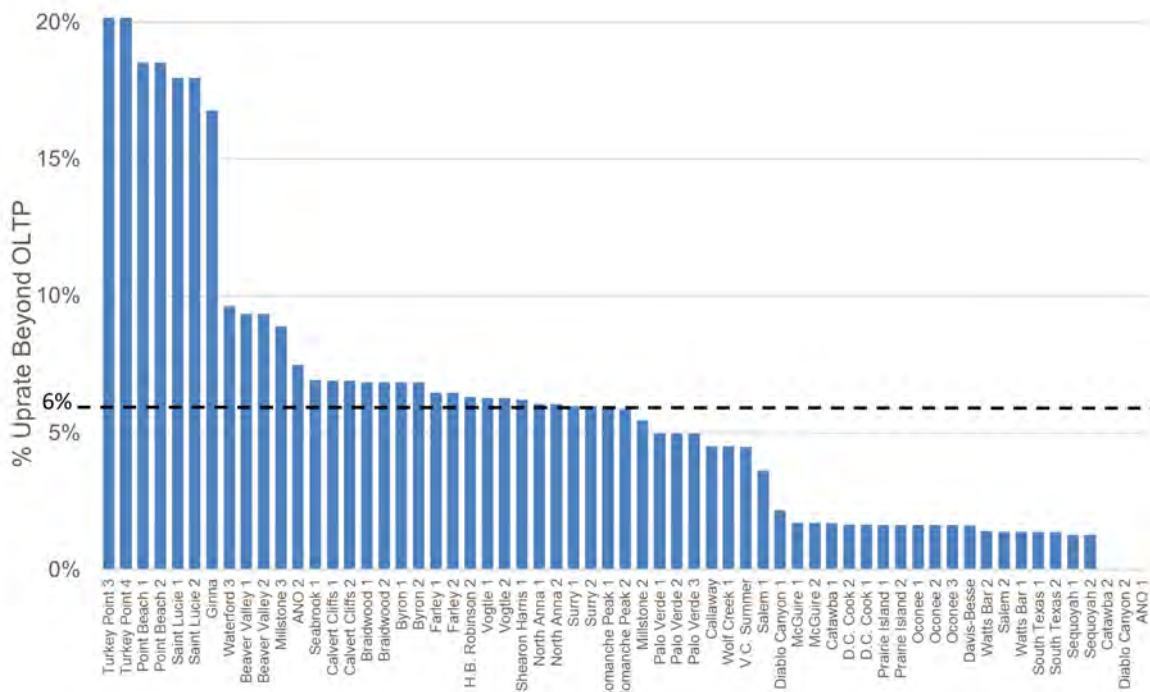

Figure 9. Total percent uprate for operational PWRs in the United States beyond OLTP (dashed line indicates average).

Another way of viewing this dataset is to examine uprates for plants in regulated vs. merchant markets. Of the 93 currently operating reactors in the United States, 39 reactors operate in merchant markets, while 54 stations operate under cost-of-service regulation. Utilities in regulated regions operate as a natural monopoly in their service areas, which means that customers only have the option to buy power from them. State regulators in these areas oversee how the electric utilities set electricity prices to ensure that rates remain reasonable for customers. Retail electricity prices in regulated markets are set in such a way that the utility is able to recover its operating and investment costs alongside a fair rate of return on those investments. State regulators are often involved in the utilities' long-term planning process and require the utilities to justify long-term investments.

In merchant markets, customers have the option of selecting an electric supplier, rather than being required to purchase electricity from their local utility. This strategy introduces retail competition. In this case, the investment risk falls upon the electricity supplier, rather than the customer, unlike regulated markets.

Figure 10 and Figure 11 show the percent uprate beyond OLTP for stations in merchant and regulated markets, respectively. The average percent uprate for stations in merchant markets is approximately 10%, compared to an average percent uprate of approximately 7% for stations in regulated markets. Based on Figure 10 and Figure 11, there does not appear to be any significant correlation between uprates in regulated vs. merchant markets as both provide ample opportunity for future power uprates even considering historical industry uprate limits.

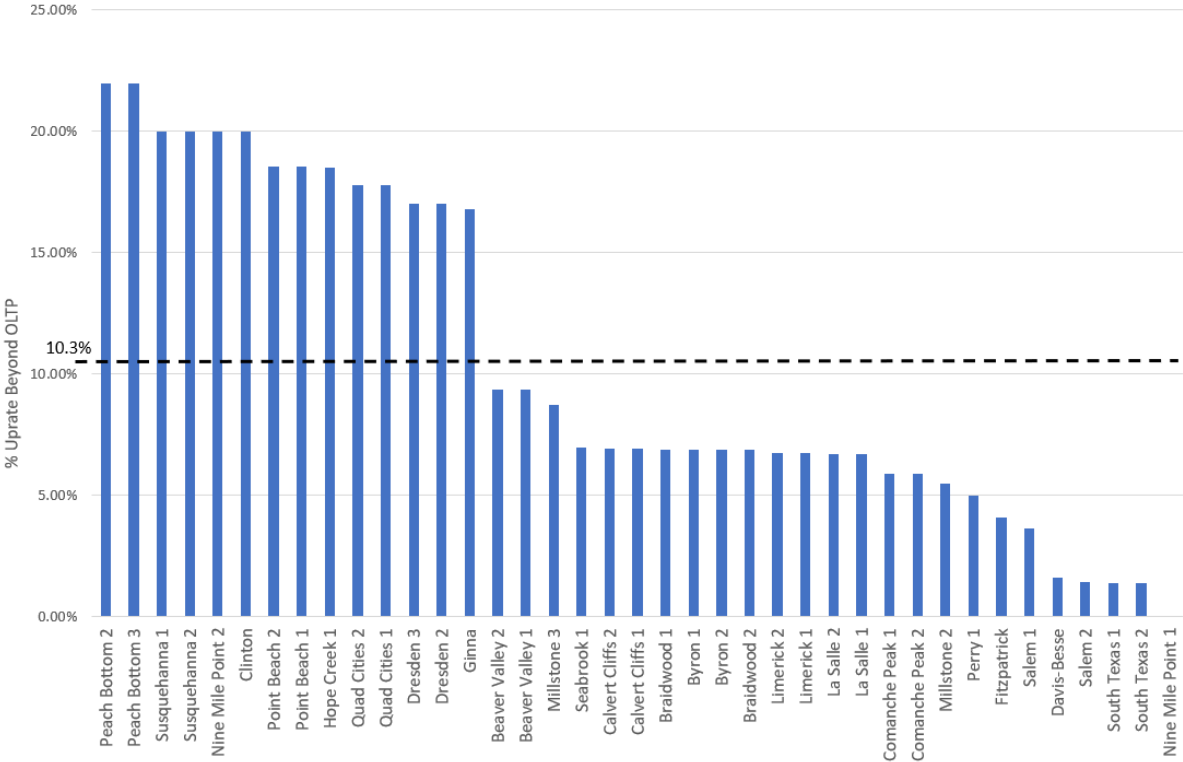

Figure 10. Total percent uprate for plants in merchant markets (dashed line represents average).

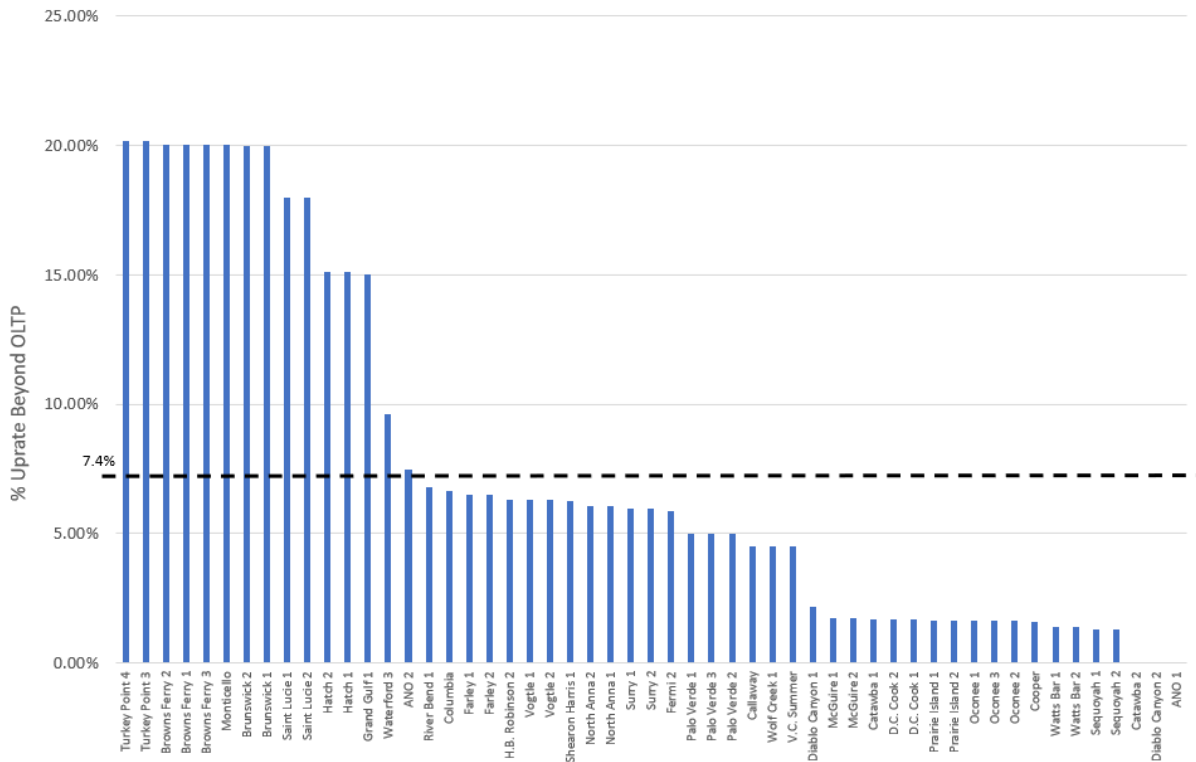

Figure 11. Total percent uprate for plants in regulated markets (*dashed line represents average*).

3.2.3 Power Uprate Market Opportunity

Based on the findings discussed above, there appears to be a significant amount of “untapped” power available to be claimed by uprating existing U.S. NPPs. That is, there is ample opportunity to uprate the existing domestic fleet independent of financial analyses. An attempt to quantify this opportunity in a reasonable manner is provided below for context, that is, these numbers are independent of technical analyses and are provided only as an example.

For BWRs, it is assumed that each plant that is currently operating at less than 120% OLTP performed an uprate to reach 120% OLTP. This is reasonable as there is already a generic approach in place that has been approved by the NRC to uprate BWRs up to 120% OLTP. This represents approximately 5,522 MWt of untapped power from the currently operating BWR fleet. It is important to note that, while 120% OLTP is the historical uprate value that BWRs have been able to achieve, stations could explore pursuing higher levels of uprate, although this would require a willingness to be the “first of a kind.” Figure 12 groups BWR uprate percentages by NSSS design type.

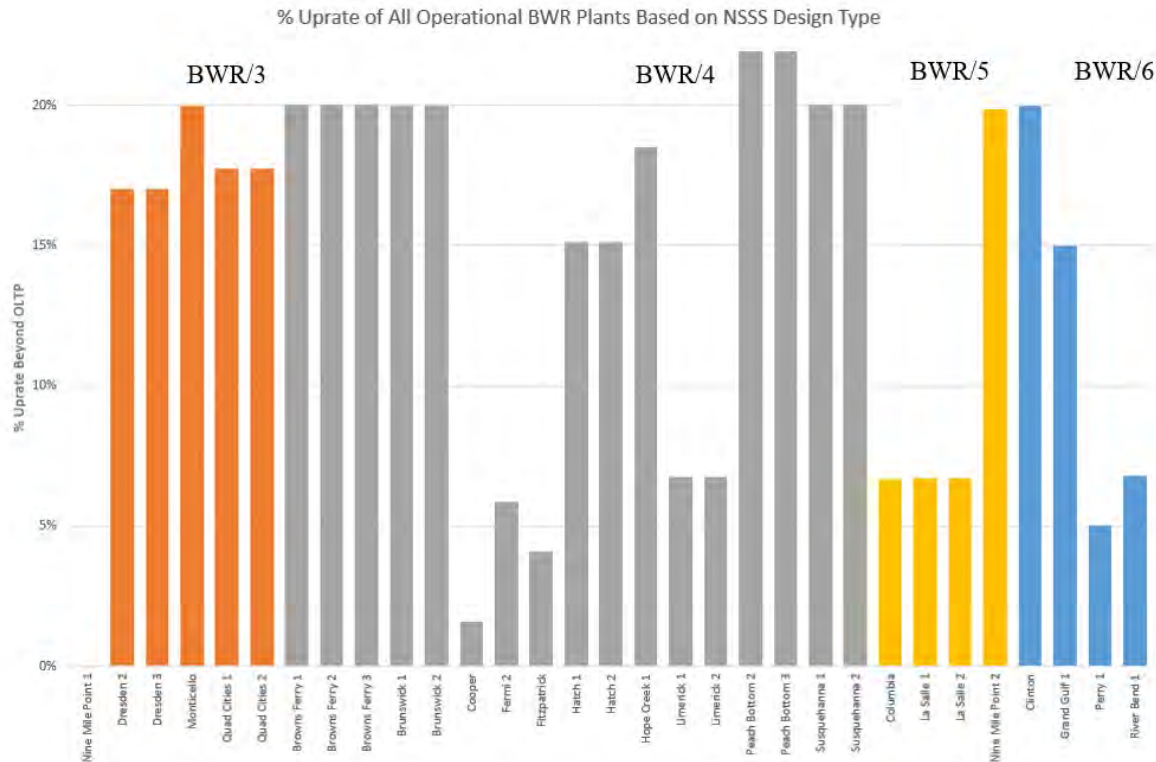

Figure 12. Percentage uprate in BWR plants based on NSSS design type.

For PWRs, it is assumed that each station reaches the maximum uprate percentage that has been achieved by a station with the same NSSS design. For example, Westinghouse four loop plants would be assumed to reach an uprate percentage of 109% OLTP, which is the historical maximum uprate percentage among Westinghouse four loop plants (Millstone Unit 3). It is noted that this approach is not perfect as units within the same NSSS design may have different steam generator vendors and types. However, this approach is only used in the context of providing a reasonable way to quantify the amount of untapped power available for PWRs. The results of using this approach are summarized in Table 2 with the total amount of untapped power that is available by uprating the existing PWR fleet as 10,931 MWt. Figure 13 groups PWR uprate percentages based on NSSS design type.

Table 2. Estimate of untapped power from the U.S. PWR fleet.

NSSS Design	Historical Maximum Uprate Percentage	Available Power Through Uprate (estimate) ¹
Westinghouse 4LP	9% (Millstone 3)	4,948 MWt
Westinghouse 3LP	20% (Turkey Point Units 3 and 4)	3,892 MWt
Westinghouse 2LP	18.5% (Point Beach 1 and 2)	585 MWt
CE-2L	18% (Saint Lucie 1 and 2)	1,464 MWt
CE80-2L	5% (Palo Verde 1, 2, and 3)	— ²
B&W LLP	1.6% (Oconee 1, 2, and 3)	42 MWt
B&W RLP	2% (Davis Besse)	— ²
Total Available Power		10,931 MWt

¹ Estimate is based on each unit of a particular NSSS type achieving the historical maximum uprate percentage for that NSSS type.
² All stations are already at the maximum historical uprate percentage.

% Uprate of All Operational PWR Plants Based on NSSS Design Type

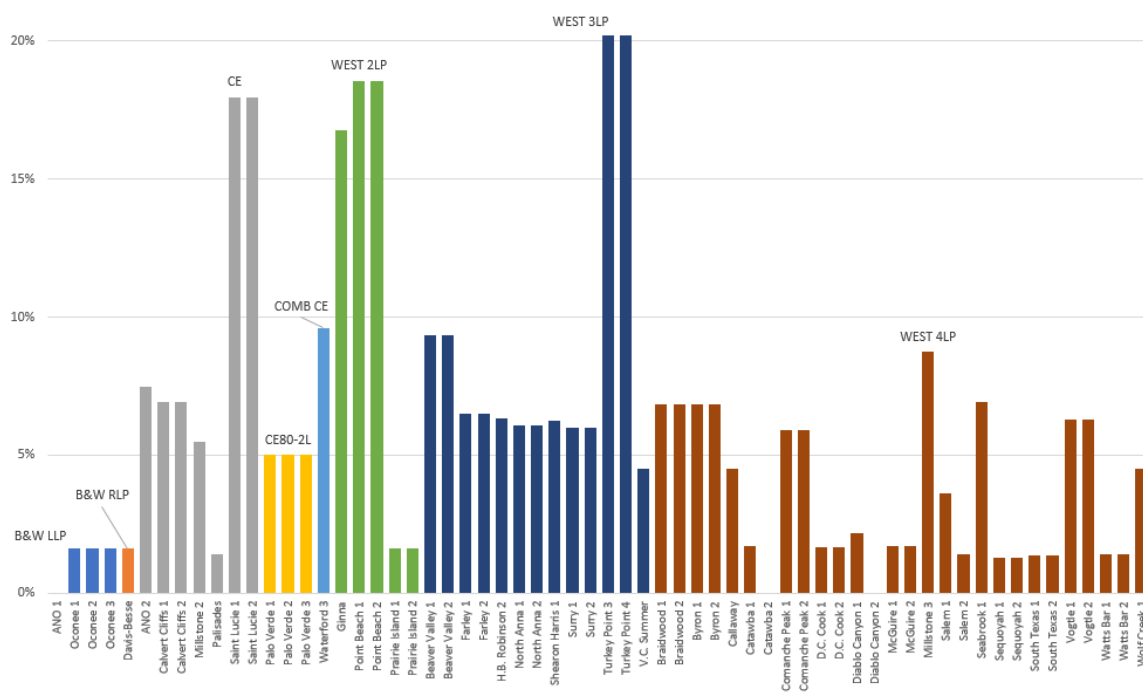

Figure 13. Percent uprate in PWR plants based on NSSS design type.

3.3 Hydrogen Market Overview

3.3.1 Introduction

There is growing interest in the production and use of low-carbon hydrogen as an alternative energy carrier to displace fossil fuels for applications that cannot be easily electrified or decarbonized and to provide a cost-effective approach for bulk long-term energy storage. Releasing the chemical energy from hydrogen in a fuel cell or via direct combustion does not generate carbon emissions, resulting in only water as a byproduct. However, 99% of hydrogen produced in the United States today is from steam methane reformation, which results in 8–12 kg of carbon dioxide emitted for each kg of hydrogen produced, which negates the zero-carbon benefit [12][13]. Low-carbon hydrogen, including hydrogen generated using energy from nuclear plants, can be used to replace this carbon-intensive hydrogen. In the United States, the push for increased low-carbon hydrogen production, utilization, and infrastructure has been accelerated by DOE’s “1 1 1” plan (i.e., Hydrogen Shot Initiative), which has a goal to reduce the price of low-carbon hydrogen by 80% to \$1 per kilogram over the next decade [14].

To help achieve these goals, the IRA included provisions with significant hydrogen PTCs, as discussed in Section 3.1. This legislation incentivizes the nuclear power plant (NPP) owner or operators to choose to produce hydrogen along with or instead of electricity. While this represents a fundamental shift in the operating and business models of a nuclear plant, this also presents an opportunity for utilities to diversify revenue streams and enter a market that is projected to significantly grow.

3.3.2 Incentive for Generating Hydrogen with a Nuclear Plant

Historically, NPPs have operated as base-loaded units. Operating as base-loaded units with constant power output at or near maximum capacity has typically been the most economically efficient mode of operation. However, changing market environments resulting from increased variable generation, low electrical load growth, and recent low natural gas prices have introduced challenges for nuclear plants. As a result, the nuclear industry is increasingly considering alternative modes of operation. These include operating the plant flexibly to

match power output with grid demand as well as diverting some electrical and thermal energy from the NPP for alternate functions. The approach of using a portion of the energy output for purposes other than delivering electricity to the grid could provide a second revenue stream while also maintaining a resilient and reliable supply of electricity to the grid. Potential alternate functions include hydrogen production from water-splitting electrolysis with nuclear energy (electricity and steam), industrial process heat, and desalination. Hydrogen production is of particular interest due to the emerging hydrogen economy and significant subsidization from the federal government (i.e., the IRA hydrogen tax credit).

3.3.3 Current Hydrogen Production Industry Status

At present, there are four broad methods to produce hydrogen. The following briefly explains each method and specific processes that fit within each:

- Thermochemical processes where heat and chemical reactions are used to extract hydrogen from different materials, including steam methane reforming (SMR), autothermal reforming, coal gasification, biomass gasification, biomass-derived liquid reforming, and solar thermochemical hydrogen.
- Electrolytic processes where electrolyzers use electricity to split hydrogen and oxygen from water at either high temperatures (high-temperature electrolysis [HTE]^b) or low temperatures (low-temperature electrolysis [LTE]^c).
- Direct solar water-splitting processes where hydrogen and oxygen are separated from water using solar power, including photoelectrochemical and photobiological processes.
- Biological processes where microorganisms produce hydrogen, including microbial biomass conversion and photobiological processes.

While SMR produces the vast majority of all hydrogen in the United States, the most prominent method of low-carbon hydrogen production is electrolysis. Energy from a nuclear plant can be used to generate hydrogen with either low-temperature electrolysis LTE, typically operating with temperatures below 100°C or HTE, typically operating with temperatures in the range of 700-800°C. The efficiency of HTE is typically greater than for LTE, as hydrogen cogeneration requires less electrical energy input at higher temperatures [15]. If HTE is used and the nuclear plants provides both steam and electricity directly, nuclear plant steam cycle modifications would be needed for steam takeoff and return to supply thermal energy to the hydrogen production facility. Modeling discussed in Section 5.3 considers both LTE and HTE applications.

Several pilot projects are under development in the United States to demonstrate a proof of concept of the technology integration for hydrogen cogeneration at a small scale with an existing NPP [16][17][18]. These pilot projects are summarized along with the type of electrolysis in Table 3. Lessons learned from these pilot projects will inform nuclear plant owners and operators as they consider implementing hydrogen cogeneration.

Table 3. Summary of current U.S. nuclear plant hydrogen pilots.

Plant (utility)	Electrolysis Type	Production Level
Davis Besse Nuclear Power Station (Energy Harbor)	LTE	~1 MW
Prairie Island Nuclear Generating Plant (Xcel Energy)	HTE	0.5 MW
Palo Verde Nuclear Generating Station (APS)	LTE	~20 MW—co-located with natural gas plant to use as fuel for gas turbines
Nine Mile Point Nuclear Station (Constellation)	LTE	~1.5 MW—this project began generating hydrogen in March 2023

^b HTE uses steam and electricity.

^c LTE uses electricity only.

3.3.4 Hydrogen Market Opportunity

Hydrogen is predominately used for industrial processes, such as petroleum refining, ammonia production, and methanol production, which have grown and resulted in increased demand for hydrogen. Figure 14 shows the breakout of demand between these demand sources for the U.S. sector in 2020 [19]. The demand for refining, ammonia, and methanol constitutes 95% of hydrogen consumption.

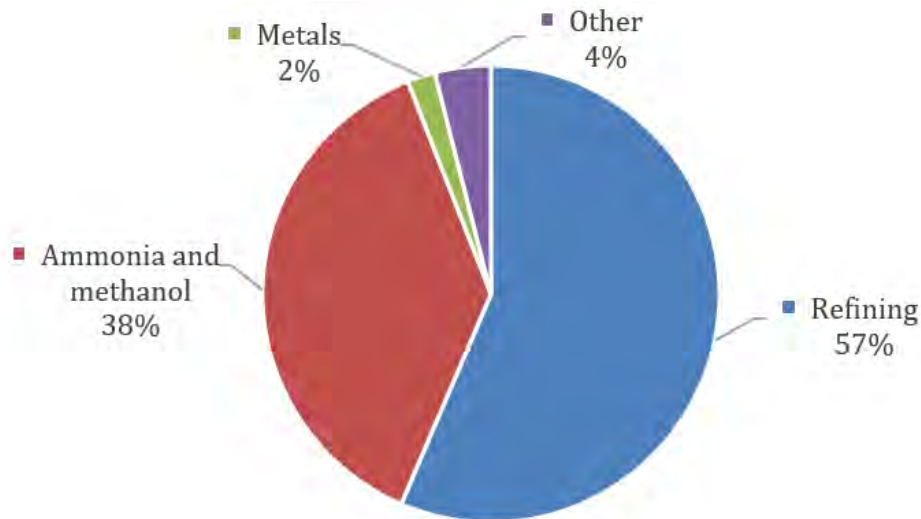

Figure 14. Hydrogen consumption breakdown in the United States in 2020, by sector.

Demand for hydrogen has seen steady growth in last two decades. Between 2000 and 2018, global demand for pure hydrogen grew by about 40% [20]. Hydrogen demand in the United States has also grown in recent years. As of 2021, annual hydrogen consumption in the United States was approximately 12 million metric tons (MMT), an 8% increase relative to 2020 [21]. There is also projected future demand for hydrogen in other applications, such as steel production, metals refining, biofuels production, synthetic hydrocarbon production, and transportation fuel cell electric vehicles (FCEVs) for light- and heavy-duty applications. Hydrogen can be used as fuel for turbines (potentially by blending with natural gas) or to generate power in a fuel cell. There are several additional future applications of hydrogen as an electricity source, which include emergency backup power (e.g., for telecommunications applications), prime power for critical loads (e.g., data centers, defense communications facilities, hospitals, and prisons), and peak power production [21][22].

The creation of hydrogen subsidies via the IRA has accelerated the pace at which future demand for clean hydrogen will materialize in two ways: by incentivizing existing and potential producers to invest more money into production and by further reducing the potential price at which clean hydrogen can be sold. Projections for total future demand vary depending on how low the price of clean hydrogen becomes. The National Renewable Energy Laboratory (NREL) published an extensive report that investigated this question and produced supply and demand curves for multiple industries with potential to be disrupted by clean, low-cost, hydrogen [22]. The upper bound of hydrogen demand by 2050 was found to be 106 MMT annually, 960% more than the current demand. The report also breaks out demand into the nine industries and presents threshold prices for each industry (i.e., the maximum price an industry is willing to pay before it selects an alternative). To reach such significant levels of demand would require multiple industries to begin using hydrogen that, at present, use little to none. This point is illustrated in Figure 15 where industry-specific demand projections from NREL's report are shown by industry.

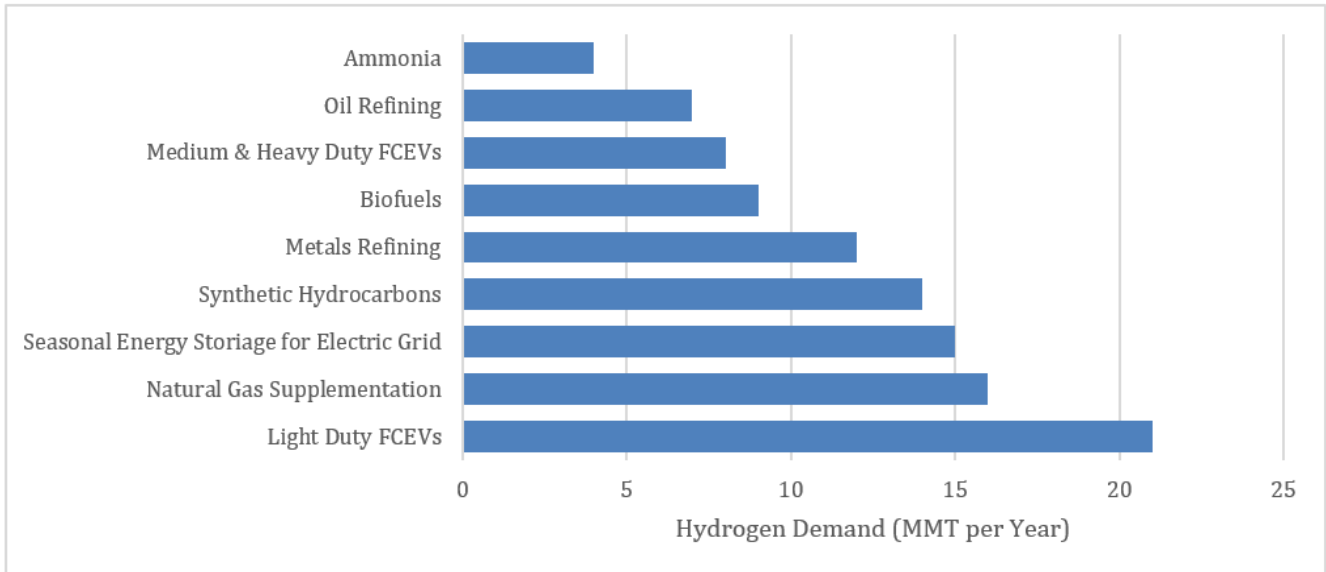

Figure 15. Potential U.S. clean hydrogen consumption by sector in 2050.

It should be noted that, for said levels of demand to be realized, industries would require the price of clean hydrogen to drop enough to displace current solutions. For example, the same NREL report estimates that, for the metals refining industry to begin using hydrogen, the price would need to be at or below \$0.80/kg. For light- to heavy-duty FCEVs, the price would need to be at or below \$2.20/kg [22]. Table 4 maps these price projections from NREL’s report to the threshold price^d (recall this is defined as the maximum price an industry is willing to pay before it selects an alternative) for each industry [22]. Note that, by summing all the demand for each industry, the total is 106 MMT annually. Thus, for hydrogen demand to reach this level, it would be necessary for the lowest threshold price in Table 4 to be met. In this instance, that would require hydrogen to be sold at \$0.00. However, even with subsidization this could prove difficult for producers to justify without hurting profitability targets. To further illustrate the relationship between price and demand, a variation of a demand curve can be created by mapping total demand with change in threshold price from Table 4 [22]. This is done in Figure 16 with current hydrogen demand overlaid for context.

Table 4. Projected industry-specific demand by 2050 and required threshold prices.

Industry	Clean Hydrogen Demand Potential by 2050 (MMT/year)	Threshold Price (\$/kg)
Ammonia	4	\$2.00
Oil Refining	7	\$3.00
Medium- and Heavy-Duty FCEVs	8	\$2.20
Biofuels	9	\$3.00
Metals Refining	12	\$0.80
Synthetic Hydrocarbons	14	\$0.00
Seasonal Energy Storage for Electric Grid	15	\$0.26

^d It should be noted that the threshold price includes both the cost of production as well as the cost of hydrogen compression and transportation. Depending on the compression and transportation mode used, these costs could become relatively significant.

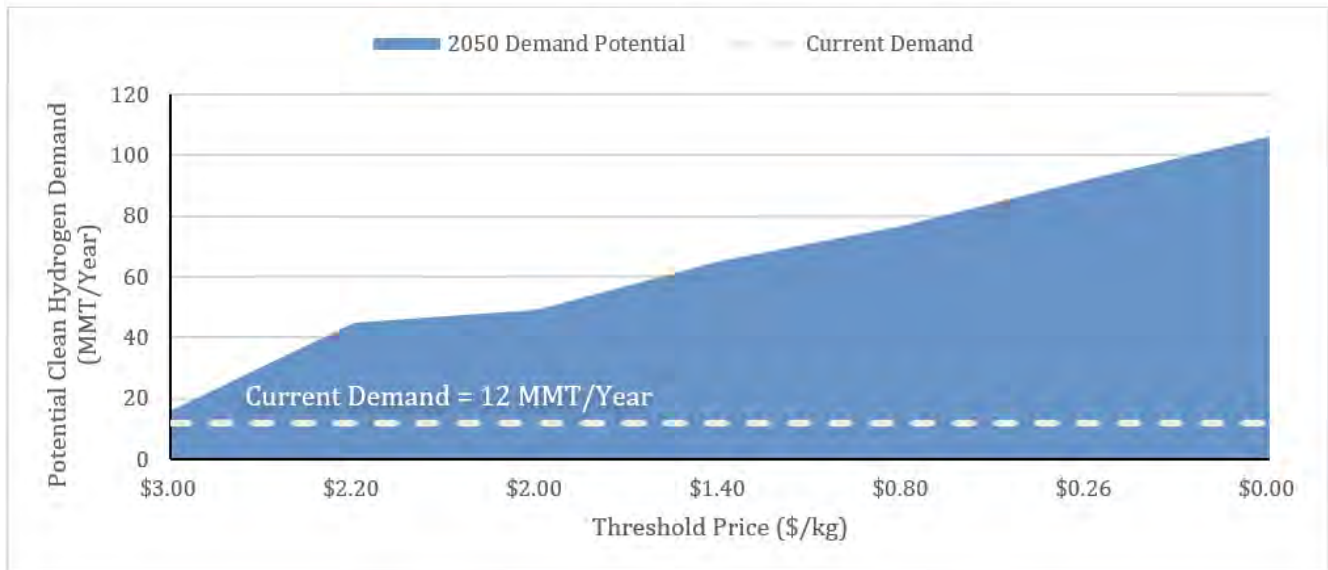

Figure 16. Clean hydrogen 2050 demand curve.

For suppliers, this demand-to-price mapping could be thought of as the required price targets for future demand growth. In practice, actual buy-in by industries will be a function of a myriad of factors, including technological capability, pressure to meet specific climate change targets, and impacts to a firm’s profit margins. Regardless, by combining the insights from Figure 15, Table 4, and Figure 16, the picture of a potential hydrogen driven economy becomes clearer. Clean hydrogen is poised to play a vital role in the decarbonization of multiple industries, and the producers needed to meet the demands of the future will need to begin building out capacity now.

While the overall outlook for the hydrogen market is favorable, the opportunity for a given NPP to sell hydrogen will need to be determined based on an assessment of the hydrogen market available to that specific plant. The owner or operator contemplating implementing hydrogen production will need to determine prospective customers, scale of operations, and sale price. To support utilities with developing the business case for hydrogen at nuclear plants, INL developed a report in 2021 that identified the scale, location, and accessibility of non-electricity markets to existing facilities. The report assessed the current and prospective future market size for various non-electricity products, including hydrogen [23]. This report and similar market analyses may be used by owners or operators as input for these assessments. Generally speaking, this research suggests that existing hydrogen demand is clustered in the Texas, Louisiana, and California regions.

Three major challenges that may impact the hydrogen market for existing nuclear plants include hydrogen distribution and storage, electrolyzer manufacturing capacity, and high cost to produce hydrogen via electrolysis relative to current methods. Regarding distribution, it is challenging to transport and store hydrogen due to its low energy density (by volume) and a current lack of widespread hydrogen transmission infrastructure (e.g., pipelines). Due to these challenges, a regional customer base for hydrogen produced by a nuclear plant may be needed. Hydrogen could be sold to consumers in a hydrogen hub, which is a group of co-located hydrogen generators, storage facilities, transportation infrastructure, and consumers. These hydrogen hubs will help address the challenges of transportation and storage. The Bipartisan Infrastructure Law provides \$8 billion to establish six to 10 regional clean hydrogen hubs [24]. The hydrogen hub funding is still in the application phase; DOE has provided preliminary feedback, including encouragement to a portion of the 79 applicants [24][25]. This DOE initiative to support hydrogen hubs includes provisions for the use of nuclear power. Specifically, one or two of the six to 10 hubs are slated to generate hydrogen using nuclear power.

The second potential challenge that could impact the hydrogen market outlook is the expected rapid growth in demand for electrolyzers. If global manufacturing capacity does not increase as rapidly as demand for electrolyzers, there could be impacts to nuclear plant owners or operators implementing hydrogen cogeneration, such as long lead times and high capital costs for electrolyzers. However, there is a positive outlook moving forward as equipment vendors recognize the need for increased capacity. Numerous companies have announced plans to develop manufacturing capabilities. Global manufacturing capacity was estimated to be 8 GW/year in 2021, more than double the capacity in 2020. This growth is projected to continue in the future [26]. The estimated compounded annual growth for the global electrolyzer market is estimated at 24.8% between 2020 and 2030 [27].

Finally, the relatively high cost to produce hydrogen with electrolysis is also a challenge to implementing hydrogen cogeneration with an existing NPP. The most prominent method for producing hydrogen is currently SMR with natural gas, which has significantly lower costs than current electrolysis methods [22]. The costs associated with hydrogen production via electrolysis are on a downward trend and are expected to continue to decrease. The apparent gap in cost of production between SMR hydrogen and clean hydrogen is a major reason why subsidization was considered necessary. The IRA Section 45V Clean Hydrogen Production Credit is intended to allow NPP owners or operators to recover the production costs while selling hydrogen for a price that is competitive with SMR. The needed cost reductions to make clean hydrogen technology competitive are also likely to come from increased interest from the private sector. According to public records, the number of annual private investment deals (venture capital and private equity deals) has more than tripled since 2014. In 2022 alone, private investments (including both venture capital and private equity) in hydrogen related companies totaled more than \$4.7 billion, funding 192 startups [28].

3.3.5 Conclusion

The low-carbon hydrogen market is still emerging. Currently the outlook is favorable, and there is expected to be a market for nuclear plants to sell hydrogen. There are challenges with implementing hydrogen cogeneration, including integration of a hydrogen cogeneration system with a nuclear plant, high electrolysis-based hydrogen production costs compared to current methods, hydrogen transmission and storage, and manufacturing capacity of electrolyzers, but efforts are underway by industry, with government support, to overcome these challenges.

Recall that the modeling done in this report assumes that the hydrogen produced by an NPP is consumed at the plot edge of said plant. This means the analysis assumes the produced hydrogen does not require significant storage, compression, or transportation costs. An example of such a scenario could be one where an ammonia plant is built adjacent to an NPP and the produced hydrogen is directly fed into the ammonia production plant. If storage, compression, and transportation costs were to be considered, the economics discussed herein would change. Ultimately, an NPP operator aiming to produce hydrogen in the future should first seek to answer two key questions. First, what would be the plant's levelized cost of hydrogen and sale prices with and without subsidies? Second, does existing or future demand exist near the plant's location, and can it sell hydrogen at or below the projected threshold price of that industry? If the hydrogen can be produced at a competitive price where local demand exists, there may be a very strong case for the NPP to add hydrogen to its product portfolio.

4. POWER UPRATE SYSTEM, STRUCTURE, AND COMPONENT ASSESSMENT

4.1 System, Structure, and Components Impacted by Power Uprate

NPPs were constructed with margin included in the design and operational limits of every system, structure, and component. Plants use margin in design space, as well as operational limits, to ensure compliance with plant and regulatory requirements. Several different types of margins are employed in the design and operation of NPPs, namely operating, design, and analytical margins.

This inherent plant margin has allowed utilities to implement several different strategies to achieve significant power uprates. For BWRs, GE established an NRC-approved process for extending thermal power to

as high as 120% OLTP. The initial version of these guidelines, and subsequent safety evaluations, assumed that the maximum operating reactor pressure would also be increased. These guidelines were applied to several stations. Subsequently, GE developed an alternative approach to power uprate that maintains the current plant maximum operating reactor pressure (i.e., constant pressure power uprate). By performing the power uprate with no pressure increase, there is a smaller effect on the plant safety analyses and system performance. Constant pressure power uprates have also been implemented at several plants and will most likely be pursued for future BWR power uprate applications. The constant pressure power uprate approach for BWRs increases the core flow along the maximum extended load line limit analysis rod line in a range of core flow from just under the rated core flow to the maximum licensed core flow. Note that this process minimizes significant modifications for NSSS components but typically does require significant modifications to balance-of-plant components. For PWR units, no change to operating pressurizer pressure is the most common approach to power uprate; however, there is no generic NRC-approved uprate process for PWRs (i.e., PWR power uprates are extremely site specific).

Regardless of the strategy employed to increase thermal power, there are a number of general plant impacts due to power uprate, including:

- The steam flow from the BWR pressure vessels or the PWR steam generators will increase, resulting in increased pressure drops and greater dynamic loads on various systems. For example, condensate and feedwater flow will experience a corresponding increase that may pose a risk of increased vibration or degradation of certain components.
- The power plant environment will be subject to larger amounts of waste heat, which could challenge the cooling water systems.
- The mean value of power density in the core will increase, which could require the utility to invest in improved fuel designs that have larger margins to safety limits.
- Neutron irradiation in the core region will increase, potentially changing requirements for monitoring programs. Downstream plant waste streams will contain higher concentrations of radiological materials, placing additional strain on radwaste processing systems.
- Plant decay heat will be increased, requiring additional capacity from safety systems. Energy releases into the primary containment will be greater in the event of an accident.

The extent of the modifications required to implement power uprate (and mitigate the impact on plant margin) is highly plant specific and depends on factors such as the desired power level, the capacity of currently installed equipment, and the margin that was included in the original plant design. Early power uprates were typically MURs or SPUs. As discussed previously, MURs typically do not require modifications other than more precise feedwater flow measurement devices while SPUs can often be achieved within existing plant margins by changing instrumentation setpoints. For some SPUs, plants have made modifications to turbine valves, early-stage HP turbine buckets, feedwater pumps, or the ultimate heat sink in order to accommodate increases in flow.

For EPU, plants are often required to replace major equipment that would otherwise be a pinch point limiting the increase in power. Table 5 provides a listing of common components and systems affected by power uprates along with details on the specific aspects that are challenged. Some of the most significant component replacements from this list include:

- HP turbines to increase flow passing capability
- Generator replacements, rewinds, or cooling upgrades to accommodate the increase in power generation
- Internals of the moisture separators and moisture separator reheaters (MSRs) to provide adequate moisture separation at the increased steam flows
- Feedwater and condensate pumps to provide increased flow
- Main transformers to be compatible with the increased electrical output

- Upgrades to the circulating water system to reject additional energy due to power uprate (e.g., upgrades to natural draft cooling towers or the addition of supplemental mechanical draft cooling towers).

Table 5. SSCs impacted by power uprate.

SSC	Power Uprate Impact
Condensate Filter Demineralizers	The condensate filter demineralizers will be required to handle increased flow rates and temperatures as a result of the power uprate. These conditions could challenge the effectiveness of the filtration media. Power uprate conditions could increase the required frequency of backwash or resin regeneration activities. It is common for utilities to add new demineralizer vessels or supplement existing systems with new, skid-based systems.
Cooling Water Systems (e.g., circulating, service water)	An evaluation of the ultimate heat sink is required to confirm an adequate heat removal capability for the uprate conditions during all seasons and for all design basis events. Utilities may be required to perform upgrades to cooling towers or request a revision of the water permit to increase discharge flow or temperature.
Pumps and Prime Movers	Pumps in multiple systems will need to be evaluated to ensure capacity is adequate for the increased flow rates (e.g., sufficient net positive suction head). Required upgrades could include impeller upgrades, motor upgrades, or full replacements. Common pumps that are upgraded as part of power uprate include: <ul style="list-style-type: none"> • Condensate pumps and condensate booster pumps • Feedwater pumps • Auxiliary feedwater pumps • Heater drain pumps.
Feedwater Heaters (FWHs) and Vents and Drains	Implementation of power uprate may require larger FWHs with nozzles, drain coolers, and other equipment sized to accommodate the higher feedwater flow rates, extraction steam flow rates, and drain flow rates.
Main Condenser	The thermal performance of the condenser may be challenged by the increased steam flow. The larger load on the condenser will also increase condenser backpressure and reduce margin to various setpoints (e.g., low pressure [LP] vacuum). Increases in steam flow velocity could cause flow-induced vibrations or increased erosion on the shell, tubes, or supports.
Main Steam System	The main steam piping and its supports require evaluation for vibration and erosion issues due to the increased steam flow rate.
Main Turbine	The main turbine requires evaluation to ensure adequate flow passing capability for increased steam flow. Almost universally, a complete retrofit of the HP turbine flow path is required for EPU. While less common, LP turbines may also require modification. Associated piping expansion joints (or bellows) may also require replacement to accommodate higher design temperatures and pressures (e.g., extraction steam, crossover or crossover piping).
Moisture Separator and MSR	Power uprates result in increased steam flow and drain flow in the MSRs, which may necessitate upgrades or replacements. As the HP turbine steam flow is increased with EPU, industry experience has shown that the cross around relief valves often require replacement to increase relieving capacity.

Table 5. (continued).

SSC	Power Uprate Impact
Fuel	Fuel performance characteristics are assessed as part of the fuel reload analysis. The core power distribution is often modified to allow for an increase in the overall core power while limiting the absolute power in any individual fuel bundle. Utilities may elect to use new fuel designs, enrichments, or higher batch fractions to provide additional operating flexibility and maintain cycle length.
Nuclear Instrumentation	Nuclear instrumentation will need to be recalibrated to read 100% at the new licensed power level. The instrument ranges may also need to be adjusted such that the overlap between source, intermediate, and power range remains adequate. The increase in power level will increase flux at various neutron detectors (especially in-core detectors). These detectors will require replacement more frequently.
Heating ventilation and air conditioning Systems	Power uprate will result in increased heat loads in spaces throughout the plant, particularly in rooms and air spaces where main steam lines traverse as well as in rooms with large motors. Heating ventilation and air conditioning systems will need to be evaluated for potential changes to the post-accident heat load due to power uprate.
Steam Dryer and Separators (BWR)	Steam dryers have been significantly impacted at several BWRs following EPU implementation due to flow and acoustically induced vibration. These impacts result from increased main steam flow at EPU conditions and the potential increase in high cycle fatigue due to adverse flow effects. Material failure can result in loose parts generation that could damage safety-related equipment downstream of the steam dryers. The NRC has required licensees to demonstrate a 100% margin on the maximum alternating stress in the steam dryer components for projected EPU conditions. As a result, steam dryer replacement has become common for EPUs.
Steam Generator (PWR)	Steam generators are a common pinch point for PWR power uprates. Steam generators require evaluation for several critical parameters, including heat transfer capacity, moisture carryover, flow-induced vibrations at the increased flow rate, and water level stability. In the past, PWR stations typically elected to limit their percentage uprate to avoid the expense and risk of performing steam generator replacements.
Spent Fuel Pool and Storage	The spent fuel pool cooling system requires evaluation to determine its capability to remove the decay heat from the spent fuel post power uprate implementation. If a new fuel design is implemented, utilities may also be required to modify the spent fuel pool storage racks or spent fuel handling procedures. Depending on the results of the spent fuel criticality analyses, utilities may be required to install additional neutron absorbing inserts in the storage racks or implement new administrative controls to limit the placement of fuel to approved storage configurations.

Table 5. (continued).

SSC	Power Uprate Impact
Main Generator and Auxiliaries	The main generator requires evaluation to confirm that its megavolt-amperes (MVA) rating is sufficient for EPU conditions. In many cases, the main generator will require a stator and rotor rewind or full replacement for EPU. Other common modifications for power uprate include exciter replacements, hydrogen cooler replacements, current transformer replacements, and main generator protective relay replacements.
Isophase Bus Duct	The power uprate will result in more current traveling through the isophase bus, which could challenge the ampacity rating of the conductors. The increased current will also generate more heat, which could necessitate upgrades to the isophase bus duct cooling equipment.
Large Transformers	Stations may be required to increase the capacity of the main transformers to accommodate the higher main generator MVA output. Industry evidence suggests that full replacement of the main power transformers is the most common approach.
AC Distribution Systems and Grid Stability	Power uprate will increase the power flow from the station to the grid. Issues associated with the grid interface include local grid voltage regulation, avoidance of transmission system overloads, oscillatory behavior, and protection from fault currents. Modifications to breakers, disconnects, or sections of transmission line are common with EPU. Utilities may also be required to install new inductors or capacitor banks for reactive power requirements.

To supplement Table 5, a review was performed for publicly available sources (e.g., NRC submittals and responses) to ascertain significant plant modifications made by BWRs and PWRs over the last decade or so. The findings of this review are summarized in Table 6 [5][29][34] and Table 7 [35][37], which list significant modifications that were performed in support of EPU at several BWRs and PWRs, respectively.

Table 6. Survey of recent EPU experience for BWRs.

Parameter or Modification	Plant			
	Browns Ferry	Peach Bottom	Monticello	Grand Gulf
Thermal Power Increase	494 MWt (~14%)	437 MWt (~12%)	229 MWt (~13%)	510 MWt (~13%)
NRC Approval Date	August 2017	August 2014	December 2013	July 2012
Steam Dryer Modifications	- Replaced	- Replaced	- Replaced	- Replaced
Pump and Prime Mover Modifications	<ul style="list-style-type: none"> - All condensate and condensate booster pump impellers changed and larger motors installed - Reactor feedwater pumps replaced with higher capacity pumps - Reactor feedwater pump turbine enhancements - Re-rate of reactor recirculation pumps and motors 	<ul style="list-style-type: none"> - All condensate pump impellers changed and larger motors installed (six total) - Reactor feedwater pump turbines retrofitted 	<ul style="list-style-type: none"> - Condensate pump impellers enlarged and larger motors installed (replaced 4 KV motors with new 13.8 KV motors) - Reactor feedwater pumps replaced with larger pumps and motors (replaced 4 KV motors with new 13.8 KV motors) 	<ul style="list-style-type: none"> - Reactor feedwater pump turbines retrofitted
Main Turbine Modifications	<ul style="list-style-type: none"> - HP turbine rotors replaced 	<ul style="list-style-type: none"> - HP turbines replaced 	<ul style="list-style-type: none"> - HP turbine replaced with a new rotor and diaphragms - Replacement of several diaphragm sets and one row of buckets in each LP turbine 	<ul style="list-style-type: none"> - HP turbine replaced
Generator Modifications	<ul style="list-style-type: none"> - Generator stators rewind - Installation of self-excited excitation system 	<ul style="list-style-type: none"> - Generator rotor rewind (Unit 2) and new rotor installed (Unit 3) 	<ul style="list-style-type: none"> - Generator stator and rotor rewind - Generator exciter replaced 	<ul style="list-style-type: none"> - Generator stator and rotor refurbished
Condensate Filter Demineralizer Modifications	<ul style="list-style-type: none"> - Additional condensate filter demineralizer vessel installed on each unit 	<ul style="list-style-type: none"> - Four (two per unit) additional condensate filter demineralizer vessels installed 	<ul style="list-style-type: none"> - Replaced the existing condensate demineralizer vessels with new vessels and new controls installed 	<ul style="list-style-type: none"> - Replaced existing condensate filter demineralizers with new condensate full-flow filtration skid

Table 6. (continued).

Parameter or Modification	Plant			
	Browns Ferry	Peach Bottom	Monticello	Grand Gulf
FWH Modifications	<ul style="list-style-type: none"> - First, second, and third point FWHs re-rated - Internals modifications performed on several other FWHs 	<ul style="list-style-type: none"> - Five FWHs replaced 	<ul style="list-style-type: none"> - FWHs 13, 14, and 15 replaced - Re-rated 11 and 12 FWHs and replaced 11 and 12 external drain coolers 	<ul style="list-style-type: none"> - Second, third, and fourth point FWHs replaced (nine total)
MSR Cross Around Relief Valve Modifications	<ul style="list-style-type: none"> - Cross around relief valves modified 	<ul style="list-style-type: none"> - Setpoints for all 12 (six per unit) cross around relief valves adjusted (no physical modifications) 	<ul style="list-style-type: none"> - Cross around relief valves replaced along with discharge piping 	<ul style="list-style-type: none"> - Cross around relief valves replaced
Extraction Steam Expansion Joint Modifications	<ul style="list-style-type: none"> - Bellows 2, 3, 4, and 5 replaced with bellows accommodating higher design temperatures and pressures 	<ul style="list-style-type: none"> - N/A 	<ul style="list-style-type: none"> - Extraction steam expansion joints replaced 	<ul style="list-style-type: none"> - None
AC Distribution System Modifications	<ul style="list-style-type: none"> - None 	<ul style="list-style-type: none"> - None 	<ul style="list-style-type: none"> - New 13.8 KV bus added to supply new motors supporting EPU implementation 	<ul style="list-style-type: none"> - None
Modifications Required for Grid Stability	<ul style="list-style-type: none"> - N/A 	<ul style="list-style-type: none"> - None 	<ul style="list-style-type: none"> - Remote reactive capability added 	<ul style="list-style-type: none"> - Local transmission system upgraded and capacitor banks installed for reactive power requirements
Transformer Modifications	<ul style="list-style-type: none"> - Main power transformers replaced 	<ul style="list-style-type: none"> - Main power transformers replaced 	<ul style="list-style-type: none"> - Main power transformer replaced 	<ul style="list-style-type: none"> - Main power transformer replaced

Table 6. (continued).

Parameter or Modification	Plant			
	Browns Ferry	Peach Bottom	Monticello	Grand Gulf
Other Key Modifications	<ul style="list-style-type: none"> - Increased ventilation capacity for condensate and booster pump areas - Acoustic vibration suppressors installed on main steam line blind flanged branch lines 	<ul style="list-style-type: none"> - New spring safety valve installed for increased anticipated transient - Without SCRAM (ATWS) loads 	<ul style="list-style-type: none"> - Feedwater regulating valve replacement - Reactor feedwater pump discharge check valve replacement 	<ul style="list-style-type: none"> -New radial well - Staking and repairs to main condenser tubes - Increase ultimate heat sink inventory
NOTE: A response of N/A indicates that information was not available for a particular modification.				

Table 7. Survey of recent EPU experience for PWRs.

Parameter or Modification	Plant		
	Turkey Point (Units 3 and 4) ¹	Point Beach (Units 1 and 2)	St. Lucie (Unit 2) ²
Thermal Power Increase	344 MWt (~15%)	260 MWt (~17%)	320 MWt (~12%)
NRC Approval Date	May 2011	June 2012	September 2012
Main Turbine	- HP turbines replaced	- HP turbines replaced	- HP and LP turbines replaced
MSRs	- Replaced MSRs	- None	- Replaced MSRs
Main Generator	- Stator rewind, new rotor, new current transformers, new hydrogen coolers, new exciter air coolers	- Main generator rewind, modified hydrogen coolers, exciter cooler replacement, exciter upgrade	- Stator rewind, new rotor, new current transformers, new hydrogen coolers, new exciter air coolers
Isophase Bus Duct	- Main bus replaced with larger conductors and enclosures	- Isophase bus duct fan and cooler replacements	- Isophase bus duct cooling system upgrades
Main Transformers	- Cooling and tap changer modifications	- Main step-up transformers replaced	- Main transformers replaced
Main Condenser	- Tube bundles and water boxes replaced	- Additional tube staking	- None

Table 7. (continued).

Parameter or Modification	Plant		
	Turkey Point (Units 3 and 4) ¹	Point Beach (Units 1 and 2)	St. Lucie (Unit 2) ²
Pumps and Prime Movers	<ul style="list-style-type: none"> - Feedwater pump rotating assemblies replaced - Condensate pumps replaced - Modified auxiliary feedwater pumps 	<ul style="list-style-type: none"> - Condensate pump and motor replacements - Feedwater pump and motor replacements - New motor driven auxiliary feedwater pumps 	<ul style="list-style-type: none"> - Replaced condensate pumps - Replaced feedwater pumps - Replaced heater drain pumps
FWHs	<ul style="list-style-type: none"> - Replaced #5 and #6 FWHs - Modify FWH #5 drain line piping - Replace extraction steam piping from HP turbine to FWH #6 (Unit 3) 	<ul style="list-style-type: none"> - FWHs 1A/B–5A/B replaced 	<ul style="list-style-type: none"> - Replace #5 FWHs
Grid Stability	<ul style="list-style-type: none"> - Installation of new inductors and capacitors at the 240 kV switchyard 	<ul style="list-style-type: none"> - 345 kV AC transmission system upgrades (breaker protection improvements, line segment upgrades, installation of a switching station) 	<ul style="list-style-type: none"> - Increase in the rating of three St. Lucie–Midway transmission lines from 2380A to 2790A
Other Modifications	<ul style="list-style-type: none"> - Main steam isolation valves and main steam check valves replaced 	<ul style="list-style-type: none"> - Main steam isolation valve upgrades - Addition of main feedwater isolation valves 	<ul style="list-style-type: none"> - Replaced turbine cooling water heat exchangers
<p>NOTE: A response of N/A indicates that information was not available for a particular modification.</p> <p>^{1.} Turkey Point 3 and 4 power uprate includes a 1.7% measurement uncertainty recapture.</p> <p>^{2.} St. Lucie Unit 2 power uprate includes a 1.7% measurement uncertainty recapture.</p>			

4.2 Historical Power Uprate Financial Information

As discussed above, the costs associated with power uprate are highly plant specific and dependent on the historic capital investment already put into the site, plans for future investment, as well as existing plant margin. As such, it is not reasonable to establish a scale for estimated cost per unit power increase nor provide specific cost estimates for typical power uprate modifications. Instead, to provide context on power uprate costs, publicly available costs for historical power uprates are provided for context on potential uprate cost ranges. Three publicly available cost ranges for EPU's are provided in Table 8 [38][39][41].

It is noted that the costs in Table 8 are spread across a wide range. There are many factors that can result in wide ranges in costs even when utilities may have a similar scope of required plant modifications. Some of these important considerations include:

- Separation of life-cycle management and incremental power uprate costs. That is, plants may synergize projects which will occur for life-cycle management if modification is required for power uprate as well. As discussed in [39], it can be challenging for the stations to separate power uprate costs from existing life-cycle management costs (e.g., power uprate pulling life-cycle management projects forward in time to accommodate the increased power output).
- Many of the required modifications for power uprates are complex and require specialized design work and specialized labor to support installation.
- Modifications can occur in areas of the plant that are rarely accessed or require extensive interference removal (including radiologically controlled areas).
- Utilities that have performed power uprates in the past have been susceptible to equipment design complications, vendor performance issues, and underestimating the difficulty of completing installation work in the plant.

Table 8. Power uprate historical costs.

Plant	Uprate Amount	Capital Cost	Major Equipment Modifications
Station 1 (3 units)	494 MWt (~14%)	\$475M for three units (2017 dollars)	<ul style="list-style-type: none"> • Installed new steam dryer • Replaced HP turbine rotor • Modify the cross around relief valves to permit increased set pressure • Upgraded condensate pumps with new impellers and motors • Replaced condensate booster pumps and motors • Replaced the feedwater pumps • Enhanced feedwater pump turbine • Modified the internals of the moisture separators for EPU conditions • Re-rated FWH 1, 2, and 3 shells • Replaced level control instrumentation (FWHs 1, 2, and 3) • Installed a new condensate demineralizer on each unit • Rewind main generator stator • Replaced main power transformers
Station 2 (1 unit)	229 MWt (~13%)	\$665M (2013 dollars)	<ul style="list-style-type: none"> • Steam dryer replacement • Condensate pump impeller modifications, larger motors installed • Reactor feedwater pumps and motors replaced • HP turbine replaced, replacement of several diaphragm sets and one row of buckets in each LP turbine • Generator stator and rotor rewind • Generator exciter replaced • Condensate demineralizer vessels replaced and new controls installed • FWHs 13, 14, and 15 replaced • Cross around relief valves replaced along with discharge piping • New 13.8 KV bus added • Main power transformer replaced

Table 8. (continued).

Plant	Uprate Amount	Capital Cost	Major Equipment Modifications
Station 3 (1 unit)	510 MWt (~13%)	\$874M (2012 dollars)	<ul style="list-style-type: none"> • Reactor feedwater pump turbines retrofitted • HP turbine replaced • Generator stator and rotor refurbished • Replaced existing condensate demineralizers with new full-flow filtration skid • Second, third, and fourth point FWHs replaced (nine total) • Cross around relief valves replaced • Main power transformer replaced • Local transmission system upgraded and capacitor banks installed for reactive power requirements • Steam dryer replacement

5. FINANCIAL MODEL DEVELOPMENT

5.1 Introduction

The IRA provides unprecedented federal investment to ensure the United States remains the global leader in clean energy technology, manufacturing, and innovation. Since the late 2020 timeframe, high inflation has impacted the business case for all construction projects, particularly in the power industry. As discussed in Section 3.1, the IRA includes a number of relevant tax credits for NPPs (including hydrogen cogeneration) to counteract inflation. The purpose of this analysis is to demonstrate the impact of these tax credits on the business case for uprating existing NPPs using a case study and provide insights on key drivers and sensitivities of various inputs that will help inform overall decision-making through the power uprate and hydrogen cogeneration process.

The financial model developed for this effort utilizes a range of variable inputs (e.g., capital costs, fuel costs, increased generation, plant lifetime including consideration of subsequent license renewal) to produce relevant outputs that will assist utilities with performing site-specific business case assessments for power uprate and hydrogen cogeneration. That is, it is expected that utilities will perform plant-specific power uprate feasibility studies that identify potential levels of increased generation and corresponding levels of investment required to achieve increased power production. The findings documented herein will allow utilities to use their plant-specific findings to understand the potential financial implications of power uprate and hydrogen cogeneration considering the IRA tax credits. This model should be used as a supplement or screening tool in addition to plant-specific financial models.

5.2 Financial Modeling Methodology

5.2.1 General Overview

As discussed in Section 2, power uprates have been widely implemented in the nuclear industry over the past 40 years. As a result, the impacts of power uprate are well understood. In general, power uprate entails an increase in thermal core power achieved through a variety of methods depending on reactor-type and site-specific characteristics (see Section 4.1). The increase in thermal power results in changes to other parameters, such as system flow rates, pressures, and temperatures. As a result, a number of plant modifications are typically required, especially for EPU. Thus, at a high-level, power uprate will require incremental operational costs associated with fuels (to increase thermal power) and capital projects (to support any plant modifications). These modifications typically take place over one or two refueling outages before power uprate is implemented. The historical business case for power uprate is positive return on upfront capital investment through increased generation over the plant's lifetime.

Unlike power uprate, hydrogen cogeneration with an NPP is a relatively immature concept with initial pilot efforts currently ongoing as discussed in Section 3.3. However, the general financial modeling concept is similar to power uprate. That is, hydrogen cogeneration with an NPP requires tie-in with the plant to deliver thermal and electrical energy from the NPP to the hydrogen facility. Thus, the hydrogen facility will include capital costs for the facility itself, impacts to the existing NPP via the tie-in, and operating and maintenance costs for the facility itself, which will produce hydrogen to be sold. Two electrolysis technologies are considered for this integration with NPPs for this study: LTE and HTE. Summaries of the LTE and HTE technologies (and subsequent costs) are also provided in Appendix B. This model provides a detailed baseline set of hydrogen cogeneration inputs that are used to calculate the gross hydrogen production, project capital costs, and project operating costs. The inputs and methodology are based off prior research to give readers a high-level understanding of the effects of the IRA since hydrogen cogeneration is a relatively new concept in the industry. In lieu of these inputs and methodology, users may also simply directly input the gross hydrogen production, capital costs, and operating costs into the relevant cells if they have alternative models or data.

5.2.2 Model Approach

To model the financial impact of the IRA tax credits on power uprate and hydrogen cogeneration, a Microsoft™ Excel–based deterministic tool was developed. The tool utilizes several user-provided inputs to produce a life-cycle cashflow model for various scenarios that demonstrate the financial impact of the IRA tax credits on power uprate and hydrogen cogeneration for both PWRs and BWRs. These scenarios are provided in Table 9.

Table 9. Financial model scenarios.

Scenario #	Generation Type	IRA Tax Credits ⁽³⁾
1	Power Uprate Only	No IRA
2	Power Uprate Only	ITC (48E)
3	Power Uprate Only	Power PTC (45Y)
4	Power Uprate + LTE H ₂ ⁽¹⁾	No IRA
5	Power Uprate + LTE H ₂ ⁽¹⁾	ITC (48E) + Hydrogen PTC (45V)
6	Power Uprate + LTE H ₂ ⁽¹⁾	Power PTC (45Y) + Hydrogen PTC (45V)
7	Power Uprate + HTE H ₂ ⁽²⁾	No IRA
8	Power Uprate + HTE H ₂ ⁽²⁾	ITC (48E) + Hydrogen PTC (45V)
9	Power Uprate + HTE H ₂ ⁽²⁾	Power PTC (45Y) + Hydrogen PTC (45V)

^{1.} LTE H₂ = Low-Temperature Electrolysis Hydrogen Production.
^{2.} HTE H₂ = High-Temperature Electrolysis Hydrogen Production.
^{3.} IRA section credit number in parenthesis.

The cashflows are produced on an incremental basis such that the investments, expenses, credits, and revenues only consider the new projects and associated added generation (i.e., uprated power and hydrogen cogeneration). The cashflows associated with the initial plant generation (prior to power uprate) are not included. One exception, however, is the generation loss due to the incremental outage time required for EPU construction (if applicable); the negative impact of this loss is included in the model. This concept is similar to utilities purchasing “replacement power” for extended outage durations, where replacement power is typically the market value of power over that time period minus plant operating costs (i.e., lost generation net revenue). The model begins at the start of the initial capital spend for the power uprate and hydrogen facility and completes at the end of plant operations.

A complete list of inputs and detailed descriptions are provided in the financial model, and key inputs to the model are:

- Uprate capital, operations and maintenance (O&M), and fuel^e costs
- Hydrogen capital, O&M, and feedstock costs (e.g., process water)
- Uprate generation parameters (e.g., MWe added, capacity factor)
- Hydrogen cogeneration parameters (e.g., thermal and electrical consumption, capacity factor)
- Financing parameters (e.g., interest rates, debt-to-equity ratio, target equity rate of return)
- Relevant income tax parameters (e.g., effective tax rate, asset depreciable life)
- IRA tax credit values and eligibility criteria

^e Fuel cost inputs are the incremental fuel costs for the uprated power (i.e., independent of traditional fuel, ATF, or LEU+). Users may run sensitivities on various fuel types to examine potential benefits for utilizing advanced fuels to help achieve power uprate. See APPENDIX C for more information.

- Escalation inputs
- Power and hydrogen sale prices.

Each cashflow scenario is used to calculate the following outputs, which are intended to span the needs of decision makers for various power-producing entities. While the below metrics provide a wide picture of the impact of power uprate and hydrogen cogeneration, individual utilities will likely have other metrics of interest specific to their operation (e.g., customer rate impact) that should also be analyzed and considered when pursuing these large capital endeavors. As previously stated, this tool is simply provided as a high-level supplemental screening mechanism.

- **Present Value of Revenue Requirements, PVRR (\$000s):** Defined as the cash inflow from power sales required to achieve the required investor returns after operating costs, income taxes, tax credits, and hydrogen sale revenues. The PVRR is calculated using the weighted average cost of capital (WACC) as the discount rate. A negative number indicates that no power sales are required to achieve the required investor returns (i.e., the tax credits and hydrogen sale revenues are greater than the costs and taxes).
- **Internal Rate of Return, IRR (%):** Defined as the discount rate that results in a net present value (NPV) of zero for a given cashflow (i.e., rate of return on investment).
 - **Project IRR:** The IRR of a cashflow that includes the total investment, all revenues, expenses, taxes, and credits, but does not include financing costs (i.e., free cash flow to firm). The project IRR is often compared to the WACC to assess a project’s business case or, in some cases, is compared to a risk-adjusted hurdle, which includes the WACC plus an additional project-specific risk-adjustment term.
 - **Equity IRR:** The IRR of a cashflow that includes the equity investment only, all revenues, expenses, taxes, credits, and financing costs (i.e., Free Cash Flow to Equity). The equity IRR is often compared to the target return on equity to assess a project’s business case. Project-specific return on equity is typically not a significant metric of interest for large capital nuclear projects as bonds are typically used as a significant source of financing. However, it is included in this model in an effort to provide flexibility and a larger range of output metrics for the intended audience.
- **Levelized Cost of Electricity, LCOE (\$/MWh):** Defined as the NPV of future cashflows (excluding electricity revenue) divided by the NPV of the life-cycle electricity generation over the remaining plant life. Alternatively, the LCOE is the sale price of electricity that, if charged at a constant value over the operating life, would result in electricity revenues that cover the initial investment, operating expenses, taxes, and costs of capital and provide zero excess return (i.e., the “breakeven” price).
- **Levelized Cost of Hydrogen, LCOH (\$/kg):** Defined as the NPV of future cashflows (excluding hydrogen revenues) divided by the NPV of the life-cycle hydrogen cogeneration over the remaining plant life. Alternatively, the LCOH is the sale price of hydrogen that, if charged at a constant value over the operating life, would result in hydrogen revenues that cover the initial investment, operating expenses, taxes, and costs of capital and provide zero excess return (i.e., the “breakeven” price).

A simplified schematic demonstrating the financial model flow chart is provided in Figure 17. Detailed descriptions of each of the model sheets used to generate this cashflow analysis are provided in APPENDIX A.

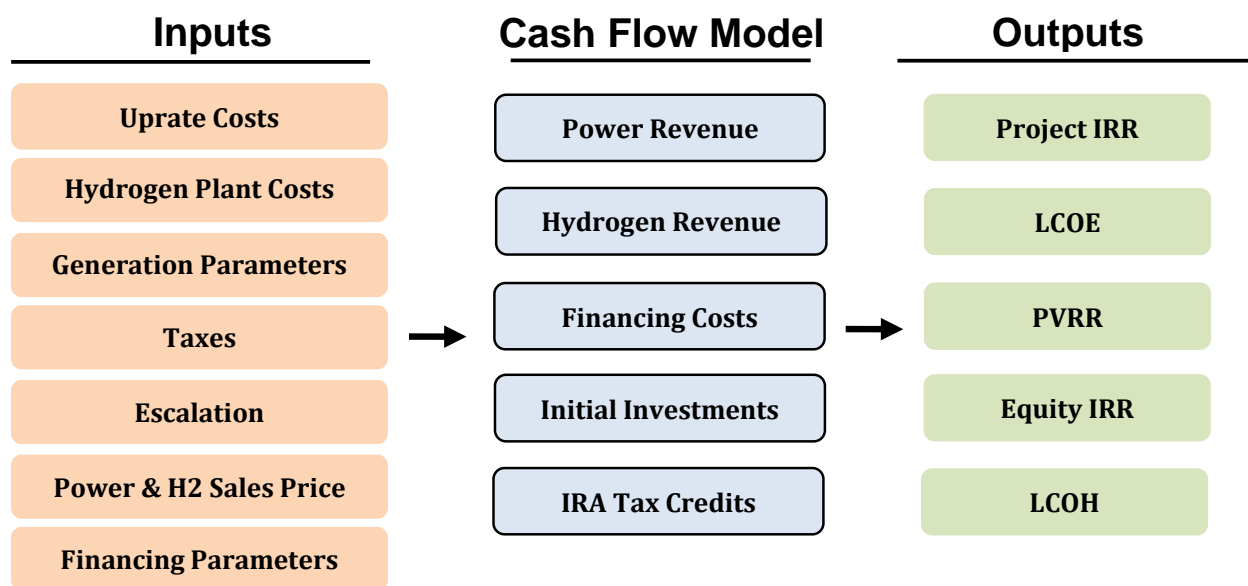

Figure 17. Financial model flow chart.

5.2.3 Cashflow Model Methodology

This section provides the methodology used in the cashflow model for calculating the outputs listed in Section 5.2.2. For each scenario, the cashflow model utilizes the user-provided inputs to produce annual cashflows for various cost components listed in Table 10.

Table 10. Model annual cashflow components.

Cashflow Component ¹	Description
Debt Investment Cashflow, D	The overnight capital expenditures (CAPEX) input is time-phased over the project period based on the project spend curve, project start date, and construction end date inputs. Escalation is applied based on the escalation inputs, resulting in an escalated CAPEX cashflow. The debt investment cashflow and equity investment cashflow is then calculated using the debt-equity ratio input.
Equity Investment Cashflow, E	
Hydrogen Revenue Cashflow, RH	The escalated hydrogen sale price is calculated for each period using the hydrogen sale price and escalation inputs. The hydrogen revenue cashflow is then calculated using the escalated hydrogen sale prices and annualized hydrogen production input.
Power Revenue Cashflow, RP	The escalated power sale price is calculated for each period using the power sale price and escalation inputs. The power revenue cashflow is then calculated using the escalated power sale prices and annualized power generation input.
Operational Expenditures (OPEX) Cashflow, O	The OPEX cashflow uses the added OPEX and escalation inputs.

Table 10. (continued).

Cashflow Component ¹	Description
Income Taxes Cashflow, T	The depreciation in each period is calculated using the total capitalized cost, depreciable life, depreciable basis reduction, and declining balance factor inputs. The taxable income in each period is calculated as the sum of the revenues and OPEX, less depreciation. The income taxes cashflow is then calculated using the effective tax rate input and taxable income in each period.
Tax Credits Cashflow, C	For scenarios using the ITC, the ITC value is calculated using the uprate total capitalized cost and the net ITC percent inputs. The ITC is applied in the first year of operations. The benefit of the ITC may be normalized over the useful life of the asset. That is, the utility would receive the benefit in the first year of operations, but that benefit may be passed on to ratepayers over the useful life of the NPP through reduced power rates. This model simply provides the benefit the year that the ITC is claimed. For scenarios using the PTC (hydrogen or power), the escalated PTC value is calculated for each period using the net PTC value and escalation inputs. The PTC cashflow is then calculated using the escalated PTC value and annualized power (or hydrogen) generation input. The PTCs are applied to the first 10 years of operation after uprate.
Debt Financing Cashflow, F	The interest during construction is calculated using the return on debt input and the debt investment cashflow. The total debt at commercial operation date (COD) is the sum of the debt investment cashflow and interest during construction. The principal and interest debt payments for all periods are calculated using the total debt at COD, debt interest rate, and debt repayment term. The debt interest tax shield is calculated using the debt interest payments and effective tax rate input. The debt financing cashflow is the sum of the principal and interest payments, less the debt interest tax shield.
NOTE 1: For all components, cash outflows are negative and cash inflows are positive.	

Project IRR and Equity IRR

The components in Table 10 are combined to form the project cashflow, PCF , and equity cashflow, ECF :

$$PCF = D + E + R_H + R_P + O + T + C$$

$$ECF = E + R_H + R_P + O + T + C + F$$

The **project IRR**, IRR_{proj} , and **equity IRR**, IRR_{Eq} , are then calculated as follows (the Microsoft™ Excel-based IRR function is denoted with “ $irr(X)$ ”, where X is the cashflow used):

$$IRR_{proj} = irr(PCF)$$

$$IRR_{Eq} = irr(ECF)$$

LCOE, LCOH, and Present Value of Revenue Requirements (PVRR)

The common equation for calculating the **LCOE**, L_E , is as follows:

$$L_E = \frac{PVRR}{PVG_E}$$

Where $PVRR$ is the **Present Value of Revenue Requirements** and PVG_E is the present value of the time-phased lifecycle power generation of the plant. The Revenue Requirements, RR , represent the (negative) lifecycle costs of the plant. For the purposes of this analysis, additional terms are added to capture the benefits of IRA tax credits, C , and hydrogen revenue, R_H . The Microsoft™ Excel-based NPV function is denoted with “ $npv(r, X)$ ”, where r is the discount rate and X is the cashflow used.

$$RR = -(D + E + R_H + O + T + C)$$
$$PVRR = npv(r, RR)$$

The discount rate used is the input for After-Tax Weighted Average Cost of Capital, $ATWACC$. As such, the resulting **LCOE** expresses the minimum price required for electricity, if charged at a constant value throughout operations, such that the net cashflows are sufficient to cover the cost of capital. As a result, the **LCOE** is calculated as follows:

$$L_E = \frac{npv(ATWACC, RR)}{npv(ATWACC, G_E)}$$

LCOH, L_H , is calculated similarly, but instead of capturing hydrogen revenue, power revenue, R_P , is used, and instead of using lifecycle power generation, lifecycle hydrogen generation, G_H , is used.

$$L_H = \frac{npv(ATWACC, -(D + E + R_P + O + T + C))}{npv(ATWACC, G_H)}$$

5.3 Case Study

5.3.1 Overview

A case study was analyzed to assist with demonstrating the value of the IRA tax credits and to conduct sensitivities on key inputs. The inputs for this case study were informed by operating experience provided by utility partners, industry subject matter experts, and tax consultants. Additionally, sensitivity studies are run for the case study that examine the impact of varying key inputs, such as power pricing, overnight capital costs, and escalation rates, on key output metrics, such as **LCOE** and **IRR**.

The case study examines a PWR looking to implement a power uprate of approximately an 8% increase in power output (in this case an GPU uprate because significant plant modifications are required). The plant has just entered the first period of extended operations (i.e., is approximately 40 years old) and recently decided to pursue SLR, which will extend the remaining operating lifetime of the plant by an additional 20 years. This pursuit of SLR is expected to include modifications to several key components. As a result, the site is interested in pursuing EPU due to the ability to synergize costs associated with extended plant lifetime and power uprate. The plant is also considering hydrogen cogeneration but has not yet done any detailed studies. Thus, the plant will utilize the baseline values and methodology provided in APPENDIX B as a high-level estimate of hydrogen costs and revenues.

5.3.2 Inputs

Key inputs associated with this case are provided in Table 11. These inputs were generated primarily based on industry operating experience input to generate reasonable values that allow comparisons of the impact of the IRA tax credits. That is, the gross values provided herein should not be considered “all-encompassing” but rather reasonable from a perspective of evaluating the impact of the tax credits on output metrics, such as LCOE and IRR. Sensitivities for key inputs are evaluated and discussed in Section 5.3.4. Full summaries of the inputs used in the financial model are provided in APPENDIX A.

Table 11. Case study key inputs.

Input	Value
Uprate Overnight CAPEX	\$500,000,000
LTE Overnight CAPEX	\$76,015,000
HTE Overnight CAPEX	\$114,058,000
Electrical Capacity Added	100 MWe
Remaining Plant Life as of 1/1/23	40 years
Project Start Date (start of spend)	1/1/25
Construction Start Date (1 st construction outage)	3/1/28
Number of Outages for Construction	2
Outage Impact	Additional 5 days per outage
Construction End Date / COD	10/31/29
Debit Equity Ratio	1:1
Average Power Price	\$40/MWh
Return on Debt	5%
Target Post-Tax Return on Equity	10%
Debt Repayment Term	30 years
Effective Tax Rate	23.5%
Escalation	Sample Values (see APPENDIX A)

The IRA tax responses used for this case study are documented in Table 12. In this case, the plant will meet two requirements that significantly increase the impact of the uprate PTC and ITC (baseline values of \$3/MWh in 1992 dollars and 6% of the qualified investment, respectively, as discussed in Section 3.1).

Table 12. Case study IRA tax questions.

Input	Response
IRA—Prevailing Wage & Apprenticeship Requirements Met?	Yes
IRA—Project in Energy Community?	No
IRA—Domestic Content Requirement Met?	Yes
IRA—Use Direct Payment for ITC?	No
Tax-Exempt Financing Reduction?	No
PTC Market Haircut ¹ (% lost)	0%
ITC Market Haircut ¹ (% lost)	0%
ITC Cost Basis Reduction (% removed)	0%
Total Uprate PTC Value	~\$32/MWh in 2022 dollars

Input	Response
Total Uprate ITC Value	40% of capitalized costs
Total Hydrogen PTC Value	\$3.00/kg
¹ . “Haircut” refers to a reduction in the initial market value of the tax credit as a result of an open market transfer of the credits (see Section 3.1).	

5.3.3 Results

Utilizing the set of inputs documented in APPENDIX A, the model was iterated to examine the results for the case study. The results are summarized in Table 13 (IRR, capital costs, LCOE, and LCOH), Table 14 (PVRR), and Figure 18 (plot of capital costs, project IRR, and PVRR). Key takeaways from the base case study run are:

- The power uprate ITC and PTC tax credits have a significant impact on overall project financials.
 - In this case study, power uprate is projected to have a positive return without the tax credits, but be short of the target returns.
 - Both the ITC and PTC credits generate a greater return that increases the IRR above the target threshold and significantly decrease the LCOE.
 - In this case, the ITC and PTC provide similar benefits, with the ITC providing a slightly higher return.
 - Similarly, the ITC and PTC significantly decrease the total PVRR and corresponding LCOE that are needed to meet capital requirements over the plant lifetime—in this case, the PVRR and LCOE are approximately 60% of the baseline metrics without considering the IRA.
- In this case study, hydrogen cogeneration presents a strong business case when leveraging the IRA benefits.
 - Specifically, for the inputs documented in Appendix A, the IRR for the hydrogen cogeneration scenarios is significantly higher than when using the uprated power strictly for electricity generation.
 - Without the IRA, the expected returns are low and below target thresholds.
 - In this case, the largest return is seen for HTE, increasing project IRR by more than 150% from the power-only scenarios.

Table 13. Case study summary of results—IRR, capital costs, LCOE, and LCOH.

	Project IRR ¹	Equity IRR ²	Total Capitalized Project Costs ³ (\$000s) Then-Year Dollars	LCOE ⁴ (\$/MWh) 2023 Dollars	LCOH ⁴ (\$/kg) 2023 Dollars
Uprate Only Scenarios					
No IRA	5.13%	6.03%	\$631,568	\$72.69	No Hydrogen Gen
ITC	8.30%	14.14%	\$631,568	\$45.40	No Hydrogen Gen
Power PTCs	8.17%	12.05%	\$631,568	\$44.66	No Hydrogen Gen
Uprate + LTE H2NA					
No IRA	1.05%	0.00%	\$775,466	No Power Gen	\$5.31
ITC + H ₂ PTCs	9.83%	19.09%	\$775,466	No Power Gen	\$1.34
Power PTCs + H ₂ PTCs	9.48%	15.88%	\$775,466	No Power Gen	\$1.30
Uprate + HTE H₂					
No IRA	1.99%	0.00%	\$847,483	No Power Gen	\$4.46
ITC + H ₂ PTCs	11.76%	21.92%	\$847,483	No Power Gen	\$0.88
Power PTCs + H ₂ PTCs	11.18%	18.60%	\$847,483	No Power Gen	\$0.85
^{1.} IRR to the firm by considering the total investment (equity and debt) and the future cashflows, not including financing costs. This is equivalent to the IRR for a project with 100% equity financing. ^{2.} IRR to equity shareholders when considering just the equity investment and future cashflows, including financing costs. ^{3.} Total capitalized project cost, including escalation and interest incurred during construction. Costs are expressed in then-year dollars. ^{4.} The LCOE and LCOH are the required average prices (for either power or hydrogen) to achieve the required investor returns after operating costs, income taxes, tax credits, and revenues from sale of the opposite commodity if applicable (e.g., LCOE is calculated using revenues from hydrogen sales). The LCOE and LCOH are calculated assuming this price remains constant throughout operations (no escalation). This price is expressed in “results basis year” dollars. For example, if the LCOE calculation in the cash flow results in \$110/MWh, the “results basis year” is 2023, and the “COD” is in 2029, the LCOE presented in the results table is calculated as \$110/MWh (escalation from 2023 to 2029).					

Table 14. Case Study Summary of Results—PVRR.

Present Value of Revenue Requirements ⁵				
Capital Costs (\$000s) 2023 Dollars (A)	Expenses & Income Taxes (\$000s) 2023 Dollars (B)	H ₂ Revenue (\$000s) 2023 Dollars (C)	IRA Benefit (\$000s) 2023 Dollars (D)	Total (\$000s) 2023 Dollars (A + B + C + D)
\$467,592	\$121,200	\$0	\$0	\$588,792
\$467,592	\$69,254	\$0	(\$169,103)	\$367,743
\$467,592	\$67,844	\$0	(\$173,691)	\$361,745
\$574,129	\$233,091	(\$376,831)	\$0	\$430,390
\$574,129	\$89,502	(\$376,831)	(\$467,427)	(\$180,627)
\$574,129	\$88,093	(\$376,831)	(\$472,016)	(\$186,625)
\$627,448	\$308,104	(\$519,049)	\$0	\$416,502
\$627,448	\$129,929	(\$519,049)	(\$580,014)	(\$341,690)
\$627,448	\$128,519	(\$519,049)	(\$584,606)	(\$347,688)

⁵. Revenue requirements represent the cash inflow from power sales that is required to achieve the required investor returns after operating costs, income taxes, tax credits, and H₂ sale revenues. The present value of future revenue requirements is calculated using the “WACC” as the discount rate.

Total Capital Costs		Project IRR		LCOE (\$/MWh)		LCOH (\$/kg)	
Uprate Only	\$631,568	No IRA	5.1%	\$72.69	No H2 Gen		
		ITC	8.3%	\$45.40	No H2 Gen		
		Power PTCs	8.2%	\$44.66	No H2 Gen		
Uprate + LTE	\$775,466	No IRA	1.1%	NA	No H2 Gen	\$5.31	
		ITC + H2	9.8%	NA	No H2 Gen	\$1.34	
		Power PTCs + H2	9.5%	NA	No H2 Gen	\$1.30	
Uprate + HTE	\$847,483	No IRA	2.0%	NA	No H2 Gen	\$4.46	
		ITC + H2	11.8%	NA	No H2 Gen	\$0.88	
		Power PTCs + H2	11.2%	NA	No H2 Gen	\$0.85	

Figure 18. Summary of capital costs (\$000s), project IRR, LCOE, and LCOH.

5.3.4 Sensitivity Analyses

The results documented for the case study are dependent on a number of specific inputs as documented in Appendix A. To help identify key inputs as well as to investigate the effects of certain parameters (e.g., IRA credit timing or uprate capital cost), a number of sensitivity cases were run. This section documents key findings from these sensitivity analyses (note the model provides more sensitivities than are discussed herein).

Note that, for each sensitivity case, the results ranges are typically depicted for 2–3 inputs; however, all other inputs (that are not varied) are as listed in Appendix A. As expected, the sensitivity studies indicate that the results are highly sensitive to some inputs, and the outer bounds of certain input ranges suggest there may not be a business case for certain scenarios. As such, it is important for the user to understand **all** the inputs when drawing conclusions from the sensitivity plots. Finally, note that negative or unsolvable IRR values are replaced with zero in the charts shown herein.

5.3.4.1 Uprate Only Sensitivities

Figure 19 depicts LCOE (\$/MWh) versus overnight uprate cost per MWe (\$000/MWe). The sensitivity analysis demonstrates that the power PTC provide great benefit than the ITC at lower CAPEX per MWe ranges. The value of the ITC is proportional to the capital costs, and the overall value of the PTCs is proportional to the generation output; therefore, when capital costs are low or expected generation increase is high, the PTC provides more value than the ITC. In the specific example shown, the firm would likely elect the power PTC at or below the uprate cost of \$5,250/MWe to minimize LCOE. However, should uprate costs exceed \$5,250/MWe, it would likely elect to leverage the ITC.



Figure 19. Case Study Sensitivity 1.

Key inputs that can significantly affect the output metrics include (but are not limited to) power pricing, CAPEX per MWe, and plant lifetime. As shown in Figure 20, power pricing at the lower end of the sensitivity range (i.e., \$20/MWh) only exceeds the target post-tax return on equity of 10% for lower CAPEX per MWe ranges (i.e., below approximately \$4000/MWe). Similarly, as shown in Figure 21, the remaining plant life is an

increasingly sensitive parameter as the uprate costs per MWe increase. Generally speaking, the longer life a plant has left and the lower power prices are, the more profitable added hydrogen becomes.

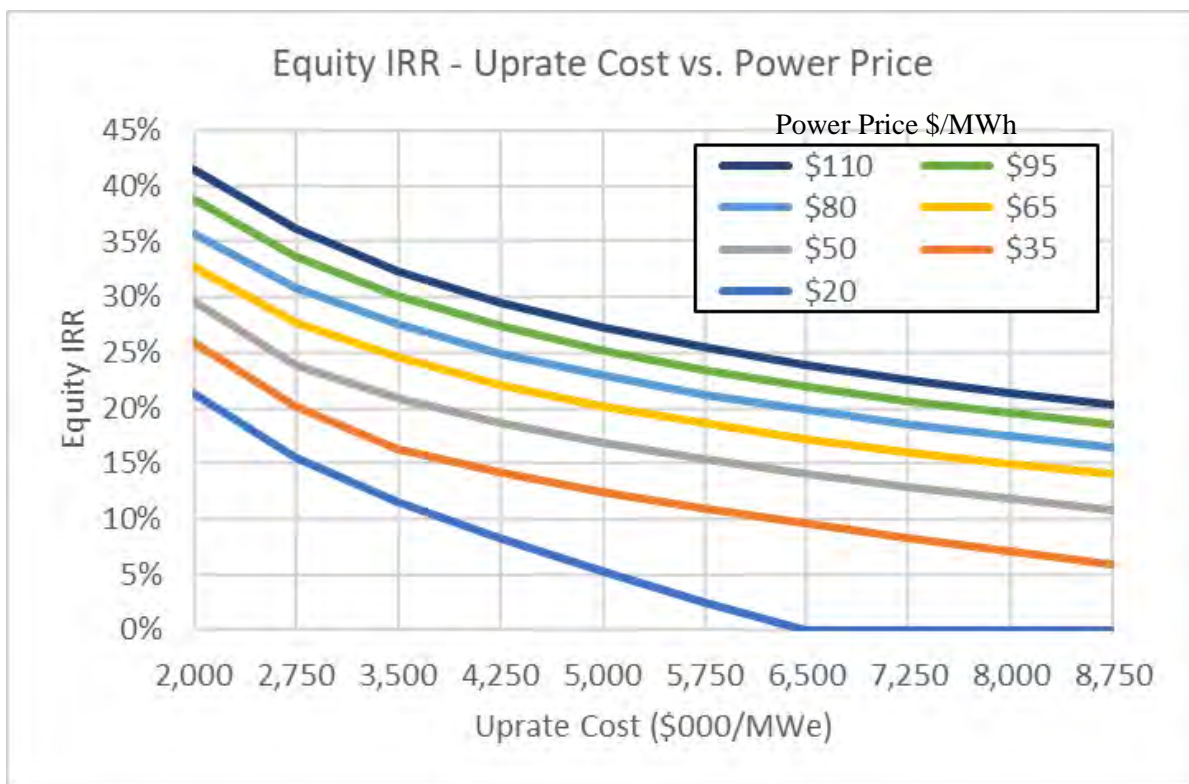

Figure 20. Case Study Sensitivity 2.

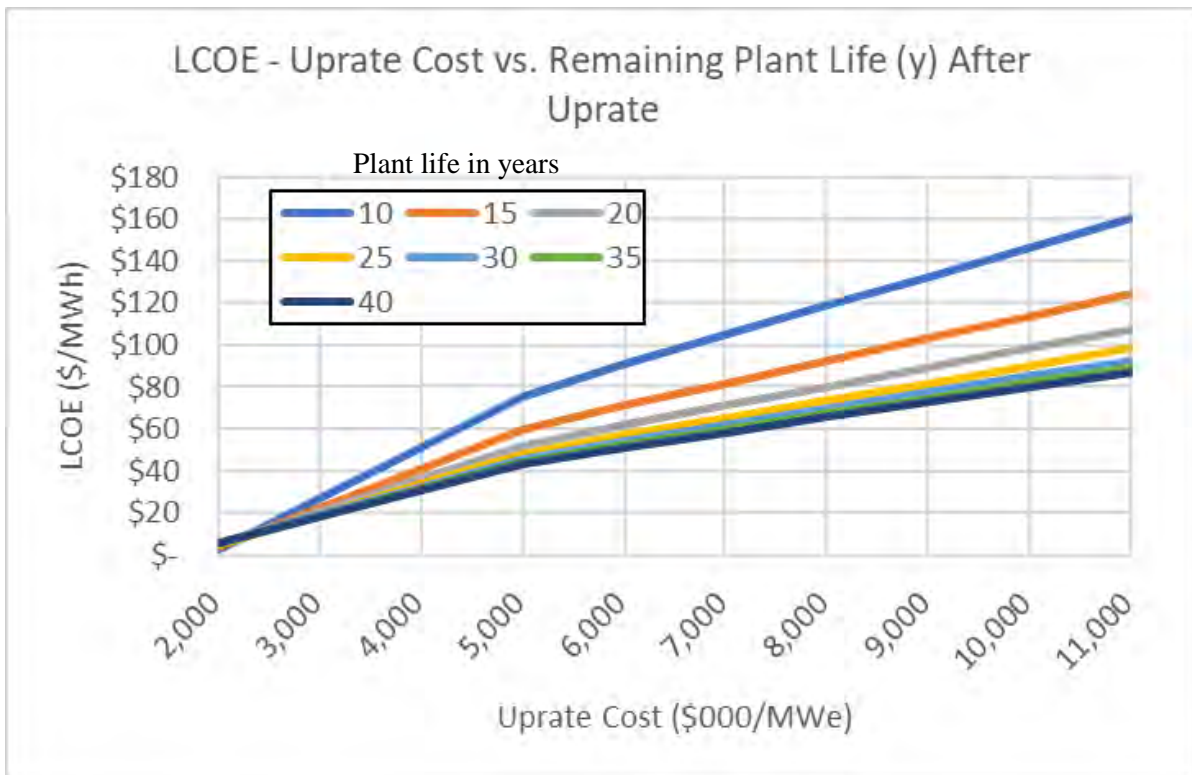

Figure 21. Case Study Sensitivity 3.

Additionally, as expected, recent high inflation has the potential to significantly impact the business case for uprate projects. Figure 22 plots uprate construction escalation in the years prior to uprate implementation versus equity IRR. As can be seen, the return can be significantly impacted (in this example doubling the equity IRR in the case of ITC election); however, the IRA tax credits are shown to be a significant mitigation measure to counteract the inflation, increasing returns to near or above the target level.

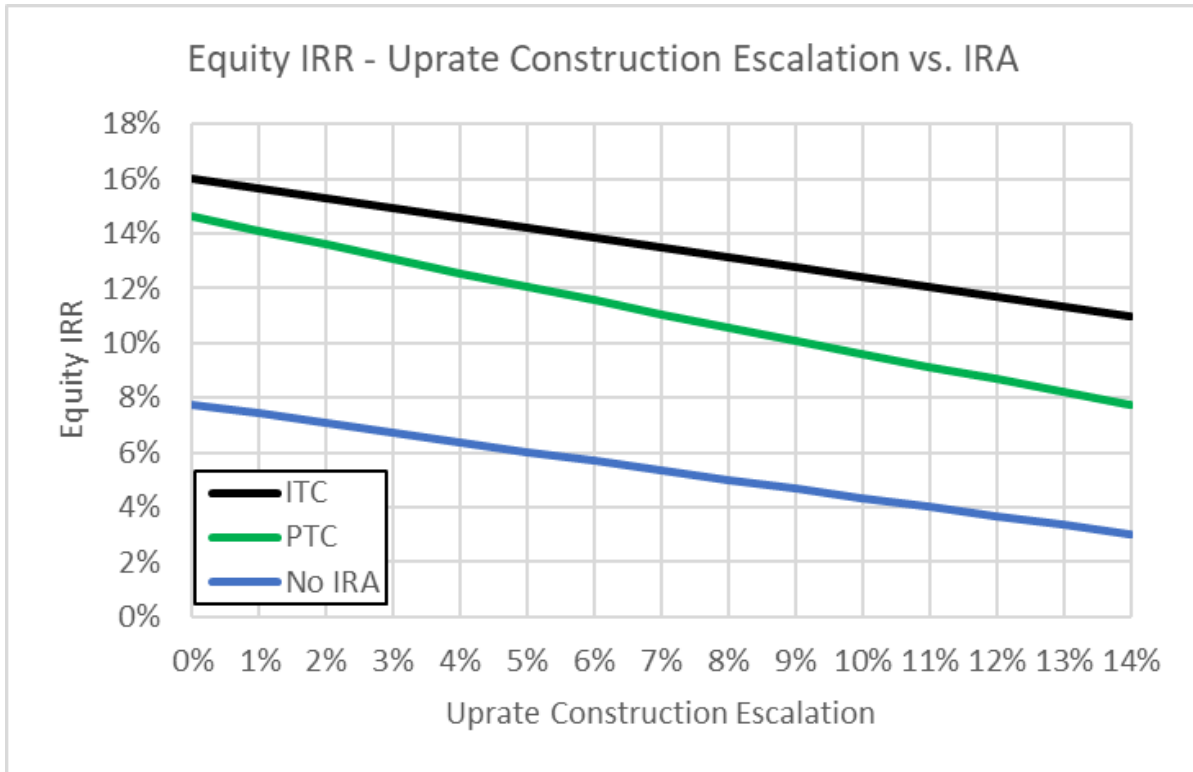

Figure 22. Case Study Sensitivity 4.

5.3.4.1.1 Hydrogen Cogeneration Sensitivities

Figure 23 and Figure 24 investigate the percentage of uprated power diverted to hydrogen cogeneration from 0% (no hydrogen cogeneration) to 100% (all uprated power going to hydrogen cogeneration) with and without the IRA. The sensitivity shows, for this case study, that hydrogen cogeneration has a strong business case (i.e., higher expected returns) for a majority of hydrogen cogeneration options, but only with the inclusion of the IRA credits. That is, without the IRA tax credits, power generation is more lucrative for this case study.

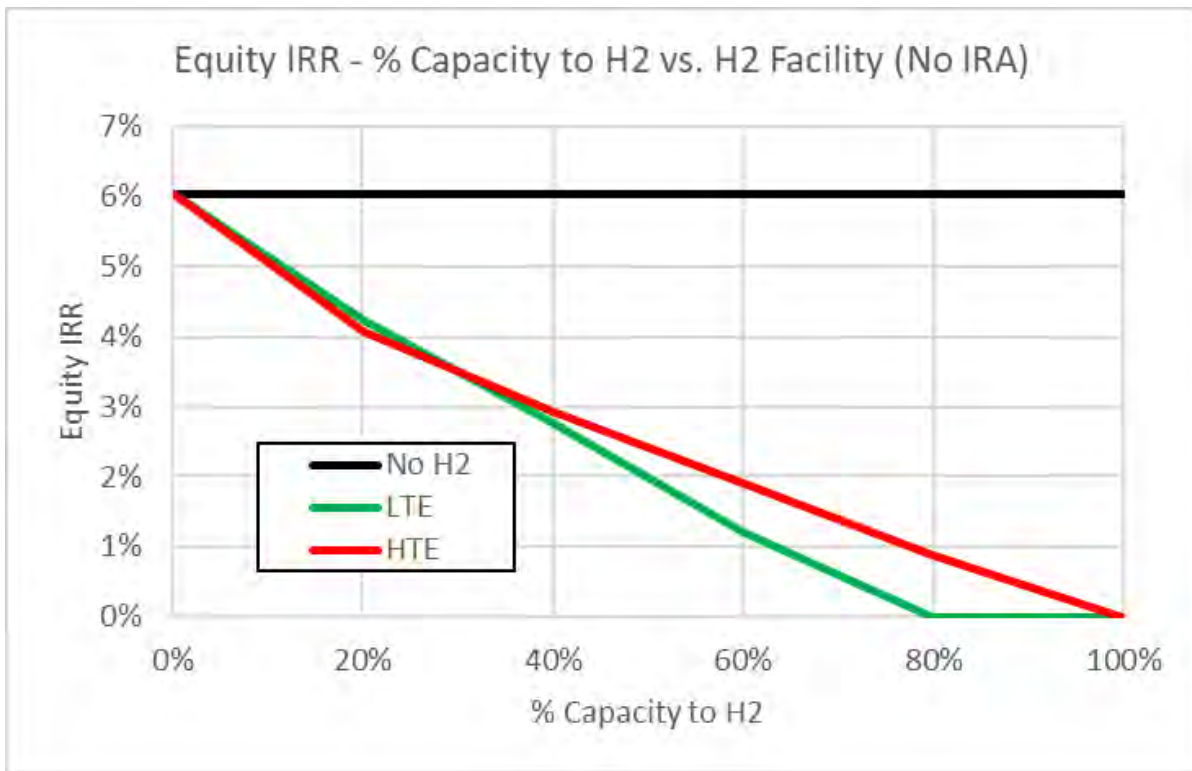

Figure 23. Case Study Sensitivity 7—no IRA.

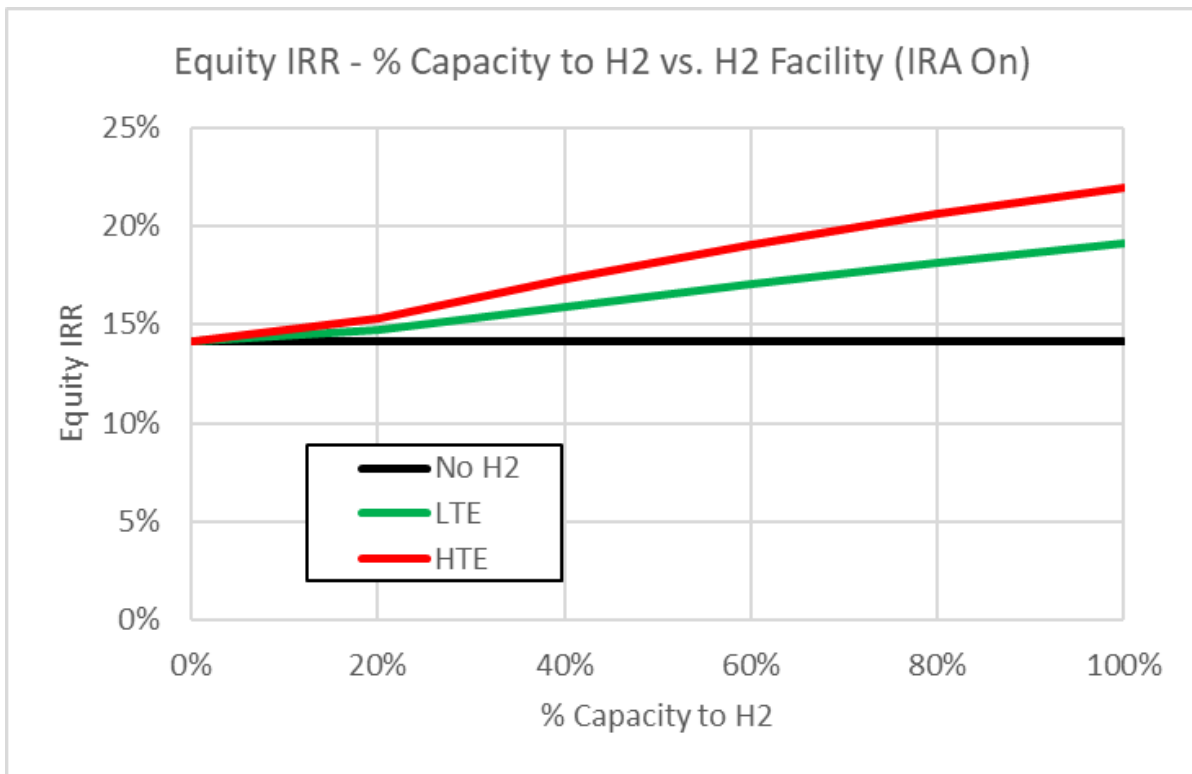

Figure 24. Case Study Sensitivity 7—IRA.

The decision to utilize the uprated power for electricity generation or hydrogen cogeneration (or a mixture) is heavily dependent on power price and hydrogen sales price. As the power price increases, electricity generation becomes more favorable and vice-versa with hydrogen sales price. Figure 25 examines the effect of varying the hydrogen sales price for HTE shown in Figure 24. The curve shows the significant impact the hydrogen generation sales price can have on overall return as more uprate capacity is diverted to hydrogen cogeneration for this case study. Taking this one step further, Figure 26 plots returns for an array of power and hydrogen sale prices. As expected, the more lucrative return transitions from power to hydrogen and vice-versa depending on market conditions. Thus, the user should treat both prices as key inputs to the ultimate decision-making process. Recall again that in this modeling it is assumed that hydrogen is consumed at the plot edge of the NPP and therefore storage, transportation and additional compression is not considered. If this were to be considered hydrogen sales price would increase.

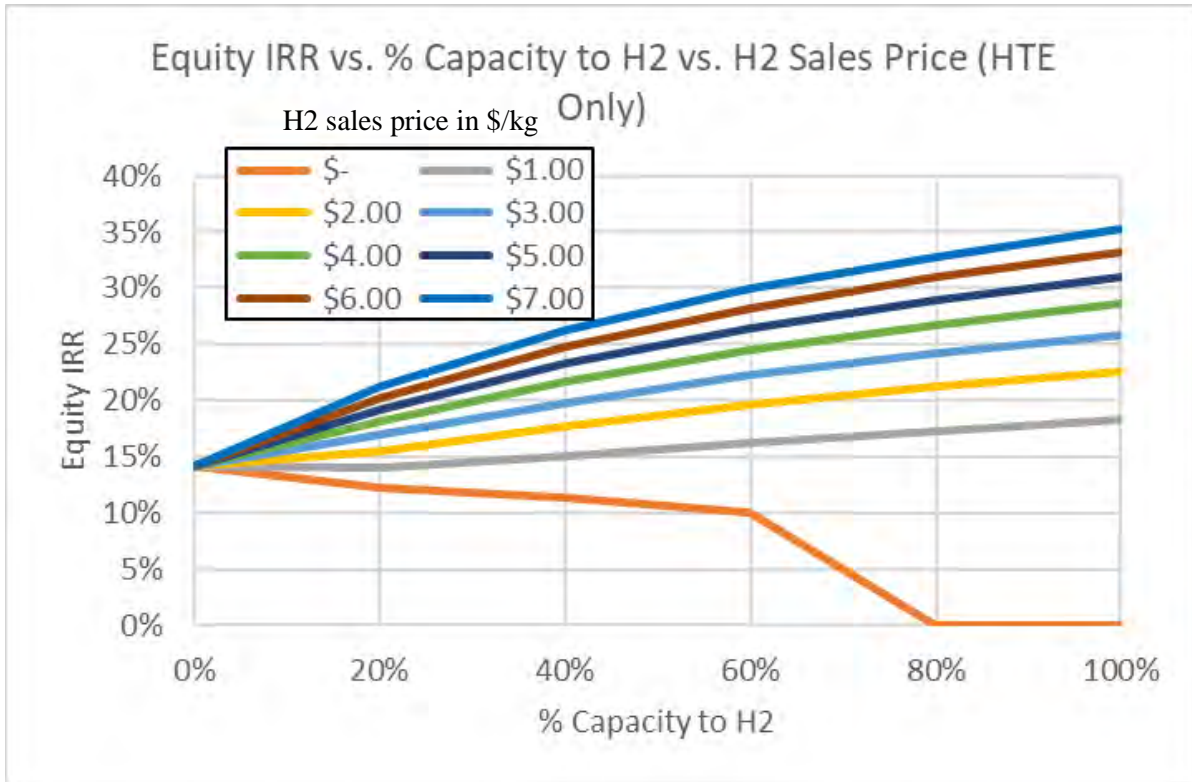

Figure 25. Case Study Sensitivity 8.

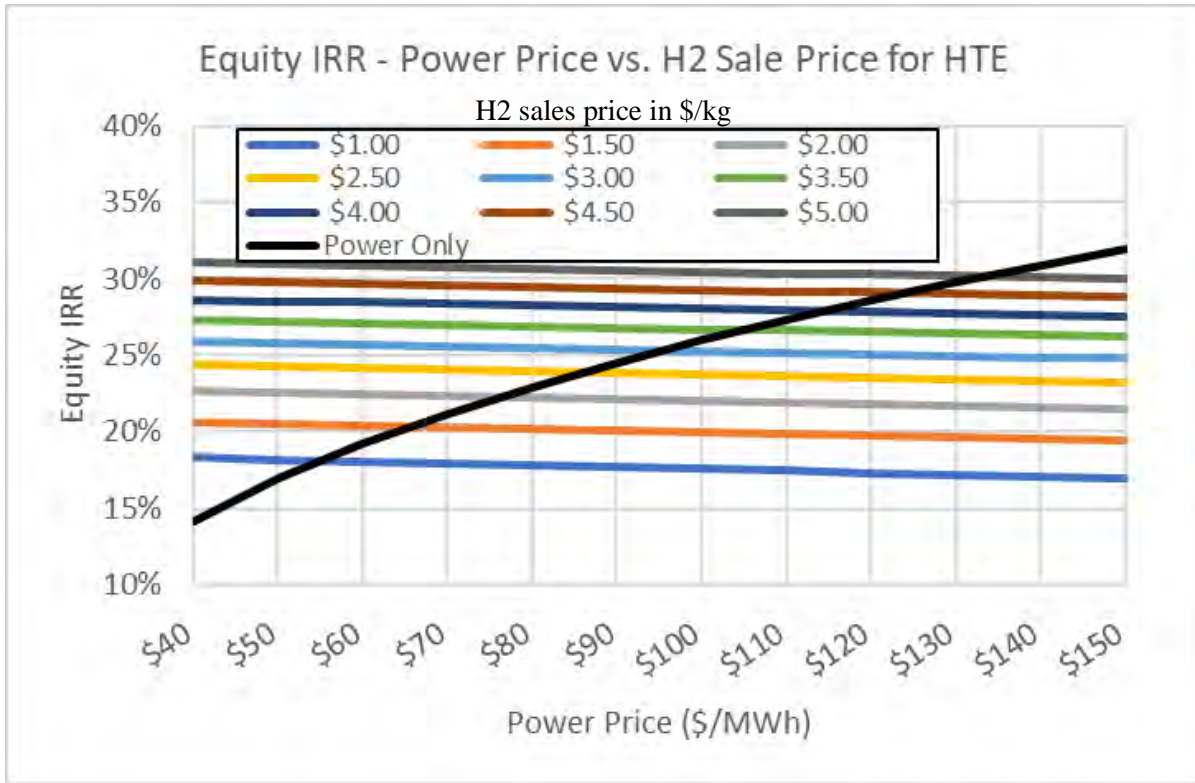

Figure 26. Case Study Sensitivity 9.

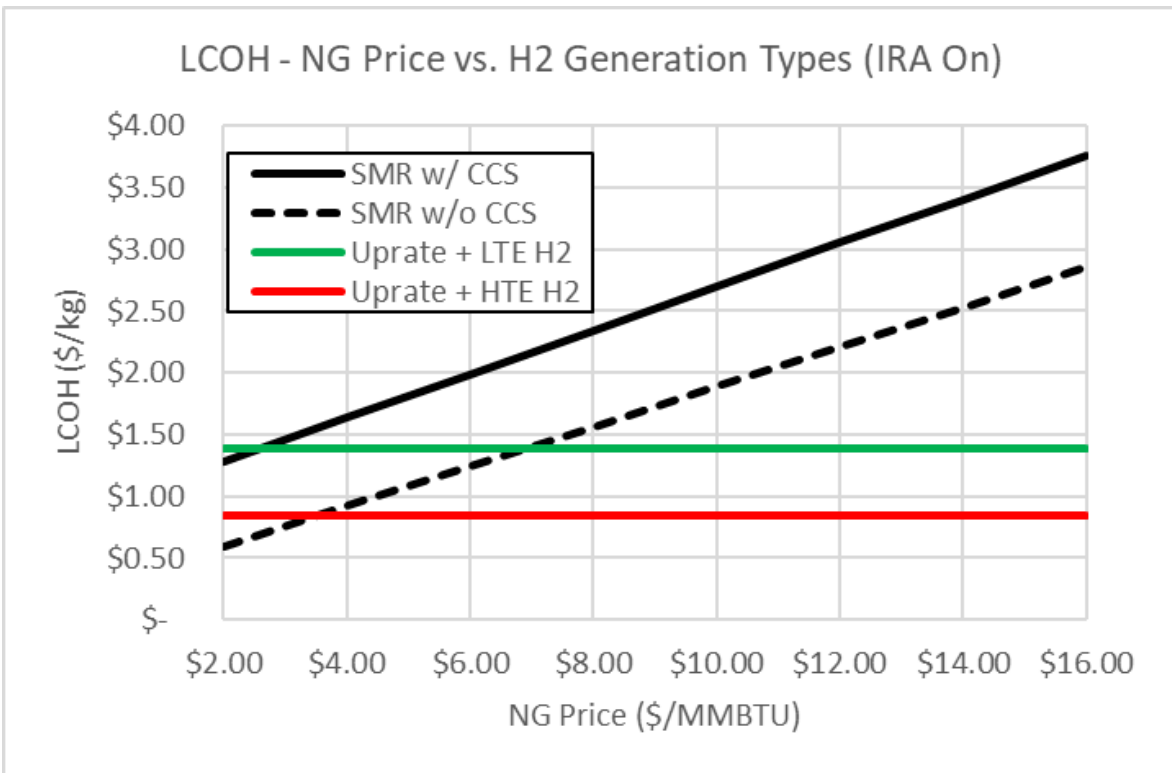

Figure 27. Case Study Sensitivity 10.

Finally, the LCOH results from this case study were compared to the LCOH of SMR plants with and without carbon capture and storage over a range of natural gas prices. The correlation between natural gas price and LCOH for SMRs was developed leveraging the work from [40]. The results are plotted in Figure 27. The plot indicates that hydrogen cogeneration from the uprate is competitive with SMRs over the majority of natural gas prices examined (i.e., \$2–16/MMBTU) for both LTE and HTE technologies. The LCOH difference becomes increasingly favorable for nuclear power as the natural gas price increases as expected.

The results from the figures discussed above highlights that the results of the analysis are sensitive to a number of key variables. To summarize some of the most significant effects, a simplified tornado chart was produced that examines the effect on LCOE from varying certain inputs +/- 25%. The specific inputs analyzed included are listed below with the effect on LCOE plotted in and tabulated in The figure demonstrates the considerable impact capital cost per MWe, WACC, and the tax credit values can have on the overall results. Thus, it is critical utilities identify and iterate through sensitivity analyses with these, and other key variables to understand the range of potential outcomes.

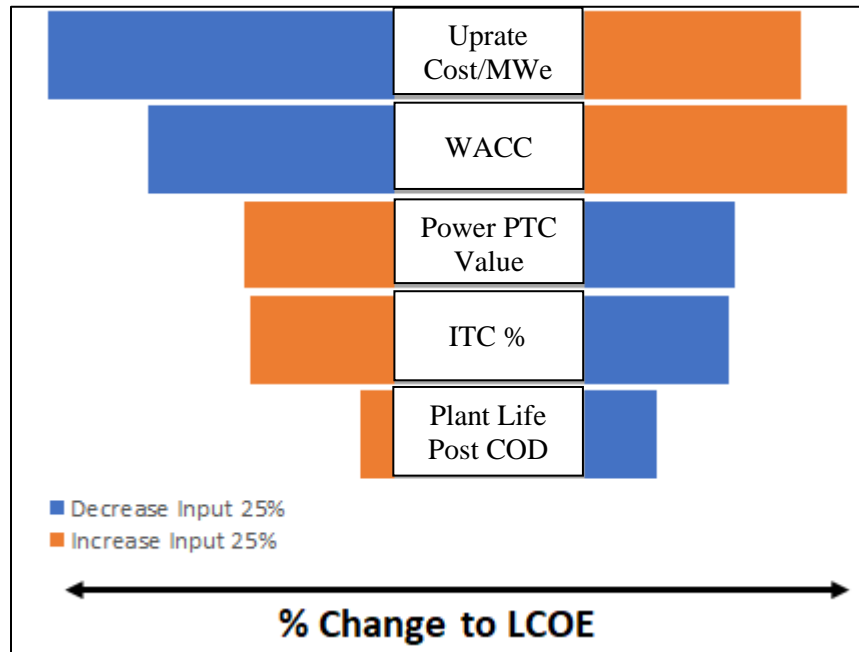

Figure 28. LCOE tornado chart.

The figure demonstrates the considerable impact capital cost per MWe, WACC, and the tax credit values can have on the overall results. Thus, it is critical utilities identify and iterate through sensitivity analyses with these, and other key variables to understand the range of potential outcomes.

Table 15. Summary of tornado chart results

Parameter	LCOE Impact (-25%)	LCOE Impact (+25%)
	Decrease Input by 25%	Increase Input by 25%
Uprate Cost / MWe	-36%	23%
WACC	-26%	28%
Power PTC Value	16%	-16%
ITC %	15%	-15%
Plant Life Post COD	8%	-3%

5.3.4.1.2 Other Considerations

There are a number of other key considerations users should investigate when considering their specific case study, including:

- **Financing Approach**
 - The case study assumed a 1:1 debt-equity ratio for financing the uprate and hydrogen cogeneration projects.
 - A sensitivity study was run assuming the projects are 100% financed through debt, utilizing the same Return on Debt. The sensitivity study indicates the financial output metrics (e.g., project IRR, LCOE) are slightly more favorable to this financing approach. However, if the utility intends to utilize tax-exempt financing (such as tax exempt bonds), a financing reduction of 15% or the fraction of the proceeds of the tax-exempt financing used to provide financing for the facility over the aggregate amount of additions to the capital account for the qualified facility must be considered, whichever is less.
- **Direct Payment or Credit Transfer**
 - If the utility intends to pursue direct payment, then the construction timeline becomes critical if the domestic content bonus is not met (e.g., 100% reduction of credit if construction starts in 2026 or later).
 - Similarly, if the credit is intended to be transferred, a “haircut,” or reduction is expected to be incurred related to the open market sale of the credit.
- **Implementation Timing**
 - The credit phases down to zero over 3 years beginning with the second calendar year after the year the Treasury Secretary determines the annual U.S. GHG emissions from electricity production is equal or less than 25% of GHG emissions in 2022 or 2032, whichever is later.
 - Therefore, if the applicable year is 2032, the full credit amount would be available for 2033, the credit would be reduced to 75% in 2034, 50% in 2035, and 0% in 2036.
 - Utilities should carefully consider implementation timing, including licensing actions, such as the power uprate amendment and any other parallel actions (e.g., fuel switch) that may be dependent on regulatory approval that could delay the implementation timeline.

6. RISK-INFORMED SYSTEMS ANALYSIS

This project evaluated safety assessments required to support sizable power uprates. The historical uprates relied mostly on the already available safety margins to demonstrate plant modifications due to power uprates do not affect the overall plant safety. For most plants, the remaining safety margins, as currently assessed, are not large-enough to support additional power uprates on the scale larger than few percent. However, latest developments and advancements in computational resources and technologies, including modern data analytics

technologies such as artificial intelligence and machine learning, allow to dramatically improve modeling and simulations of plant operations and underlying physics-based processes. This results in a much better understanding and representation of scenarios that may occur at an NPP. The advanced, more detailed modeling and simulations of NPP scenarios remove unnecessary conservatisms typically imbedded in most of the analyses and demonstrate improved, i.e., larger, safety margins directly supporting larger power uprates. This scoping study is discussed in detail in Appendix D.

A technical basis was reviewed for using higher enriched (e.g., up to 10 wt%) FeCrAl and Cr-coated Zr ATF. Safety analysis approaches are outlined and a plan for fuel performance and source term analyses is presented. In the study, an AI-based fuel assembly and core designing optimization method is proposed to maximize benefits from power uprate considering design and safety limitations. A proposed optimized reactor core will be used as reactor data to simulate normal plant operation as well as accident scenarios, anticipated operational occurrences, and design basis accident simulations will be used to confirm adequate safety margins. Table 16 shows the requirements for normal operating conditions (NOO). For transient accident scenarios, current regulatory limits such as power and hot channel peaking factors, boron concentration, departure of nucleate boiling rate, peak cladding temperature, and source terms will be applied. However, new limits and success criteria could be proposed since ATFs have shown enhanced resiliency in accidental situations.

Table 16. List and requirements for normal operation

List of Events	Event Requirements Detail
Steady-state and shutdown operations	<ul style="list-style-type: none"> a. Power operation (>5%–100% of rated thermal power) b. Startup ($K_{eff} \geq 0.99$, ≤ 5 percent of rated thermal power) c. Hot standby (subcritical, residual heat removal system [RHRS] isolated) d. Hot shutdown (subcritical, RHRS in operation) e. Cold shutdown (subcritical, RHRS in operation) f. Refueling
Operation with permissible deviations	<ul style="list-style-type: none"> a. Operation with components or systems out of service b. Leakage from fuel with clad defects c. Radioactivity in the reactor coolant <ul style="list-style-type: none"> 1) Fission products 2) Corrosion products 3) Tritium d. Operation with steam generator leaks up to the maximum allowed by the <ul style="list-style-type: none"> 1) Technical specifications 2) Testing as allowed by the technical specifications

7. SUMMARY

With the passage of the IRA in 2022, existing nuclear utilities are faced with an option not only to uprate their existing NPPs, but also to consider hydrogen cogeneration. This unique opportunity requires a further understanding of whether power uprates are viable options. The findings of this report suggest that substantial untapped power exists in the U.S. BWR and PWR fleet. A follow-on question to this is if the newly added power should be sold to the to the grid, or instead be used for hydrogen cogeneration.

Modeling performed by this project addresses this question and points to a potential range in which hydrogen co-generation is the most profitable option for a NPP. Additionally, the modeling helps to answer other questions such as how a utility should determine if a PTC should be elected over an ITC, how remaining plant life impacts profitability, how much of the added energy should be diverted to the HTSE system, and how competitive clean hydrogen is with natural gas-based hydrogen. Generally, one could conclude from the results

that there are very realistic scenarios where hydrogen cogeneration could produce a higher return. It is also clear that electing to use tax credits for either hydrogen production or electricity production will increase returns. Obviously, this comes with nuances, and the modeling shows that specific nuclear utilities should be deliberate in their decision to elect either ITC or PTC. It also shows that utilities should have a picture of what they expect power and natural gas prices to be in the future to truly understand what kind of returns to expect. It should also be recalled that this modeling does not account for storage or transportation which could have larger implications for cost and profitability.

With the potential profitability of these opportunities in mind, utilities must also consider the location specific variables to determine what action to take. In the case of producing hydrogen, it is vital to understand if local demand exists in high enough quantities to warrant building a given sized HTSE plant. A given utility must identify where demand may exist in the future, and if the targeted uprate will meet or exceed that amount. Rightsizing plants to match demand and understanding the required prices to sell into a given market could have major implications for the profitability of clean hydrogen production. Despite this, with the continued adoption of clean hydrogen in new industries and the advancement of hydrogen hubs it is likely hydrogen demand will continue to grow outside its current production centers. This ultimately should prove positive for NPPs considering uprating with hydrogen co-generation in the future.

Leveraging IRA tax credits means that uprating now is more profitable than in past decades. Whether this is used to produce electricity or hydrogen is a factor of multiple variables. However, regardless of what added power is used for, it is certain the added capacity will play a vital role in long-term U.S. decarbonization. The potential addition or replacement of carbon intensive electricity and/or hydrogen will help to reduce global CO₂ emissions and highlight the vital role existing NPPs can play in reaching climate targets as fast as possible. Ultimately, IRA tax credits help nuclear utilities by creating an unprecedented opportunity to increase and diversify their revenue while also propelling the U.S. toward a low carbon energy future.

8. REFERENCES

- [1] 117th Congress. 2021-2022. *H.R.5376 – Inflation Reduction Act of 2022*. Accessed April 27, 2023. <https://www.congress.gov/bill/117th-congress/house-bill/5376>.
- [2] NEI. 2009. “Roadmap for Power Uprate Program Development and Implementation.” Nuclear Energy Institute, NEI 08-10, rev 0. <https://www.nrc.gov/docs/ML0925/ML092540581.pdf>.
- [3] IAEA Nuclear Energy Series. 2011. “Power Uprates in Nuclear Power Plants: Guidelines and Experience.” International Atomic Energy Agency, No. NP-T-3.9. https://www-pub.iaea.org/MTCD/Publications/PDF/Pub1484_web.pdf.
- [4] NRR. 2003. “Review Standard for Extended Power Uprates.” Nuclear Reactor Regulation, U.S. Nuclear Regulatory Commission, RS-001, rev 0. <https://www.nrc.gov/reactors/operating/licensing/power-uprates/rs-001-rev-0-dec2003.pdf>.
- [5] GEH. 2008. “Safety Analysis Report for Monticello Constant Pressure Power Uprate.” General Electric Hitachi Nuclear Energy, NEO-333222, rev 3. (NRC ADAMS Accession No. ML083230112).
- [6] W.-C. Cheng, L. T. Knighton, L. Larsen, P. Talbot and R. Boardman, “Estimating the Value of Nuclear Integrated Hydrogen Production and the Dependency of Electricity and Hydrogen Markets on Natural Gas,” INL/PRT-23-73909, 2023.
- [7] Rund, J. 2023. “RE: INL/MPR/NEI Uprate Report & NEI IRA Write-up 8-17-23.docx.” Email.
- [8] IRS. 2022. “Prevailing Wage and Apprenticeship Initial Guidance Under Section 45(b)(6)(B)(ii) and Other Substantially Similar Provisions.” Internal Revenue Service, 2022-26108. <https://www.federalregister.gov/documents/2022/11/30/2022-26108/prevailing-wage-and-apprenticeship-initial-guidance-under-section-45b6bii-and-other-substantially>.
- [9] U.S. DOE Presentation. 2022. “Overview of DOE Requests for Information Supporting Hydrogen Bipartisan Infrastructure Law Provisions, Environmental Justice, and Workforce Priorities.” U.S. Department of Energy. <https://www.energy.gov/sites/default/files/2022-02/h2iqhour-02242022.pdf>.
- [10] U.S. NRC. n.d. “Approved Applications for Power Uprates.” U.S. Nuclear Regulatory Commission. Accessed April 4, 2023. <https://www.nrc.gov/reactors/operating/licensing/power-uprates/status-power-apps/approved-applications.html>.
- [11] GE. 1999. “Generic Guidelines for General Electric Boiling Water Reactor Extended Power Uprate.” General Electric, NEDC-32424P-A, Class III (GE Proprietary Information – NP versions available), (ELTR 1).
- [12] U.S. DOE. 2020. “Hydrogen Strategy: Enabling a Low-Carbon Economy.” U.S. Department of Energy, Accessed April 5, 2023. https://www.energy.gov/sites/prod/files/2020/07/f76/USDOE_FE_Hydrogen_Strategy_July2020.pdf
- [13] Koch Blank, T. and Molly, P. 2022. “Hydrogen’s Decarbonization Impact for Industry: Near-term challenges and long-term potential.” Rocky Mountain Institute. Accessed April 6, 2023. https://rmi.org/wp-content/uploads/2020/01/hydrogen_insight_brief.pdf.
- [14] U.S. DOE. “Hydrogen Shot.” U.S. Department of Energy. Accessed April 5, 2023. <https://www.energy.gov/eere/fuelcells/hydrogen-shot>.
- [15] EPRI. 2019. “Program on Technology Innovation: Prospects for Large-Scale Production of Hydrogen by Water Electrolysis.” Electric Power Research Institute, Technical Update 3002014766. <https://restservice.epri.com/publicdownload/000000003002014766/0/Product>.
- [16] U.S. DOE. “LWR Integrated Energy Systems Interface Technology Development & Demonstration.” Accessed April 6, 2023. U.S. Department of Energy, Office of Nuclear Energy.

https://www.energy.gov/sites/prod/files/2020/10/f79/IND%20FOA%20FY20_%20Summary-Abstract%20ARD-20-22098%20Northern%20States%20Power.pdf.

- [17] Hughlett, M. 2021. “Xcel looking at clean-energy hydrogen projects,” *Star Tribune*, Accessed April 6, 2023. <https://www.startribune.com/xcels-flat-earnings-fall-short-of-expectations/600110785/>.
- [18] WNN. 2021. “Nine Mile Point to produce hydrogen for self-supply.” World Nuclear News. Accessed April 6, 2023. <https://www.world-nuclear-news.org/Articles/Nine-Mile-Point-to-produce-hydrogen-for-self-suppl#:~:text=A%20containerised%20Proton%20Exchange%20Membrane,a%20hydrogen%20production%20demonstration%20project>.
- [19] Fuel Cells Bulletin. 2020. “Road map to a US hydrogen economy.” Fuel Cells Bulletin, **vol 2020**, no. 11, 12. Accessed August 30, 2023. [https://doi.org/10.1016/S1464-2859\(20\)30532-0](https://doi.org/10.1016/S1464-2859(20)30532-0).
- [20] IEA. 2022. “Global demand for pure hydrogen, 1975-2018.” International Energy Agency. Accessed April 6, 2023. <https://www.iea.org/data-and-statistics/charts/global-demand-for-pure-hydrogen-1975-2018>.
- [21] IEA. 2022. “Global Hydrogen Review 2022.” International Energy Agency. Accessed April 12, 2023. <https://iea.blob.core.windows.net/assets/c5bc75b1-9e4d-460d-9056-6e8e626a11c4/GlobalHydrogenReview2022.pdf>.
- [22] Ruth, M.F., et al. 2020. “The Technical and Economic Potential of the H2@Scale Concept within the United States.” National Renewable Energy Laboratory, NREL/TP-6A20-77610. <https://doi.org/10.2172/1677471>.
- [23] Knighton, L. T., et al. 2020. “Scale and Regionality of Nonelectric Markets for U.S. Nuclear Light Water Reactors.” Idaho National Laboratories, INL/EXT-20-57885. <https://doi.org/10.2172/1615670>.
- [24] U.S. DOE. n.d. “Regional Clean Hydrogen Hubs.” U.S. Department of Energy, Office of Clean Energy Demonstrations. Accessed April 6, 2023. <https://www.energy.gov/oced/regional-clean-hydrogen-hubs>.
- [25] Bioret, L., Zhu, Y., and Krupnik, A. 2023. “Hydrogen Hubs: Get to Know the Encouraged Applicants.” Resources. Accessed April 6, 2023. <https://www.resources.org/common-resources/hydrogen-hubs-get-to-know-the-encouraged-applicants/>.
- [26] IEA. 2022. “Electrolysers: Technology deep dive.” International Energy Agency. Accessed April 12, 2023. <https://www.iea.org/reports/electrolysers>.
- [27] Straits Research. n.d. “Electrolyzer Market: Information by Product (Alkaline Electrolyzer, PEM Electrolyzer), Capacity (Less than 500 kW), Application (Power Generation), and Region – Forecast til 2030.” Accessed April 6, 2023. <https://straitsresearch.com/report/electrolyzer-market>.
- [28] Burleson, E. 2022. “Private investment in hydrogen breaks record.” *Pitchbook*. Accessed August 30, 2023. <https://pitchbook.com/news/articles/hydrogen-energy-transition-deals-record-pe-vc-2022>.
- [29] F. E. Saba, 2017. “Browns Ferry Nuclear Plant, Units 1, 2, and 3 – Issuances of Amendments Regarding Extended Power Uprate (CAC Nos. MF6741, MF6742, and MF6743). (NRC ADAMS Accession No.: ML17032A120).” Letter.
- [30] GEH. 2012. “Safety Analysis Report for Exelon Peach Bottom Atomic Power Stations Units 2 and 3 Constant Pressure Power Uprate (Non-Proprietary).” General Electric Hitachi Nuclear Energy, NEDO-33566, rev 0, (NRC ADAMS Accession No.: ML12286A011). <https://www.nrc.gov/docs/ML1228/ML12286A013.pdf>.
- [31] Ennis R. 2014. “Peach Bottom Atomic Power Station, Units 2 and 3 – Issuance of Amendments Re: Extended Power Uprate (TAC Nos. ME9631 and ME9632).” Letter. (NRC ADAMS Accession No.: ML14133A046).

- [32] GEH. 2008. “Safety Analysis Report for Monticello Constant Pressure Power Uprate.” General Electric Hitachi Nuclear Energy, NEO-333222, rev 3. (NRC ADAMS Accession No. ML083230112).
- [33] GEH. 2010. “Safety Analysis Report for Grand Gulf Nuclear Station Constant Pressure Power Uprate (Non-Proprietary).” General Electric Hitachi Nuclear Energy, NEDO-33477, rev 0. (NRC ADAMS Accession No.: ML102660399). <https://www.nrc.gov/docs/ML1026/ML102660399.pdf>.
- [34] Wang, A. 2012. “Grand Gulf Nuclear Station, Unit 1 – Issuance of Amendment Re: Extended Power Uprate (TAC No. ME4679).” Letter. (NRC ADAMS Accession No.: ML121210020).
- [35] U.S. NRC. 2009. “Point Beach Nuclear Plant, Units 1 and 2 Extended Power Uprate Licensing Report, Attachment 5.” U. S. Nuclear Regulatory Commission, Point Beach Nuclear Plant. (NRC ADAMS Accession No.: ML091250566).
- [36] U.S. NRC. 2010. “Turkey Point, Units 3 and 4 Extended Power Uprate Licensing Report. Attachment 4, Appendix C.” U. S. Nuclear Regulatory Commission, Turkey Point, 50-250 and 50-251. (NRC ADAMS Accession No.: ML103560177). <https://www.nrc.gov/docs/ML1035/ML103560180.pdf>.
- [37] U.S. NRC. 2011. “St. Lucie Nuclear Plant, Unit 2 Extended Power Uprate Licensing Report. Attachment 5, Appendix D.” U.S. Nuclear Regulatory Commission, St. Lucie Nuclear Plant, 50-389. (NRC ADAMS Accession No.: ML110730299). <https://www.nrc.gov/docs/ML1107/ML110730304.pdf>.
- [38] Flessner, D. 2018. “TVA Boosting Power Output at Browns Ferry With \$475 Million Upgrade.” *Chattanooga Times Free Press*. Accessed April 4, 2023. <https://www.timesfreepress.com/news/2018/feb/20/tva-boosts-power-output/>.
- [39] O’Connor, T. J. 2013. “In the Matter of a Commission Investigation into Xcel Energy’s Monticello Life Cycle Management/Extended Power Uprate Project and Request for Recovery of Cost Overruns.” Testimony. Minnesota Public Utilities Commission. Docket No. E002/CI-13-754.
- [40] W.-C. Cheng, L. T. Knighton, L. Larsen, P. Talbot and R. Boardman, “Estimating the Value of Nuclear Integrated Hydrogen Production and the Dependency of Electricity and Hydrogen Markets on Natural Gas,” INL/PRT-23-73909, 2023.
- [41] Staff Reports. 2012. “Grand Gulf Upgrade Costs Jump 34 Percent.” *The Vicksburg Post*. Accessed April 4, 2023. <https://www.vicksburgpost.com/2012/05/11/grand-gulf-upgrade-costs-jump-34-percent/>.
- [42] NEI. 2022. “Nuclear Costs in Context.” Nuclear Energy Institute. <https://www.nei.org/resources/reports-briefs/nuclear-costs-in-context>.
- [43] Saefong, M. P. 2022. “Why Russia’s invasion of Ukraine lifted uranium prices to their highest in over a decade.” *MarketWatch*. <https://www.marketwatch.com/story/why-russias-invasion-of-ukraine-lifted-uranium-prices-to-their-highest-in-over-a-decade-11647537166>.
- [44] WNA. n.d. “Economics of Nuclear Power.” World Nuclear Association. (Last Updated August 2022). <https://www.world-nuclear.org/information-library/economic-aspects/economics-of-nuclear-power.aspx>.
- [45] IEA. 2020. “Projected Costs of Generating Electricity.” License CC BY 4.0. <https://www.iea.org/reports/projected-costs-of-generating-electricity-2020>.
- [46] NEI. 2023. “Safety and Economic Benefits of Accident Tolerant Fuel, Revision 1.” NEI 19-01, Nuclear Energy Institute.
- [47] B. Durham, F. Franceschini, H. Lam, and C. Wagener. 2022, “Levelized Cost of Electricity Evaluations for Westinghouse Advanced Fuel Management with High Enrichment and High Burnup Fuel to Optimize PWR Economics.” Proc. in the TopFuel 2022 Light Water Reactor Fuel Performance Conference, Raleigh, NC: Oct. 9–13, 2022. <https://www.ans.org/pubs/proceedings/issue-3218/>.

APPENDIX A

Model Sheets and Case Study Inputs

A-1. MODEL SHEETS

The model uses several sheets to generate this cashflow analysis. A summary of each sheet is provided below.

A-1.1 Results Summary and Inputs Sheet

The “Results Summary & Inputs” sheet consists of a summary of results table that provides key output metrics and multiple input tables that make up the power uprate and hydrogen cogeneration inputs. Each of these tables has detailed notes in the Microsoft™ Excel sheet to guide the user on what each of the inputs is (see model for additional details).

The IRA tax credits are discussed in the “Key Financial Inputs Table.” As discussed in Section 3.1, the values of these tax credits are dependent on a series of additional requirements involving wage and apprenticeship, energy community, and domestic content. These requirements are input into the model through the user inputs.

A-2. ESCALATION INPUTS SHEET

The “Escalation Inputs” sheet allows the user to define historical and future escalation rates for nine model inputs:

- Uprate construction
- H₂ construction
- H₂ net sale price
- Uprate operational expenditures (OPEX – also referred to as O&M)
- H₂ OPEX
- Fuel
- Power PTC
- H₂ PTC
- Power pricing.

There are multiple options the user can select to define the escalation rates:

- Sample values are provided that use historical rates from producer price indices (PPIs) for 2019–2022 and then a 3–4 year trailing average for 2023 and 2024. 2025 and beyond assume a standard escalation rate of 2.5% for all inputs. The sample PPIs used are from the FRED and are summarized in Table A-1 [1][2][3][4][5][6]. Note the GDP implicit price deflator was chosen for fuel prices as most utilities employ long-term procurement strategies that reduce their exposure to short-term market fluctuations. The user can adjust this value accordingly using an alternative option discussed below. Similarly, power pricing is dependent on a number of factors such as any power purchases agreements, capacity payments, and regional

grid resources. Thus, it is important for the user to be able to choose and modify future power pricing as they best see fit. The base case herein utilizes the GDP implicit price deflator for simplicity.

Table A-1. Sample escalation rate basis.

Parameter	PPI
Uprate Construction	New Industrial Building Construction
H ₂ Construction	Chemical Engineering Plant Cost Index
H ₂ Net Sale Price	Gross Domestic Product: Implicit Price Deflator
Uprate OPEX	Maintenance & Repair Services for Industrial Machinery
H ₂ OPEX	Maintenance & Repair Services for Industrial Machinery
Fuel	GDP: Implicit Price Deflator
Power PTC	GDP: Implicit Price Deflator
H ₂ PTC	GDP: Implicit Price Deflator
Power Pricing	GDP: Implicit Price Deflator

- Alternatively, the user may utilize the “Overwrite to Single Input?” toggle to simplify this escalation for each of the nine inputs into one constant value prior to power uprate and hydrogen cogeneration implementation “Pre-COD Inflation” and one constant value after power uprate and hydrogen cogeneration implementation “Post-COD Inflation.”
- Finally, the user may manually edit yearly inflation values for all nine inputs from 2020 to 2090.

This sheet also contains the data used to construct the project spend curves. Generic spend curves are provided for flat, bell, ramped, triangle, and linear spend rates. Alternatively, the user may define a specific project spend curve if known for their specific uprate project. Both the spend curve [probability distribution function (PDF)] and the cumulative spend [cumulative distribution function] are provided. An example of the triangular spend curve is shown in Figure A-1.

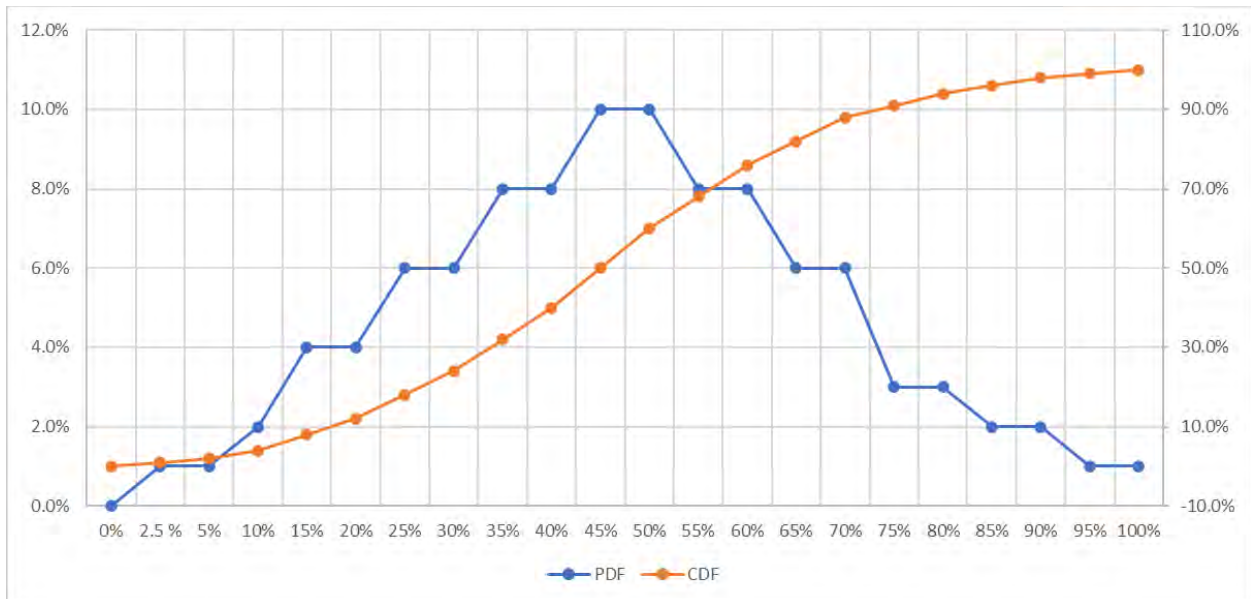

Figure A-1. Example project spend curve.

A-2.1 Sensitivities Sheet

The “Sensitivities” sheet allows the user to visualize the effect of a number of key inputs on project outputs as summarized in Table A-2. Note the user may need to select “Calculate Now” in the “Formulas” tab of Microsoft™ Excel. Data tables and figures are iterative calculations and may take some time to update.

Table A-2. Model sensitivities.

Scenario	Input(s)	Output
Uprate Only	Overnight Capital Costs/MWe vs IRA	LCOE
	Overnight Capital Costs/MWe vs IRA	Project IRR
	Overnight Capital Costs/MWe vs Power Price	Equity IRR
	Overnight Capital Cost/MWe vs Return on Debt	LCOE
	Overnight Capital Cost/MWe vs Remaining Plant Life after Uprate	LCOE
	Uprate Construction Escalation vs IRA	Equity IRR
Uprate + Hydrogen Cogeneration	Percent Uprate to H ₂ vs. H ₂ Facility Type	Equity IRR
	Percent Uprate to H ₂ vs H ₂ Sales Price	Equity IRR
	Natural Gas Price vs H ₂ Generation Types	LCOH
	Power Price vs. H ₂ Sales Price	Equity IRR

A-3. CASE STUDY INPUTS

This section provides the inputs used to generate the results discussed in Section 5.3.

Table A-3. Case study key project inputs.

Uprates	Value	Units
Uprate Overnight CAPEX	500,000	\$000s
Uprate Overnight CAPEX Basis Year	2023	[year]
Uprate Overnight CAPEX per MWe	100	\$000s / MWe
Electrical Capacity Added	5,000	Mwe
Remaining Plant Life as of 1/1/23	40	Years
Project Start Date (start of spend)	1/1/2025	[mm/01/yyyy]
Construction Start Date (1st construction outage)	3/1/2028	[mm/01/yyyy]
Number of Outages for Construction	2	Outages
Additional Days Offline for Each Construction Outage		
Outage 1	5	Days
Outage 2	5	Days
Outage 3	N/A	Days
Outage 4	N/A	Days
Construction End Date / COD	10/31/2029	[mm/dd/yyyy]
Project Duration	4.83	Years
Remaining Plant Life at COD	33.17	Years
Project Spend Profile	Triangle	Curve

Uprates	Value	Units
H ₂ Facility	Value	Units
Uprate Capacity Used for H ₂	100%	%
Natural Gas Price	6	\$/MMBTU
Average H ₂ Sale Price	2.29	\$/kg

Table A-4. Case study key financial inputs.

Financials	Value	Units
Results Basis Year	2023	[year]
Average Power Price	40.00	\$/MWh
% Equity Finance	50.0%	%
Target Post-Tax Return on Equity	10.00%	%
% Debt Finance	50.0%	%
Debt Repayment Term	30	years
Return on Debt	5.00%	%
Effective Tax Rate	23.5%	%
Post-Tax WACC	6.91%	%
IRA Tax Credits	Value	Units
IRA—Prevailing Wage & Apprenticeship Requirements Met?	Yes	[yes/no]
IRA—Project in Energy Community?	No	[yes/no]
IRA—Domestic Content Requirement Met (or exemption granted)?	Yes	[yes/no]
IRA—Use Direct Payment Option?	No	[yes/no]
Direct Payment Reduction	0	%
Tax-Exempt Financing Reduction—% of Costs Financed with Tax-Exempt Bonds	0	%
PTC Market Haircut (% lost)	0%	%
ITC Market Haircut (% lost)	0%	%
ITC Cost Basis Reduction (% removed)	0%	%

Table A-5. Case study other inputs—uprate project.

Uprate Project	Value	Units
Generation / Outputs		
Plant Thermal Efficiency	33%	%
Thermal Capacity Added	303	MW-th
Standard Fuel Cycle Length	18	Months
Standard Refueling Outage Duration	26	Days
Estimated Generation Loss (not due to refueling)	1%	%
Capacity Factor	94.30%	%
Initial Plant Capacity	1,200	MWe
OPEX & Fuel		
Uprate Change in OPEX	—	\$000/year
Uprate OPEX Basis Year	2022	[year]
Fuel Cost for Uprate Output	0.0055	\$000/MWh
Fuel Cost Basis Year	2023	[year]
Depreciation		
Depreciable Basis Reduction	0%	%
Depreciation Life	15	years
Declining Balance Factor	150%	%
IRA Tax Credits		
Base Power PTC Value (IRA 45Y)	5.72	\$/MWh
Power PTC Value Basis Year	2022	[year]
Net Power PTC Value	31.47	\$/MWh
Power PTC Duration	10	years
Base ITC % (IRA 45E)	6%	%
Net ITC%	40%	%
Base H ₂ PTC Value (45V)	0.60	\$/kg
Net H ₂ PTC Value	3.00	\$/kg
H ₂ PTC Value Basis Year	2022	[year]
H ₂ PTC Duration	10	Years

Table A-6. Case Study—Other Inputs—H₂ Facility.

H ₂ Facility	LTE Value	HTE Value	Units
H₂ Generation			
Nuclear Plant Efficiency Reduction (HTE only)	N/A	0.0%	%
Reduced Nuclear Plant Efficiency (HTE only)	N/A	33.0%	%
Max Electrical Capacity to H ₂ (HTE only)	N/A	94.57%	%
Power to H ₂ (AC)	100.00	94.57	MW-AC
AC-DC Converter Rating	0.91	0.93	MW-DC/MW-AC
Power to H ₂ (DC)	90.8	87.8	MW-DC
Electrical Power Consumption Rate (DC)	50.4	34.17	kWh-DC/kg
Thermal Power Consumption Rate	N/A	6.40	kWh-th/kg
Design H ₂ Production Rate	43,243	61,683	kg/day
H ₂ Facility Degradation	100%	96.6%	%
Gross Annualized H ₂ Production	14,894,595	20,517,825	kg/year
H ₂ Loss to Distribute (% lost)	0%	0%	%
Project Costs			
Overnight CAPEX Basis Year	2020	2020	[year]
Overnight CAPEX per MW-DC Input	828.78	1,285.9	\$000s/MW-DC
H ₂ Tie-In Costs	1%	1%	% of CAPEX
H ₂ Overnight CAPEX	76,015	114,058	\$000s
OPEX			
H ₂ OPEX Basis Year	2020	2020	[year]
Process Water Costs	123	106	\$000/year
Cooling Water Costs	N/A	17	\$000/year
Annual Labor + G&A Cost	1,338	1,263	\$000/year
Property Tax & Insurance	2.0%	2.0%	% of CAPEX
Production Maintenance & Repairs	2.1%	2.1%	% of CAPEX
Average Annual Stack Replacement (planned)	1.5%	2.3%	% of CAPEX
Average Annual Stack Replacement (unplanned)	0.5%	0.5%	% of CAPEX
Total OPEX	6,084	9,303	\$000/year
Depreciation			
Depreciable Basis Reduction	0.7%	0.7%	%
Depreciable Life	20	20	Years
Declining Balance Factor	150%	150%	%

A-4. APPENDIX A REFERENCES

- [1] FRED. 2023. “Producer Price Index by Industry: New Industrial Building Construction.” PCU236211236211, updated June 14, 2023. <https://fred.stlouisfed.org/series/PCU236211236211#>.
- [2] FRED. 2023. “Producer Price Index by Industry: Electric Power Generation: Utilities.” PCU2211102211104, updated June 14, 2023. <https://fred.stlouisfed.org/series/PCU2211102211104>.
- [3] FRED. 2023. “Producer Price Index by Industry: Industrial Gas Manufacturing: Argon and Hydrogen.” PCU325120325120C, updated June 14, 2023, <https://fred.stlouisfed.org/series/PCU325120325120C>.
- [4] FRED. 2023. “Producer Price Index by Industry: Commercial Machinery Repair and Maintenance: Maintenance and Repair Services for Industrial Machinery.” PCU8113108113107, updated June 14, 2023. <https://fred.stlouisfed.org/series/PCU8113108113107>.
- [5] FRED. 2023. “Global price of Uranium.” PURANUSDM, updated June 14, 2023. <https://fred.stlouisfed.org/series/PURANUSDM>.
- [6] FRED. 2023. “Gross Domestic Product: Implicit Price Deflator.” GDPDEF, updated May 25, 2023. <https://fred.stlouisfed.org/series/GDPDEF>

APPENDIX B

Hydrogen Cogeneration

B-1. LOW-TEMPERATURE ELECTROLYSIS

LTE is an electrochemical process that uses electrical power to split water into hydrogen and oxygen and generally operates at low temperatures of 20–100°C and generally does not require a heat addition from an external energy source. Low-temperature operation simplifies the LTE process configuration as no additional equipment is needed to provide process heat input.

When LTE technology is considered in nuclear hydrogen production scenarios, no heat transfer from the NPP to the LTE process is required. This analysis considers use of LTE technology for BWR NPP cases since BWRs do not incorporate isolation of the reactor coolant and the steam Rankine cycle working fluid, which could introduce pathways for an inadvertent dispersion of radioactive materials in a hypothetical process heat application.

Two established LTE technologies are alkaline electrolysis (AE) and proton exchange membrane (PEM) electrolysis. AE is the incumbent water electrolysis technology and is widely used for large-scale industrial applications since 1920. AE systems are readily available and durable and exhibit relatively low capital cost due to the avoidance of noble metals and relatively mature stack components. [1] PEM systems are based on the solid polymer electrolyte concept for water electrolysis introduced by GE in the 1960s. Key advantages of PEM electrolysis are high power density and cell efficiency, provision of highly compressed and pure hydrogen, and flexible operation. [1]–[3] Figure B-1 indicates that PEM energy consumption is lower than AE for proven cases and is also expected to be lower than AE energy consumption in advanced technology scenarios.

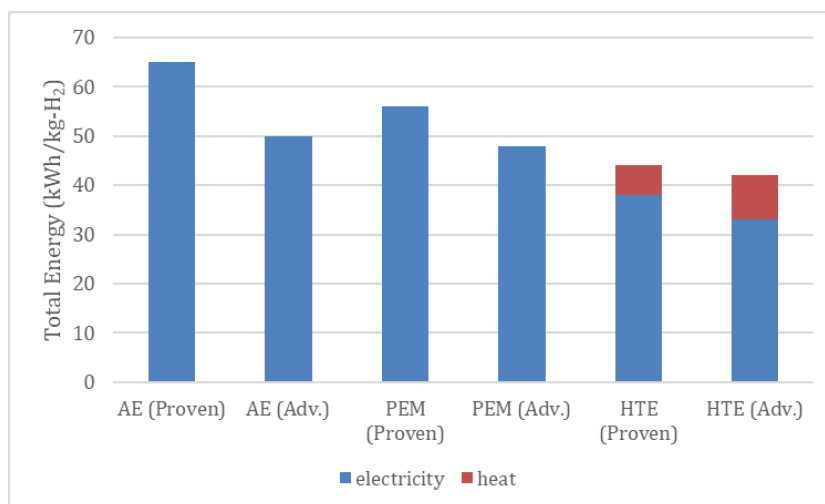

Figure B-1. Comparison of electrical and heat duties for proven and advanced electrolysis options. [4]

PEM disadvantages relative to AE include expensive platinum catalyst and fluorinated membrane materials, higher system complexity due to HP operation and water purity requirements, and shorter stack lifetime than AE. [1], [2] As PEM technology continues to advance, it is expected that stack life will increase and capital costs will decrease. Recent selection of PEM technology by industrial companies such as Shell and Linde for green hydrogen production projects [5] suggest that PEM technology deployment will continue to increase in the coming years.

PEM technology was selected as the basis for LTE hydrogen production in this analysis due to the energy efficiency, increased capability for HP hydrogen production, flexible operating characteristics, and recent increases in PEM technology deployment.

B-1.1 PEM Operating Principles

PEM water electrolysis requires introducing liquid water to the anode where it is split into oxygen (O₂), protons (H⁺), and electrons (e⁻). The protons travel through the proton-conducting membrane to the cathode side. The electrons exit the anode through the external power circuit, which provides the driving force (cell voltage) for the reaction. The protons and electrons recombine on the cathode side to produce hydrogen. [3] A schematic of the PEM electrolysis cell construction is shown in Figure B-2. The electrochemical reactions that occur in the anode and cathode of a PEM electrolysis cell are provided in Equations (1) and (2), respectively. The overall solid oxide electrolysis cells (SOEC) reaction is provided in Equation (3). [3]

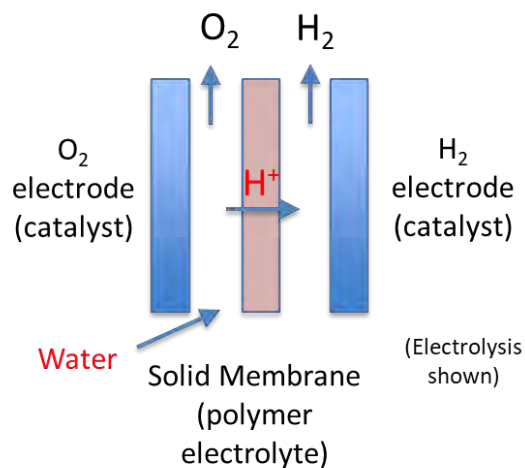
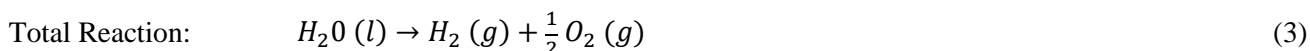
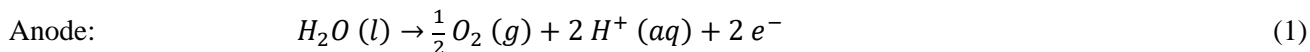

Figure B-2. PEM electrochemical cell configuration. [6]



B-1.1.1 Technology Readiness Levels / Deployment Schedule

PEM is commercially available technology. There has been an increase in new electrolysis installations over the past decade, with PEM technology accounting for a significant number of these installations. Additionally, the average size of electrolyzer installations has increased from 0.1 to 1.0 MWe small pilot and demonstration projects to 10 MWe and larger commercial scale projects [7]. Three nuclear powered LTE/PEM demonstration projects are in progress. The Constellation Nine Mile Point 1 MW demonstration began operating in March 2023. The Energy Harbor Davis-Besse ~1-2 MWe demonstration and the APS/Pinnacle West Hydrogen ~15-20 MW demonstrations could start hydrogen production operations in 2023/2024. In early 2023, ITM Power announced that contracts had been signed with Linde Engineering for sale of two 100 MWe PEM electrolyzer units to be installed in Germany [8].

There are multiple manufacturers of PEM stacks and systems. An alphabetical list of prominent PEM manufacturers and specifications for selected products from each of these manufacturers is provided in Table B-1.

Table B-1. List of PEM manufacturers and electrolyzer products.

Company Name	Company location	PEM Electrolyzer Model Name	Input power	Production Capacity
Cummins	Columbus, Indiana United States	HyLYZER - 1000	18.3 MW	8,630 kg/day [9]
ITM Power	Sheffield United Kingdom	Poseidon	20 MW [10]	~9,200 kg/day ^a
Nel	Oslo Norway	M-5000	~23 MW ^a	10,618 kg/day [11]
Plug Power	Latham, New York United States	EX-4250D	~9.2 MW ^a	4,250 kg/day [12]
Siemens	Munich Germany	Silyzer 300	17.5 MW [13]	8,040 kg/day [13]

Notes:
^a Calculated based on an assumed system specific energy consumption of 52 kWh/kg

B-1.1.2 Performance and Cost Estimates

Performance and cost estimates for PEM electrolysis technology were adapted from the “Hydrogen Production Cost from PEM Electrolysis – 2019” DOE Hydrogen and Fuel Cells Technology Office (HFTO) Program Record [14] Current Technology Centralized Production case. The HFTO 2019 PEM Program Record is based on a 50,000 kg/day design production capacity system with the stacks oversized to 56,500 kg/day to account for degradation. The balance of plant equipment is sized based on the peak production rate. The average production capacity over the life of the stacks is 50,000 kg/day when accounting for the decrease in output associated with the stack degradation. The capital costs at different capacities are estimated through the use of a 0.9 scaling exponent derived from PEM system capital cost estimates at different system capacities presented by Holst et al. [15] Key performance and cost specifications for a current technology centralized PEM hydrogen production system with an average production capacity of 50,000 kg/day are presented in Table B-2.

Table B-2. PEM system performance and cost specifications.

Parameter	Value
Average Hydrogen Production Rate	50,000 kg/day
Peak Hydrogen Production Rate	56,500 kg/day
System Power Input	130.7 MW-ac
Stack Power Input	118.7 MW-dc
Thermal Energy Input	0 MW-th
Normalized System Electric Power Input	55.5 kWh-ac/kg
Process Water Requirement	214 k-gal/day (Based on specification of 3.8 gal H ₂ O/kg H ₂ from [14])
Hydrogen Product Pressure	20 bar
Direct Capital Costs (DCC)	\$563/kW-dc (2020 USD)
Total Capital Investment (TCI)	\$807/kW-dc (2020 USD)
Fixed O&M Costs	\$45/kWdc-yr (2020 USD)
Variable O&M Costs (excluding energy costs)	\$2.1/MWh-dc (2020 USD)

B-1.2 High-Temperature Electrolysis

HTE is an electrolysis technology that can achieve hydrogen production efficiencies greater than those possible with LTE because of decreases in electrical power demand with increases in cell operating temperature [1],[3],[7],[16]–[18]. Figure B-1 illustrates that the total energy demand of both proven and advanced HTE technology fall below that for AE and PEM. While the decreased electrical power input associated with HTE is partially offset through the requirement for thermal energy input, the total energy costs for HTE can be lower than for LTE especially when a low-cost source of thermal energy is available. HTE is well suited for PWR applications since, in addition to electrical power, the NPP could provide a source of low-cost heat for powering an HTE hydrogen production process.

B-1.2.1 SOEC Operating Principles

This analysis considers HTE via oxide ion-conducting SOECs. A schematic of an SOEC cell is provided in Figure B-3. Steam is introduced to the cathode side of the SOEC stack where it is reduced to hydrogen. Oxide ions travel through the electrolyte to the anode where they recombine into oxygen molecules. The electrochemical reactions that occur in the cathode and anode of an SOEC are provided in Equations (4) and (5). The overall SOEC reaction is provided in Equation (6). [19]

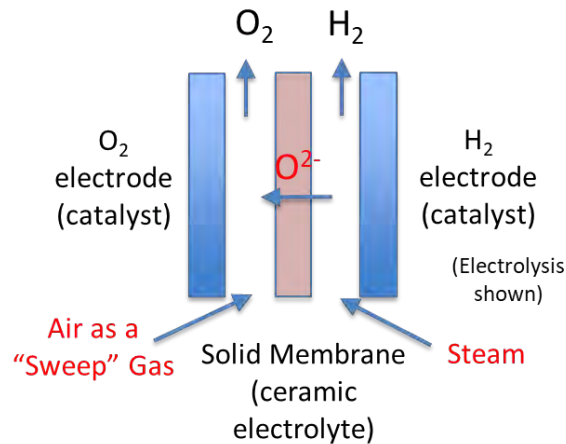
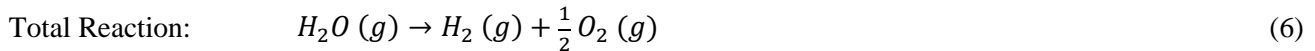
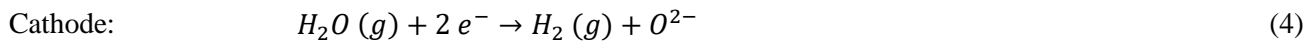

Figure B-3. Solid oxide electrochemical cell configuration.[6]



A simplified HTE process flow diagram is provided in Figure B-4. This figure illustrates the use of external heat input to vaporize the HTE process feedwater, as well as the use of recuperation to superheat the steam input to the stack.

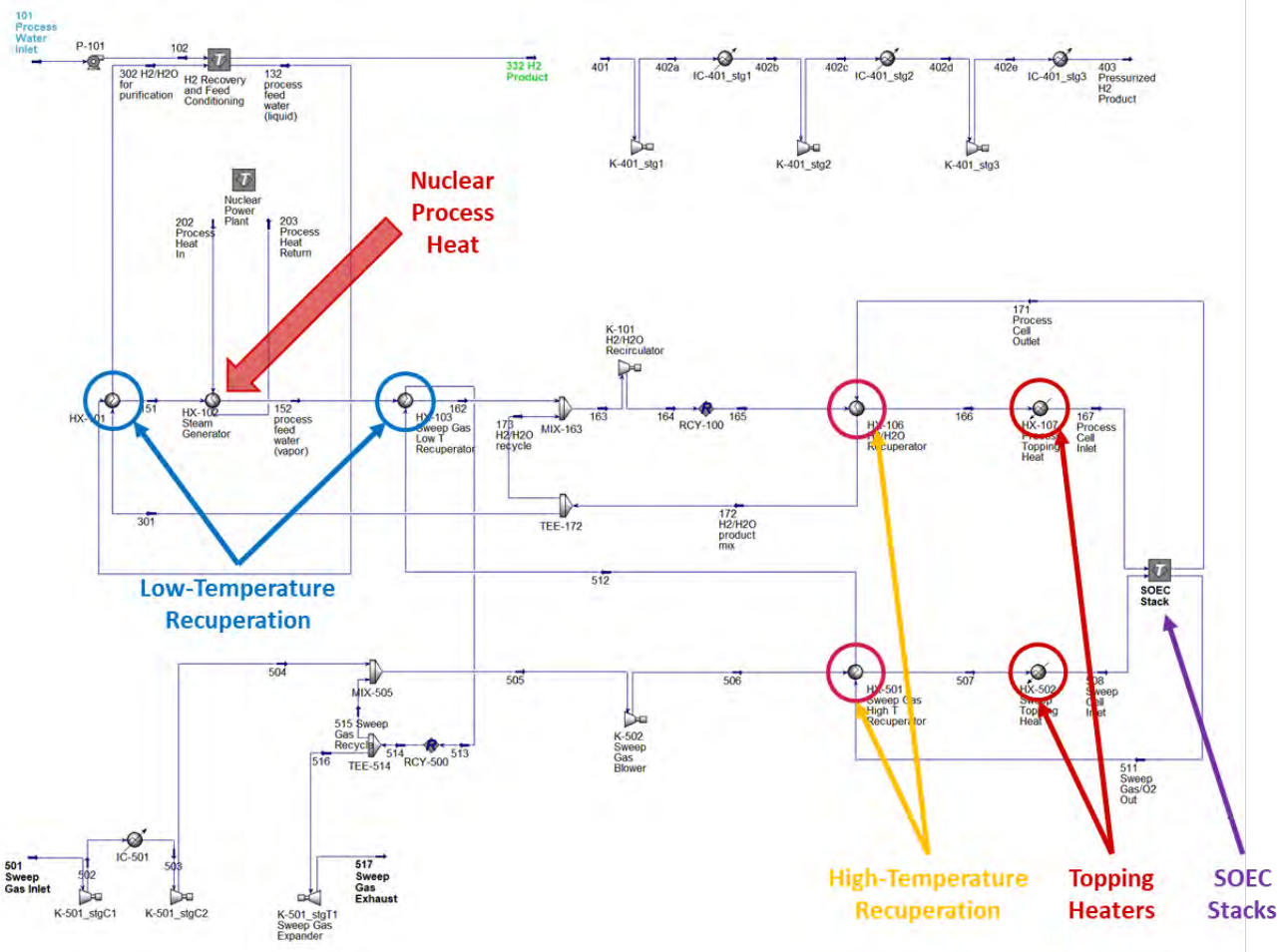

Figure B-4. Simplified HTE process flow diagram.

B-1.2.2 HTE Integration with Nuclear Power Plants

Full electrical and thermal integration of an HTE process with a PWR NPP was considered in this analysis. A PWR NPP uses separate fluid inventories for the reactor coolant (primary loop) and steam Rankine cycle working fluid (secondary loop). Heat from the PWR secondary loop can be sent to the HTE process using a thermal energy delivery loop. The thermal energy delivery loop is a system that transfers heat from the NPP to the HTE site using a tertiary loop filled with heat transfer fluid (HTF) as shown in Figure B-5. Use of different fluid inventories for the reactor coolant, NPP power cycle, thermal energy delivery loop, and HTE process feedwater provides multiple levels of separation between the nuclear reactor and the HTE process and minimizes the possibility of a leak in the primary loop resulting in the inadvertent transfer of radioactive material outside of the NPP boundary.

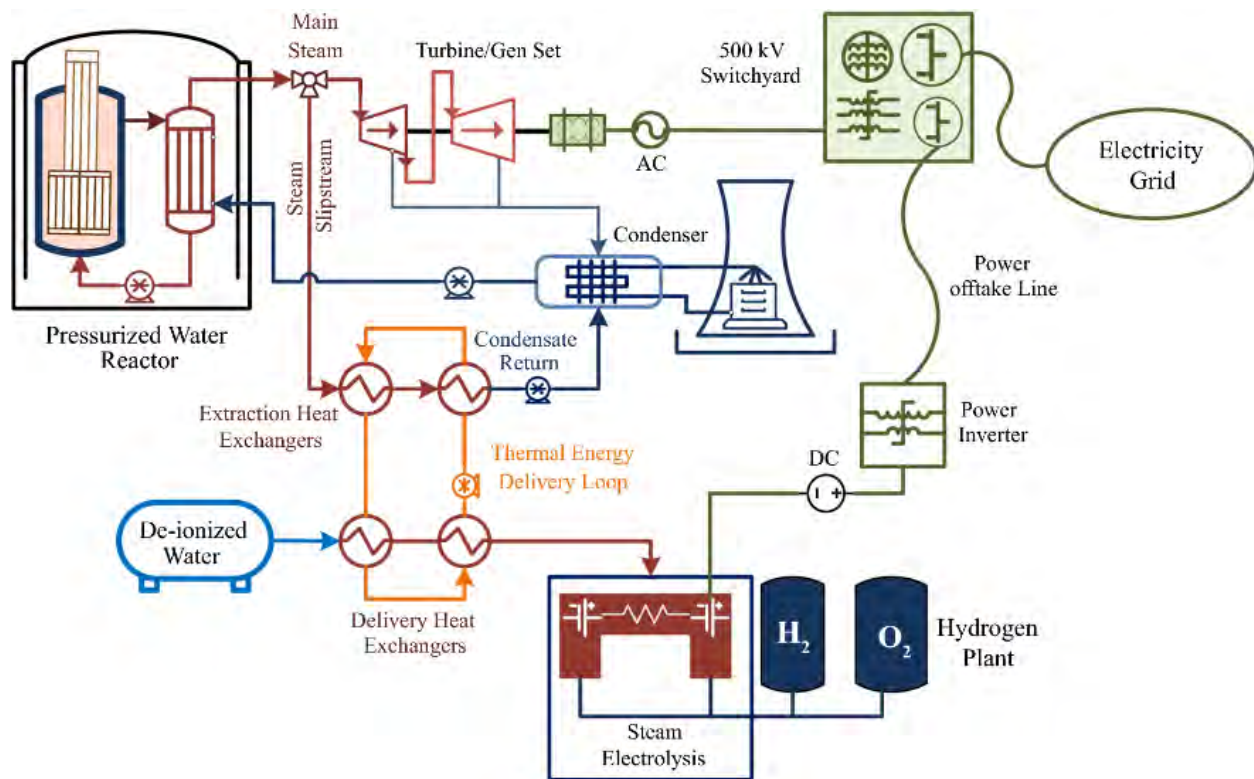

Figure B-5. Heat and electricity delivery from a LWR NPP to a high-temperature SOEC electrolysis plant. [4]

In a BWR, steam generation occurs within the reactor vessel and the same fluid inventory is used to both cool the reactor and drive the power cycle steam turbines. The BWR NPP configuration does not provide as many levels of isolation between the reactor coolant and the HTE process as would be provided by a PWR. Therefore, as previously described, this analysis specified the use of LTE technology for BWR hydrogen production applications to avoid the requirement for BWR process heat export and any associated potential for inadvertent transfer of radioactive material outside of the NPP boundary.

HTE process performance and cost estimates for this analysis were obtained from INL report INL/RPT-22-66117. [20] This HTE process design basis specifies an HTE stack operating temperature of 800°C. LWR NPP reactor outlet temperatures are generally on the order of 300°C. Therefore, an LWR NPP cannot provide heat input directly to the stack. However, the HTE process described in INL/RPT-22-66117 has a significant thermal load for vaporization of HTE process feedwater, which occurs below 300°C, and could be met using heat supplied by a PWR.

The nuclear heat used to vaporize the HTE feedwater is supplied using the previously described thermal energy delivery loop. Thermal energy from the thermal energy delivery loop HTF is used to vaporize the HTE feedwater before the cooled HTF is returned to the NPP. The heat required to raise the stack inlet stream to the specified 800°C stack operating temperature is provided mainly through use of recuperation (heat transfer from the stack outlet streams to the stack inlet streams) as well as through use of electrical topping heaters.

B-1.2.3 Technology Readiness Levels / Deployment Schedule

SOEC technology was developed in the 1970s and has advanced considerably in recent years. SOEC technology was characterized in 2020 as having “medium term” maturity with an estimate of 5–10 years to commercial maturity. [21] As the stack performance and durability has increased, there has been increased focus on testing and demonstration SOEC-based HTE systems, which include the SOEC stacks as well as the balance-of-plant components.

Several tests of SOEC technology integrated with simulated nuclear energy sources are currently in progress or are planned for the near future. These tests include a 100 kW Bloom Energy system tested at INL for over 2,000 hours with plans to accumulate >5,000 hours of system operation by the end of FY23 [22] and a 250 kW Fuel Cell Energy system test scheduled to begin in the near future with the current status including completion of system design, initiation of SOEC module fabrication, completion of balance-of-plant equipment fabrication, and initiation of INL testing site preparation. [23]

A first-of-a-kind demonstration of nuclear-integrated HTE is planned at the Xcel Energy Prairie Island NPP in Minnesota. The demonstration will involve sending steam from the NPP to an unfired boiler, where clean demineralized water will be vaporized and sent to the HTE system. The system will include two 100 kW SOEC units manufactured by Bloom Energy, which will produce about 125 kg of hydrogen per day and are expected to operate for approximately two months. Installation of the HTE skid and plant utility connection is planned for FY 2023, and system startup, hydrogen production operations, and decommissioning and removal of the HTE skid are scheduled for FY 2024. [24]

In addition to the SOEC manufacturers already listed, an alphabetical list of other notable SOEC manufacturers is Bloom Energy, Fuel Cell Energy, Haldor Topsoe, OxEon Energy, and Sunfire.

B-1.2.4 Performance and Cost Estimates

This analysis specifies the use of an SOEC HTE process with electrical and thermal power supplied by a PWR NPP. This configuration is consistent with that described in INL report INL/RPT-22-66117, [20] which provides performance and cost estimates for a gigawatt-scale, nuclear-integrated SOEC process. INL/RPT-22-66117 includes cost estimates of the SOEC HTE process, including the thermal energy delivery loop, but does not include nuclear integration costs, including any costs required to modify the NPP piping or electrical systems, engineering costs, permitting costs, or costs associated with curtailment of nuclear plant operations that may be required to connect the NPP steam system and thermal energy delivery loop.

INL report INL/RPT-22-66117 provides capital and operating cost estimates for first of a kind (FOAK) and nth-of-a-kind (NOAK) plant types. No difference in plant performance (energy requirements, hydrogen production rates, hydrogen product purity, etc.) is assumed between FOAK and NOAK plant types. The primary distinction between these plant types for the purposes of this analysis are reductions in the capital and operating costs that occur as the technology matures and learning effects are realized as the technology deployment advances from FOAK status to NOAK status.

The FOAK plant type assumes that each electrolysis unit (i.e., a 25 MW-dc block) installed realizes cost reductions via learning effects associated with manufacture and installation. The total capital costs for the FOAK plant type are equal to the cumulative costs of each modular unit, where the cost of each modular unit is lower than the previous modular unit. INL/RPT-22-66117 assumes a 95% learning rate, indicating that a 5% reduction in costs is expected with each doubling in the number of units produced.

As the number of units produced increases, the projected rate of cost reductions decreases, and cost reductions due to learning effects become less significant. At this point NOAK status is achieved and the unit cost of each modular unit is assumed to be equal to the cost of the Nth unit, with no further cost reduction due to learning effects considered. INL/RPT-22-66117 assumes that NOAK status is achieved upon installation of 100 blocks, with each block having a capacity of 25 MW-dc. Therefore, NOAK status would be achieved after 2.5 GW-e electrolysis capacity has been installed. This definition of NOAK status is maintained in the current analysis.

This analysis assumes that balance of plant (BoP) components are based on currently available technologies and equipment. The specified electrolyzer stack performance is aligned with current to near-term SOEC stack performance. However, the stack costs are assumed to be dependent on the stack manufacturing capacity available at the time the project equipment is procured. As stack manufacturing capacity increases stack production costs are estimated to decrease, as shown in Figure B-6. Currently, several SOEC stack manufacturers, including FuelCell Energy and Haldor Topsoe, are expanding production facility capacity to the tens or hundreds of MW per year range. FuelCell Energy is currently in the process of expanding SOEC

manufacturing capacity to 40 MW/year at their Calgary facility and plans to add an additional 400 MW/yr of manufacturing capacity in the United States. [25] Haldor Topsoe is currently constructing an SOEC manufacturing facility with a 500 MW/yr production capacity and potential to expand up to 5 GW/yr production capacity. [26]–[29]

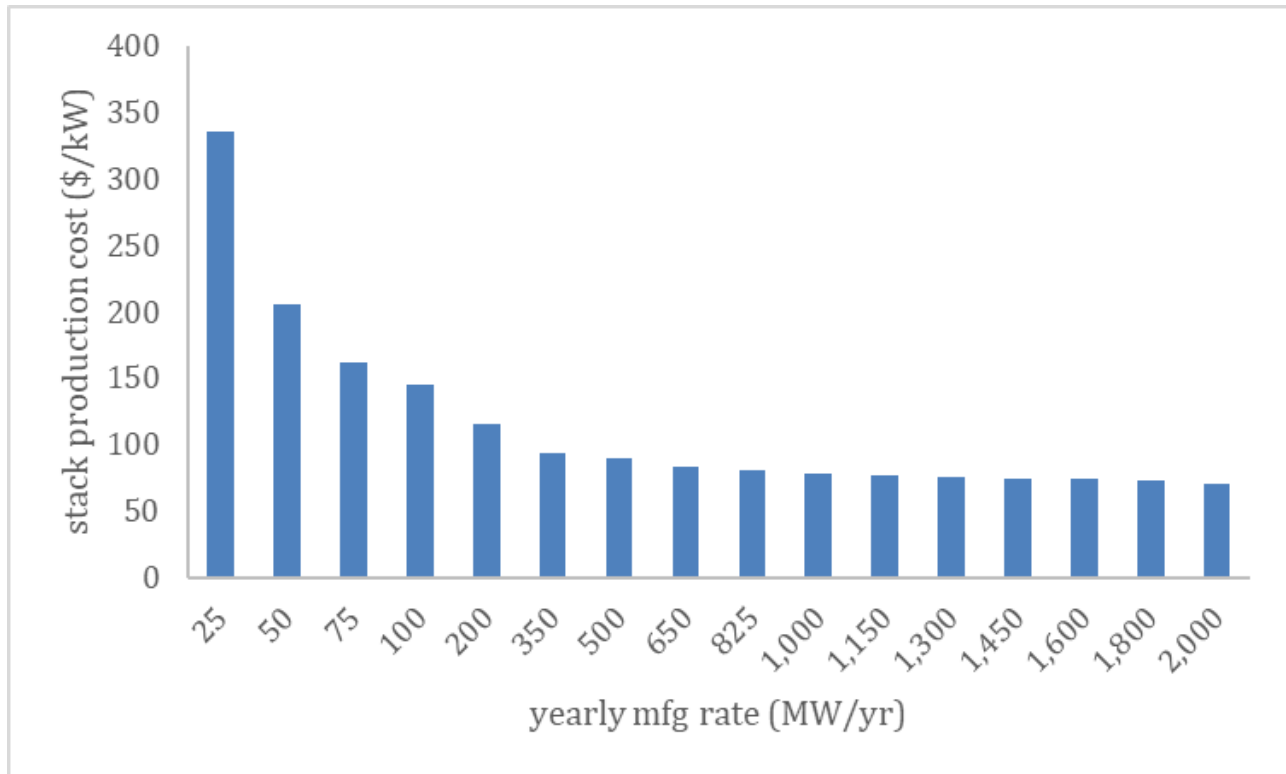

Figure B-6. Total manufacturing cost of solid oxide electrolysis stack using hydrogen electrode-supported cell construction. [30]

INL/RPT-22-66117 provides CAPEX estimates as functions of plant capacity. The CAPEX estimates include contributions from modular equipment components and scalable equipment components. The electrolysis stacks and supporting BoP equipment, such as the feedwater vaporizers, recuperators, topping heaters, recycle stream blowers, sweep gas system, etc., are classified as modular equipment. The modular equipment is specified to be installed in blocks with a predefined unit capacity of 25 MW-dc. Electrolysis plant capacities greater than 25 MW-dc are achieved through multiple blocks installed and operated in parallel. The cost of the modular equipment varies between a FOAK and a NOAK plant type, with the FOAK plant type normalized capital costs decreasing due to learning effects as the plant capacity increases and the NOAK plant type normalized capital costs specified as constant as a result of the learning curve leveling out once the Nth unit has been deployed.

The thermal energy delivery loop, control room, and high-pressure product compression are classified as scalable equipment components. The scalable equipment components are installed at capacities that match that of the overall HTE process. Scalable equipment supports the electrolysis operations that occur in multiple HTE blocks (e.g., a single thermal energy delivery loop to supply the thermal energy demands of all electrolysis blocks in a HTE plant). Therefore, the scalable equipment can achieve normalized cost reductions via economies of scale in larger installations. Conversely, the normalized costs for the scalable equipment will be higher for smaller scale HTE plant installations. HTE CAPEX were estimated based on data and correlations from INL/RPT-22-66117 with following updates or revisions:

- INL RPT-22-66117 is based on a modular system construction with 25 MW-dc electrolyzer blocks. The high temperature steam electrolysis cost estimates in the present analysis are based on the cost functions derived for a modular system, but the requirement for integer numbers of blocks has been relaxed for modeling purposes. The analysis therefore assumes that the block size could be modified to match the quantity of power available from the NPP without affecting the cost correlations or that the capacity of the high temperature steam electrolysis system installed would be rounded up to a multiple of 25 MW-dc.
- 10% contingency and 30% markup added to \$78/kW-dc stack costs (\$112/kW-dc total). Maintained assumption of 1,000 MW/yr stack manufacturing capacity. [30]
- Rectifier cost updated to \$220/kW. [15]
- Removed learning curve cost reductions from “engineering & design” and “process contingency” indirect cost multipliers, which are included in Table B-3.

Table B-3. Indirect cost multipliers.

Indirect Cost Multipliers	
Site preparation	2%
Engineering & design	10%
Process contingency	7.2%
Project contingency	7.2%
Legal and Contractor fee	15%
Land	1%

Plots of the FOAK and NOAK plant type normalized capital costs inclusive of the updates or revisions to the analysis presented in INL/RPT-22-66117 are shown in Figure B-7.

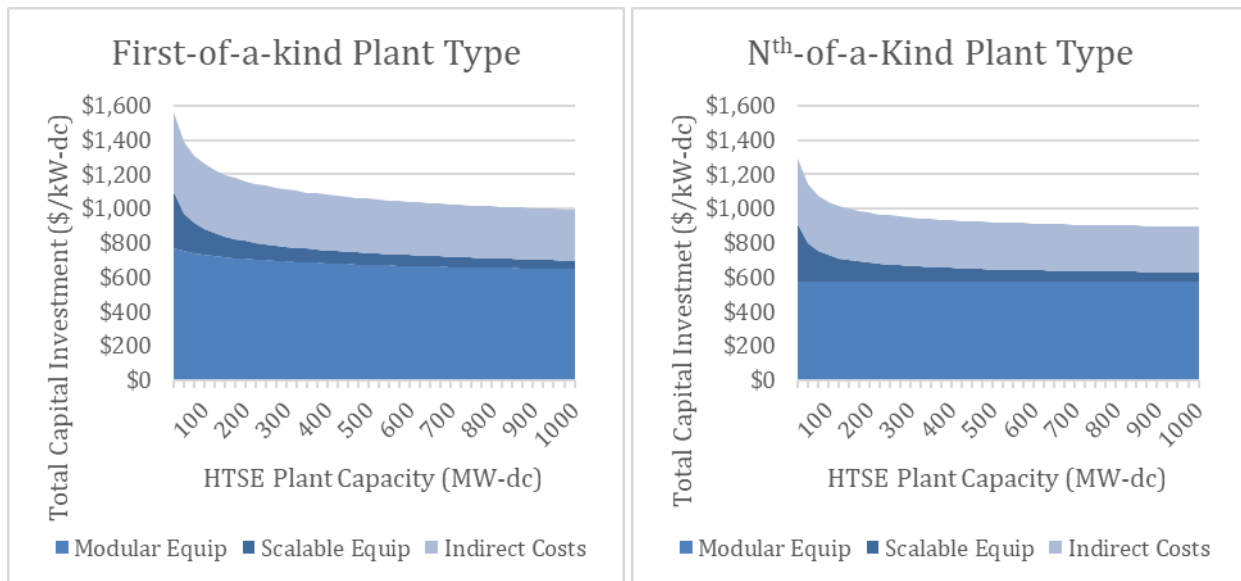

Figure B-7. FOAK (left) and NOAK (right) HTE plant capital costs as function of plant capacity.

O&M costs are estimated as a function of the plant capacity. Larger HTE plants are assumed to require a greater number of plant staff, with a scaling exponent of 0.25 used to estimate the number of full time employees relative to the baseline value specified in INL/RPT-22-66117. Similarly, plant maintenance costs will increase with the HTE plant capacity. O&M costs are estimated using the cost factors specified in INL/RPT-22-66117. The stack replacement costs are estimated based on the assumption of a 4 year stack life. The impact of stack degradation on the annual hydrogen production is accounted for by including an adjustment

to the capacity factor (assuming constant voltage operation) and by incorporating annual stack addition or replacement costs to restore system capacity at beginning of each operating year. FOAK and NOAK plant type fixed and variable OPEX estimates are provided in Figure B-8.

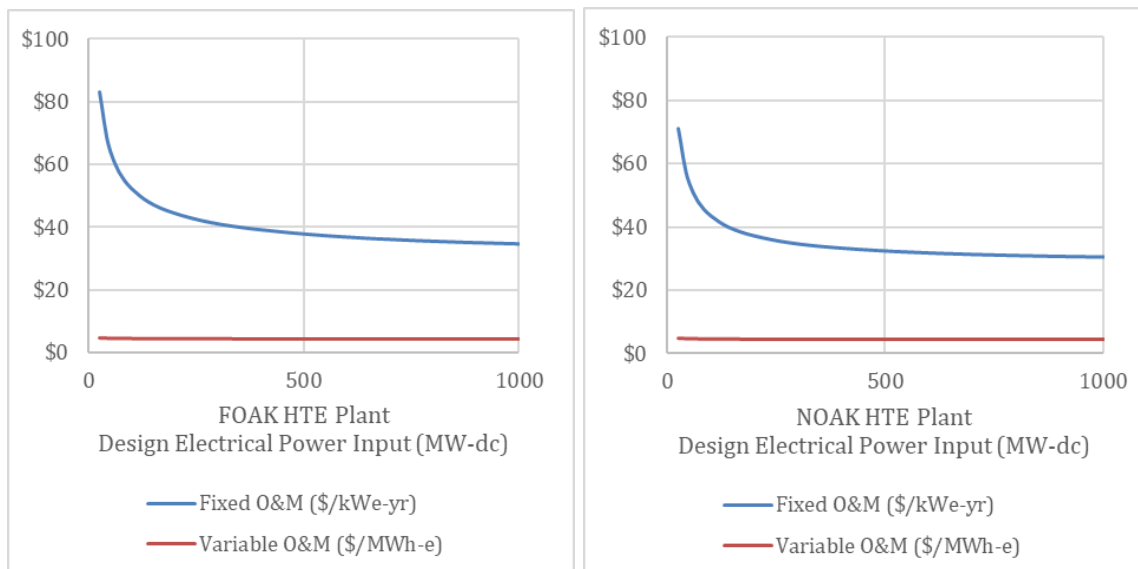

Figure B-8. FOAK (left) and NOAK (right) HTE plant fixed and variable operating and maintenance costs as function of plant capacity.

Key performance and cost specifications for FOAK and NOAK high-temperature SOEC hydrogen production system with an average production capacity of 70,000 kg/day (100 MW-dc) are presented in Table B-4.

Table B-4. SOEC system performance and cost specifications.

Parameter	FOAK Plant Type	NOAK Plant Type
Design Hydrogen Production Rate	70,000 kg/day	70,000 kg/day
System Power Input	107.8 MW-ac	107.8 MW-ac
Stack Power Input	100.0 MW-dc	100.0 MW-dc
Thermal Energy Input	18.8 MW-th	18.8 MW-th
Normalized System Electric Power Input (includes power to inverter, pumps, blowers, compressors, and electrical resistance topping heaters)	36.8 kWh-ac/kg	36.8 kWh-ac/kg
Normalized System Thermal Power Input	6.4 kWh-th/kg	6.4 kWh-th/kg
Process Water Requirement	166 k-gal/day	166 k-gal/day
Cooling Water Flow Rate (once-through)	2,700 k-gal/day	2,700 k-gal/day
Hydrogen Product Pressure	20 bar	20 bar
Direct Capital Costs (DCC)	\$886/kW-dc (2020 USD)	\$733/kW-dc (2020 USD)
Total Capital Investment (TCI)	\$1265/kW-dc (2020 USD)	\$1046/kW-dc (2020 USD)
Fixed O&M Costs	\$65/kWdc-yr (2020 USD)	\$56/kWdc-yr (2020 USD)
Variable O&M Costs (excluding energy costs)	\$4.8/MWh-dc (2020 USD)	\$4.6/MWh-dc (2020 USD)

B-2. APPENDIX B REFERENCES

- [1] Schmidt, O., et al. 2017. “Future cost and performance of water electrolysis: An expert elicitation study.” *International Journal of Hydrogen Energy*, vol. 42, no. 52, pp. 30470-30492. <https://doi.org/10.1016/j.ijhydene.2017.10.045>.
- [2] Carmo, M., et al. 2013. “A comprehensive review on PEM water electrolysis.” *International Journal of Hydrogen Energy*, vol. 38, no. 12, pp. 4901-4934. <https://doi.org/10.1016/j.ijhydene.2013.01.151>.
- [3] Shiva Kumar, S. and Himabindu, V. 2019. 2019. “Hydrogen production by PEM water electrolysis – A review.” *Materials Science for Energy Technologies*, vol. 2, no. 3, pp. 442-454. <https://doi.org/10.1016/j.mset.2019.03.002>.
- [4] Boardman, R. D., Bragg-Sitton, S. M., and Otgonbaatar, U. 2022. “Developing a low-cost renewable supply of hydrogen with high-temperature electrochemistry.” *MRS Bulletin*, vol. 47, no. 3, pp. 314-325. <https://doi.org/10.1557/s43577-022-00278-6>.
- [5] Hydrogen Newsletter. n.d. “Top list of Commercial Electrolyzers for Green Hydrogen Production.” Accessed June 2, 2023. <https://www.hydrogennewsletter.com/top-commercial-electrolyser-for/>.
- [6] Acevedo, Y., et al. 2023. “Comparative Study of Levelized Cost of Hydrogen for Alkaline, PEM, AEM, and SOE Electrolyzer Plants.” *2023 Hydrogen and Fuel Cell Seminar*, Long Beach, California, February 7-9. <https://www.fuelcellseminar.com/2023technicalsessions>
- [7] International Energy Agency. 2019. “The Future of Hydrogen: Seizing today’s opportunities.” IEA. https://iea.blob.core.windows.net/assets/9e3a3493-b9a6-4b7d-b499-7ca48e357561/The_Future_of_Hydrogen.pdf.
- [8] ITM Power. 2023. *Two 100 MW electrolyser contracts signed with Linde Engineering*. Accessed June 5, 2023. <https://itm-power.com/news/two-100-mw-electrolyser-contracts-signed>.
- [9] Cummins. 2020. “HyLYZER Water Electrolyzers.” <https://www.cummins.com/sites/default/files/2021-08/cummins-hylyzer-1000-specsheet.pdf>.
- [10] ITM Power. n.d. *Products: World’ class turn-key electrolysers from 600 kW to 100 MW*. Accessed June 7, 2023. <https://itm-power.com/products>.
- [11] NEL. n.d. *M-Series PEM Electrolyser*. Nel Hydrogen. Accessed June 7, 2023. <https://nelhydrogen.com/product/m-series-3/>.
- [12] Plug Power. 2022. *Plug EX-4250D Electrolyzer*. Accessed June 7, 2023. <https://resources.plugpower.com/electrolyzers/ex-4250d-f041122>.
- [13] Siemens Energy. n.d. “Silyzer 300: The next paradigm of PEM electrolysis.” <https://assets.siemens-energy.com/siemens/assets/api/uuid:a193b68f-7ab4-4536-abe2-c23e01d0b526/datasheet-silyzer300.pdf>.
- [14] Peterson, D., Vickers, J., and DeSantis, D. 2020. “DOE Hydrogen and Fuel Cells Program Record #19009: Hydrogen Production Cost from PEM Electrolysis – 2019.” https://www.hydrogen.energy.gov/pdfs/19009_h2_production_cost_pem_electrolysis_2019.pdf.
- [15] Holst, M., et al. 2021. “Cost Forecast for Low-Temperature Electrolysis – Technology Driven Bottom-up Prognosis for PEM and Alkaline Water Electrolysis Systems.” Fraunhofer Institute for Solar Energy Systems ISE. <https://www.ise.fraunhofer.de/content/dam/ise/de/documents/publications/studies/cost-forecast-for-low-temperature-electrolysis.pdf>.
- [16] Singh Aulakh, D. J., Boulama, K. G., and Pharoah, J. G. 2021. “On the reduction of electric energy consumption in electrolysis: A thermodynamic study.” *International Journal of Hydrogen Energy*, vol. 46, no. 33, pp. 17084-17096. <https://doi.org/10.1016/j.ijhydene.2021.02.161>.
- [17] Bloom Energy. 2021. “The Role of Solid Oxide Technology in the Hydrogen Economy: A Primer.” https://f.hubspotusercontent30.net/hubfs/5242085/BE21_22%20Hydrogen-white-paper_D.pdf.

- [18] O'Brien, J. E. 2008. "Thermodynamic Considerations for Thermal Water Splitting Processes and High Temperature Electrolysis." International Mechanical Engineer Congress and Exposition, Boston, Massachusetts, October 31-November 6. <https://inldigitallibrary.inl.gov/sites/sti/sti/4113677.pdf>
- [19] Brisse, A., Schefold, J., and Zahid, M. 2008. "High temperature water electrolysis in solid oxide cells." *International Journal of Hydrogen Energy*, vol. 33, no. 20, pp. 5375-5382. <https://doi.org/10.1016/j.ijhydene.2008.07.120>.
- [20] Wendt, D. S., Knighton, L. T., and Boardman, R. D. 2022. "High Temperature Steam Electrolysis Process Performance and Cost Estimates." Idaho National Laboratory, INL/RPT-22-66117. <https://doi.org/10.2172/1867883>.
- [21] Pinsky, R., et al. 2020. "Comparative review of hydrogen production technologies for nuclear hybrid energy systems." *Progress in Nuclear Energy*, vol. 123, 103317. <https://doi.org/10.1016/j.pnucene.2020.103317>.
- [22] Casteel, M. 2023. "TA018 High Temperature Electrolysis, Stack, and Systems Testing." DOE Hydrogen Program 2023 Annual Merit Review, Arlington, VA, June 5-8. https://www.hydrogen.energy.gov/pdfs/review23/sdi000_adams_2023_o.pdf
- [23] Ghezal-Ayagh, H. 2023. "TA039 Solid Oxide Electrolysis System Demonstration." DOE Hydrogen Program 2023 Annual Merit Review, Arlington, VA, June 5-8.
- [24] Sylvester, D. 2023. "NE002 LWR Integrated Energy Systems Interface Technology Development & Demonstration." DOE Hydrogen Program 2023 Annual Merit Review, Arlington, VA, June 5-8.
- [25] Market Watch. 2023. "8-K: FuelCell Energy Inc.". Accessed June 19, 2023. <https://www.marketwatch.com/press-release/8-k-fuelcell-energy-inc-2023-06-08>.
- [26] Topsoe. 2022. "Annual Report 2021." https://www.topsoe.com/hubfs/DOWNLOADS/DOWNLOADS%20-%20Annual%20reports/2021/Topsoe_Annual%20Report%202021.pdf.
- [27] Parkes, R. 2022. "World's largest' | Topsoe plans 5GW solid-oxide hydrogen electrolyser factory as it signs off first 500MW." RECHARGE. Accessed June 19, 2023. <https://www.rechargenews.com/energy-transition/worlds-largest-topsoe-plans-5gw-solid-oxide-hydrogen-electrolyser-factory-as-it-signs-off-first-500mw/2-1-1288647>.
- [28] Green Car Congress. 2022. "Topsoe to build world's largest SOEC electrolyzer production facility; 500 MW scalable to 5 GW; focusing on Power-to-X." Accessed June 19, 2023. <https://www.greencarcongress.com/2022/05/20220524-topsoe.html>.
- [29] Process Worldwide. 2022. "Topsoe to Build World's Largest SOEC Electrolyzer Plant in Denmark." Green Energy. Accessed June 19, 2023. <https://www.process-worldwide.com/topsoe-to-build-worlds-largest-soec-electrolyzer-plant-in-denmark-a-a310d2402cd3e1f9e42951d4daf750d2/>.
- [30] James, B. D. and Murphy, B. 2021. "Solid Oxide Electrolysis Stack Manufacturing Cost Analysis." Strategic Analysis, Inc.

APPENDIX C

Power Uprate and Nuclear Fuel

While nuclear fuel management is generally moderately impacted by small power uprates (e.g., higher proportion of fresh fuel loaded during refueling, slight increase in enriched uranium), new types of nuclear fuels with higher uranium enrichment may also enable larger power uprates, as well as longer cycles, and have a major effect on the economics of nuclear plants. As discussed in Section 5.2, the financial tool developed for this effort allows the user to input incremental fuel costs for the uprated power. Users may run sensitivities on various fuel types to examine potential benefits for utilizing advanced fuels to help achieve power uprate. While not the focus of this effort, there is synergy with advanced fuels and power uprate. As a result, this appendix documents a summary of relevant technical and cost information as well as provides resources for utilities to consider for power uprate fuel considerations.

C-1. HISTORICAL FUEL CONSIDERATIONS

The cost of fuel is traditionally included in plant variable operating costs and generally contributes to a minor portion of total generating costs relative to the total capital and plant O&M costs. Fuel costs are site specific and depend on numerous factors, including:

- Cost of nuclear fuel component: uranium oxide concentration, conversion, enrichment, and fabrication (about half of total fuel cost).
- Operation: type of reactor, capacity, core design, fuel burnup, cycle length, load factor, etc.
- Used fuel management and final waste disposal.

NEI's report *Nuclear Costs in Context*, published in October 2022 [1] provides a history of fuel cost in \$/MWh in 2021 dollars in the United States. The analysis shows a decrease of approximately 35% in fuel cost between 2012 and 2021. The 2021 costs for fuel only are presented in Table C-1. The table shows an average cost for fuel of \$5.55/MWh, with less than 10% variation for all categories.

Table C-1. 2021 fuel cost summary.

Category	Cost (\$/MWh)
All United States	5.55
Plant Size	
Single-Unit	5.46
Multiunit	5.57
Operator	
One Plant	5.77
Multiple Plants	5.49
Revenue Structure	
Cost of Service	5.95
Merchant	5.05
Type	
BWR	5.38
PWR	5.65

The war in Ukraine is upending some of the cost saving in 2022 and 2023, due to an increase of up to 40% of the cost of uranium per [2]. However, this sharp increase is expected to be temporary as countries secure other uranium sources and develop alternative procurement avenues. Moreover, most utilities apply long-term procurement strategies to reduce their exposure to short term market fluctuation.

For additional publicly available data, the Energy Information Administration (EIA) publishes both U_3O_8 and enrichment service prices in their annual *Uranium Marketing Annual Report* which, when combined with utility fabrication contracts and conversion contracts, can be used to estimate fuel costs. Several proprietary reports can also be purchased by utilities to project future fuel costs.

The relative impact of fuel cost elements is described in a study from the World Nuclear Association [4] indicates even doubling the uranium price would have a minor impact on the overall plant economics:

Doubling the uranium price (say from \$25 to \$50 per lb U_3O_8) takes the fuel cost up from 0.50 to 0.62 ¢/kWh, an increase of one-quarter, and the expected cost of generation of the best US plants from 1.3 ¢/kWh to 1.42 ¢/kWh (an increase of almost 10%). So while there is some impact, it is minor,...

This is supported by another analysis from the International Energy Agency (IEA) with the Nuclear Energy Agency (NEA) Organization for Economic Co-Operation and Development documented in [5]. The results of fuel cost sensitivity of the average generation costs concluded that:

...nuclear plants are only slightly affected by increasing or decreasing fuel costs by 50% in either direction – due to total nuclear costs being dominated by fixed costs. Average median costs change by about 8% in either direction when reaching the end of the sensitivity range.

In 2001 and 2002, EPRI published two studies to determine the optimum cycle length and discharge burnup for nuclear fuel achievable within the 5% uranium enrichment limit (Reference 45) and with enrichments greater than 5% [3]. The main conclusions of the studies were that:

Within the 5% uranium enrichment limit:

For BWRs: "For each 1000 MWD/MTU increase in batch average discharge burnup, the fuel costs declined by 0.56% for 24 month cycles, 0.36% for 18 month cycles, and 0.05% for 12 month cycles."

For PWRs: "...the analysis shows that a 1000 MWD/MTU increase in batch average discharge burnup would result in a \$0.56 million decline in cost (0.7%) for the 24 month cycle, \$0.56 million decline in cost (1.1%) for the 18 month cycle, and \$0.15 million decline in cost (0.5%) for the 12 month cycle. However, the burnup extensions that are achievable without exceeding the 5.0 w/o enrichment limit are different for each cycle length."

Beyond the 5% uranium enrichment limit: the study only considered a 24-month cycle for a BWR and a 18 month cycle for a PWR. The results showed that for both the BWR and PWR, the fuel costs continued to decline with increasing batch average discharge burnup.

C-2. ADVANCED FUEL CONSIDERATIONS

This low sensitivity of generation costs to changes in fuel costs mentioned before also extends to the increased cost of using advanced fuel, such as the ATF near-term concept, with higher enrichment. An analysis by NEI documented in [1] on the economic benefits of ATF concepts concluded that:

economic benefits of ATF concepts are predicated upon the capacity of the new fuel product to support a wider range of operating conditions, and the ability to translate that wider range of allowable operating conditions into plant equipment and operating strategies that ensure safety and reduce operating costs.

Further, the study identifies potential benefits regarding fuel cycle flexibility and improved economic performance, including:

- Increase in allowable burnup
- Improvement of thermal margins
- Enabling of longer cycles when previously not possible
- Enabling of higher enrichments
- Reduction of batch loading sizes
- Reduction of volume of spent fuel.

Note that while the low sensitivity of generation costs to changes in fuel costs is generally correct for power uprate projects where significant revenue generation is being considered, it may not be universally correct for all combinations of the potential application. For example, fuel cost changes are not linear for a standalone evaluation of extending to 24-month cycles, and they have a material impact on the decision to change cycle length. The financial model developed herein allows the user to investigate operating for 18 or 24 month cycles as well as variations in fuel costs.

A recent study by Westinghouse which analyzed the economic impacts of using an optimized fuel management strategy that included higher enrichment and higher burnup fuel technology for power uprates [6]. Several cases of small power uprates (approximately 4%) and different cycle lengths (18 or 24 months cycles) were considered globally for PWRs, with the analysis providing LCOE improvement ranges. The analysis shows that optimizing fuel use and transitioning to advanced fuel technology provided an economical benefit in almost all cases. Utilities should consider this information when considering power uprates and ensure an optimized fuel strategy is pursued considering technical, regulatory, and financial benefits and risks.

C-3. APPENDIX C REFERENCES

- [1] NEI. 2022. “Nuclear Costs in Context.” Nuclear Energy Institute. <https://www.nei.org/resources/reports-briefs/nuclear-costs-in-context>.
- [2] Saefong, M. P. 2022. “Why Russia’s invasion of Ukraine lifted uranium prices to their highest in over a decade.” MarketWatch. <https://www.marketwatch.com/story/why-russias-invasion-of-ukraine-lifted-uranium-prices-to-their-highest-in-over-a-decade-11647537166>.
- [3] Optimum Cycle Length and Discharge Burnup for Nuclear Fuel: Phase 1: Results Achievable Within the 5% Enrichment Limit, EPRI, Palo Alto, CA: 2001. 1003133.
- [4] WNA. n.d. “Economics of Nuclear Power.” World Nuclear Association. (Last Updated August 2022). <https://www.world-nuclear.org/information-library/economic-aspects/economics-of-nuclear-power.aspx>.
- [5] IEA. 2020. “Projected Costs of Generating Electricity.” License CC BY 4.0. <https://www.iea.org/reports/projected-costs-of-generating-electricity-2020>.
- [6] B. Durham, F. Franceschini, H. Lam, and C. Wagener. 2022, “Levelized Cost of Electricity Evaluations for Westinghouse Advanced Fuel Management with High Enrichment and High Burnup Fuel to Optimize PWR Economics.” Proc. in the TopFuel 2022 Light Water Reactor Fuel Performance Conference, Raleigh, NC: Oct. 9–13, 2022. <https://www.ans.org/pubs/proceedings/issue-3218/>.

APPENDIX D

SAFETY ASSESSMENTS OF POWER UPRATES

D-1. INTRODUCTION

Power uprates of nuclear power plants (NPP) can be achieved by either increasing the reactor thermal power output or improving electricity generation efficiency in the secondary side of the NPP. The most common way to increase the thermal power output is by increased volume of the fissile materials in the reactor and optimization of core design and operational conditions. The increase of the fissile materials could be achieved by increasing the uranium enrichment or fuel density. Optimization techniques could be applied to design the reactor core with increased enrichment and the fuel reloading pattern for the equilibrium fuel cycle. During these approaches, the safety margins should be maintained as demonstrated by the system safety analyses and fuel performance analyses.

For the pressurized water reactors (PWR), the thermal power increase can also be achieved by the increase of coolant average temperature and primary side flow rate to steam generators which will increase steam generation to the main turbine resulting in increased power. Increase in pressure may allow higher temperature operation, but it may also require major system modifications and safety analyses which may reduce the benefits from the power uprate. [1] Hence, retaining the same pressure in a PWR is one of the key principles in a power uprate. For boiling water reactors (BWR), optimizing the control rod pattern or increasing the reactor recirculation flow increases the steam generation in the reactor core.

Generally, the smaller power uprates (less than approximately 2%) can be achieved through improvement of the primary and secondary sides' operational performance, protection and monitoring systems, operator performance, etc. Removing over-conservatisms by improving state-of-the-art computational analysis codes will also help the power uprate. This method is called measurement uncertainty recapture (MUR). The next level of a power uprate is called the "stretch power uprate" which increases power up to 7% within the design capacity of the plant. This method requires significant hardware changes without violating any regulatory acceptance criteria. The "extended power uprate" represents a power increase greater than 7%. This approach may be limited by critical reactor components such as reactor vessel, pressurizer, primary heat transport systems, piping, or secondary components (e.g., a turbine or a main generator).

As of 2023, a total of 171 power uprate have been approved for the United States (U.S.). [2] In 1970s and 1980s, most of power uprate were done with the "stretch power uprate" method. Later power uprate was done by "extended power uprate" and MUR methods or combined. The MUR method has been more dominant since the 2010s. The first power uprate was done at Calvert Cliffs NPP unit 1 and 2 in 1977. Both were designed for 2,560 MWth and uprated to 2,700 MWth (5.5%) within two years of plant commencement using the "stretch power uprate" method. In 2009, the second power uprate was done at Calvert Cliffs NPP unit 1 and 2 by improving accuracy of the feedwater flow measurement which falls under the MUR method. This approach is very common for the MUR power uprate method. The core power was increased to 2,737 MWth (1.38%). Note that the primary system pressure remains the same as the original design during the power uprate (i.e., 15.513 MPa or 2,250 psia).

Recent research has shown that the use of the accident-tolerant fuel (ATF) could give more flexibility in power uprate as well as extended burnup operation up to 24 months or even longer. [3] These ATFs were originally designed to mitigate hydrogen production during a postulated accident, but could hold higher thermal power, thus higher enrichment, thanks to their better mechanical strength compared to conventional Zr-based claddings. The approach proposed use of a 21×21 fuel assembly instead of the conventional 17×17 array to increase the amount of U-235.

The purpose of this report is to review technical background and propose a demonstration methodology and plan for power uprates using conventional Zr cladding and ATF technology along with core design using the fuel reloading optimization platform. For ATFs, FeCrAl-based and Cr-coated Zr cladding will be considered. An artificial intelligence (AI)-based fuel reloading optimization platform will be used. For the safety analysis, selected limiting design basis accident (DBA) scenarios will be assessed mainly focused on three- or four-loop PWR reactor. Fuel performance and source term analysis will also be conducted.

D-2. TECHNICAL BACKGROUNDS

Relative aspects of power uprates are presented in the sections below.

D-2.1 Technical Issues in Power Uprate

A power uprate generally aims to minimize plant modifications since the main goal is economic benefits. For this reason, one of the most important criteria is maintaining the same pressure in the nuclear steam supply system (NSSS)^f. The increase of NSSS pressure will require system structure integrity review and safety analyses which were addressed in safety analysis reports. Hence, most of the power uprates were done by retaining system pressure to avoid unnecessary costs.

The higher thermal power achieved by higher fuel enrichment may need adjustments to operational coolant temperature by changing the coolant flow rate. However, an increase of the coolant flow rate may increase the possibility of the flow-induced vibration and necessitate frequent system safety inspections which will increase the maintenance costs and decrease economic benefits. Hence, maintaining the optimal operational conditions is the most straightforward approach to power uprates.

During the power uprate of PWR, the major challenge is the capacity of the steam generator. [[1]] Increase of thermal power will drop moisture carryover to below the design limit with the existing operating feedwater temperature. As a consequence, a steam generator's downstream piping and valves may be exposed to larger possibilities of erosion and corrosion. For the BWR, the thermal limit of the fuel will limit the power uprate which still has a large margin for further uprate. [1] However, an increase of thermal power will change the reactor core power flow map, which requires caution. The capacity of the reactor recirculation pump, steam separator and dryer are also major constraints for the power uprate.

The major constraint of the power uprate is fuel performance. For the conventional Zr cladding and UO₂ fuel, the maximum amount of a power uprate is limited to 8% for PWR and 20–30% for BWR which could be obtained from increasing enrichment, using burnable poisons, and optimizing fuel assembly and core batch. [1] Fuel reliability will remain safe from the power uprate itself, but it could be influenced by a change of water chemistry (e.g., boron concentration). Additional fuel monitoring and inspection are recommended if a power uprate modifies plant, fuel type, and water chemistry.

The secondary systems may need upgrades or replacement to improve the power uprate especially for turbine and other relevant systems. Generally, the power uprate increases irradiation of materials and vibration which yields a decrease of component and structure lifetime.

D-2.2 Physics-Based Aspects in Power Uprate

The physics-based aspects include analyses to ensure safety, performance, and reliability of the NPP while in a power uprate. [4] The analyses can include the full scope guided by the safety analysis report for plant safety, radioactive waste management, electrical grid stability, equipment qualification, instrumentation and control (I&C) systems, etc.

^f For PWR, temperature shall not exceed 647 K (374°C; 705°F) or a pressure of 22.064 MPa (3200 psi or 218 atm) which are the critical points of water. In normal operation, temperature reaches up to 325°C with pressure of 15.5 MPa. Each NPP has its own limitation of operational temperature and pressure.

To evaluate power uprate, the parameters of interest need to be established mainly focused on NSSS reliability, system safety margins, and potential upgrade or replacement of the equipment. In general, most important parameters for the physics-based aspects are:

- Reactor pressure
- Core flow
- Steam flow
- Feedwater flow
- Reactor vessel inlet/outlet temperature (in PWR)
- Steam generator — outlet pressure and feedwater temperature (in PWR)
- Turbine capacity
- Main condenser limits.

D-2.3 Accident Tolerant Fuels

The ATFs could be categorized into two major groups: advanced fuel cladding and advanced fuel pellets. For power uprate application, there are two different types of Cr-coated Zr cladding and FeCrAl alloy cladding.

The Cr-coated Zr cladding has the main advantage of preserving the benefits of the base zirconium such as the low-thermal absorption cross section and mechanical properties. It also improves its oxidation and corrosion resistance in accident conditions. Chromium forms an extremely protective oxide layer, Cr₂O₃, allowing the coating layer to be beneficial in relatively thin layers. This helps reduce the neutronic penalty from the thermal neutron absorption of chromium, though it has a high absorption cross section and allows current fuel designs to implement coated cladding without geometric reconfiguration. However, some outstanding issues need to be addressed before full deployment, such as cladding-coating chemical interactions, irradiation performance, and coating performance during transient scenarios. [5]

The FeCrAl alloy claddings are ferritic and martensitic steel alloys have highly corrosion resistance even in very high temperatures due to the formation of a thin aluminum oxide layer. FeCrAl alloy has superior mechanical strength in comparison to Zr alloy cladding; however, it has the disadvantage of increased neutron absorption due to the presence of iron in the alloy and increased tritium release into the reactor coolant. To compensate for neutron loss, FeCrAl cladding fuel is used to increase fuel enrichment or decrease cladding thickness. The alloy composition, classified as “nuclear grade,” is an optimized composition developed to perform in both normal and off-normal conditions of an NPP. Small quantities of select atoms or molecules are added to the base configuration of these alloys, which try to improve fuel performance by improving specific characteristics of the alloy. For the power uprate, two FeCrAl ATFs are proposed: C26M and Kanthal APMT. Table D-1 composition of two FeCrAl ATFs. [6]

Table D-1. FeCrAl alloy iterations for nuclear applications.

Alloy Designation	Vendor	Nominal Composition (wt.%)
C26M	ORNL	Fe-12Cr-6Al-2Mo-0.2Si-0.05Y
Kanthal APMT	Kanthal	Fe-21Cr-5Al-3Mo

D-2.4 Core Configuration

The core design may have two stages: fuel assembly and equilibrium core design. Fuel assembly will basically remain a generic 17 × 17 lattice but a larger lattice size can be considered. The equilibrium fuel cycle should be considered to apply different batches based on the fuel reloading patterns.

Current regulatory guidance in operational and safety constraints were set based on the Zr-clad fuel which might be excessively conservative for ATF. However, the power uprate should follow current regulatory guidance.

D-2.4.1 Operational and Safety Constraints

Operational and safety constraints that must be satisfied during the optimization of the equilibrium cycle include reactivity and thermal limits that ensure reactor safety. Reactivity limits, which ensure negative feedback for temperature excursions, include a constraint that is the maximum soluble boron concentration. This constraint on the boron concentration is needed to control the axial offset due to boron deposition and to maintain a negative temperature coefficient of reactivity throughout the lifetime of the core. As a high-soluble boron concentration is needed to control core reactivity and prevent high-power density regions in the core, burnable poisons are added to the core design to supplement reactivity control and maintain criticality. Hence, to prevent a positive moderator temperature coefficient, the threshold for the boron concentration is set at 1300 ppm for any length of fuel cycle. [7] It is noted that for the extended burnup (24-month) core design, a negative temperature coefficient was found in a limiting core design with threshold value of 1700 ppm. [8]

Thermal limits are required to minimize radiological release during normal, transient, and accident conditions by maintaining fuel-cladding integrity. The thermal limits examined include the heat flux hot channel factor (or pin peaking factor), FQ, and the enthalpy rise hot channel factor, FΔH. FQ is the ratio of the peak pin power to the core average pin power and is used to set the fuel centerline temperature to prevent fuel damage. Table D-2 summarizes main core design parameters and their limits. Typical FQ limit used to set as 2.5 based on the large break LOCA (LBLOCA) analysis. [9]

Table D-2. Core design parameter limits.

Parameter	Limit
Heat flux hot channel factor (FQ)	2.1
Enthalpy rise hot channel factor (FΔH)	1.65
Peak pin burnup (GWD/MTU)	62
Peak boron concentration (ppm)	1300
Moderator temperature coefficient (pcm/K)	0.0

D-2.4.2 Reactivity Compensation for FeCrAl-Clad Fuel

The Zr alloy has a very small thermal neutron absorption cross section (0.2 barn). The cross section of FeCrAl is ten times larger (2.43 barn), which leads to an increased parasitic absorption of neutrons in the FeCrAl cladding material when compared to Zr alloy clad. This reactivity penalty inevitably leads to a shortened cycle length and, as such, attempts are made to match the end-of-cycle (EOC) reactivity of the FeCrAl material with that of Zr alloy, thus maintaining the cycle energy production. To compensate for this penalty, fuel design parameters could be adjusted including enrichment, fuel pellet size, number of fuel rods in a fuel assembly, or a cladding thickness combination with burnable poisons. The better mechanical characteristics of FeCrAl may allow higher enriched fuel which can be used for the power uprate.

Table D-3 shows examples of higher enriched FeCrAl-clad fuel configuration for the 24-month fuel cycle. [11] Different cases were tested with different ranges of enrichment and cladding thicknesses. The choice of cladding thickness is corroborated from the calculated minimum thickness of FeCrAl cladding based on elastic buckling and ovality. This approach could be used for the power uprate by using higher enriched fuel.

Table D-3. Case studies to compensate FeCrAl reactivity penalty.

Case	Enrichment (wt.%)	Clad Thickness (cm)	Fuel Pellet Radius (cm)
1	4.10	0.0422–0.0522	0.4096
2	4.53	0.04	0.4268
3	4.70	0.04	0.4096
4	5.0	0.0572	0.4096

Another approach is to increase the number of fuel pins in a fuel assembly. Many PWR reactors have 17×17 fuel pins in a fuel assembly. By reducing fuel pin size more fuel can be loaded in a fuel assembly. Figure D-1 shows an example of a 21×21 fuel assembly. [3]

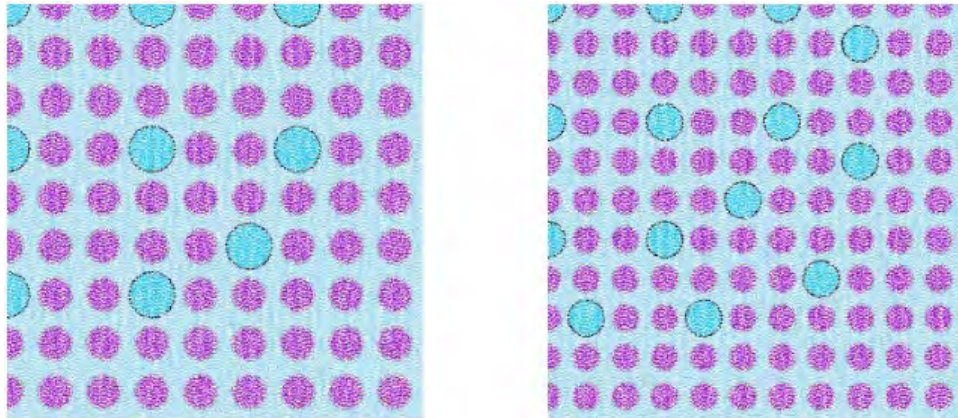

Figure D-1. Quarter symmetric of the 17×17 (left) and 21×21 (right) fuel assembly.

It is noted that Cr-coated Zr cladding does not need reactivity compensation since it uses Zr as main cladding material. Chromium has a high absorption cross section (2.9 barn) but need of reactivity compensation is negligible due to very thin coating (10–100 nm).

D-2.5 Safety Aspects in Power Uprate

The basis of the safety analyses is to ensure the safety margin is retained with increased power output. The level of safety analyses is dependent on the amount of power uprate and the complexity of the system and component operation parameter change for power uprate. The safety analyses need to include operational reliability, anticipated operational occurrences (AOO), transients and the DBAs listed in NUREG-0800. [12] It is important to determine constraints and limitation of a power uprate. An example of determining constraints would be if higher power operation will reduce the length of plant lifetime or may impact system reliability. The pressurized thermal shock phenomenon in PWR is one of the limiting factors in power uprates since higher temperature and radiation operation from a power uprate will increase reactor vessel mechanical stress and may fail during postulated accidents.

D-2.5.1 Best-Estimate Plus Uncertainties (BEPU)

Power uprate needs thorough safety analyses in both normal operation and transient status. Power uprate is mainly achieved by the reactor thermal power; however, increase of temperature, pressure, coolant flow rate, steam conversion rate, etc. will also affect system safety. The analytical method is based on the deterministic approaches as follows:

- Conservative codes using conservative models, and calculations using conservative initial and boundary conditions

- Best-estimate codes and conservative initial and boundary conditions
- Best-estimate codes and uncertainty analysis (i.e., BEPU).

In conservative analyses, however, factors as required by the regulatory body must be considered. This may include single failure criteria; supplementary failure considerations such as failure to scram; failure of the power grid; discrediting or crediting operator actions beyond certain available time, etc. [4]

The BEPU method is the most preferable approach in nuclear safety analysis since the 1980s. The main goal is to reduce the level of conservatism (i.e., to increase the knowledge of the different phenomena occurring during an operational transient or an accident). In particular, these efforts led to a revised set of rules of the 10CFR50.46 for the evaluation of ECCS performance and to the issuance of the Regulatory Guide 1.157 on using Best-Estimate (BE) methods, which quantifies the uncertainty of a figure of merit (FOM). [13]

The BEPU method allows the use of BE computational tools and of realistic initial and boundary conditions. The BE computational tools solve nuclear thermal-hydraulics through validated numerical methodologies. This includes RELAP5, TRAC, CATHARE, etc. Uncertainties of the code and of the boundary and initial conditions have to be identified, quantified, and combined. An adequate number of sensitivity analyses should also be performed. Figure D-2 shows the benefit of BEPU method. Compared to the conservative value, the BEs value is closest to the actual value. By applying an uncertainty range to the best-estimate value, additional safety margins could be acquired even from the upper limit of the uncertainty range which is named as a BEPU benefit.

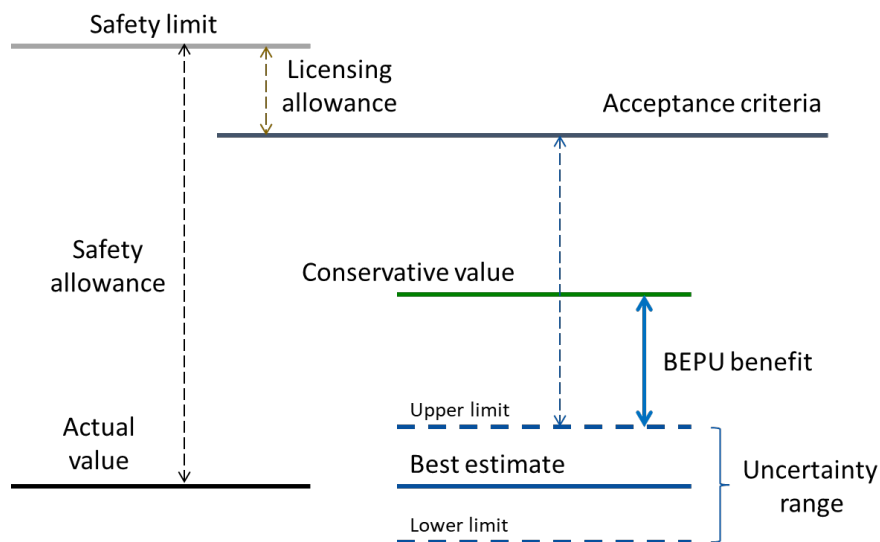

Figure D-2. Safety margins with conservative and BEPU calculations. [14]

The BEPU method could be extended to multiphysics risk-informed BEPU (i.e., MP-RI-BEPU) which includes realistic model analyses with BEPU combined with probabilistic safety analysis to quantify the availability of safety-significant systems. BEPU method can provide a safety analysis based on the real frequency of every possible accidental event and it allows the development of risk-informed decision-making.

D-2.5.2 Analysis of Normal Operation and Operational Transients – Condition I

Power uprates shall not affect the system's safety and reliability during normal operation and operational transients (NOO). The parameter of interest in analysis may vary based on the type of power uprate. If power uprate is established by increase of the steam flow, the pressure drops, dynamic loading to SSC, and system vibration will be also increased. In the case of coolant temperature increases, the analysis needs to focus on the local stress and corrosion.

The analyses need to show the safety margins are adequately maintained during the normal operation under a power uprate. The shutdown safety margin may be reduced due to power uprate. Additional analysis is necessary during refueling to ensure adequate safety margins. During the refueling, optimization of the core design is necessary because increased enrichment will change the power density map of the core and may promote the risk of film boiling or dryout phenomena. Hence, restoring the safety margin during core design and refueling is the most important parameter in normal operation under the uprated power operation.

If fuel enrichment increases for the power uprate, irradiation in the primary coolant system will also be increased. This will increase risk in radiation embrittlement and radiation-induced stress corrosion and will require additional monitoring systems. The increase in fuel enrichment will also increase waste heat, fission product, and source term.

These analyses are expected frequently or regularly during the operation, refueling, maintenance, or maneuvering of the plant or Condition I event. [14] These events are accommodated with the safety margin between any plant parameter and the value of that parameter which would require either automatic or manual protective action. Since these events occur frequently or regularly, thorough analysis is necessary for the power uprate from the point of view of affecting the consequences of fault conditions or accidents (e.g., Conditions II, III, and IV). In this regard, analysis of each fault condition described is generally based upon a conservative set of initial conditions corresponding to adverse conditions which can occur during Condition I operation as shown in Table D-4.

Table D-4. List and requirements of Condition I operation NOO scenarios.

List of events	Event requirements detail
Steady-state and shutdown operations	<ul style="list-style-type: none"> a. Power operation (>5 to 100 percent of rated thermal power) b. Startup ($K_{eff} \geq 0.99$, ≤ 5 percent of rated thermal power) c. Hot standby (subcritical, Residual Heat Removal System [RHRS] isolated) d. Hot shutdown (subcritical, RHRS in operation) e. Cold shutdown (subcritical, RHRS in operation) f. Refueling
Operation with permissible deviations	<ul style="list-style-type: none"> a. Operation with components or systems out of service b. Leakage from fuel with clad defects c. Radioactivity in the reactor coolant <ul style="list-style-type: none"> 1) Fission products 2) Corrosion products 3) Tritium d. Operation with steam generator leaks up to the maximum allowed by the <ul style="list-style-type: none"> 1) Technical Specifications 2) Testing as allowed by the Technical Specifications
Operational transients	<ul style="list-style-type: none"> a. Plant heatup and cooldown (up to 100°F/hour for the RCS, 200°F/hour for the pressurizer during cooldown, and 100°F/hour for the pressurizer during heatup) b. Step load changes (up to ± 10 percent) c. Ramp load changes (up to 5 percent/minute) d. Load rejection up to and including design full load rejection transient

D-2.5.3 Analysis of Chapter 15 Accidents – Conditions II, III, and IV

Due to power uprate, some transients could appear faster than conventional power ranges for the AOOs. Pressure transients can occur largely and rapidly in the PWR steam generator and BWR pressure vessel. The consequence will be more significant in BWRs.

In the case of transients with initiation of safety systems, a power uprate will increase decay after which will require faster activation of the emergency coolant system (ECCS). This means a power uprate may reduce the operator intervention time. Safety analysis is necessary for such cases to confirm the safety margin is retained. Power loading to certain electrical systems and components will be increased. To ensure safety, power supply systems (e.g., diesel generators, accumulators) should be reviewed for dealing with transient and potentially severe accidents.

As a consequence of power uprate, mass (i.e., steam and source term) and energy release will be larger during the steam line or coolant system leakage (e.g., loss-of-coolant accident, steam generator tube rupture, main steam line break) events due to higher thermal power, higher fuel enrichment, and higher temperature. A larger mass will be released first, followed by larger decay heat. The source term will be then be released into the reactor containment and potentially to the environment. For this reason, the entire set of safety analyses together with system stress analyses (e.g., temperature- and radiation-induced stresses) need to be renewed to demonstrate safety margin is maintained during such DBAs.

Chapter 15 of the final safety analysis report (FSAR) consists of the mandatory accident analyses for the licensing purpose or so-called DBA. There are a total of 35 accident scenarios categorized in Condition II, III, and IV. [12] The list of Condition II, III, and IV accident scenarios are given in following sections. The limiting scenarios are proposed for research or demonstration purposes of power uprate safety analysis which more focus on Condition IV events (underlined in below list).

D-2.5.3.1 Condition II – Faults of Moderate Frequency

These are defined as the incidents which may occur during a calendar year. It is also known as AOOs. These faults, at worst, result in the reactor trip with the plant being capable of returning to operation. By definition, these faults (or events) do not propagate to cause a more serious fault (i.e., Condition III or IV events). In addition, Condition II events are not expected to result in fuel rod failures or reactor coolant system (RCS) or secondary system over-pressurization. The Condition II events are:

- Feedwater (FW) system malfunctions that result in a decrease in FW temperature
 - FW system malfunctions that result in an increase in FW flow
 - Excessive increase in secondary steam flow
 - Inadvertent opening of an SG relief or safety valve
 - Loss of external electrical load.
- Turbine trip
 - Inadvertent closure of main steam isolation valves (MSIVs)
 - Loss of condenser vacuum and other events resulting in turbine trip.
- Loss of nonemergency AC power to the station auxiliaries
 - Loss of normal FW flow
 - Partial loss of forced reactor coolant flow
 - Uncontrolled rod cluster control assembly (RCCA) bank withdrawal from a subcritical or low power startup condition
 - Uncontrolled RCCA bank withdrawal at power
 - RCCA misalignment (dropped assembly, dropped assembly bank, or statically misaligned assembly)
 - Startup of an inactive reactor coolant pump (RCP) at an incorrect temperature.
- Chemical and Volume Control System (CVCS) malfunction that results in a decrease in the boron concentration in the reactor coolant.
- Inadvertent operation of the ECCS during power operation
 - CVCS malfunction that increases reactor coolant inventory

- Inadvertent opening of a pressurizer safety or relief valve
- Break in instrument line or other lines from reactor coolant pressure boundary (RCPB) that penetrate containment.

D-2.5.3.2 Condition III – Infrequent faults

By definition, Condition III occurrences are faults which may occur very infrequently during the life of the plant. They will be accommodated with the failure of only a small fraction of the fuel rods, although sufficient fuel damage might occur to preclude resumption of the operation for a considerable outage time. The release of radioactivity will not be sufficient to interrupt or restrict public use of those areas beyond the exclusion radius. A Condition III fault will not, by itself, generate a Condition IV fault or result in a consequential loss of function of the RCS or containment barriers. The following faults are in Condition III:

- Steam system piping failure (minor)
- Complete loss of forced reactor coolant flow
- RCCA misalignment (single rod cluster control assembly withdrawal at full power)
- Inadvertent loading and operation of a fuel assembly in an improper position
- LOCAs resulting from a spectrum of postulated piping breaks within the small size RCPB (e.g., small break LOCA).
 - Postulated radioactive ground releases due to liquid tank failures
 - Spent fuel cask drop accidents.

D-2.5.3.3 Condition IV – Limiting faults

Condition IV occurrences are faults which are not expected to take place but are postulated because their consequences would include the potential for the release of significant amounts of radioactive material. They are the most drastic which must be designed against and represent limiting design cases. Condition IV faults are not to cause a fission product release to the environment resulting in an undue risk to public health and safety exceeding guideline values of 10CFR100. A single Condition IV fault is not to cause a consequential loss of required functions of systems needed to cope with the fault, including those of the ECCS and the containment. Condition IV events includes:

- Steam system piping failure (major)
 - FW system pipe break
- RCP shaft seizure (locked rotor)
 - RCP shaft break
- Spectrum of RCCA ejection accidents (e.g., reactivity initiated accident, RIA)
- SG tube failure
- LOCAs resulting from the spectrum of postulated piping breaks within the large size RCPB (e.g., large break LOCA)
 - Design basis fuel handling accidents.

Recent research report that the risk of RIA becomes larger as burnup increases since rod internal pressure is higher than lower burnup operation. Especially, use of ATF gives flexibility in increasing burnup while mitigating hydrogen risk during severe accidents. Hence, safety analysis of power uprate using ATF also needs accurate analysis of RIA.

D-2.5.4 Analysis of the Severe Accident (Beyond DBA)

The power uprate may specifically affect anticipated transient without scram (ATWS) sequences with loss of boron system. This includes station blackout (SBO) due to natural disaster. The severe accident management procedure (SAMG) should be reviewed. The source term release will be higher in power uprate and need accurate assessment of the environmental consequences. Two scenarios are mainly used for the severe accident analysis: [15]

- Long-term SBO (LTSBO)
 - Core damage begins within 9 to 16 hours and reactor vessel failure about 20 hours from accident. Offsite radiological release due to containment failure about 45 hours (PWR)
- Short-term SBO (STSBO)
 - Core damage begins within 1 to 3 hours and reactor vessel failure about 8 hours from accident. Offsite radiological release is about 25 hours (PWR).

D-2.6 Computational Tools

The following computational tools are recommended for use in power uprate physics-based approaches. These tools are already available in many applications in the RISA Pathway activities.

D-2.6.1 PARCS

Developed by Purdue University, PARCS is a three-dimensional (3D) reactor core simulator designed to solve both the steady-state and time-dependent multigroup neutron diffusion equations and low-order transport equations in orthogonal and non-orthogonal geometries. [15] The cross-section library is processed by an independent module called GenPMAXS by using the data generated from the lattice physics codes such as SCALE/Polaris into the PMAXS format readable by PARCS. PARCS also has coupling capabilities with thermal-hydraulics system codes such as TRACE and RELAP5. The major features of the PARCS code are eigenvalue calculations, transient (kinetics) calculations, xenon transient calculations, decay heat calculations, pin power calculations, depletion calculations, and adjoint calculations.

D-2.6.2 RELAP5-3D

RELAP5-3D (Reactor Excursion and Leak Analysis Program) is a BEs computer simulation software dedicated to the NPP operational transient and accident thermal-hydraulics analysis.[17] Developed at the Idaho National Laboratory (INL) and originally funded by the U.S. Atomic Energy Commission (current U.S. Nuclear Regulatory Commission [NRC]), RELAP5-3D is the state-of-the art tool used for reactor safety analyses, reactor design, simulator training of operators, and nuclear facility licensing. By support from U.S. Department of Energy (DOE), RELAP5-3D was developed in mid-1990s by INL. Notable features of the RELAP5-3D are full three-dimensional hydrodynamics with rectangular, cylindrical, and spherical geometries. As of 2023, RELAP5-3D/Ver. 4.4.2 is the most recent release and the most robust, verified, and validated product of the RELAP5 series.

RELAP5-3D allows for the simulation of the full range of reactor transients and postulated accidents, including:

- Trips and controls
- Component models (pumps, valves, separators, branches, etc.)
- Operational transients
- Startup and shutdown
- Maneuvers (e.g., change in power level, starting/tripping pump)
- Small and large break LOCA

- ATWS
- Loss of offsite power
- Loss of feedwater
- Loss of flow
- Light-water reactors (PWR, BWR, APWR, ABWR, etc.)
- Heavy water reactors (e.g., CANDU reactor)
- Other types of the reactor (e.g., SMR, GenIV).

RELAP5-3D was already used in analyzing ATF loaded system safety in the RISA Pathway activities. The oxidation model of Cr-coated Zr cladding was recently added. The code was also upgraded for the multiphysics uncertainty analysis.

D-2.6.3 FAST

Developed by Pacific Northwest National Laboratory (PNNL), FAST is the fuel performance analysis code to accurately calculate the response of light-water reactor fuel rods in both steady-state conditions as well as rapid transients and severe accident conditions. [18] FAST code is combination of both FRAPCON and FRAPTRAN codes which calculates fuel behavior during steady-state and transient situations separately. The latest version is FAST 1.2 which is compliant with NQA-1. It has capabilities of analyzing ATF such as Cr-coated Zr cladding, FeCrAl cladding, and doped UO₂ rods.

D-2.6.4 RAVEN

Developed by INL, RAVEN is a flexible and multipurpose uncertainty quantification, regression analysis, probabilistic risk assessment, data analysis, and model optimization framework. [17] Depending on the tasks to be accomplished and on the probabilistic characterization of the problem, RAVEN perturbs (e.g., Monte-Carlo, Latin hypercube, reliability surface search) the response of the system under consideration by altering its own parameters. The system is modeled by third party software and is accessible to RAVEN either directly (e.g., software coupling) or indirectly (e.g., via input/output files). The data generated by the sampling process is analyzed using classical statistical and more advanced data mining approaches. RAVEN also manages the parallel dispatching of the software representing the physical model. RAVEN heavily relies on AI algorithms to construct surrogate models of complex physical systems to perform uncertainty quantification, reliability analysis, and parametric studies. RAVEN is the main driver of AI-based core designing optimization platform.

D-2.6.5 MELCOR

MELCOR is a computational code developed by Sandia National Laboratories (SNL) for the NRC, DOE, and the International Cooperative Severe Accident Research Program (CSARP). [11] MELCOR simulates the response of LWRs during severe accidents. Given a set of initiating events and operator actions, MELCOR predicts the plant's response as the accident progresses. MELCOR also includes containment transient analysis capabilities to model thermal-hydraulic phenomena for existing containment designs for PWR and BWR. MELCOR has been proposed in NRC's severe accident analysis guidance and used for source term analysis in the RISA Pathway.

D-2.7 POWER UPRATE DEMONSTRATION

The main goal of the demonstration is to propose a maximum power uprate by using higher enriched (U-235 enrichment up to 10 wt.%, i.e., LEU+) conventional Zr-clad fuel and ATF (FeCrAl and Cr-coated Zr) to confirm its safe operation with minimum system modifications to gain economic benefits. The reactor core will be designed with an AI-based core optimization platform which INL is developing. [19] A generic PWR model will be used, aiming for minimum system change due to the power uprate. Demonstration and safety analysis will be focused on the core designing and system thermal-hydraulic analyses based on limiting DBA scenarios

including multiphysics uncertainty analysis and both deterministic and probabilistic approaches. Fuel performance needs to be analyzed for both steady-state and transients focusing on fission gas behavior and fuel fragmentation, relocation, and dispersal (FFRD). Source term analysis will be also performed. Current regulatory limits will be used as constraints such as power and hot channel peaking factors, boron concentration, departure of nucleate boiling rate (i.e., DNBR), peak cladding temperature, source term, etc. However, new limits and success criteria could be proposed since ATFs have been showing enhanced resiliency in accidental situations. Appendix A shows the timeline of the demonstration for each task, based on the priority.

INL generic 2.5 GWth three-loop Westinghouse PWR model (IGPWR) will be used which is based on Surry NPP. This model has been widely used for safety margin and plant damage assessment in the RISA Pathway to analyze steady-state, DBAs, and beyond design-basis accidents (BDBAs) while using FeCrAl and Cr-coated Zr cladding. [20] Table D-5 summarizes the major design parameters of IGPWR. The model for the demonstration could be changed with any industrial engagement and initiation of the pilot project. However, work scope and plan may remain same.

Table D-5. Major design parameters of IGPWR.

Parameter	Value (SI)	Value (British)
Core power [MWth]	2,546	
Reactor inlet/outlet temperature [°C or °F]	282/319	540/606
Number of fuel assemblies	157	
Rod array	15 × 15	
RCS coolant flow [kg/s or lbm/hr]	12,738	101.6E+8
Nominal RCS pressure [MPa or psia]	15.5	2,250
Number of steam generators	3	
Secondary pressure [MPa or psia]	5.405	785
Secondary side water mass at HFP [kg or lbm]	41,639	91,798
SG volume [m3 or ft3]	166	5,868
Feedwater temperature [°C or °F]	228	443
Main feedwater pump [m3/s or gpm]	2 × 6.513 (at 518m)	2 × 13,800 (at 1,700ft)
Turbine-driven AFW pump [m3/s or gpm]	1 × 0.334 (at 832m)	1 × 700 (at 2,730ft)
Emergency condensate storage tank [m3 or ft3]	416	14,691
Accumulator water volume [m3 or ft3]	3 × 27.61	3 × 975
Accumulator pressure [MPa or psig]	4.14 ~ 4.59	600 ~ 665
High head safety injection [m3/s or gpm]	3 × 0.0708 (at 1,767m)	3 × 150 (at 5,800ft)
Low head safety injection [m3/s or gpm]	2 × 1,416 (at 68.6m)	2 × 3,000 (at 225ft)
Containment volume [m3 or ft3]	50,970	1,800,000
Containment design pressure [MPa or psig]	0.31	45
Containment operating pressure [MPa or psig]	0.062 ~ 0.071	9 ~ 10.3

It is noted that the Surry NPP has been already power uprated from 2,546 to 2,587 MWth, which is approximately 1.6%, by implementing a new feedwater system to reduce feedwater flow measurement uncertainties. As a result, overall power level measurement uncertainty is about 0.35% at reactor power[§]. [21] The IGPWR model will be first upgraded to meet current power uprate.

[§] Surry NPP was initially licensed for 2,441 MWth and power uprate to 2,546 MWth in 1995. Second power uprate was approved in 2010 for 2,587 MWth.

D-2.8 AI-Based Core Design

Core design will be started with conventional manual method and proceed with AI-based methodology which the RISA Pathway is developing. [19] The AI-based core design optimization platform is an integrated, comprehensive platform offering an all-in-one solution for reactor core reload evaluations with a special focus on optimization of core design considering feedback from system safety analysis and fuel performance. RAVEN is the main platform driver which gives unlimited flexibility in using modern AI techniques such as Genetic algorithm (GA). This GA method is a proven technology for fuel reload optimization purposes.

RAVEN’s capability is not just limited to optimization. It can also provide input decks to other physical codes and perform post-processing of simulation results. This extensibility of RAVEN facilitates coupling with other physical codes for core design, fuel performance, and systems analysis, which can lead to a unified framework that considers physical phenomena. Hence, using RAVEN as a controller of the GA method allows a “tool-independent” one-stop plant reload optimization platform with easy access for users.

The optimization platform can set multiple objectives and constraints such as fuel cycle length (e.g., an extension from 18 to 24 months), fuel enrichment, burnable poisons, core design limits (e.g., peaking factors and boron concentration), and safety parameters (e.g., peak cladding temperature and DNBR). To do this, the RISA Pathway GA-based optimization platform uses the following individual computational tools coupled with RAVEN to provide safety feedback during core designing. Figure D-3 gives a snapshot of the optimization platform.

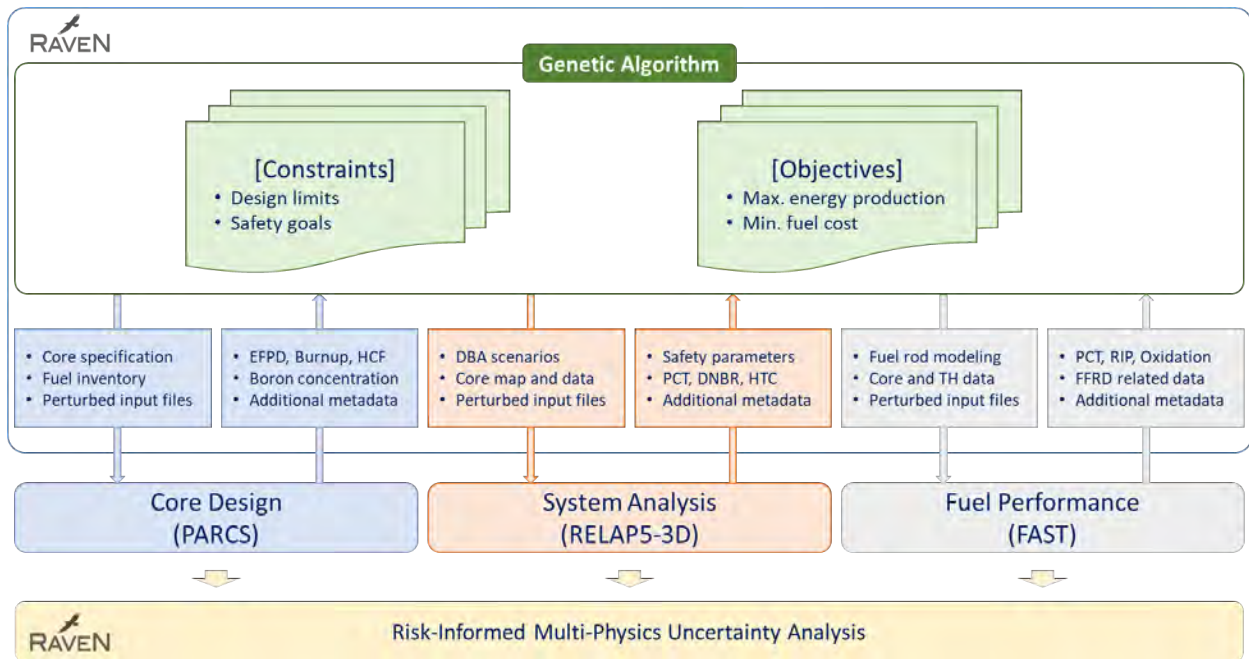

Figure D-3. High-level flow chart of LWR-developed fuel reload optimization platform.

The uncertainties can be quantified by RAVEN during the multiphysics simulation. However, the propagation of uncertainties across the different physics calculations may increase complexity of the algorithm, computational burden, and applicability in practical use. In some circumstances it could be more convenient and efficient to bound values from one discipline before proceeding to the next step in the simulation stream, especially when the potential loss in analytical margin is small compared to the added complexity.

Note that for analyses directly supporting a plant licensing basis, additional or potentially different tools may be needed. For example, the reactor subchannel analysis is typically modeled by another thermal-hydraulics code which solves the details of the heat transfer within the fuel assembly. This is necessary for the evaluation

of critical heat flux or DNBR which has associated limits tracked in the safety analyses. The subchannel code is typically validated with fuel-product-specific data, often from the fuel vendors' proprietary data.

D-2.9 Safety Analysis

Figure D-4 is the nodalization of IGPWR for RELAP5-3D analysis. [20] The model has a total of 215 hydraulic volumes connected with 257 junctions, coupled with 240 heat structures to simulate heat generation and loss. One or three-dimensional radial cores are available. The reactor core is linked with three identical steam generator loops.

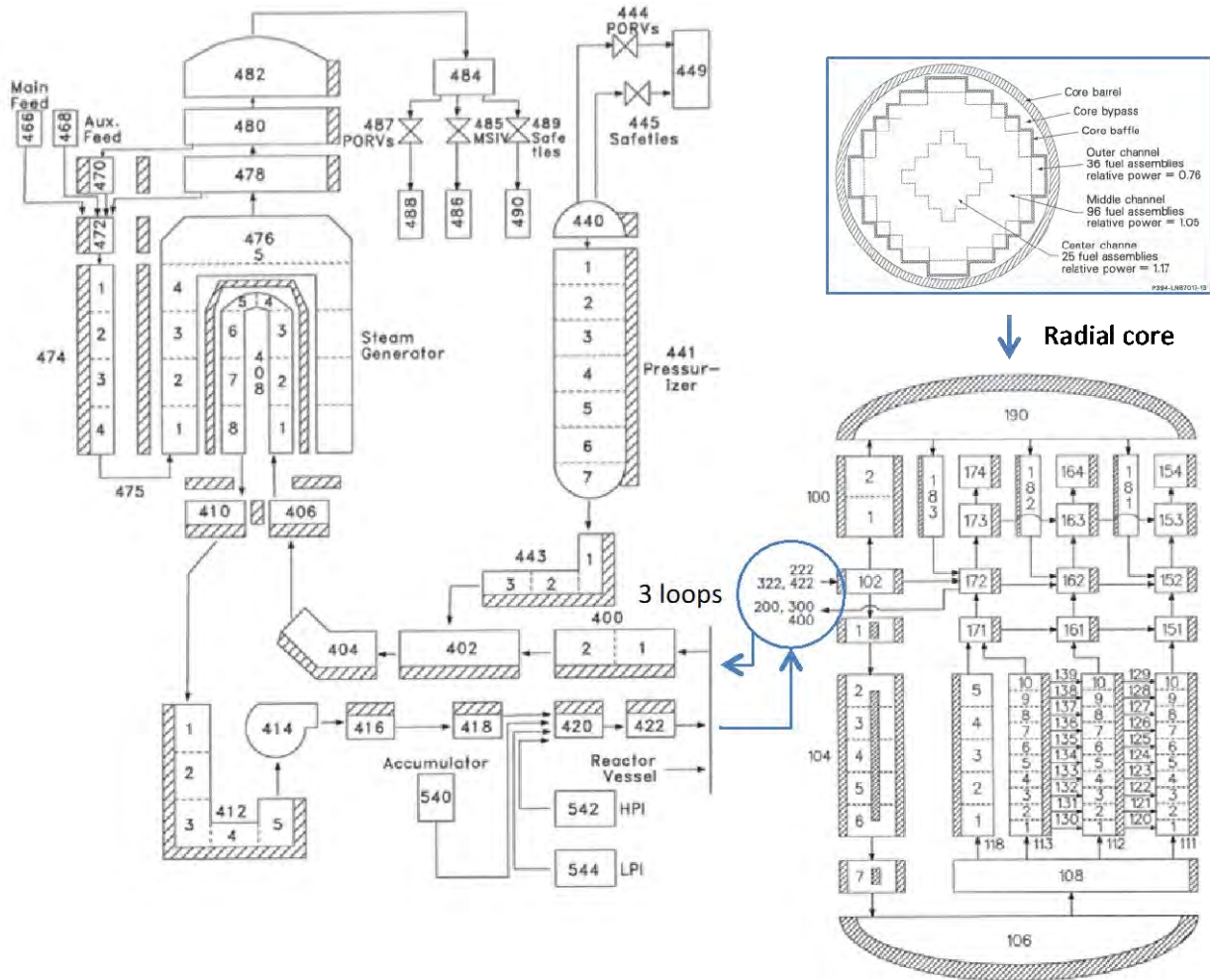

Figure D-4. RELAP5-3D nodalization for IGPWR.

This model was originally developed for analyzing reactor cooling systems during a station blackout event. The following components are modeled:

- Reactor pressure vessel
- Three reactor coolant loops, including the main coolant pumps and the steam generators
- Pressurizer, and its main valves (PORV and SV)^h
- Connections for the emergency core cooling system and auxiliary feedwater system

^h. PORV: Pressure operated relief valve, SV: Safety valve.

- Secondary part of the SGs up to the SG outlet, including the SG main valves (PORV and SV)
- Main feedwater
- ECCS including high- and low-pressure safety injection (H/LPSI) systems and accumulators.

For the operational and accidental safety analyses, both Zr and ATF cladding fuel cases will be assessed. Most of scenarios are already developed in RELAP5-3D input and need minor updates, or otherwise need to be developed. The scenarios are limiting accident cases which represent major safety concerns. Each scenario has multiple scenarios with various combinations of safety feature activations. Point and nodal kinetics need to be developed by PARCS, SCALE, and POLARIS computational tools considering the 15×15 fuel assembly design with ATF. Different fuel assembly designs (e.g., 17×17 or 21×21) will also be tested.

Each AOO, DBA, and BDBA scenario has different cases based on the different safety features, reactivation time, or success criteria. Additional cases might need to be developed in due course.

D-2.9.1 Power Uprate with ZR Cladding Fuel

The current RELAP5-3D steady-state model will be upgraded taking into account the existing power uprate using conventional Zr cladding fuel. Major design parameters in Table D-5 will also be revised based on the new power rate of 2,587 MWth [21]. Steady-state in normal operation will be simulated and followed by selective DBA analyses, which will be assessed including LBLOCA. The results will be compared with the existing Surry NPP FSAR to verify the power uprate model.

D-2.9.2 Power Uprate with ATF Cladding Fuel: Steady-State Normal Operation

ATF loaded core will be designed with AI-based method and the core thermal power will be imposed to the RELAP5-3D input. The goal of this analysis is to decide the reachable maximum amount of power uprate with given higher enriched ATFs. The requirements given in Table D-4 and plant operational design parameters shown in Table D-5 will be verified to confirm system reliability and performance.

D-2.9.3 Power Uprate with ATF Cladding Fuel: Anticipated Operational Occurrences

The following AOO scenarios will be analyzed:

- FW system malfunctions that result in a decrease in FW temperature (model upgrade neededⁱ)
- Turbine trip (model upgrade needed)
- Loss of nonemergency AC power to the station auxiliaries (model development needed)
- CVCS malfunction that results in a decrease in the boron concentration in the reactor coolant (model development needed)
- Inadvertent operation of the ECCS during power operation (model development needed).

D-2.9.4 Power Uprate with ATF Cladding Fuel: Transients and Design Basis Accidents

Following transient and DBA scenarios will be analyzed:

- LOCAs resulting from a spectrum of postulated piping breaks within the reactor coolant primary boundary (i.e., SBLOCA) (model upgrade needed)
- Steam system piping failure (i.e., MSLB) (model upgrade needed)
- RCP shaft seizure (e.g., locked rotor) (model upgrade needed)

ⁱ Upgrade for power uprate with ATF.

- Spectrum of RCCA ejection accidents (i.e., RIA) (model development needed)
- SGTR (model upgrade needed)
- LOCAs resulting from the spectrum of postulated piping breaks within the large size RCPB (i.e., LBLOCA) (model upgrade needed).

D-2.9.5 Power Uprate with ATF Cladding Fuel: Beyond Design Basis Accident

The severe accident scenario will be based on the U.S. NRC's State-of-the-Art Reactor Consequence Analysis (SOARCA) project which assessed severe accident progression and offsite consequences in response to security-related events.[15] This approach uses a BEs method and has already been demonstrated in RISA Pathway. [20]

One case of BDBA will be demonstrated:

- Long term station blackout (LTSBO) (model upgrade needed).

D-2.10 Fuel Performance Analysis

Fuel performance analysis is a mandatory step to confirm fuel integrity and safety during normal operation and to ensure minimum damage during postulated accidents. The FAST code can be employed for both steady-state and transient analyses and incorporates models accounting for the different and interrelated phenomena occurring in the fuel rod. FAST code has been showing good results for both FeCrAl and Cr-coated Zr. [22] The modeling of fission gas behavior is a crucial aspect of nuclear fuel analysis in view of the related effects on the thermo-mechanical performance of the fuel rod, which can be particularly significant during transients. FFRD behavior of ATF is especially still under investigation and the modeling and simulation approach is limited. This research will focus on demonstrating code capabilities and identifying gaps in fuel performance analysis in the case of a power uprate.

D-2.11 Source Term Analysis

In a postulated accident case, the radioactive reactor coolant would be released to the containment through the break or leak in the RCS. As such an accident progresses, radioactivity in the fuel gap would be released to the coolant through failed cladding, followed by melting of the fuel and core materials. In this early in-vessel release phase, a significant amount of the noble gases and fission products will be released into the reactor containment. The molten core (i.e., corium) will penetrate the reactor vessel bottom head during the ex-vessel release phase which generates large quantities of non-radioactive aerosols from molten core-concrete interactions. On a longer timeframe, there will be late in-vessel release of volatile nuclides which were deposited in the RCS.

Table D-6 and Table D-7 show list of the source term radionuclide groups to be considered during DBA analyses and release limits to the containment during the PWR postulated accidents, respectively. [11] The values of source term are the fractions of initial core fission product inventory. In the case of long-term cooling the gap release fraction will be up to 3%. Since LEU+ ATF power uprate will increase enrichment of the fissile materials, source term will be also increased. For this reason, thorough source term analysis will be very important.

For the fission product release, which is major part of the source term, two different phenomena are important. The first is called "high-pressure melt ejection." If the RCS was at high pressure when vessel bottom head failed, the molten core will be ejected to the containment with high velocity. This will lead to a rapid increase of in-containment temperature as well as aerosol type source terms. Another phenomenon is molten core debris released as airborne fission product from the large-scale steam explosion as a result of interaction between molten core and water. Small-sized steam explosions will likely occur but will be negligible in increasing source term; however, a large-scale explosion will ease release of molten core debris within the vapor and water droplets.

Table D-6. Radionuclide groups in source term.

Group	Element
Noble gases	Xe, Kr
Halogens	I, Br
Alkali metals	Cs, Rb
Tellurium group	Te, Sb, Es
Barium, Strontium	Ba, Sr
Noble metals	Ru, Rh, Pd, Mo, Tc, Co
Lanthanides	La, Zr, Nd, Eu, Nb, Pm, Pr, Sm, Y, Cm, Am
Cerium group	Ce, Pu, Np

Table D-7. Source term release limitation to the containment in PWR DBAs.

	Gap release	In-vessel	Ex-vessel	Late in-vessel
Duration (hours)	0.5	1.3	2.0	10.0
Noble gases	0.05	0.95	0	0
Halogens	0.05	0.35	0.25	0.1
Alkali metals	0.05	0.25	0.35	0.1
Tellurium group	0	0.05	0.25	0.005
Barium, Strontium	0	0.02	0.1	0
Noble metals	0	0.0025	0.0025	0
Lanthanides	0	0.0002	0.005	0
Cerium group	0	0.0005	0.005	0

The amount of source term in each phase during the severe accident was first calculated by MELCOR code for 40 to 62 GWD/MTU burnup PWR [23] and BWR. [24] In these studies, various postulated accidents were considered to evaluate source term release time and amounts. The result of these studies became reference data to set the NRC guide and DG-1389 (1.183 rev 1). [25]

The source term from the Fukushima-type BWR with FeCrAl cladding fuel was evaluated under DBA and BDBA scenarios. [15] In DBAs, the ATF benefits were less oxidation and higher heat capacity that significantly reduced peak cladding temperatures (PCT). Either the ECCS injection was delayed or not even activated. However, in the case of the BDBA scenarios, the higher melting point and less oxidation will not preclude a severe accident if core cooling cannot be restored.

In this research the amount of source term and environmental impact and consequences will be analyzed by using MELCOR. Particle tracking with size distribution and dispersal behavior will also be assessed.

D-3. SUMMARY

A scoping study was conducted for physics-based aspects of a power uprate by using higher enriched (e.g., up to 10wt.%) fuel with conventional Zr or ATF, focusing on PWRs. An AI-based fuel assembly and core designing optimization method is proposed to find maximum benefit from power uprate considering design and safety limitations. A proposed optimized reactor core will be used as reactor data for NOOs and selective AOOs, and DBA simulations will be used to confirm if a plant is operating with reliability and can retain adequate safety margins during transients. Table D-4 shows the requirements for NOO. For transients, current regulatory limits such as power and hot channel peaking factors, boron concentration, departure of nucleate boiling rate (< 1.2), peak cladding temperature ($< 2200^{\circ}\text{F}$), and source terms will be applied. However, new limits and success criteria could be proposed since ATFs have shown enhanced resiliency in accidental situations.

D-4. TIMELINE OF THE POWER UPRATE DEMONSTRATION

Milestone	Scope	Task
Year 1	Core design	<ul style="list-style-type: none"> • Develop LEU+ ATF loaded core in conventional method (FeCrAl and Cr-Zr) for 15 × 15 fuel assembly • Core design parameters will be same to conventional Zr fuel
	Safety analysis	<ul style="list-style-type: none"> • Improve IGPWR model for existing power uprate and normal operation and LBLOCA analysis • Demonstrate IGPWR model for LEU+ ATF loaded power uprate with normal operation and LBLOCA • Development of IGPWR model for RIA scenario and demonstration
	Fuel performance	<ul style="list-style-type: none"> • Steady-state and LBLOCA analysis during power uprate
Year 2	Core design	<ul style="list-style-type: none"> • Improve core design with AI-based optimization methodology with safety analysis and fuel performance feedback • Improve fuel assembly design (15 × 15, 17 × 17, and 21 × 21) • Propose equilibrium core reloading pattern for transition of the fuel cycle
	Safety analysis	<ul style="list-style-type: none"> • Analyses on existing AOO and DBA scenarios <ul style="list-style-type: none"> - LOFW, turbine trip, SBLOCA, MSLB, RCP failure, and SGTR • Development of additional AOO and DBA scenarios <ul style="list-style-type: none"> - Loss of nonemergency power, CVCS malfunction, and ECCS failure • Improve RIA scenario by applying fuel performance analysis and feedback to AI-based core design
	Fuel performance	<ul style="list-style-type: none"> • RIA analysis and provide feedback to safety analysis
	Source term	<ul style="list-style-type: none"> • Source term inventory and release scenario analysis during LBLOCA
Year 3	Core design	<ul style="list-style-type: none"> • Improve existing core design as needed • Propose new core design parameters for LEU+ ATF power uprate
	Safety analysis	<ul style="list-style-type: none"> • Application of multiphysics risk-informed uncertainty analysis methodology to LBLOCA and RIA • Propose new success criteria for LEU+ ATF power uprate • Analysis in severe accident scenario: LTSBO
	Fuel performance	<ul style="list-style-type: none"> • FFRD analysis in RIA and LBLOCA to improve source term analysis
	Source term	<ul style="list-style-type: none"> • Environmental consequence analysis during LBLOCA

D-5. TECHNICAL GAPS IN COMPUTATIONAL TOOLS AND MODELING

Area	Description	Proposed Solutions / Remarks
RELAP5-3D	Fuel cladding failure model is too conservative. The model predicts early cladding failure because fuel-cladding gap and fuel rod plenum model is omitted.	This is known issue and RELAP5-3D manual proposes to use fuel performance tool for accurate result once fuel cladding has failed. Updating RELAP5-3D is possible to reduce over-conservatism, but still less accurate than dedicated fuel performance tool.
RELAP5-3D	Existing IGPWR model is based on the Surry NPP which is based on the 1st power uprate (2,546 MWth). For realistic demonstration, 2nd power uprate (2,587 MWth) should be applied to current IGPWR model.	Included in the work scope. This task is with highest priority since updated IGPWR model will be the base of normal operation and transient simulation for safety analysis.
RELAP5-3D	Following accident scenarios with IGPWR need to be updated for 2nd power uprate (2,587 MWth). <ul style="list-style-type: none"> • FW system malfunctions that result in a decrease in FW temperature • Turbine trip • LOCAs resulting from a spectrum of postulated piping breaks within the reactor coolant primary boundary (i.e., SBLOCA) • Steam system piping failure (i.e., MSLB) • RCP shaft seizure (e.g., locked rotor) • SGTR • LOCAs resulting from the spectrum of postulated piping breaks within the large size RCPB (i.e., LBLOCA) • Long term station blackout (LTSBO) 	Included in the work scope.
RELAP5-3D	Following accident scenarios with IGPWR need to be developed for 2nd power uprate (2,587 MWth). <ul style="list-style-type: none"> • Loss of nonemergency AC power to the station auxiliaries • CVCS malfunction that results in a decrease in the boron concentration in the reactor coolant • Inadvertent operation of the ECCS during power operation • Spectrum of RCCA ejection accidents (i.e., RIA) 	Included in the work scope.
Fuel performance	Modeling and simulation of FFRD for ATF is still under development. Especially for Cr-coated Zr, the Hoop stress curve varies non-linearly to the thickness of Cr coating.	This issue is well known. However, development of the capability is beyond the LWRS Program. Zr cladding model could be used with uncertainties. Further investigation is necessary. No issue in FeCrAl cladding.

D-6. APPENDIX D REFERENCES

- [1] IAEA. 2011. “Power Uprate in Nuclear Power Plants: Guidelines and Experience.” International Atomic Energy Agency Nuclear Energy Series, NP-T-3.9. Vienna, Austria. https://www-pub.iaea.org/MTCD/Publications/PDF/Pub1484_web.pdf.
- [2] U.S. NRC. 2021. “Approved Applications for Power Uprates.” United States Nuclear Regulatory Commission. <https://www.nrc.gov/reactors/operating/licensing/power-uprates/status-power-apps/approved-applications.html>.
- [3] Shirvan, K. and Csontos, A. 2022. “Achieving Sizable Power-Uprate for Existing Fleet Through LEU+ and ATF.” OSF Preprints. <https://doi.org/10.31219/osf.io/ykxh4>.
- [4] IAEA. 2004. “Implication of Power Uprates on Safety Margins of Nuclear Power Plants.” International Atomic Energy Agency, IAEA-TECDOC-1418. OECD/NEA Technical Meeting, Vienna, Austria: October 13-15, 2003. https://www-pub.iaea.org/MTCD/Publications/PDF/te_1418_web.pdf.
- [5] Sweet, R. T., Bell, S. B., Kane, K. A., Capps, N. A. 2021. “Fuel Performance Analysis of Chromium-Coated Cladding under Burst Conditions.” *Nuclear Technology Research and Development*. Oak Ridge National Laboratory, ORNL/SPR-2021/2284. <https://info.ornl.gov/sites/publications/Files/Pub168383.pdf>.
- [6] Rebak, R. B., et al. 2015. “Assessment of advanced steels as accident tolerant fuel cladding for commercial light water reactors.” *17th International Conference on Environmental Degradation of Materials in Nuclear Power Systems – Water Reactors*, August 9-13, Ottawa, Ontario, Canada.
- [7] Stuart, S. 2013. “Nuclear Power Generation: Modern Power Station Practice.” *2nd Edition*. Elsevier.
- [8] Zhang, H, et al. 2019. “Fuel rod burst potential evaluation under LOCA conditions for an existing plant with extended burnup exceeding the current limit by 20%.” *Light Water Reactor Sustainability Program*. Idaho National Laboratory, INL/EXT-19-55888. https://lwrs.inl.gov/RiskInformed%20Safety%20Margin%20Characterization/Fuel_Rod_Burst_Potential_Evaluation_under_LOCA_Conditions_for_an_Existing_Plant.pdf.
- [9] Skutch, J., Slagle, W. H., and Sung, Y. 1997. “TVA: Watts Bar Unit 1 Cycle 2 Reload Safety Evaluation.” Westinghouse Electric Corporation, CAC-97-278. <https://www.nrc.gov/docs/ML0734/ML073460287.pdf>.
- [10] George, N. M., Terrani, K. A., and Powers., J. J. 2013. “Neutronic analysis of candidate accident-tolerant iron alloy cladding concepts.” Oak Ridge National Laboratory, ORNL/TM-2013-121. <https://info.ornl.gov/sites/publications/files/Pub41927.pdf>.
- [11] Choi, Y-J., et al. 2022. “Safety Analysis for Accident-Tolerant Fuels with Increased Enrichment and Extended Burnup.” Idaho National Laboratory, INL/RPT-22-68581, rev. 1.
- [12] U.S. NRC. 2017. “Standard Review Plan for the Review of Safety Analysis Reports for Nuclear Power Plants: LWR Edition.” U.S. Nuclear Regulatory Commission, NUREG-0800. <https://www.nrc.gov/reading-rm/doc-collections/nuregs/staff/sr0800/index.html>.
- [13] Parisi, C., Choi, Y-J. 2020. “Risk-Informed Multi-Physics Best-Estimate Plus Uncertainties (BEPU) Application Development of RELAP5-3D Perturbation Model.” Idaho National Laboratory, INL/EXT-20-59594, rev. 0. <https://doi.org/10.2172/1968433>.
- [14] IAEA. 2008. “Best Estimate Safety Analysis for Nuclear Power Plants: Uncertainty Evaluation.” *Safety Report Series*, International Atomic Energy Agency, vol 52. Vienna, Austria. https://www-pub.iaea.org/MTCD/Publications/PDF/Pub1306_web.pdf.
- [15] Chang, R., et al. 2012. “State-of-the-Art Reactor Consequence Analyses (SOARCA) Report.” U.S. Nuclear Regulatory Commission, NUREG-1935. <https://www.nrc.gov/docs/ML1233/ML12332A057.pdf>.
- [16] Rearden, B. T. and Anderson, J. M. 2018. “SCALE Code System.” Oak Ridge National Laboratory, ORNL/TM-2005/39, rev. 6.2.3. <https://doi.org/10.2172/1426571>.

- [17] Choi, Y-J. 2019. "Assessment of verification and validation status - RELAP5-3D and RAVEN." Idaho National Laboratory, INL/EXT-19-56151, rev. 1. https://lwrs.inl.gov/RiskInformed%20Safety%20Margin%20Characterization/Assessment_of_VandV_status_REPAP5.pdf.
- [18] Geelhood, K. J., et al. 2022. "FAST-1.1: A Computer Code for Thermal-Mechanical Nuclear Fuel Analysis under Steady-state and Transients." Pacific Northwest National Laboratory, PNNL-32770.
- [19] Choi, Y-J., et al. 2022. "Development and Demonstration of a Risk-Informed Approach to the Regulatory Required Fuel Reload Safety Analysis." Idaho National Laboratory, INL/RPT-22-68628, rev. 0. <https://doi.org/10.2172/1885790>.
- [20] Zhegang, M., et al. 2018. "Plant-Level Scenario-Based Risk Analysis for Enhanced Resilient PWR – SBO and LBLOCA." Idaho National Laboratory, INL/EXT-18-51436. <https://doi.org/10.2172/1495192>.
- [21] U.S. NRC. 2010. "Surry Power Station Unit 1 & 2 - Amendment to Renewed Facility Operating License." U.S. Nuclear Regulatory Commission, US NRC ML101750002, Docket Nos. 50-280 and 50-280. <https://www.nrc.gov/docs/ML1017/ML101750002.pdf>.
- [22] Aragón, P., Feria, F., and Herranz, L. E. 2022. "Modelling FeCrAl cladding thermo-mechanical performance. Part I: Steady-state conditions." *Progress in Nuclear Energy*, 153, (Nov): 104417. <https://doi.org/10.1016/j.pnucene.2022.104417>.
- [23] Ashbaugh, S. G. et al. 2010. "Accident Source Terms for Pressurized Water Reactors with High-Burnup Cores Calculated Using MELCOR 1.8.5." Sandia National Laboratory, SAND2008-6664. <https://www.osti.gov/servlets/purl/984120>.
- [24] Salay, M. et al. "Accident Source Terms for Light-Water Nuclear Power Plants Using High-Burnup or MOX Fuel." Sandia National Laboratory, SAND2011-0128. <https://doi.org/10.2172/1010412>.
- [25] U.S. NRC. 2022. "Alternative Radiological Source Terms for Evaluating Design Basis Accidents at Nuclear Power Reactors." U.S. Nuclear Regulatory Commission, DG-1389, 87 FR 23891: 23891-23892. <https://www.federalregister.gov/documents/2022/04/21/2022-08519/alternative-radiological-source-terms-for-evaluating-design-basis-accidents-at-nuclear-power>. <https://www.nrc.gov/docs/ML2120/ML21204A065.pdf>.